

Max. 1220 m³/h
S-Force

DC axial fans

220 x 200 x 51 mm



- **Material:** Housing: Die-cast aluminum
Impeller: GRP¹⁾ (PA)
- **Direction of air flow:** Exhaust over struts
- **Direction of rotation:** Counterclockwise, looking towards rotor
- **Connection:** Via single wires AWG 18, 20 or AWG 22, TR 64, speed signal and control input AWG 22
- **Highlights:** Highly efficient and smoothly operating 3-phase fan drive
Housing with grounding lug for screw M4 x 8 (Torx)
- **Weight:** 1000 g
- **Possible special versions:** (See chapter DC fans - specials)
 - Speed signal
 - Go / NoGo alarm
 - Alarm with speed limit
 - External temperature sensor
 - Internal temperature sensor
 - PWM control input
 - Analog control input
 - Multi-option control input
 - Moisture protection
 - Salt spray protection
 - Degree of protection: IP 54 / IP 68

1) Fiberglass-reinforced plastic

Series 2200 FTD
VWS0184FULDS
VWS0184FULCS

Nominal data

Type	Air flow		Nominal voltage	Voltage range	Sound pressure level	Sound power level	Sintec sleeve bearings Ball bearings	Power consumption*	Nominal speed	Temperature range	Service life L ₁₀ (40 °C) ebm-papst standard	Service life L ₁₀ (T _{max}) ebm-papst standard	Life expectancy L ₁₀ IPC (40 °C) see page 15	Curve
	m ³ /h	cfm												
2214 F/2 TDHO	790	465	24	16...30	62	7.1	■	35	4250	-20...+75	90 000 / 42 500	152 500	①	
2214 F/2 TDHHO	940	553	24	16...36	66	7.4	■	48	5000	-20...+70	85 000 / 42 500	142 500	②	
2218 F/2 TDHO	790	465	48	36...57	62	7.1	■	35	4250	-20...+75	90 000 / 42 500	152 500	①	
2218 F/2 TDHHO	940	553	48	36...72	66	7.4	■	48	5000	-20...+70	85 000 / 42 500	142 500	②	
2218 F/2 TDH4P	1220	718	48	36...72	72	8.2	■	103	6500	-20...+65	70 000 / 40 000	117 500	③	

Subject to change

Speed control range from 1000 rpm⁻¹ up to maximum nominal speed.

Standstill at 0 % PWM, Type O: standstill if control wire is interrupted; Type P: maximum speed if control wire is interrupted.

* Power consumption at free air flow. These values can be significantly higher in the operating point.

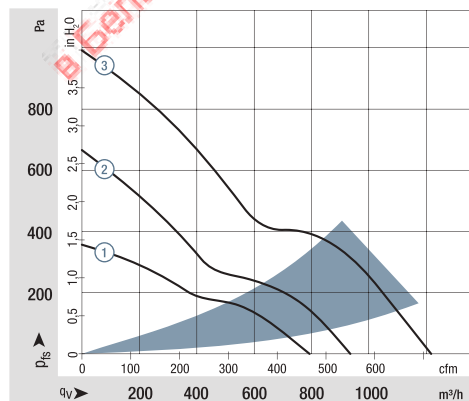

Air performance measured according to: ISO 5801.
Installation category A, without contact protection.
Noise: Total sound power level L_{WA} ISO 10302 measured on a hemisphere with a radius of 2 m.
Sound pressure level L_{pA} measured at 1 m distance from fan axis.

The values given are applicable only under the specified measuring conditions and may differ depending on the installation conditions.

In the event of deviation from the standard configuration, the parameters must be checked after installation!

For detailed information see

<http://www.ebmpapst.com/general-conditions>

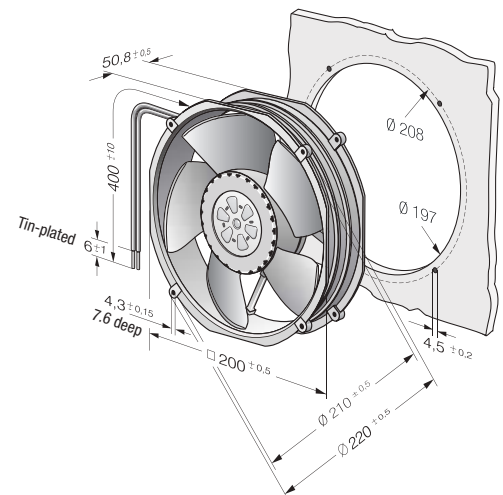

max. 1000 m³/h

DC axial fans

□ 225 x 80 mm



- **Material:** Fan housing: Die-cast aluminum
Impeller: GRP¹⁾
 - **Direction of air flow:** Exhaust over struts
 - **Direction of rotation:** Counterclockwise, looking towards rotor
 - **Connection:** Via terminal strip
 - **Highlights:** 3-phase fan drive with very smooth operation
Electrical commutation completely integrated
 - **Weight:** 2.1 kg
- **Possible special versions:** (See chapter DC fans - specials)
 - Speed signal
 - Go / NoGo alarm
 - Alarm with speed limit
 - External temperature sensor
 - Internal temperature sensor
 - PWM control input
 - Analog control input
 - Multi-option control input
 - Moisture protection
 - Degree of protection: IP 54

1) Fiberglass-reinforced plastic

Series 2200 TD
VWS0196XULCS

Nominal data

Type	Air flow		Nominal voltage	Voltage range	Sound pressure level	Sound power level	Sinter sleeve bearings Ball bearings	Power consumption	Nominal speed	Temperature range	Service life L ₁₀ (40 °C) ebm-papst standard	Service life L ₁₀ (T max) ebm-papst standard	Life expectancy L ₁₀ (IPC (40 °C) see page 15	Curve
	m ³ /h	cfm												
2214/2 TDO	1000	588	24	16...30	59	6.8	■	50	3 000	-20...+60	80 000 / 50 000	135 000	①	
2218/2 TDO	1000	588	48	36...57	59	6.8	■	50	3 000	-20...+60	80 000 / 50 000	135 000	①	

Subject to change

* Power consumption at free air flow. These values can be significantly higher in the operating point.

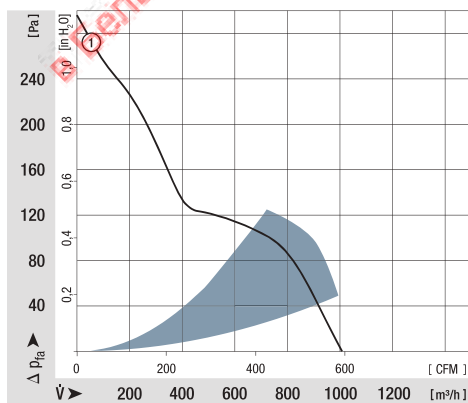

Air performance measured according to: ISO 5801.
Installation category A, without contact protection.
Noise: Total sound power level L_{WA} ISO 10302 measured on a hemisphere with a radius of 2 m.
Sound pressure level L_{PA} measured at 1 m distance from fan axis.
The values given are applicable only under the specified measuring conditions and may differ depending on the installation conditions.
In the event of deviation from the standard configuration, the parameters must be checked after installation!
For detailed information see <http://www.ebmpapst.com/general-conditions>

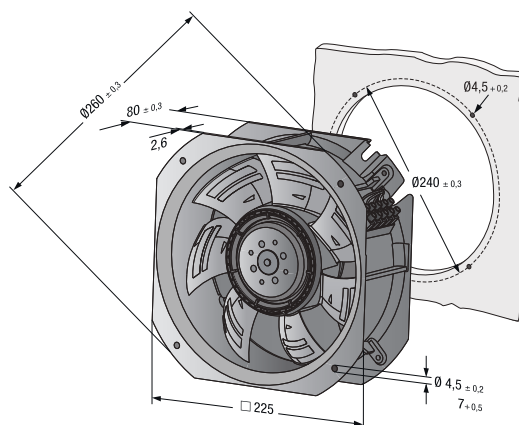

Max. 1245 m³/h

DC diagonal module

□ 225 x 80 mm



- **Material:** Housing and support bracket: Fiberglass-reinforced plastic (PA6)
Impeller: Fiberglass-reinforced plastic (PA6)
Rotor: Painted black
- **Number of blades:** 7
- **Direction of air flow:** "V"
- **Direction of rotation:** Clockwise, looking towards rotor
- **Degree of protection:** Ⓐ Ⓒ IP 44, Ⓑ Ⓓ IP 20, depending on installation and position
- **Insulation class:** "B"
- **Installation position:** Any
- **Condensation drainage holes:** Ⓐ Ⓒ none, Ⓑ Ⓓ seen on rotor
- **Mode of operation:** Continuous operation (S1)
- **Bearings:** Maintenance-free ball bearings

VJH0200XUNCS

Nominal data

Type	Motor	Curve	Nominal voltage		Air flow	Nominal speed	Power consumption	Input current	Sound power level	Admissible amb. temp.	Weight	Technical features and connection diagram
			VDC	VDC								
K1G 200-AD65-04	M1G 074-BF	Ⓐ	24	16...28	1020	3 400	95	4.7	76	-25...+60	1.8	p. 277 / J5)
K1G 200-AD31-02	M1G 074-BF	Ⓑ	24	16...28	1045	3 500	110	5.4	77	-25...+70	1.7	p. 277 / J5)
K1G 200-AD49-04	M1G 074-BF	Ⓒ	48	36...57	1095	3 650	120	3.4	77	-25...+60	1.8	p. 277 / J5)
K1G 200-AD37-02	M1G 074-BF	Ⓓ	48	36...57	1245	4 140	183	5.6	81	-25...+70	1.7	p. 277 / J5)

Subject to change

Curves:

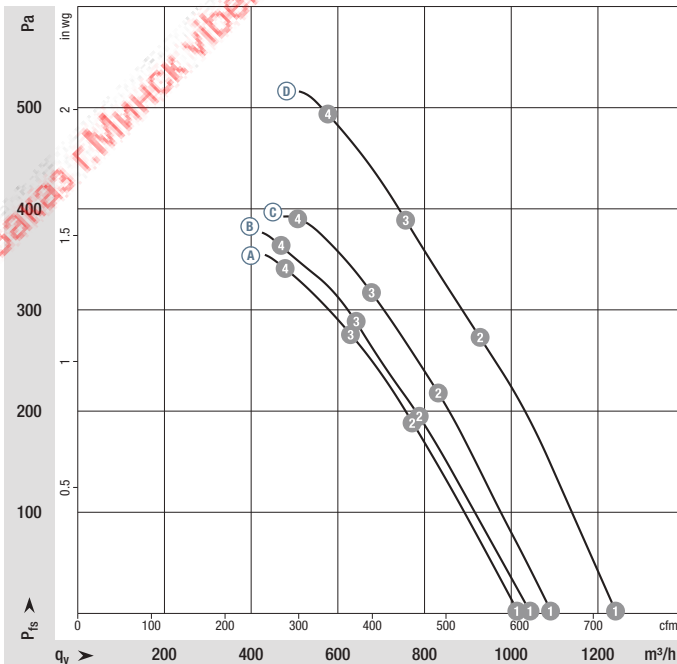

	n	P _{ed}	I	L _{WA}
	rpm ⁻¹	W	A	dB(A)
Ⓐ 1	3400	95	4.70	76
Ⓐ 2	3410	116	5.61	74
Ⓐ 3	3410	119	5.75	74
Ⓐ 4	3410	117	5.62	76
Ⓑ 1	3500	110	5.40	77
Ⓑ 2	3510	127	6.24	75
Ⓑ 3	3510	129	6.31	75
Ⓑ 4	3510	125	6.15	76
Ⓒ 1	3650	120	3.40	77
Ⓒ 2	3645	141	3.90	75
Ⓒ 3	3640	145	3.99	76
Ⓒ 4	3645	141	3.88	80
Ⓓ 1	4140	183	5.60	81
Ⓓ 2	4080	212	6.46	79
Ⓓ 3	4060	213	6.52	79
Ⓓ 4	4105	211	6.43	80

Air performance measured according to: ISO 5801, Installation category A, without contact protection. Suction-side noise levels: L_{WA} according to ISO 13347, L_{pA} measured at 1 m distance from fan axis. The values given are applicable only under the specified measuring conditions and may differ depending on the installation conditions. In the event of deviation from the standard configuration, the parameters must be checked after installation! For detailed information see http://www.ebmpapst.com/general_conditions

- **Technical features:** See connection diagram p. 277
- **EMC:** Immunity to interference according to EN 61000-6-2 (industrial environment)
Interference emission according to EN 55022 (Class B)
- **Cable exit:** Lateral
- **Protection class:** I (with customer connection to grounding conductor)
- **Conformity with standard(s):** EN 60335-1
- **Approvals**
 - Ⓐ Ⓒ UL 1004-1, CSA C22.2 no. 77
 - Ⓑ Ⓓ EAC, UL 1004-1, CSA C22.2 no. 77

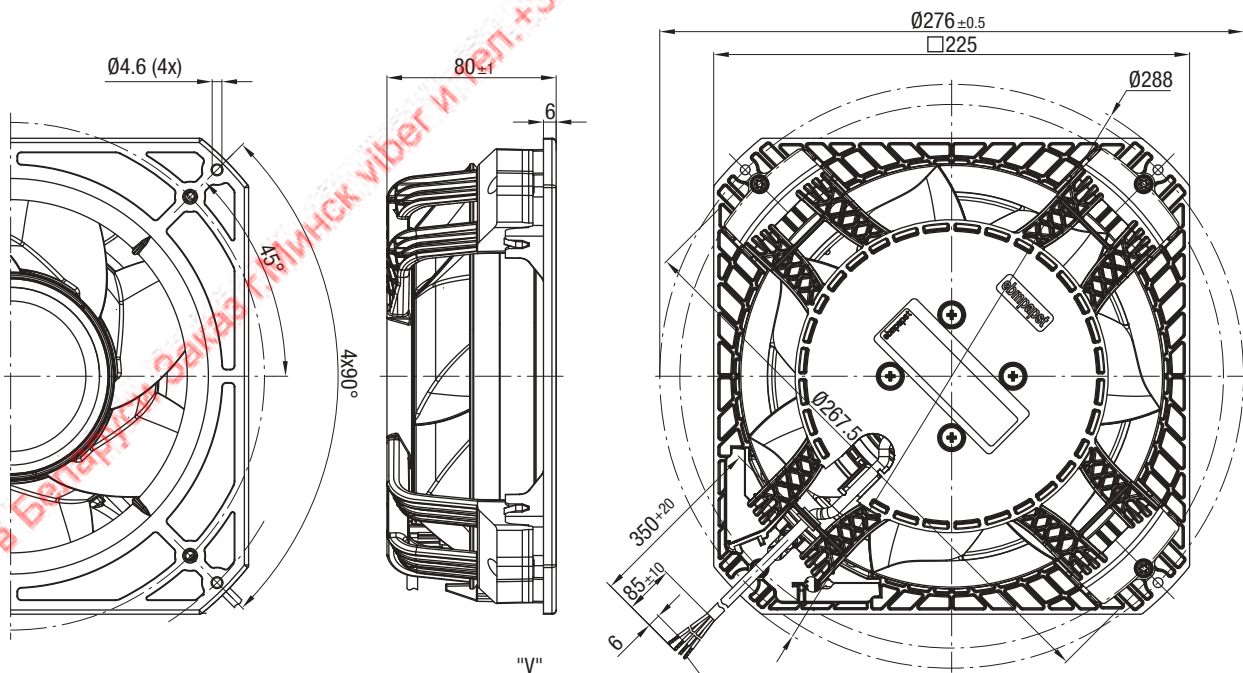

Cable assignment:
 Red = UN
 Yellow = 0-10 VDC
 White = tach output
 Blue = GND

AWG 20 cable,
4x crimped splices

Max. 1650 m³/h

DC diagonal module

□ 225 x 89 mm



- **Material:** Housing and support bracket: Plastic (PA)
Impeller: Plastic (PA)
Rotor: Painted black
- **Number of blades:** 7
- **Direction of air flow:** "V"
- **Direction of rotation:** Clockwise, looking towards rotor
- **Degree of protection:** Ⓐ Ⓒ IP 44, Ⓑ Ⓓ IP 20, depending on installation and position
- **Insulation class:** "B"
- **Installation position:** Any
- **Condensation drainage holes:** Ⓐ Ⓒ none, Ⓑ Ⓓ seen on rotor
- **Mode of operation:** Continuous operation (S1)
- **Bearings:** Maintenance-free ball bearings

VJH0200XUNES

Nominal data

Type	Motor	Curve	Nominal voltage		Air flow	Nominal speed	Power consumption	Input current	Sound power level	Admissible amb. temp.	Weight	Technical features and connection diagram
			VDC	VDC								
K3G 200-BD46-04	M3G 074-CF	Ⓐ	24	16...28	1240	4120	170	7.0	80	-25...+60	2.3	p. 277 / J5)
K3G 200-BD44-02	M3G 074-CF	Ⓑ	24	16...28	1445	4830	275	11.5	84	-25...+60	2.3	p. 277 / J5)
K3G 200-BD64-04	M3G 074-CF	Ⓒ	48	36...57	1475	4875	275	5.8	85	-25...+60	2.3	p. 277 / J5)
K3G 200-BDA8-02	M3G 074-CF	Ⓓ	48	36...57	1650	5470	400	8.4	88	-25...+60	2.3	p. 277 / J5)

Subject to change

Curves:

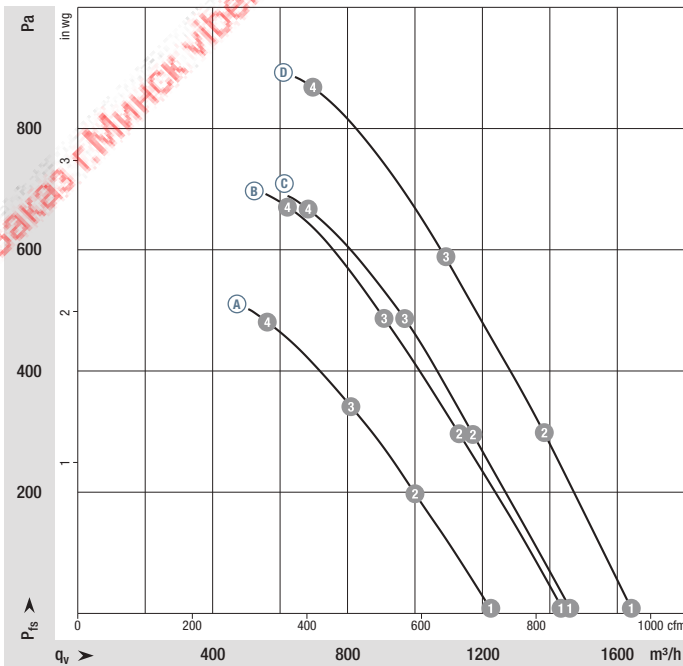

	n	P _{ed}	I	L _{WA}
	rpm ⁻¹	W	A	dB(A)
Ⓐ 1	4120	170	7.00*	80
Ⓐ 2	4025	180	7.52*	77
Ⓐ 3	4005	187	7.80*	76
Ⓐ 4	4045	187	7.78*	78
Ⓑ 1	4830	275	11.50*	84
Ⓑ 2	4720	294	12.24*	81
Ⓑ 3	4685	299	12.48*	80
Ⓑ 4	4715	295	12.30*	83
Ⓒ 1	4875	275	5.80*	85
Ⓒ 2	4795	300	6.27*	81
Ⓒ 3	4755	307	6.41*	80
Ⓒ 4	4780	304	6.35*	82
Ⓓ 1	5470	400	8.40*	88
Ⓓ 2	5365	426	8.89*	85
Ⓓ 3	5310	438	9.17*	83
Ⓓ 4	5355	431	9.01*	87

* Current measured at nominal voltage.

Air performance measured according to: ISO 5801. Installation category A, without contact protection. Suction-side noise levels: LWA according to ISO 13347, LpA measured at 1 m distance from fan axis. The values given are applicable only under the specified measuring conditions and may differ depending on the installation conditions. In the event of deviation from the standard configuration, the parameters must be checked after installation! For detailed information see <http://www.ebmpapst.com/general-conditions>

- **Technical features:** See connection diagram p. 277
- **EMC (48 V):** Immunity to interference according to EN 61000-6-2 (industrial environment)
Interference emission according to EN 55022 (Class B, household environment)
- **Cable exit:** Lateral
- **Conformity with standard(s):** EN 60335-1
- **Approvals:** (24 V) EAC
(48 V) EAC, CCC

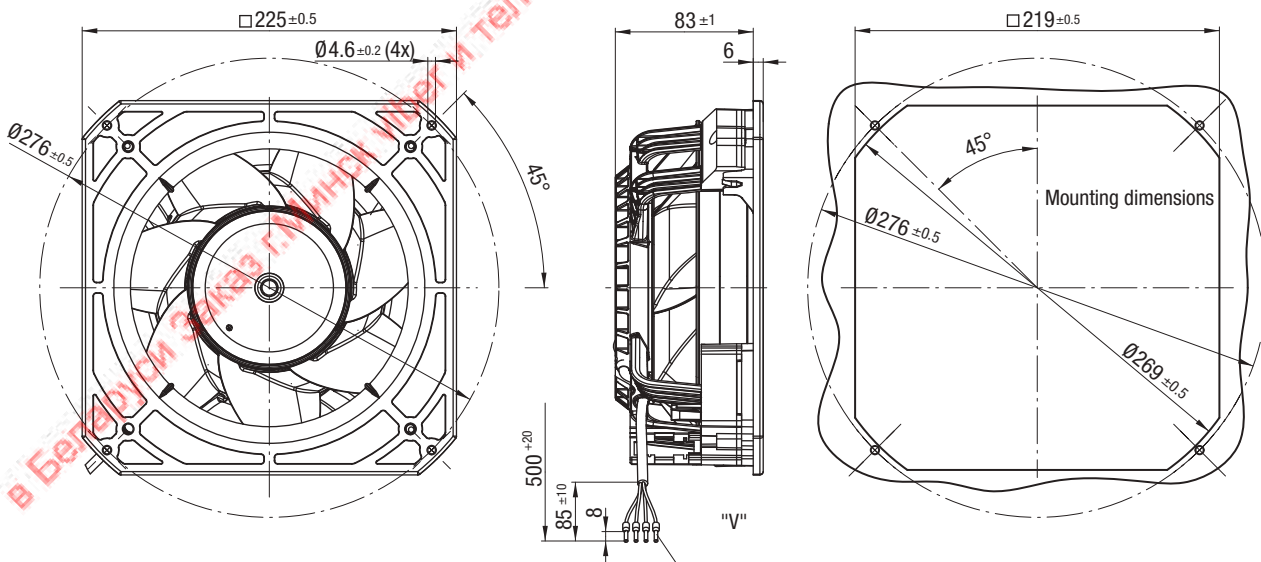

Cable assignment:
 Red = UN
 Yellow = 0-10 VDC
 White = tach output
 Blue = GND

PVC AWG 16 cable
 4x crimped ferrules

Max. 2070 m³/h

DC axial fans

Ø 250 mm



- **Material:** Fan housing: Die-cast aluminum
Blades: Plastic (PP)
Rotor: Thick-film passivated
- **Number of blades:** 7
- **Direction of air flow:** "V"
- **Direction of rotation:** Counterclockwise, looking towards rotor
- **Insulation class:** "B"
- **Installation position:** Any
- **Condensation drainage holes:** On rotor side
- **Mode of operation:** Continuous operation (S1)
- **Bearings:** Maintenance-free ball bearings

WWT250XUNCS

Nominal data

Type	Motor	Curve	Nominal voltage VDC	Nominal voltage range VDC	Air flow m ³ /h	Nominal speed rpm ⁻¹	Power consumption W	Input current A	Max. back-pressure Pa	Admissible amb. temp. °C	Technical features and connection diagram
W1G250-HJ87 -02	M1G074-BF	Ⓐ	24	16-28	2070	3090	120	7.00	150	-25...+60	p. 273 / E
W1G250-HJ20 -02	M1G074-BF	Ⓑ	48	36-57	2070	3100	130	3.80	140	-25...+60	p. 273 / E

Subject to change

Curves:

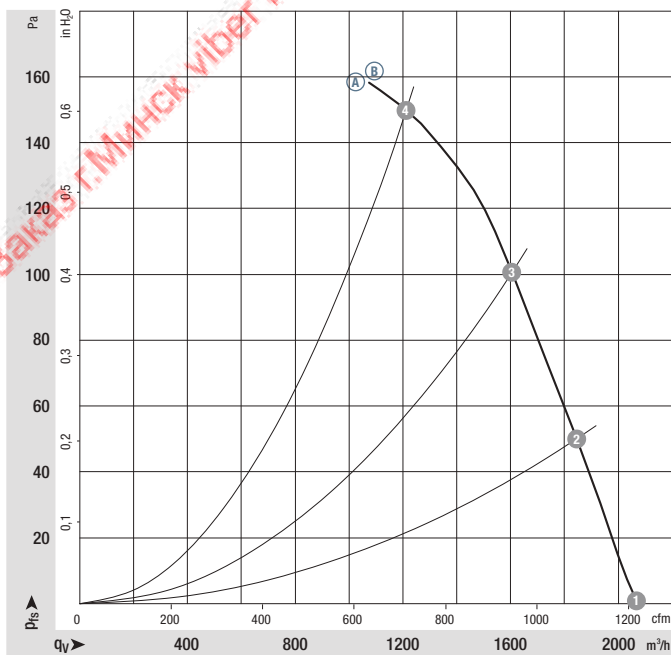

	n rpm ⁻¹	P _{ed} W	I A	L _{WA} dB(A)
Ⓐ 1	3090	120	6.80	74
Ⓐ 2	2950	124	7.10	73
Ⓐ 3	2820	127	7.43	73
Ⓐ 4	2730	130	7.80	78
Ⓑ 1	3100	130	3.80	74
Ⓑ 2	2945	133	4.10	73
Ⓑ 3	2810	135	4.20	73
Ⓑ 4	2720	136	4.20	78

Air performance measured according to: ISO 5801. Installation category A, without contact protection. Suction-side noise levels: L_{WA} according to ISO 13347, L_{pA} measured at 1 m distance from fan axis. The values given are applicable only under the specified measuring conditions and may differ depending on the installation conditions. In the event of deviation from the standard configuration, the parameters must be checked after installation! For detailed information see <http://www.ebmpapst.com/general-conditions>

- **Technical features:** See connection diagram p. 273
- **EMC:** Interference emission acc. to EN 55022 (Class B)
Immunity to interference acc. to EN 61000-6-2 (industrial environment)
- **Electrical hookup:** Via terminal strip
- **Protection class:** I
- **Conformity with standard(s):** EN 60950-1

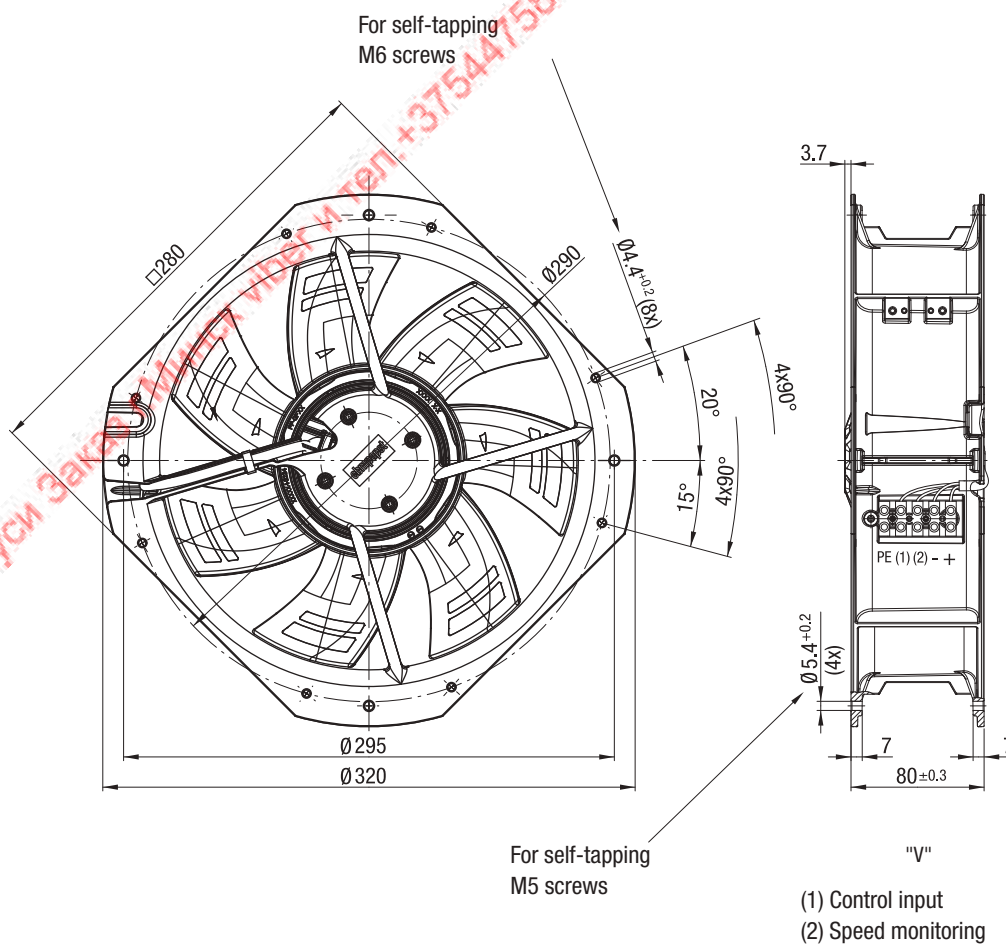

Max. 2345 m³/h

DC axial fans – HyBlade®

Ø 300 mm



- **Material:** Finger guard: Steel, phosphated and coated in black plastic
Fan housing: Sheet steel, pre-galvanized and coated in black plastic
Blades: Plastic (PP)
Rotor: Painted black
- **Number of blades:** 5
- **Direction of air flow:** "V"
- **Direction of rotation:** Counterclockwise, looking towards rotor
- **Degree of protection:** IP 42
- **Insulation class:** "B"
- **Installation position:** Any
- **Condensation drainage holes:** None
- **Mode of operation:** Continuous operation (S1)
- **Bearings:** Maintenance-free ball bearings

VVY0300XUNES
VWR0300XUNES
VMA0300XUNES

Nominal data

Type	Motor	Curve	Nominal voltage VDC	Nominal voltage range VDC	Air flow m ³ /h	Nominal speed rpm ⁻¹	Power consumption W	Input current A	Max. back-pressure Pa	Admissible amb. temp. °C	Technical features and connection diagram
*1G 300	M1G 074-CF	Ⓐ	24	16-28	2320	1830	80	3.80	100	-25..+60	p. 277 / J5)
*1G 300	M1G 074-CF	Ⓑ	48	36-57	2345	1830	80	1.90	100	-25..+60	p. 277 / J5)

Subject to change

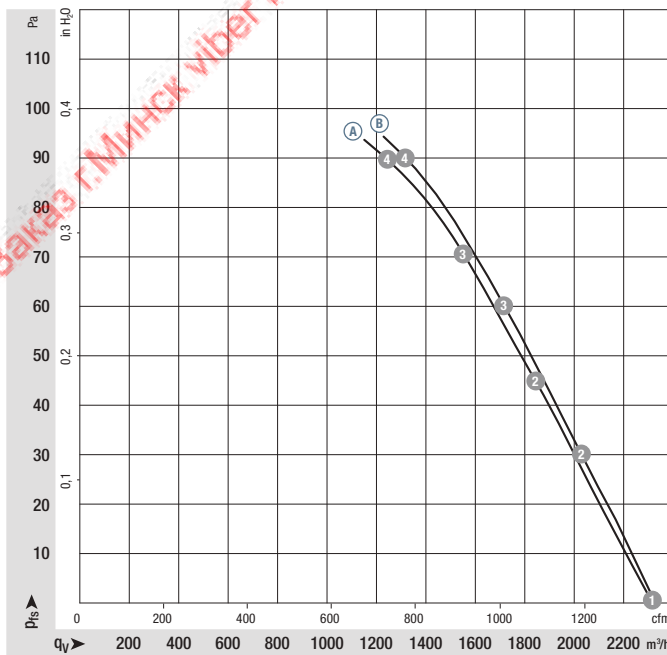

Curves:



	n rpm ⁻¹	P _{ed} W	I A	L _{wA} dB(A)
Ⓐ 1	1810	80	3.80	67
Ⓐ 2	1730	86	4.03	67
Ⓐ 3	1690	87	4.10	66
Ⓐ 4	1635	89	4.21	70
Ⓑ 1	1870	87	2.00	68
Ⓑ 2	1805	90	2.10	67
Ⓑ 3	1765	91	2.13	67
Ⓑ 4	1695	92	2.19	69

Air performance measured according to: ISO 5801, installation category A, in ebm-papst full nozzle without contact protection. Suction-side noise levels: LWA according to ISO 13347, L_{wA} measured at 1 m distance from fan axis. The values given are applicable only under the specified measuring conditions and may differ depending on the installation conditions. In the event of deviation from the standard configuration, the parameters must be checked after installation! For detailed information see <http://www.ebmpapst.com/general-conditions>

- **Technical features:** See connection diagram p. 277
- **EMC:** Interference emission acc. to EN 55022 (Class B)
Immunity to interference acc. to EN 61000-6-2 (industrial environment)
- **Cable exit:** Lateral
- **Conformity with standard(s):** EN 60950-1, UL 1004-1, CSA C22.2 no. 100
- **Approvals:** GOST, UL

Airflow direction		Weight without attachments		Weight with full round nozzle		Weight with finger guard for short nozzle
	without attachments	kg	With full round nozzle	kg	With finger guard for short nozzle	kg
"V"	A1G 300-AC19 -54	1.8	W1G300-DC19 -54	3.8	S1G 300-AC19 -54	2.8
"V"	A1G 300-AC33 -54	1.8	W1G300-DC33 -54	3.8	S1G 300-AC33 -54	3.1

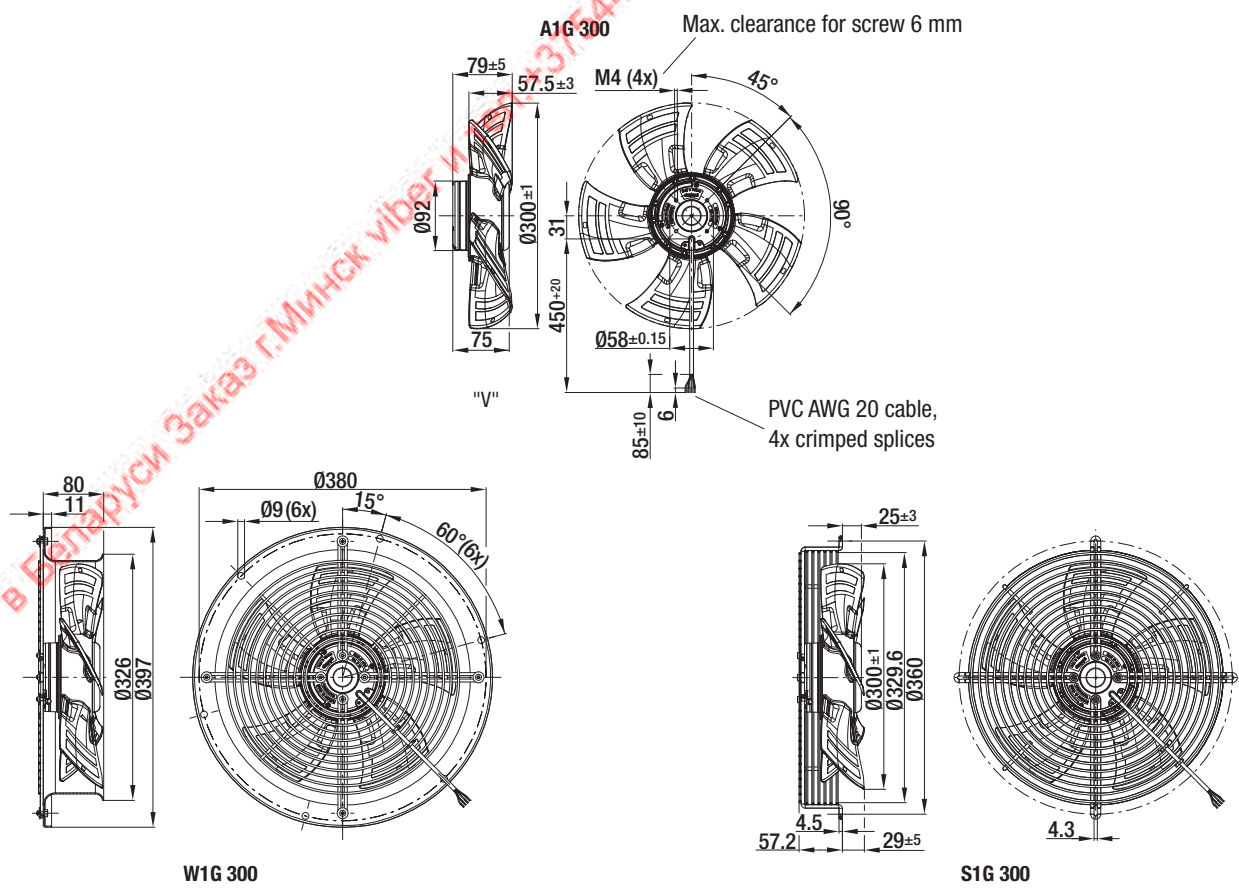

Centrifugal fans for DC operation

Overview of air performance

Dimension	Series	Air flow	Air flow																Page								
			10	20	30	40	50	60	70	80	90	100	200	300	400	500	600	700		800	900	1000	2000	2500			
mm		m³/h																									
□ 51 x 15	RLF 35	9.6																									95
□ 76 x 27	RL 48	22...28																									96
□ 97 x 93.5 x 33	RL 65	56...61																									97
□ 121 x 37	RL 90 N	40...55																									98
□ 127 x 25	RLF 100	64...80																									99
□ 135 x 38	RG 90 N	55																									100
□ 180 x 40	RG 125 N	60...137																									101
□ 180 x 40	RG 140 NTD	118																									102
□ 220 x 56	RG 160 N	139...209																									103
□ 220 x 56	RG 160 NTD	59...444																									104
<i>S-Force</i> □ 226 x 85	RG 190 TD	630...930																									105
<i>S-Force</i> □ 270 x 99	RG 220 TD	1100																									106
<i>S-Force</i> □ 270 x 119	RG 225 TD	1090...1450																									107
∅ 85 x 68	RET 85	94																									108
∅ 97 x 41	RET 97 TD	220																									109
<i>S-Force</i> ∅ 104 x 25	REF 100	86...104																									110
∅ 101 x 52	RER 101 N	162...190																									111
<i>S-Force</i> ∅ 120 x 54	RER 120 TD	320...390																									112
∅ 120	R1G 120	250																									114
∅ 138 x 35	RER 125 N	110...166																									116
<i>S-Force</i> ∅ 133 x 91	RER 133 TD	460...565																									117
∅ 140 x 36	RER 140 TD	225																									118
∅ 165 x 51	RER 160 N	255																									119
<i>S-Force</i> ∅ 165 x 51	RER 160 NTD	360																									120
<i>S-Force</i> ∅ 175 x 55	REF 175 TD	800																									121
<i>S-Force</i> ∅ 175 x 69	RER 175 TD	600...980																									122
<i>S-Force</i> ∅ 190 x 69	RER 190 TD	650...970																									123
∅ 190	R1G 190	565...820																									124
∅ 190	R3G 190	880...930																									126
∅ 220	R1G 220	925...1080																									128
∅ 220	R3G 220	1200...1215																									130
<i>S-Force</i> ∅ 220 x 71	RER 220 TD	1063...1250																									132
<i>S-Force</i> ∅ 225 x 99	RER 225 TD	1190...1600																									133
∅ 225	R1G 225	990...1130																									134
∅ 225	R3G 225	1300...1340																									136
∅ 250	R1G 250	1035...1505																									138
∅ 250	R3G 250	1505...1640																									140
∅ 280	R1G 280	1780...2120																									142
∅ 280	R3G 280	2160...2190																									144
∅ 310	R3G 310	2310...2380																									146
201...413 x 50 x 48	QG Q30	75...155																									148
∅ 85	*1G 085	95																									150
∅ 97	*1G 097	95																									152
∅ 108	*1G 108	200																									154
∅ 120	*1G 120	255																									156
∅ 133	*1G 133	225																									158
∅ 140	*1G 140	400...410																									160
∅ 146	*1G 146	465...470																									162
∅ 160	*1G 160	505																									164
∅ 133	D1G 133	700																									166
∅ 133	D1G 133	1020																									168
∅ 146	D1G 146	1000																									170
∅ 160	D1G 160	980																									172

Subject to change

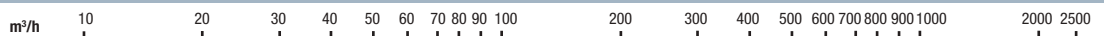

Centrifugal fans for DC operation

Overview of technically feasible designs

Dimension	Centrifugal fans										Page						
	mm	Series	VDE, UL, CSA	Speed signal	Go / NoGo alarm	Alarm with speed limit	External temperature sensor	Internal temperature sensor	PWM control input	Analog control input		Multi-options control input	Moisture protection	IP >= 54	IP 68	Salt spray protection	
	□ 51 x 15	RLF 35	ja ■	•	-	-	-	-	•	-	-	-	-	-	-	-	95
	□ 76 x 27	RL 48	ja ■	•	•	•	•	•	•	•	•	-	•	-	-	-	96
	97 x 93,5 x 33	RL 65	ja ■	•	•	•	•	•	•	•	•	-	•	-	-	-	97
	□ 121 x 37	RL 90 N	ja □/■	•	•	•	•	•	•	•	•	-	•	•	•	•	98
	□ 127 x 25	RLF 100	ja ■	•	•	•	•	•	•	•	•	-	•	•	-	-	99
	□ 135 x 38	RG 90 N	ja □/■	•	•	•	•	•	•	•	•	-	•	•	•	•	100
	□ 180 x 40	RG 125 N	ja ■	•	•	•	•	•	•	•	•	-	•	•	•	•	101
	□ 180 x 40	RG 140 NTD	ja ■	•	•	•	•	-	•	•	•	-	•	•	•	•	102
	□ 220 x 56	RG 160 N	ja ■	•	•	•	•	•	•	•	•	-	•	•	-	•	103
	□ 220 x 56	RG 160 NTD	ja ■	•	•	•	•	•	•	•	•	-	•	•	-	•	104
<i>S-Force</i>	□ 226 x 85	RG 190 TD	ja ■	•	•	•	•	•	•	•	•	-	•	•	-	•	105
<i>S-Force</i>	□ 270 x 99	RG 220 TD	ja ■	•	•	•	•	•	•	•	•	-	•	•	-	•	106
<i>S-Force</i>	□ 270 x 119	RG 225 TD	ja ■	•	•	•	•	•	•	•	•	-	•	•	-	•	107
	∅ 85 x 68	RET 85 TD	ja ■	•	•	•	•	•	•	•	•	-	•	-	-	-	108
<i>S-Force</i>	∅ 97 x 41	RET 97 TD	ja ■	•	•	•	•	•	•	•	•	-	•	-	-	-	109
	∅ 104 x 25	REF 100	ja ■	•	•	•	•	•	•	•	•	-	•	•	-	-	110
	∅ 101 x 52	RER 101 N	ja ■	•	•	•	•	•	•	•	•	-	•	-	-	-	111
<i>S-Force</i>	∅ 120 x 54	RER 120 TD	ja ■	•	•	•	•	•	•	•	•	-	•	-	-	-	112
	∅ 138 x 35	RER 125 N	ja ■	•	•	•	•	•	•	•	•	-	•	•	•	•	116
<i>S-Force</i>	∅ 133 x 91	RER 133 TD	ja ■	•	•	•	•	•	•	•	•	-	•	-	-	•	117
	∅ 140 x 36	RER 140 TD	ja ■	•	•	•	•	•	•	•	•	-	•	•	-	•	118
<i>S-Force</i>	∅ 165 x 51	RER 160 N	ja ■	•	•	•	•	•	•	•	•	-	•	•	-	•	119
<i>S-Force</i>	∅ 165 x 51	RER 160 NTD	ja ■	•	•	•	•	•	•	•	•	-	•	•	-	-	120
<i>S-Force</i>	∅ 175 x 55	REF 175 TD	ja ■	•	•	•	•	•	•	•	•	-	•	•	-	-	121
<i>S-Force</i>	∅ 175 x 69	RER 175 TD	ja ■	•	•	•	•	•	•	•	•	-	•	•	-	•	122
<i>S-Force</i>	∅ 190 x 69	RER 190 TD	ja ■	•	•	•	•	•	•	•	•	-	•	•	-	•	123
<i>S-Force</i>	∅ 220 x 71	RER 220 TD	ja ■	•	•	•	•	•	•	•	•	-	•	•	-	•	132
<i>S-Force</i>	∅ 225 x 99	RER 225 TD	ja ■	•	•	•	•	•	•	•	•	-	•	•	-	•	133
	201...413 x 50 x 48	QG 030	ja □/■	•	-	-	-	-	-	-	-	-	•	-	-	-	148
	Subject to change																

- Not yet available □ Sleeve bearings
 • Available ■ Ball bearings

Please note that these special versions are not possible for all voltages and speeds, and not in all combinations. The special versions are designed for specific customers and projects. As a rule they are not available off the shelf and are subject to minimum volumes.

Please consult your customer support representative about the feasibility of your special variant.

Optional special versions (see page 10)

On the catalog pages and in the overview on page 10, we provide information about the special designs that are technically feasible in the fan series. Please note that these special versions are not possible for all voltages and speeds, and not in all combinations. The special

versions are designed for specific customers and projects and are usually not available off the shelf.

Max. 9.6 m³/h

DC centrifugal fans

□ 51 x 15 mm

Information

DC axial fans

DC centrifugal fans

DC fans - specials

ACmaxx / EC axial fans

AC axial fans

AC centrifugal fans

Accessories

Representatives



- **Material:** Scroll housing: GRP¹⁾
Impeller: GRP¹⁾
 - **Direction of air flow:** Axial: Intake,
Centrifugal: Exhaust
 - **Connection:** via single wires AWG 26, TR 64
 - **Highlights:** Forward-curved impeller
 - **Weight:** 40 g
- **Possible special versions:**
(See chapter DC fans - specials)
 - Speed signal
 - PWM control input
 - Moisture protection

1) Fiberglass-reinforced plastic

Series RLF 35
VHS0035XUDAS

Nominal data

Type	Air flow		Nominal voltage	Voltage range	Sound power level	Sinter sleeve bearings Ball bearings	Power consumption	Nominal speed	Temperature range	Service life L ₁₀ (40 °C) ebm-papst standard	Service life L ₁₀ (T _{max}) ebm-papst standard	Life expectancy L ₁₀ IPC (40 °C) see page 15	Curve
	m ³ /h	cfm											
RLF 35-8/12 N	9.6	5.6	12	8...13.2	5.5	■	3.5	6 700	-20...+70	60 000 / 30 000	102 500	①	
RLF 35-8/14 N	9.6	5.6	24	14...28	5.5	■	4.3	6 700	-20...+70	60 000 / 30 000	102 500	①	

Subject to change

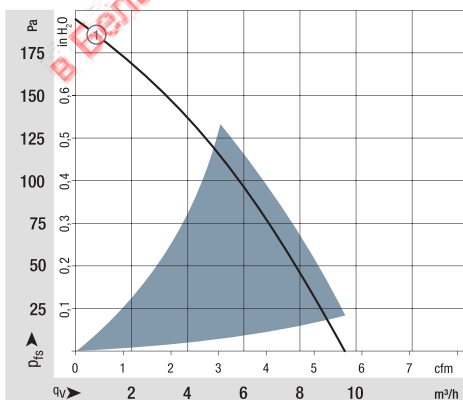

Air performance measured according to: ISO 5801.
Installation category A, without contact protection.
Noise: Total sound power level L_{WA} ISO 10302 measured on a hemisphere with a radius of 2 m.
Sound pressure level L_{pA} measured at 1 m distance from fan axis.
The values given are applicable only under the specified measuring conditions and may differ depending on the installation conditions.
In the event of deviation from the standard configuration, the parameters must be checked after installation!
For detailed information see
<http://www.ebmpapst.com/general conditions>

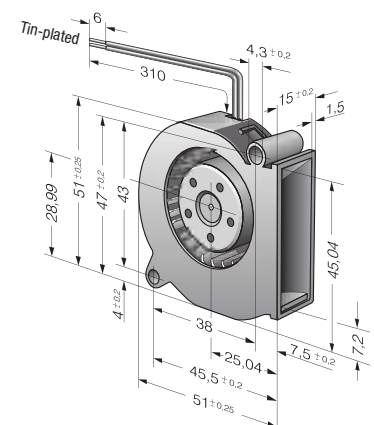

Max. 28 m³/h

DC centrifugal fans

□ 76 x 27 mm



- **Material:** Scroll housing: GRP¹⁾
Impeller: GRP¹⁾
 - **Direction of air flow:** Axial: Intake,
Centrifugal: Exhaust
 - **Connection:** via single wires AWG 26, TR 64
 - **Highlights:** Forward-curved impeller
 - **Weight:** 75 g
- **Possible special versions:**
(See chapter DC fans - specials)
 - Speed signal
 - Go- / NoGo alarm
 - Alarm with speed limit
 - External temperature sensor
 - Internal temperature sensor
 - PWM control input
 - Analog control input
 - Moisture protection

1) Fiberglass-reinforced plastic

Series RL 48
VHS0048XUEBS

Nominal data

Type	Air flow		Nominal voltage	Voltage range		Sound power level	Sinter sleeve bearings Ball bearings	Power consumption	Nominal speed	Temperature range	Service life L ₁₀ (40 °C) ebm-papst standard	Service life L ₁₀ (T _{max}) ebm-papst standard	Life expectancy L ₁₀ IPC (40 °C) see page 15	Curve
	m ³ /h	cfm		VDC	VDC									
RL 48-19/12 ML	22	12.9	12	8...15	5.3	■	5.0	3 500	-20...+70	70 000 / 35 000	117 500	①		
RL 48-19/12	28	16.5	12	8...13.5	5.7	■	4.6	4 400	-20...+70	60 000 / 30 000	102 500	②		
RL 48-19/14 ML	22	12.9	24	18...28	5.3	■	5.0	3 500	-20...+70	70 000 / 35 000	117 500	①		
RL 48-19/14	28	16.5	24	18...26.4	5.7	■	4.4	4 400	-20...+70	60 000 / 30 000	102 500	②		
RL 48-19/18 R-016	27	15.8	48	36...56	5.7	■	4.6	4 400	-32...+70	60 000 / 30 000	102 500	②		

Subject to change

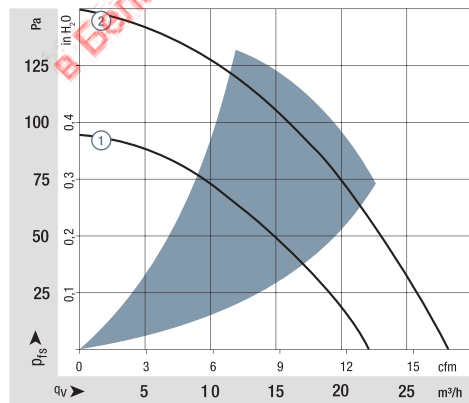

Air performance measured according to: ISO 5801.
Installation category A, without contact protection.
Noise: Total sound power level L_{WA} ISO 10302 measured on a hemisphere with a radius of 2 m.
Sound pressure level L_{PA} measured at 1 m distance from fan axis.
The values given are applicable only under the specified measuring conditions and may differ depending on the installation conditions.
In the event of deviation from the standard configuration, the parameters must be checked after installation!
For detailed information see <http://www.ebmpapst.com/general conditions>

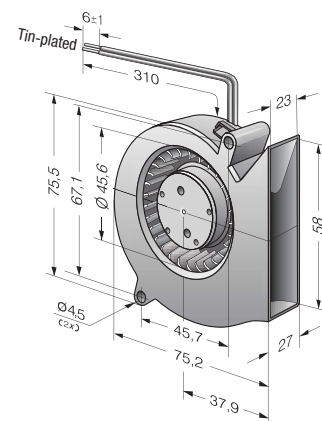

Max. 61 m³/h

DC centrifugal fans

97 x 93.5 x 33 mm



- **Material:** Scroll housing: GRP¹⁾
Impeller: GRP¹⁾
 - **Direction of air flow:** Axial: Intake,
Centrifugal: Exhaust
 - **Connection:** via single wires AWG 26, TR 64
 - **Highlights:** Forward-curved impeller
 - **Weight:** 170 g
- **Possible special versions:**
(See chapter DC fans - specials):
 - Speed signal
 - Go / NoGo alarm
 - Alarm with speed limit
 - External temperature sensor
 - Internal temperature sensor
 - PWM control input
 - Analog control input
 - Moisture protection

1) Fiberglass-reinforced plastic

Series RL 65
VHS0065XUFBS

Nominal data

Type	Air flow		Nominal voltage	Voltage range		Sound power level	Sinter sleeve bearings Ball bearings	Power consumption	Nominal speed	Temperature range	Service life L ₁₀ (40 °C) ebm-papst standard	Service life L ₁₀ (T max) ebm-papst standard	Life expectancy L ₁₀ (IPC (40 °C) see page 15	Curve
	m ³ /h	cfm		VDC	VDC									
RL 65-21/12	56	32.9	12	6.8...13.8	6.6	■	15.0	4 500	-20...+70	60 000 / 30 000	102 500	①		
RL 65-21/12 H	61	35.8	12	6.8...13.2	6.8	■	19.2	4 900	-20...+55	55 000 / 40 000	92 500	②		
RL 65-21/14	56	32.9	24	12...26.4	6.6	■	14.0	4 500	-20...+70	60 000 / 30 000	102 500	①		
RL 65-21/14 H	61	35.8	24	12...26.4	6.8	■	18.0	4 900	-20...+60	55 000 / 35 000	92 500	②		
RL 65-21/18/2 HPR-180	61	35.8	48	36...60	6.8	■	17.3	4 900	-20...+70	55 000 / 27 500	92 500	②		

Subject to change

Snap-in fins for easy latch

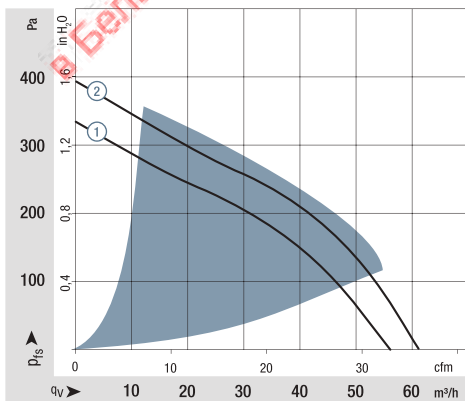
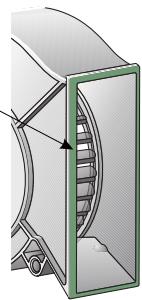

Air performance measured according to: ISO 5801.
Installation category A, without contact protection.
Noise: Total sound power level L_{WA} ISO 10302 measured on a hemisphere with a radius of 2 m.
Sound pressure level L_{pA} measured at 1 m distance from fan axis.
The values given are applicable only under the specified measuring conditions and may differ depending on the installation conditions.
In the event of deviation from the standard configuration, the parameters must be checked after installation!
For detailed information see <http://www.ebmpapst.com/general-conditions>

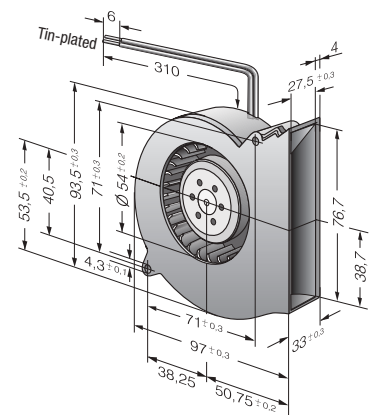

Max. 55 m³/h

DC centrifugal fans

□ 121 x 37 mm



- **Material:** Scroll housing: GRP¹⁾
Impeller: GRP¹⁾
Base plate: Sheet steel
 - **Direction of air flow:** Axial: Intake,
Centrifugal: Exhaust
 - **Connection:** via single wires AWG 22, TR 64
 - **Highlights:** Forward-curved impeller
 - **Weight:** 420 g
- **Possible special versions:** (See chapter DC fans - specials)
 - Speed signal
 - Go / NoGo alarm
 - Alarm with speed limit
 - External temperature sensor
 - Internal temperature sensor
 - PWM control input
 - Analog control input
 - Moisture protection
 - Salt spray protection
 - Degree of protection: IP 54 / IP 68

1) Fiberglass-reinforced plastic

Series RL 90 N
VHS0090XUJBS

Nominal data

Type	Air flow		Nominal voltage	Voltage range		Sound power level	Sintec sleeve bearings Ball bearings	Power consumption	Nominal speed	Temperature range	Service life L ₁₀ (40 °C) ebm-papst standard	Service life L ₁₀ (T max) ebm-papst standard	Life expectancy L ₁₀ IPC (40 °C) see page 15	Curve
	m ³ /h	cfm		VDC	VDC									
RL 90-18/12 N	40	23.5	12	7...15	5.8	■	6.3	2 500	-30...+75	62 500 / 27 500	105 000	①		
RL 90-18/14 NG	40	23.5	24	12...28	5.8	□	5.6	2 500	-20...+75	62 500 / 27 500	105 000	①		
RL 90-18/14 N	40	23.5	24	12...28	5.8	■	5.6	2 500	-30...+75	62 500 / 27 500	105 000	①		
RL 90-18/18 NH	55	32.4	48	36...53	6.9	■	14.7	3 500	-30...+65	32 500 / 17 500	55 000	②		

Subject to change

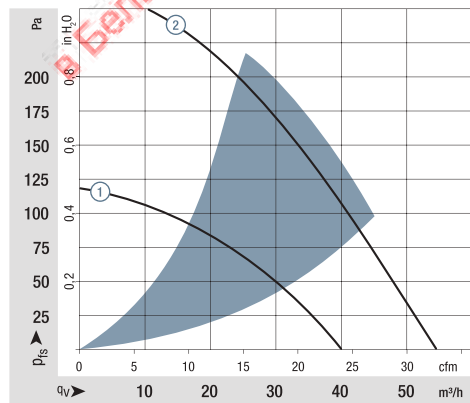

Air performance measured according to: ISO 5801.
Installation category A, without contact protection.
Noise: Total sound power level L_{wA} ISO 10302 measured on a hemisphere with a radius of 2 m; Sound pressure level L_{pA} measured at 1 m distance from fan axis.
The acoustic values are only valid for the described measurement setup and may vary depending on the installation situation.
In the event of deviation from the standard configuration, the parameters must be checked after installation!
For detailed information see <http://www.ebmpapst.com/general-conditions>

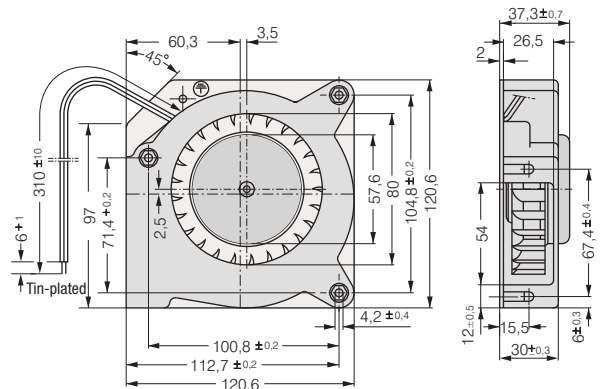

Screw clip M4 or 8-32UNC. Screw-in depth max. 12.5 min. 9.0

Max. 80 m³/h

DC centrifugal fans

□ 127 x 25 mm



- **Material:** Scroll housing: GRP¹⁾
Impeller: GRP¹⁾
Base plate: Sheet steel
 - **Direction of air flow:** Axial: Intake,
Centrifugal: Exhaust
 - **Connection:** via single wires AWG 22, TR 64
 - **Highlights:** Optional protective cap for outlet opening
Backward-curved impeller
 - **Weight:** 320 g
- **Possible special versions:** (See chapter DC fans - specials)
 - Speed signal
 - Go / NoGo alarm
 - Alarm with speed limit
 - External temperature sensor
 - Internal temperature sensor
 - PWM control input
 - Analog control input
 - Moisture protection
 - Degree of protection: IP 54

1) Fiberglass-reinforced plastic

Series RLF 100
VCS0100XUGBS

Nominal data

Type	Air flow		Nominal voltage	Voltage range		Sound power level	Sinter sleeve bearings Ball bearings	Power consumption	Nominal speed	Temperature range	Service life L ₁₀ (40 °C) ebm-papst standard	Service life L ₁₀ (T max) ebm-papst standard	Life expectancy L ₁₀ IPC (40 °C) see page 15	Curve
	m ³ /h	cfm		VDC	VDC									
RLF 100-11/12	64	37.7	12	8...15	6.4	■	8.0	5 100	-20...+75	80 000 / 30 000	135 000	①		
RLF 100-11/14	64	37.7	24	16...30	6.4	■	8.0	5 100	-20...+75	80 000 / 30 000	135 000	①		
RLF 100-11/18	64	37.7	48	36...60	6.4	■	8.6	5 100	-20...+75	80 000 / 30 000	135 000	①		
High speed models with open-collector tachometer and PWM speed control.														
RLF 100-11/12/2 HP-200	80	47.1	12	10...13.2	7.5	■	18.6	6 400	-20...+60	72 500 / 45 000	122 500	②		
RLF 100-11/18/2 HP-182	80	47.1	48	43...53	7.5	■	17.0	6 400	-20...+70	72 500 / 35 000	122 500	②		

Subject to change

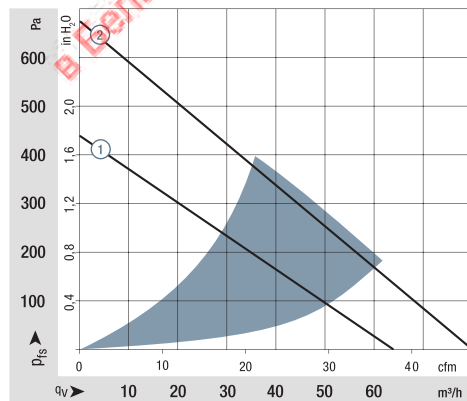

Air performance measured according to: ISO 5801.
Installation category A, without contact protection.
Noise: Total sound power level L_{WA} ISO 10302 measured on a hemisphere with a radius of 2 m.
Sound pressure level L_{pA} measured at 1 m distance from fan axis.
The values given are applicable only under the specified measuring conditions and may differ depending on the installation conditions.
In the event of deviation from the standard configuration, the parameters must be checked after installation!
For detailed information see <http://www.ebmpapst.com/general conditions>

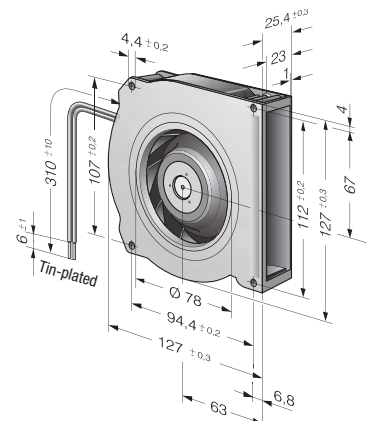

Max. 55 m³/h

DC centrifugal fans

□ 135 x 38 mm



- **Material:** Scroll housing: GRP¹⁾
Impeller: GRP¹⁾
Base plate: Sheet steel
 - **Direction of air flow:** Axial: Intake,
Centrifugal: Exhaust
 - **Connection:** Via single wires AWG 22, TR 64
48 V model: Flat plug
6.3 x 0.8 mm for ground
conductor
 - **Highlights:** Forward-curved impeller
 - **Weight:** 440 g
- **Possible special versions:**
(See chapter DC fans - specials)
 - Speed signal
 - Go / NoGo alarm
 - Alarm with speed limit
 - External temperature sensor
 - Internal temperature sensor
 - PWM control input
 - Analog control input
 - Moisture protection
 - Salt spray protection
 - Degree of protection: IP 54 / IP 68

1) Fiberglass-reinforced plastic

Series RG 90 N
VHS0090XUJBS

Nominal data

Type	Air flow		Nominal voltage	Voltage range		Sound power level	Sintec sleeve bearings Ball bearings	Power consumption	Nominal speed	Temperature range	Service life L ₁₀ (40 °C) ebm-papst standard	Service life L ₁₀ (T max) ebm-papst standard	Life expectancy L ₁₀ IPC (40 °C) see page 15	Curve
	m ³ /h	cfm		VDC	VDC									
RG 90-18/12 N	55	32.4	12	7...15	5.5	■	6.7	2 200	-30...+75	62 500 / 27 500	105 000	①		
RG 90-18/14 N	55	32.4	24	12...28	5.5	■	6.2	2 200	-30...+75	62 500 / 27 500	105 000	①		
RG 90-18/18 N	55	32.4	48	36...56	5.5	■	6.1	2 200	-30...+75	62 500 / 27 500	105 000	①		

Subject to change

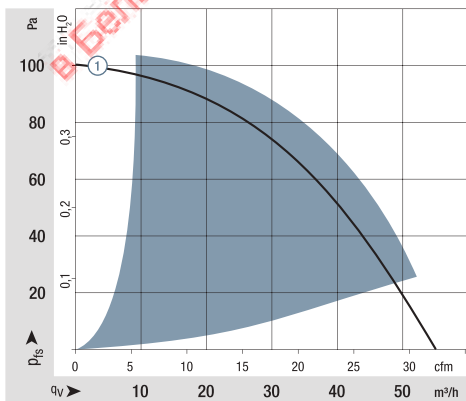

Air performance measured according to: ISO 5801.
Installation category A, without contact protection.
Noise: Total sound power level L_{WA} ISO 10302 measured on a hemisphere with a radius of 2 m.
Sound pressure level L_{pA} measured at 1 m distance from fan axis.
The values given are applicable only under the specified measuring conditions and may differ depending on the installation conditions.
In the event of deviation from the standard configuration, the parameters must be checked after installation!
For detailed information see <http://www.ebmpapst.com/general conditions>

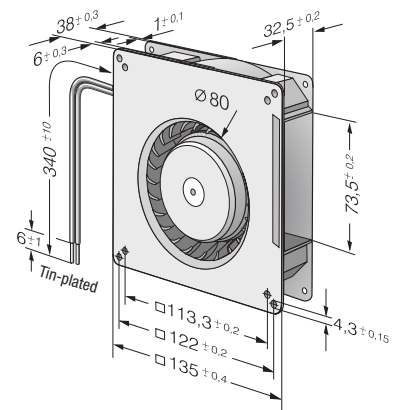

Max. 137 m³/h

DC centrifugal fans

□ 180 x 40 mm



- **Material:** Scroll housing: GRP¹⁾
Impeller: GRP¹⁾
Base plate: Sheet steel
 - **Direction of air flow:** Axial: Intake,
Centrifugal: Exhaust
 - **Connection:** Via single wires AWG 22, TR 64
48 V model: Flat plug
6.3 x 0.8 mm for ground
conductor
 - **Highlights:** Backward-curved impeller
 - **Weight:** 730 g
- **Possible special versions:**
(See chapter DC fans - specials)
 - Speed signal
 - Go / NoGo alarm
 - Alarm with speed limit
 - External temperature sensor
 - Internal temperature sensor
 - PWM control input
 - Analog control input
 - Moisture protection
 - Salt spray protection
 - Degree of protection: IP 54 / IP 68

1) Fiberglass-reinforced plastic

Series RG 125 N
VCS0125XUJBS

Nominal data

Type	Air flow		Nominal voltage	Voltage range		Sound power level	Sinter sleeve bearings Ball bearings	Power consumption	Nominal speed	Temperature range	Service life L ₁₀ (40 °C) ebm-papst standard	Service life L ₁₀ (T max) ebm-papst standard	Life expectancy L ₁₀ (IPC (40 °C) see page 15	Curve
	m ³ /h	cfm		VDC	VDC									
RG 125-19/12 NM	60.0	35.3	12	7...15	4.8	■	2.0	1 750	-30...+75	70 000 / 30 000	117 500	①		
RG 125-19/12 N	87.5	51.5	12	7...15	5.8	■	5.2	2 550	-30...+75	62 500 / 27 500	105 000	②		
RG 125-19/14 NM	60.0	35.3	24	12...28	4.8	■	2.0	1 750	-30...+75	70 000 / 30 000	117 500	①		
RG 125-19/14 N	87.5	51.5	24	12...28	5.8	■	4.9	2 550	-30...+75	62 500 / 27 500	105 000	②		
RG 125-19/18 N	87.5	51.5	48	36...56	5.8	■	4.8	2 550	-30...+75	62 500 / 27 500	105 000	②		
RG 125-19/18 NH	137	80.6	48	36...56	7.0	■	19.0	4 000	-20...+70	55 000 / 27 500	92 500	③		

Subject to change

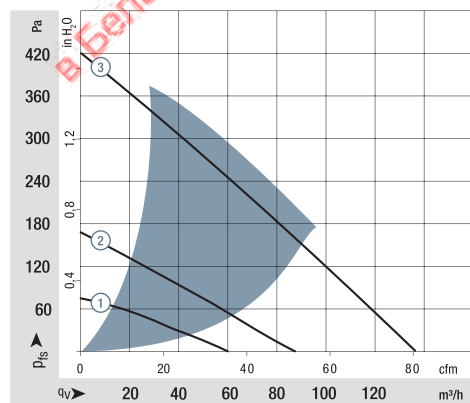

Air performance measured according to: ISO 5801.
Installation category A, without contact protection.
Noise: Total sound power level L_{WA} ISO 10302
measured on a hemisphere with a radius of 2 m.
Sound pressure level L_{pA} measured at 1 m distance
from fan axis.
The values given are applicable only under the specified
measuring conditions and may differ depending on the
installation conditions.
In the event of deviation from the standard configuration,
the parameters must be checked after installation!
For detailed information see
<http://www.ebmpapst.com/general conditions>

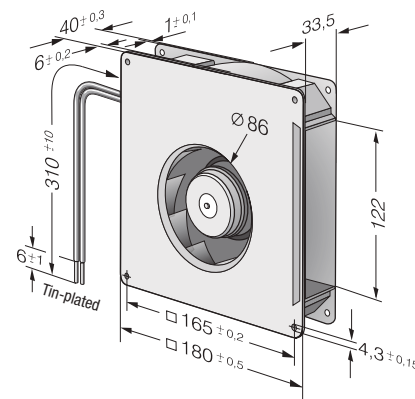

Max. 118 m³/h

DC centrifugal fans

□ 180 x 40 mm



- **Material:** Scroll housing: GRP¹⁾
Impeller: GRP¹⁾
Base plate: Sheet steel
 - **Direction of air flow:** Axial: Intake,
Centrifugal: Exhaust
 - **Connection:** via single wires AWG 22, TR 64
 - **Highlights:** Backward-curved impeller
3-phase fan drive with special commutation electronics for extremely low-noise operation
 - **Weight:** 750 g
- **Possible special versions:** (See chapter DC fans - specials)
 - Speed signal
 - Go / No-go alarm
 - Alarm with speed limit
 - External temperature sensor
 - PWM control input
 - Analog control input
 - Multi-option control input
 - Moisture protection
 - Salt spray protection
 - Degree of protection: IP 54

1) Fiberglass-reinforced plastic

Series RG 140 NTD
VCS0140XUJCS

Nominal data

Type	Air flow		Nominal voltage	Voltage range		Sound power level	Sinter sleeve bearings Ball bearings	Power consumption	Nominal speed	Temperature range	Service life L ₁₀ (40 °C) ebm-papst standard	Service life L ₁₀ (T max) ebm-papst standard	Life expectancy L ₁₀ IPC (40 °C) see page 15	Curve
	m ³ /h	cfm		VDC	VDC									
RG 140-22/12 N/2 TDAU-505	118	69.4	12	10.8...13.2	6.0	■	10.2	2 500	-20...+70	62 500 / 32 500	105 000	①		
RG 140-22/14 N/2 TDPU	118	69.4	24	20.4...27.6	6.0	■	9.3	2 500	-20...+70	62 500 / 32 500	105 000	①		

Subject to change

Higher performance levels on request.

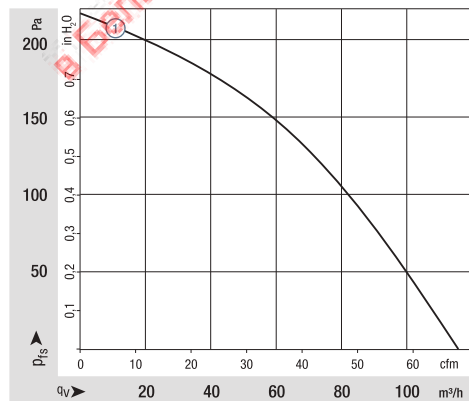

Air performance measured according to: ISO 5801.
Installation category A, without contact protection.
Noise: Total sound power level L_{WA} ISO 10302 measured on a hemisphere with a radius of 2 m.
Sound pressure level L_{pA} measured at 1 m distance from fan axis.
The values given are applicable only under the specified measuring conditions and may differ depending on the installation conditions.
In the event of deviation from the standard configuration, the parameters must be checked after installation!
For detailed information see <http://www.ebmpapst.com/general-conditions>

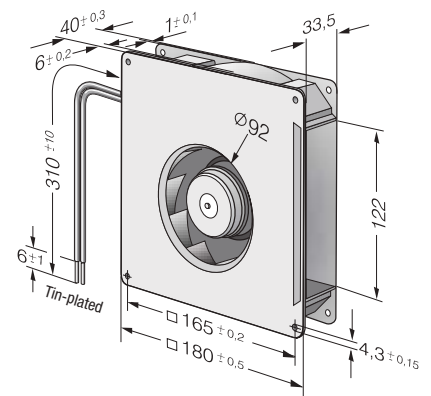

Max. 209 m³/h

DC centrifugal fans

□ 220 x 56 mm

Information

DC axial fans

DC centrifugal fans

DC fans - specials

ACmaxx / EC axial fans

AC axial fans

AC centrifugal fans

Accessories

Representatives



- **Material:** Scroll housing: GRP¹⁾
Impeller: GRP¹⁾
Base plate: Sheet steel
 - **Direction of air flow:** Axial: Intake,
Centrifugal: Exhaust
 - **Connection:** Via single wires AWG 22, TR 64
48 V model: Flat plug
6.3 x 0.8 mm for ground conductor
 - **Highlights:** Backward-curved impeller
 - **Weight:** 1.4 kg
- **Possible special versions:** (See chapter DC fans - specials)
 - Speed signal
 - Go / NoGo alarm
 - Alarm with speed limit
 - External temperature sensor
 - Internal temperature sensor
 - PWM control input
 - Analog control input
 - Moisture protection
 - Salt spray protection
 - Degree of protection: IP 54

1) Fiberglass-reinforced plastic

Series RG 160 N
VCS0160XULCS

Nominal data

Type	Air flow		Nominal voltage	Voltage range		Sound power level	Sintec sleeve bearings Ball bearings	Power consumption	Nominal speed	Temperature range	Service life L ₁₀ (40 °C) ebm-papst standard	Service life L ₁₀ (T _{max}) ebm-papst standard	Life expectancy L ₁₀ IPC (40 °C) see page 15	Curve
	m ³ /h	cfm		VDC	VDC									
RG 160-28/12 N	209	123	12	7.5...14	6.6	■	21.0	2 850	-20...+70	70 000 / 35 000	117 500	②		
RG 160-28/14 NM	139	81	24	12...28	5.6	■	7.0	1 900	-20...+70	80 000 / 40 000	135 000	①		
RG 160-28/14 N	209	123	24	12...28	6.6	■	20.0	2 850	-20...+70	70 000 / 35 000	117 500	②		
RG 160-28/18 N	209	123	48	28...60	6.6	■	20.0	2 850	-20...+70	70 000 / 35 000	117 500	②		

Subject to change

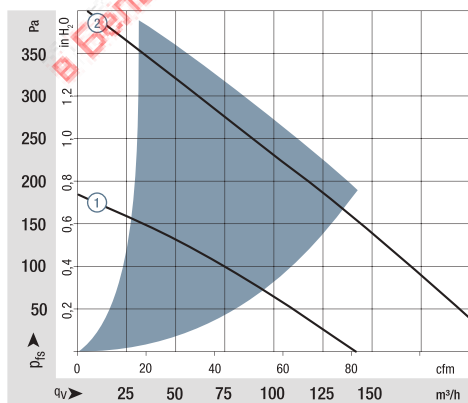

Air performance measured according to: ISO 5801.
Installation category A, without contact protection.
Noise: Total sound power level L_{WA} ISO 10302 measured on a hemisphere with a radius of 2 m.
Sound pressure level L_{pA} measured at 1 m distance from fan axis.
The values given are applicable only under the specified measuring conditions and may differ depending on the installation conditions.
In the event of deviation from the standard configuration, the parameters must be checked after installation!
For detailed information see
<http://www.ebmpapst.com/general-conditions>

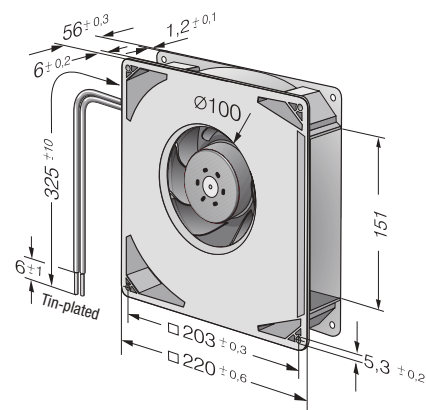

Max. 444 m³/h

DC centrifugal fans

□ 220 x 56 mm



- **Material:** Scroll housing: GRP¹⁾
Impeller: GRP¹⁾
Base plate: Sheet steel
- **Direction of air flow:** Axial: Intake,
Centrifugal: Exhaust
- **Connection:** Via single wires AWG 22, TR 64
48 V model: Flat plug
6.3 x 0.8 mm for ground conductor
- **Highlights:** Smoothly operating 3-phase fan drive
Backward-curved impeller
- **Weight:** 1.4 kg

- **Possible special versions:**
(See chapter DC fans - specials)
 - Speed signal
 - Go / NoGo alarm
 - Alarm with speed limit
 - External temperature sensor
 - Internal temperature sensor
 - PWM control input
 - Analog control input
 - Humidity protection
 - Degree of protection: IP 54

1) Fiberglass-reinforced plastic

Series RG 160 NTD
VCS0160YULCS

Nominal data

Type	Air flow		Nominal voltage		Voltage range	Sound power level	Sinter sleeve bearings Ball bearings	Power consumption	Nominal speed	Temperature range	Service life L ₁₀ (40 °C) ebm-papst standard	Service life L ₁₀ (T max) ebm-papst standard	Life expectancy L ₁₀ (IPC (40 °C) see page 15	Curve
	m ³ /h	cfm	VDC	VDC										
Min. Max. RG 160-28/14 NTD...	59	34.7	24	16...28	—	7.5	■	2.0	800	-20...+60	55 000 / 35 000	92 500	①	
	308	181												②
RG 160-28/14 NTD	308	181	24	16...28	7.5	■	64	4 200	-20...+60	55 000 / 35 000	92 500	②		
RG 160-28/14 NTDH	370	218	24	16...28	7.8	■	101	5 000	-20...+60	50 000 / 32 500	85 000	③		
Min. Max. RG 160-28/18 NTD...	59	34.7	48	38...57	—	7.5	■	2.0	800	-20...+70	55 000 / 27 500	92 500	①	
	308	181												②
RG 160-28/18 N/2 TDHHP*	444	261	48	36...60	8.5	■	159	6 000	-20...+65	40 000 / 22 500	67 500	④		

Subject to change

Models RG 160-28/14 NTD... and RG 160-28/18 NTD... are available in customer-specific, custom-developed variants only.
The figures indicated are technically feasible benchmark values.
The fans can be specially adapted to your application with signal outputs and control inputs.
*The specific service life is valid when an external capacitor is wired between the positive and negative wires.
Please note the wiring suggestion.

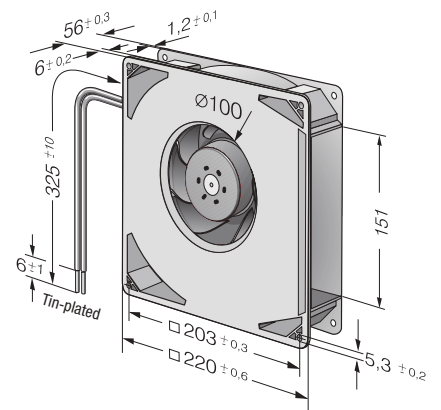
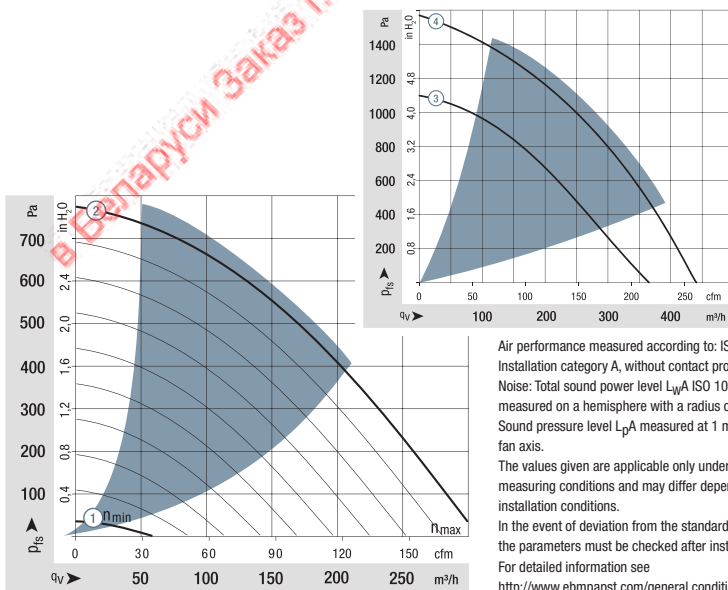

Max. 930 m³/h
S-Force

DC centrifugal fans – RadiCal

□ 226 x 85 mm



- **Material:** Scroll housing: GRP¹⁾
Impeller: GRP¹⁾
 - **Direction of air flow:** Axial: Intake,
Centrifugal: Exhaust
 - **Direction of rotation:** Clockwise, looking towards rotor
 - **Connection:** via single wires AWG 18, 20 or
AWG 22, TR 64. Speed signal
and control input AWG 22
 - **Highlights:** Highly efficient and smoothly
operating 3-phase fan drive
Backward-curved RadiCal
impeller
 - **Weight:** 1210 g
- **Possible special versions:**
(See chapter DC fans - specials)
 - Speed signal
 - Go / NoGo alarm
 - Alarm with speed limit
 - External temperature sensor
 - Internal temperature sensor
 - PWM control input
 - Analog control input
 - Multi-option control input
 - Moisture protection
 - Salt spray protection
 - Degree of protection: IP 54

1) Fiberglass-reinforced plastic

Series RG 190 TD
VCS0190RULDS

Nominal data

Type	Air flow		Nominal voltage	Voltage range		Sound power level	Sintec sleeve bearings Ball bearings	Power consumption	Nominal speed	Temperature range	Service life L ₁₀ (40 °C) ebm-papst standard	Service life L ₁₀ (T max) ebm-papst standard	Life expectancy L ₁₀ IPC (40 °C) see page 15	Curve
	m ³ /h	cfm		VDC	VDC									
RG 190-39/14/2 TDML0	630	371	24	16...30	7.3	■	55	3 000	-20...+60	55 000 / 35 000	92 500	①		
RG 190-39/14/2 TDM0	820	482	24	16...36	7.9	■	113	3 900	-20...+65	52 500 / 30 000	87 500	②		
RG 190-39/18/2 TDML0	630	371	48	36...57	7.3	■	58	3 000	-20...+60	55 000 / 35 000	92 500	①		
RG 190-39/18/2 TDM0	820	482	48	36...72	7.9	■	113	3 900	-20...+65	52 500 / 30 000	87 500	②		
RG 190-39/18/2 TD0	930	547	48	36...72	8.3	■	140	4 400	-20...+65	40 000 / 22 500	67 500	③		

Subject to change

Speed control range from 800 rpm⁻¹ at 7 % PWM up to nominal speed at > 90 % PWM. Standstill at 0 % PWM, Standstill if control cable is interrupted.

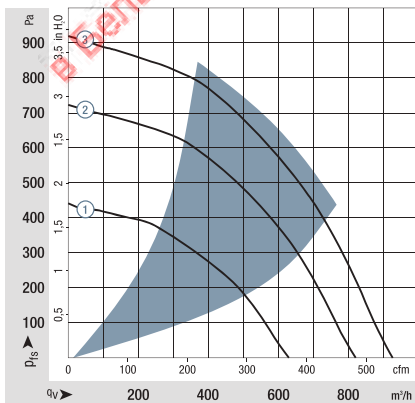

Air performance measured according to: ISO 5801.
Installation category A, without contact protection.
Noise: Total sound power level L_{WA} ISO 10302
measured on a hemisphere with a radius of 2 m.
Sound pressure level L_{pA} measured at 1 m distance
from fan axis.
The values given are applicable only under the specified
measuring conditions and may differ depending on the
installation conditions.
In the event of deviation from the standard configuration,
the parameters must be checked after installation!
For detailed information see
<http://www.ebmpapst.com/general conditions>

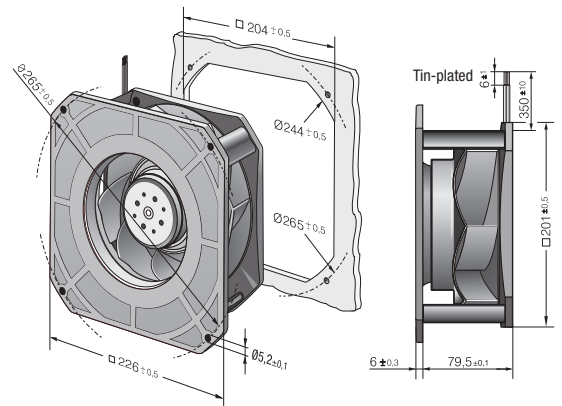

Max. 1100 m³/h
S-Force

DC centrifugal fans – RadiCal

□ 270 x 99 mm



- **Material:** Scroll housing: GRP¹⁾
Impeller: GRP¹⁾
 - **Direction of air flow:** Axial: Intake,
Centrifugal: Exhaust
 - **Direction of rotation:** Clockwise,
looking towards rotor
 - **Connection:** via single wires AWG 18, 20 or
AWG 22, TR 64. Speed signal
and control input AWG 22
 - **Highlights:** Highly efficient and smoothly
operating 3-phase fan drive
Backward-curved impeller
 - **Weight:** 1560 g
- **Possible special versions:**
(See chapter DC fans - specials)
 - Speed signal
 - Go / NoGo alarm
 - Alarm with speed limit
 - External temperature sensor
 - Internal temperature sensor
 - PWM control input
 - Analog control input
 - Humidity protection
 - Salt spray protection
 - Degree of protection: IP 54

1) Fiberglass-reinforced plastic

Series RG 220 TD
VCS0220RULDS

Nominal data

Type	Air flow		Nominal voltage	Voltage range		Sound power level	Sinter sleeve bearings Ball bearings	Power consumption	Nominal speed	Temperature range	Service life L ₁₀ (40 °C) ebm-papst standard	Service life L ₁₀ (T max) ebm-papst standard	Life expectancy L ₁₀ (IPC (40 °C) see page 15	Curve
	m ³ /h	cfm		VDC	VDC									
RG 220-43/14/2 TDMO	1100	647	24	16...36	7.5	■	101	3 000	-20...+55	55 000 / 40 000	92 500	①		
RG 220-43/18/2 TDMO*	1100	647	48	36...72	7.5	■	101	3 000	-20...+55	55 000 / 40 000	92 500	①		

Subject to change
* On request

Speed control range from 800 rpm⁻¹ at 7 % PWM up to nominal speed at > 90 % PWM.
Standstill at 0 % PWM, Standstill if control cable is interrupted.
Further types available on request.

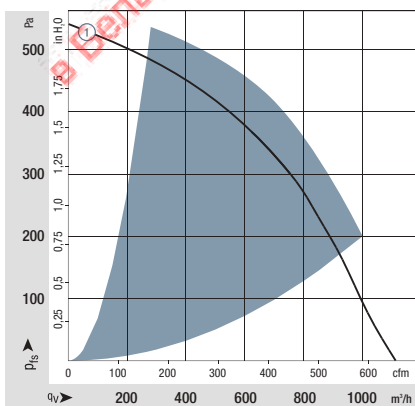

Air performance measured according to: ISO 5801.
Installation category A, without contact protection.
Noise: Total sound power level L_{WA} ISO 10302
measured on a hemisphere with a radius of 2 m.
Sound pressure level L_{pA} measured at 1 m distance
from fan axis.
The values given are applicable only under the specified
measuring conditions and may differ depending on the
installation conditions.
In the event of deviation from the standard configuration,
the parameters must be checked after installation!
For detailed information see
<http://www.ebmpapst.com/general-conditions>

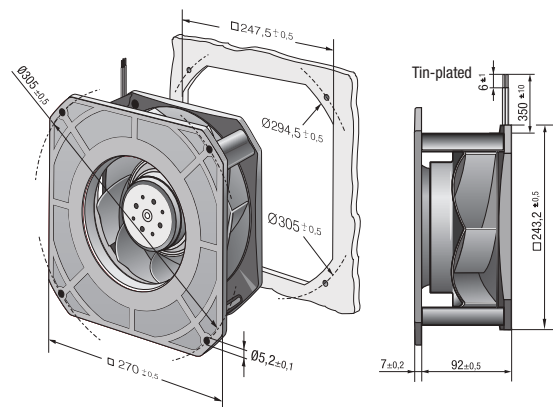

Max. 1450 m³/h
S-Force

DC centrifugal fans – RadiCal

□ 270 x 119 mm



- **Material:** Scroll housing: GRP¹⁾
Impeller: GRP¹⁾
 - **Direction of air flow:** Axial: Intake, Centrifugal: Exhaust
 - **Direction of rotation:** Clockwise, looking towards rotor
 - **Connection:** via single wires AWG 18, 20 or AWG 22, TR 64. Speed signal and control input AWG 22
 - **Highlights:** Highly efficient and smoothly operating 3-phase fan drive
Backward-curved RadiCal impeller
 - **Weight:** 1750 g
- **Possible special versions:** (See chapter DC fans - specials)
 - Speed signal
 - Go / NoGo alarm
 - Alarm with speed limit
 - External temperature sensor
 - Internal temperature sensor
 - PWM control input
 - Analog control input
 - Humidity protection
 - Salt spray protection
 - Degree of protection: IP 54

1) Fiberglass-reinforced plastic

Series RG 225 TD
VCS0225RULDS

Nominal data

Type	Air flow		Nominal voltage	Voltage range		Sound power level	Sinter sleeve bearings Ball bearings	Power consumption	Nominal speed	Temperature range	Service life L ₁₀ (40 °C) ebm-papst standard	Service life L ₁₀ (T _{max}) ebm-papst standard	Life expectancy L ₁₀ IPC (40 °C) see page 15	Curve
	m ³ /h	cfm		VDC	VDC									
RG 225-55/14/2 TDML0	1090	641	24	16...36	7.4	■	80	2 500	-20...+65	52 500 / 30 000	87 500	①		
RG 225-55/18/2 TDM0	1210	712	48	36...72	7.9	■	116	2 800	-20...+55	55 000 / 40 000	92 500	②		
RG 225-55/18/2 TDO	1450	853	48	36...60	8.1	■	192	3 300	-20...+40	30 000 / 30 000	50 000	③		

Subject to change

Speed control range from 800 rpm⁻¹ at 7 % PWM up to nominal speed at > 90 % PWM. Standstill at 0 % PWM, Standstill if control cable is interrupted.
The specific service life is valid when an external capacitor is wired between the positive and negative wires. Please note the wiring suggestion.

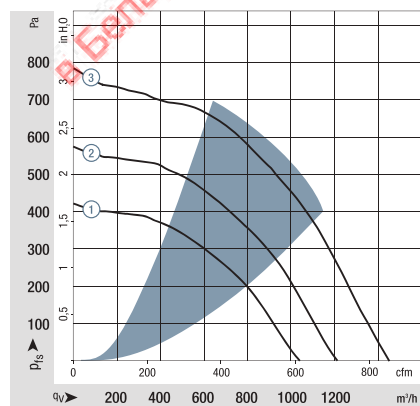

Air performance measured according to: ISO 5801.
Installation category A, without contact protection.
Noise: Total sound power level L_{WA} ISO 10302 measured on a hemisphere with a radius of 2 m.
Sound pressure level L_{pA} measured at 1 m distance from fan axis.
The values given are applicable only under the specified measuring conditions and may differ depending on the installation conditions.
In the event of deviation from the standard configuration, the parameters must be checked after installation!
For detailed information see http://www.ebmpapst.com/general_conditions

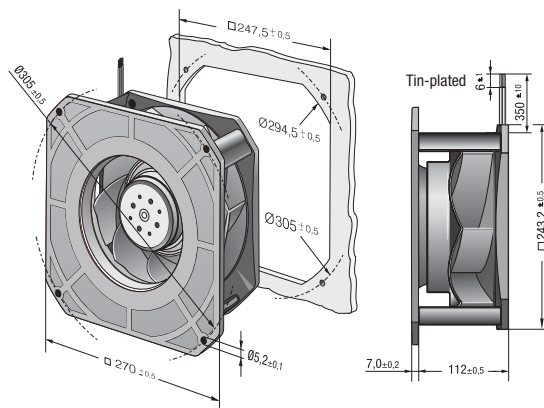

Max. 94 m³/h
S-Force

DC centrifugal fans

Ø 85 x 68 mm



- **Material:** Impeller: Galvanized sheet steel
 - **Direction of air flow:** Axial: Intake, Centrifugal: Exhaust
 - **Direction of rotation:** Clockwise, looking towards rotor
 - **Connection:** via single wires AWG 18, 20 or AWG 22, TR 64.
 - **Highlights:** 3-phase fan drive with special commutation electronic for extremely low-noise operation
Forwards-curved impeller
Fan requires a scroll housing
 - **Weight:** 450 g
- **Possible special versions:** (See chapter DC fans - specials)
 - Speed signal
 - Go / No-go alarm
 - Alarm with limit speed
 - External temperature sensor
 - PWM control input
 - Analogue control input
 - Multi-option control input (0)
 - Protection against moisture

Series RET 85 TD
VFS0085XUJCS

Nominal data

Type	Air flow		Nominal voltage	Voltage range	Sound power level	Sinter sleeve bearings Ball bearings	Power consumption	Nominal speed	Temperature range	Service life L ₁₀ (40 °C) ebm-papst standard	Service life L ₁₀ (T max) ebm-papst standard	Life expectancy L ₁₀ IPC (40 °C) see page 15	Curve
	m ³ /h	cfm											
RET 85-42/14/2 TDLOR-402	94	55	24	20...28	5.6	■	11.3	2 850	-20...+60	62 500 / 40 000		105 000	①

Subject to change

All nominal data were measured in the scroll housing.

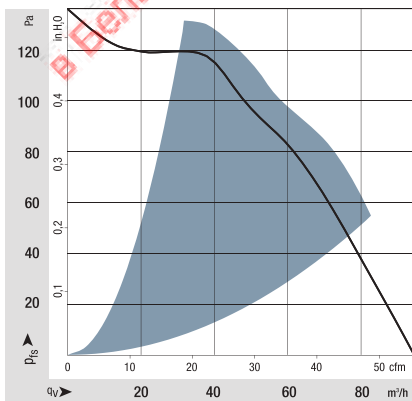

Air performance measured according to: ISO 5801.
Installation category A, without contact protection.
Noise: Total sound power level L_{WA} ISO 10302 measured on a hemisphere with a radius of 2 m.
Sound pressure level L_{pA} measured at 1 m distance from fan axis.
The values given are applicable only under the specified measuring conditions and may differ depending on the installation conditions.
In the event of deviation from the standard configuration, the parameters must be checked after installation!
For detailed information see
<http://www.ebmpapst.com/general-conditions>

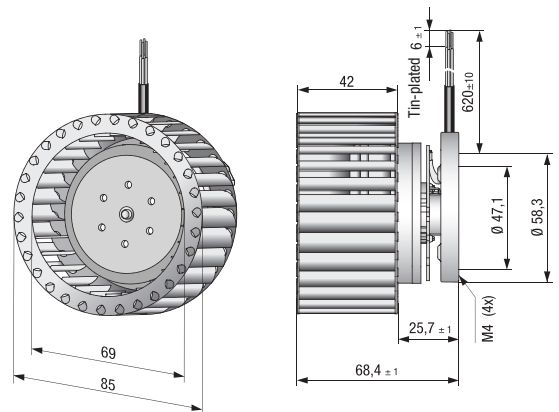

Max. 220 m³/h
S-Force

DC centrifugal fans

Ø 97 x 41 mm



- **Material:** Impeller: Galvanized sheet steel
 - **Direction of air flow:** Axial: Intake, Centrifugal: Exhaust
 - **Direction of rotation:** Clockwise, looking towards rotor
 - **Connection:** via single wires AWG 18, 20 or AWG 22, TR 64. Speed signal and control input AWG 22
 - **Highlights:** Highly efficient and smoothly operating 3-phase fan drive Forward-curved impeller Fan requires a scroll housing
 - **Weight:** 430 g
- **Possible special versions:** (See chapter DC fans - specials)
 - Speed signal
 - Go / NoGo alarm
 - Alarm with speed limit
 - External temperature sensor
 - Internal temperature sensor
 - PWM control input
 - Analog control input
 - Moisture protection

Series RET 97 TD
VFS0097XUJCS

Nominal data

Type	Air flow		Nominal voltage	Voltage range		Sound power level	Sinter sleeve bearings		Power consumption	Nominal speed	Temperature range	Service life L ₁₀ (40 °C) ebm-papst standard	Service life L ₁₀ (T max) ebm-papst standard	Life expectancy L ₁₀ IPC (40 °C) see page 15	Curve
	m ³ /h	cfm		VDC	VDC		Bel(A)	□ / ■							
RET 97-25/14/2 TDP	220	129	24	16...32	8.1	■	135	6 000	-20...+60	80 000 / 50 000	135 000	①			
RET 97-25/18/2 TDP	220	129	48	36...60	8.1	■	160	6 000	-20...+60	80 000 / 50 000	135 000	①			

Subject to change

Speed control range from 800 rpm⁻¹ at 7 % PWM up to nominal speed at > 90 % PWM.
Standstill at 0 % PWM, maximum speed if control cable is interrupted.
To attain the specified service life, an external capacitor must be wired between the positive and negative wires. Please note the wiring suggestion.
All nominal data were measured in the scroll housing.

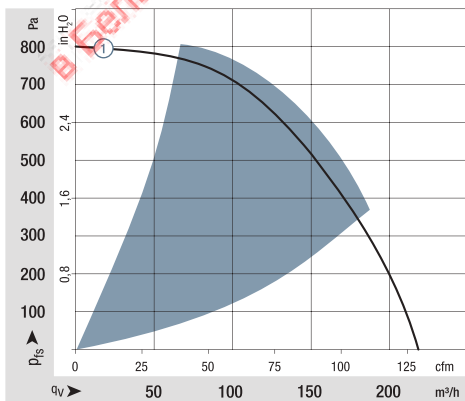

Air performance measured according to: ISO 5801.
Installation category A, with ebm-papst scroll housing without contact protection.
Noise: Total sound power level L_{WA} ISO 10302 measured on a hemisphere with a radius of 2 m.
Sound pressure level L_{PA} measured at 1 m distance from fan axis.
The values given are applicable only under the specified measuring conditions and may differ depending on the installation conditions.
In the event of deviation from the standard configuration, the parameters must be checked after installation!
For detailed information see <http://www.ebmpapst.com/general-conditions>

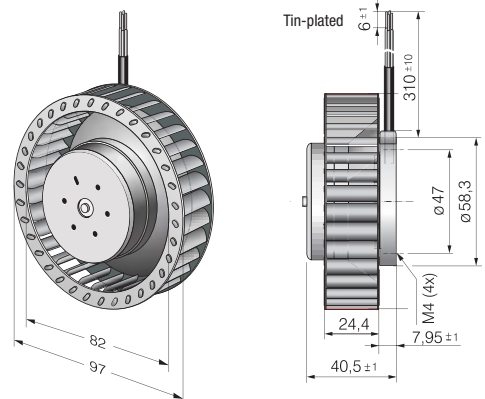

Max. 104 m³/h

DC centrifugal fans

Ø 104 x 25 mm



- **Material:** Impeller: GRP¹⁾
- **Direction of air flow:** Axial: Intake,
Centrifugal: Exhaust
- **Direction of rotation:** Clockwise,
looking towards rotor
- **Connection:** via single wires AWG 22, TR 64
- **Highlights:** Backward-curved impeller
- **Weight:** 160 g

- **Possible special versions:**
(See chapter DC fans - specials)
 - Speed signal
 - Go / NoGo alarm
 - Alarm with speed limit
 - External temperature sensor
 - Internal temperature sensor
 - PWM control input
 - Analog control input
 - Moisture protection
 - Degree of protection: IP 54

1) Fiberglass-reinforced plastic

Series REF 100
VBS0104XUGBS

Nominal data

Type	Air flow		Nominal voltage	Voltage range		Sound power level	Sintec sleeve bearings Ball bearings	Power consumption	Nominal speed	Temperature range	Service life L ₁₀ (40 °C) ebm-papst standard	Service life L ₁₀ (T _{max}) ebm-papst standard	Life expectancy L ₁₀ IPC (40 °C) see page 15	Curve
	m ³ /h	cfm		VDC	VDC									
REF 100-11/12	86	50.6	12	8...15	6.3	■	7.5	5 400	-20...+75	80 000 / 30 000	135 000	①		
REF 100-11/14	86	50.6	24	16...30	6.3	■	7.5	5 400	-20...+75	80 000 / 30 000	135 000	①		
REF 100-11/18/2	86	50.6	48	36...60	6.3	■	8.2	5 400	-20...+75	80 000 / 30 000	135 000	①		
REF 100-11/18 H	104	61.2	48	36...56	6.9	■	14.8	6 700	-20...+70	67 500 / 32 500	115 000	②		

Subject to change

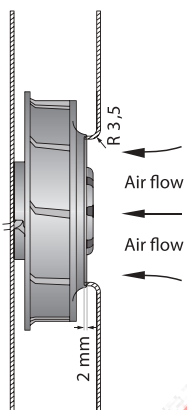

The air flow and sound level of the centrifugal fans without external housing depend on their individual installation conditions.

The stated air flow and sound level were recorded under the following measurement parameters:
Centrifugal fan mounted on a foundation plate 127 x 127 mm.
Cover plate 127 x 127 mm, with an air inlet opening Ø 70 mm, arranged concentrically to the impeller.

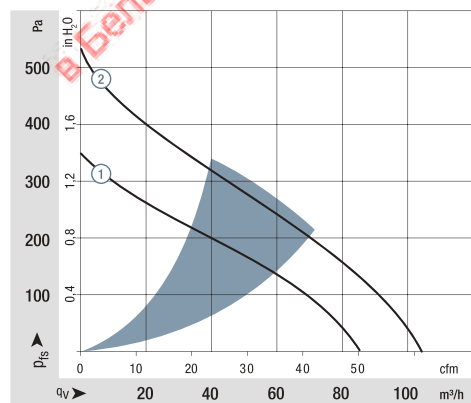

Air performance measured according to: ISO 5801.
Installation category A, with ebm-papst inlet ring without contact protection.
Noise: Total sound power level L_{WA} ISO 10302 measured on a hemisphere with a distance of 2 m;
Sound pressure level L_{pA} measured at 1 m distance from fan axis.
The values given are applicable only under the specified measuring conditions and may differ depending on the installation conditions.
In the event of deviation from the standard configuration, the parameters must be checked after installation!
For detailed information see <http://www.ebmpapst.com/general-conditions>

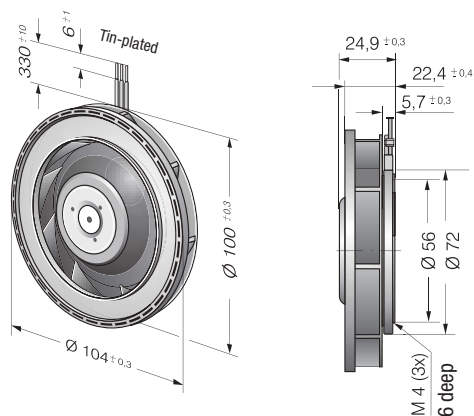

Max. 190 m³/h

DC centrifugal fans

Ø 101 x 52 mm



- **Material:** Impeller: GRP¹⁾
 - **Direction of air flow:** Axial: Intake, Centrifugal: Exhaust
 - **Direction of rotation:** Clockwise, looking towards rotor
 - **Connection:** via single wires AWG 22, TR 64
 - **Highlights:** Backward-curved impeller
 - **Weight:** 305 g
- **Possible special versions:** (See chapter DC fans - specials)
 - Speed signal
 - Go / NoGo alarm
 - Alarm with speed limit
 - External temperature sensor
 - Internal temperature sensor
 - PWM control input
 - Analog control input
 - Moisture protection

1) Fiberglass-reinforced plastic

Series RER 101 N
VBS0101XUGDS

Nominal data

Type	Air flow		Nominal voltage	Voltage range		Sound power level	Sinter sleeve bearings Ball bearings	Power consumption	Nominal speed	Temperature range	Service life L ₁₀ (40 °C) ebm-papst standard	Service life L ₁₀ (T max) ebm-papst standard	Life expectancy L ₁₀ (IPC (40 °C) see page 15	Curve
	m ³ /h	cfm		VDC	VDC									
RER 101-36/12 NH	162	95	12	9...13.6	6.9	■	13.0	5 000	-20...+70	65 000 / 32 500	110 000	②		
RER 101-36/12 NHH	190	112	12	9...13.6	7.2	■	20.5	6 000	-20...+70	60 000 / 30 000	102 500	①		
RER 101-36/14 NHH	190	112	24	18...27.2	7.2	■	22.5	6 050	-20...+70	60 000 / 30 000	102 500	①		
RER 101-36/18 NHH	190	112	48	36...60	7.2	■	19.4	5 850	-20...+70	60 000 / 30 000	102 500	①		

Subject to change

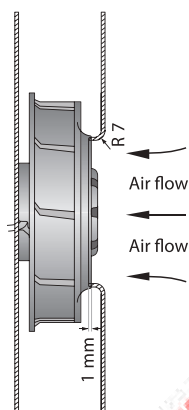

The air flow and sound level of the centrifugal fans without external housing depend on their individual installation conditions.

The stated air flow and sound level were recorded under the following measurement parameters:
Centrifugal fan mounted on a foundation plate 148 x 148 mm.
Cover plate 148 x 148 mm, with an air inlet opening Ø 66 mm, arranged concentrically to the impeller.

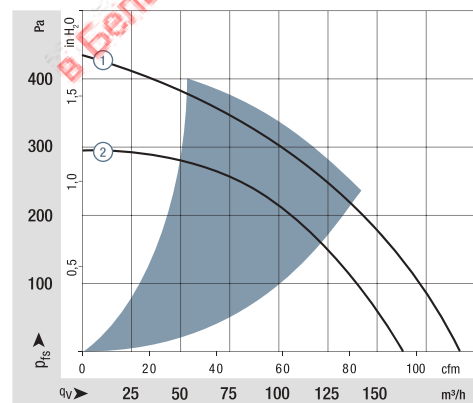

Air performance measured according to: ISO 5801.
Installation category A, with ebm-papst inlet ring without contact protection.
Noise: Total sound power level L_{WA} ISO 10302 measured on a hemisphere with a distance of 2 m; Sound pressure level L_{PA} measured at 1 m distance from fan axis.
The values given are applicable only under the specified measuring conditions and may differ depending on the installation conditions.
In the event of deviation from the standard configuration, the parameters must be checked after installation!
For detailed information see <http://www.ebmpapst.com/general-conditions>

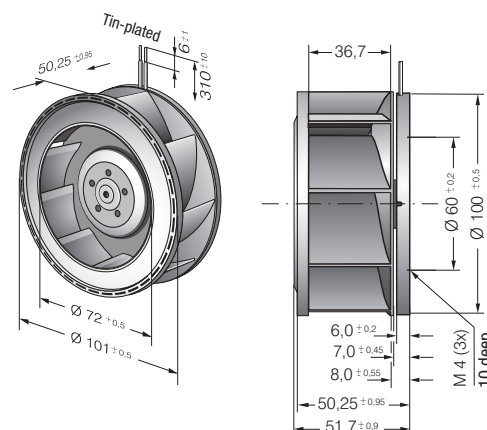

Max. 390 m³/h
S-Force

DC centrifugal fans

Ø 120 x 54 mm



- **Material:** Impeller: GRP¹⁾
- **Direction of air flow:** Axial: Intake,
Centrifugal: Exhaust
- **Direction of rotation:** Clockwise,
looking towards rotor
- **Connection:** via single wires AWG 18, 20 or
AWG 22, TR 64. Speed signal
and control input AWG 22
- **Highlights:** Highly efficient and smoothly
operating 3-phase fan drive
Backward-curved impeller
- **Weight:** 430 g

1) Fiberglass-reinforced plastic

Series RER 120 TD
VBS0120XUJCS

Nominal data	Air flow		Nominal voltage	Voltage range		Sound power level	Sinter sleeve bearings Ball bearings	Power consumption	Nominal speed	Temperature range	Service life L ₁₀ (40 °C) ebm-papst standard	Service life L ₁₀ (T max) ebm-papst standard	Life expectancy L ₁₀ IPC (40 °C) see page 15	Curve
	m ³ /h	cfm		VDC	VDC									
RER 120-26/14/2 TDP	377	222	24	16...32	8.2	■	78	6 100	-20...+60	55 000 / 35 000	92 500	②		
RER 120-26/18/2 TDMP	320	188	48	36...60	7.8	■	51	5 200	-20...+60	57 500 / 35 000	97 500	①		
RER 120-26/18/2 TDP	390	230	48	36...60	8.3	■	92	6 300	-20...+60	50 000 / 30 000	85 000	③		

Subject to change

Speed control range from 800 rpm⁻¹ at 7 % PWM up to nominal speed at > 90 % PWM. Standstill at 0 % PWM, maximum speed if control cable is interrupted.

The specific service life is valid when an external capacitor is wired between the positive and negative wires. Please note the wiring suggestion.

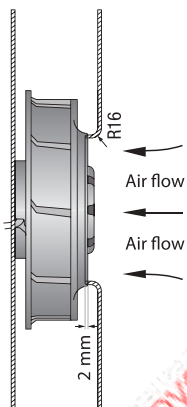

The air flow and sound level of the centrifugal fans without external housing depend on their individual installation conditions.

The stated air flow and sound level were recorded under the following measurement parameters:
Centrifugal fan mounted on a foundation plate
142 x 142 mm.
Cover plate 142 x 142 mm, with an air inlet opening
Ø 94.4 mm, arranged concentrically to the impeller.

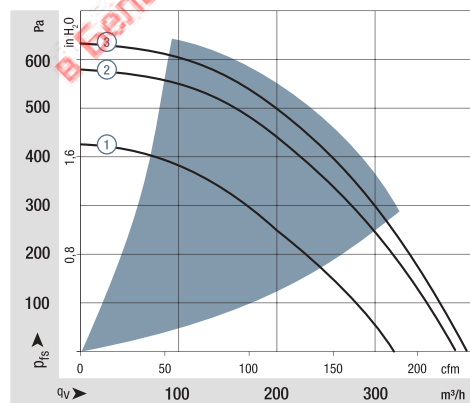

Air performance measured according to: ISO 5801.
Installation category A, with ebm-papst inlet ring without contact protection.
Noise: Total sound power level L_{WA} ISO 10302 measured on a hemisphere with a distance of 2 m;
Sound pressure level L_{pA} measured at 1 m distance from fan axis.
The values given are applicable only under the specified measuring conditions and may differ depending on the installation conditions.
In the event of deviation from the standard configuration, the parameters must be checked after installation!
For detailed information see
<http://www.ebmpapst.com/general-conditions>

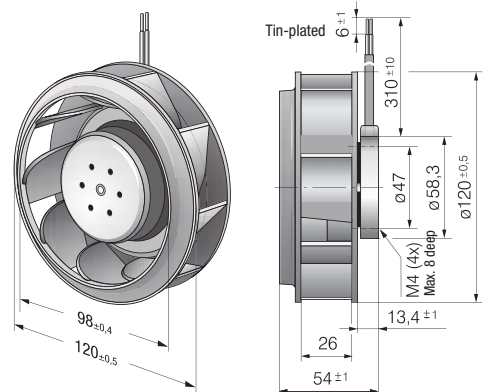

Max. 250 m³/h

DC centrifugal fans

Ø 120 mm



- **Material:** Impeller: PA 6.6 plastic, fiberglass-reinforced
Rotor: Galvanized
- **Number of blades:** 9
- **Direction of rotation:** Clockwise, looking towards rotor
- **Degree of protection:** IP 20
- **Insulation class:** "B"
- **Installation position:** Any
- **Condensation drainage holes:** None
- **Mode of operation:** Continuous operation (S1)
- **Bearings:** Maintenance-free ball bearings

VBS0120XUJCS

Nominal data

Type	Motor	Curve	Nominal voltage VDC	Nominal voltage range VDC	Air flow m ³ /h	Nominal speed rpm ⁻¹	Power consumption W	Input current A	Sound pressure level dB(A)	Admissible amb. temp. °C	Technical features and connection diagram
R1G 120	M1G 045-BE	Ⓐ	24	16-28	250	4060	26	1.20	62	-25..+50	p. 274 / G)

Subject to change

Curves:

U_N = nominal voltage
(24 V / 48 V)

U_R = over-voltage
(28 V / 57 V)

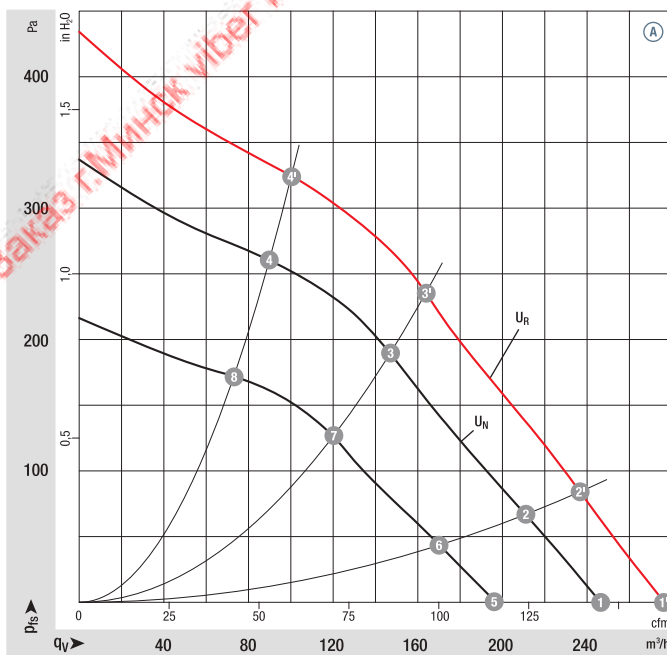

	n rpm ⁻¹	P _{ed} W	L _{pA} dB(A)	η _{IL} %
Ⓐ 1'	4520	36	65	—
Ⓐ 2'	4500	36	64	27
Ⓐ 3'	4540	36	61	45
Ⓐ 4'	4750	32	64	39
Ⓐ 1	4060	26	62	—
Ⓐ 2	4000	26	61	27
Ⓐ 3	4050	26	58	45
Ⓐ 4	4200	23	61	39
Ⓐ 5	3270	14	56	—
Ⓐ 6	3250	14	55	27
Ⓐ 7	3280	14	53	45
Ⓐ 8	3400	13	56	39

Air performance measured according to: ISO 5801, installation category A, with ebm-papst inlet ring without contact protection. Suction-side noise levels: LWA according to ISO 13347, L_{pA} measured at 1 m distance from fan axis. The values given are applicable only under the specified measuring conditions and may differ depending on the installation conditions. In the event of deviation from the standard configuration, the parameters must be checked after installation! For detailed information see <http://www.ebmpapst.com/general-conditions>

- **Technical features:** See connection diagram p. 274
- **Cable exit:** Axial
- **Conformity with standard(s):** EN 60950-1
- **Approvals:** EAC

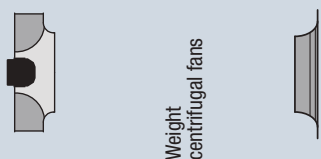

Weight
centrifugal fans

Centrifugal fans	kg	Inlet ring (long)
R1G 120-AD13 -02	0.5	96120-2-4013

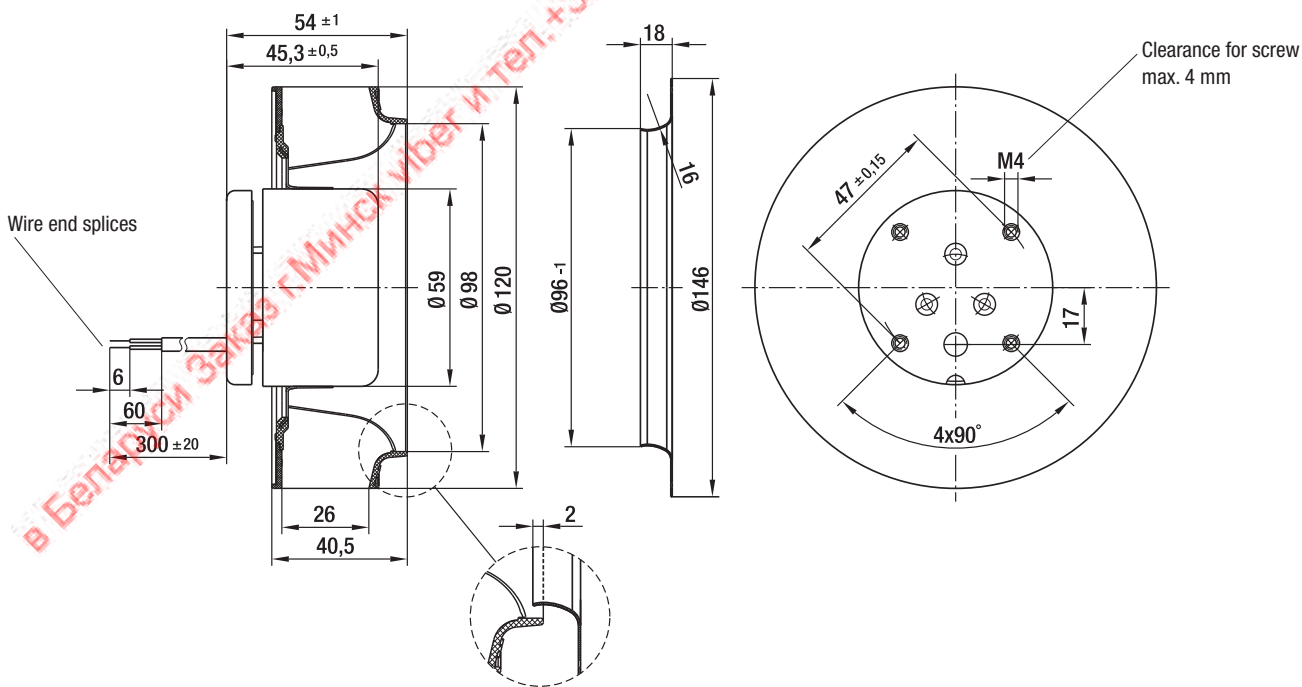

Max. 166 m³/h

DC centrifugal fans

Ø 138 x 35 mm



- **Material:** Impeller: GRP¹⁾
 - **Direction of air flow:** Axial: Intake, Centrifugal: Exhaust
 - **Direction of rotation:** Clockwise, looking towards rotor
 - **Connection:** via single wires AWG 22, TR 64
 - **Highlights:** Backward-curved impeller
 - **Weight:** 320 g
- **Possible special versions:** (See chapter DC fans - specials)
 - Speed signal
 - Go / NoGo alarm
 - Alarm with speed limit
 - External temperature sensor
 - Internal temperature sensor
 - PWM control input
 - Analog control input
 - Moisture protection
 - Salt spray protection
 - Degree of protection: IP 54 / IP 68

1) Fiberglass-reinforced plastic

Series RER 125 N
VBS0125XUJBS

Nominal data

Type	Air flow		Nominal voltage	Voltage range		Sound power level	Sinter sleeve bearings Ball bearings	Power consumption	Nominal speed	Temperature range	Service life L ₁₀ (40 °C) ebm-papst standard	Service life L ₁₀ (T max) ebm-papst standard	Life expectancy L ₁₀ IPC (40 °C) see page 15	Curve
	m ³ /h	cfm		VDC	VDC									
RER 125-19/12 N	110	64.7	12	7...15	5.7	■	4.6	2 650	-30...+75	62 500 / 27 500	105 000	①		
RER 125-19/14 N	110	64.7	24	12...28	5.7	■	4.3	2 650	-30...+75	62 500 / 27 500	105 000	①		
RER 125-19/14 NH-172	166	97.7	24	12...28	7.0	■	13.0	4 000	-20...+70	55 000 / 27 500	92 500	②		
RER 125-19/18 N	110	64.7	48	36...56	5.7	■	4.2	2 650	-30...+75	62 500 / 27 500	105 000	①		

Subject to change

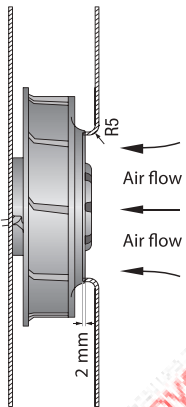

The air flow and sound level of the centrifugal fans without external housing depend on their individual installation conditions.

The stated air flow and sound level were recorded under the following measurement parameters:
Centrifugal fan mounted on a foundation plate 220 x 220 mm.
Cover plate 220 x 220 mm, with an air inlet opening Ø 86 mm, arranged concentrically to the impeller.

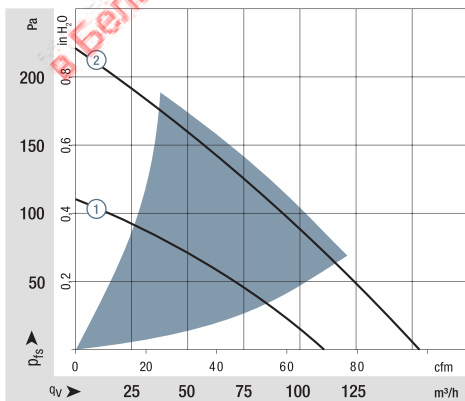

Air performance measured according to: ISO 5801.
Installation category A, with ebm-papst inlet ring without contact protection.
Noise: Total sound power level L_{wA} ISO 10302 measured on a hemisphere with a distance of 2 m; Sound pressure level L_{pA} measured at 1 m distance from fan axis.
The values given are applicable only under the specified measuring conditions and may differ depending on the installation conditions.
In the event of deviation from the standard configuration, the parameters must be checked after installation!
For detailed information see <http://www.ebmpapst.com/general conditions>

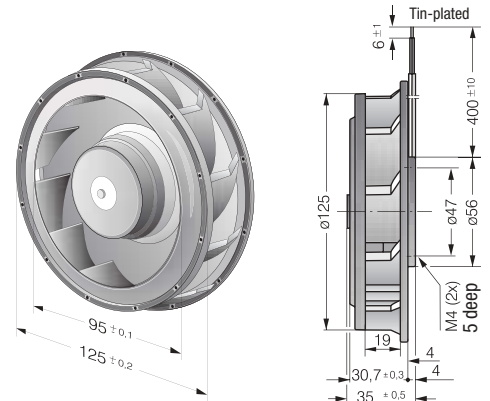

Max. 565 m³/h
S-Force

DC centrifugal fans

Ø 133 x 91 mm



- **Material:** Impeller: GRP¹⁾
 - **Direction of air flow:** Axial: Intake, Centrifugal: Exhaust
 - **Direction of rotation:** Clockwise, looking towards rotor
 - **Connection:** via single wires AWG 18, 20 or AWG 22, TR 64. Speed signal and control input AWG 22
 - **Highlights:** Highly efficient and smoothly operating 3-phase fan drive Backward-curved impeller
 - **Weight:** 890 g
460 g RadiCal
- **Possible special versions:** (See chapter DC fans - specials)
 - Speed signal
 - Go / NoGo alarm
 - Alarm with speed limit
 - External temperature sensor
 - Internal temperature sensor
 - PWM control input
 - Analog control input
 - Multi-option control input
 - Moisture protection
 - Salt spray protection
 - Degree of protection: IP 54

1) Fiberglass-reinforced plastic

Series RER 133 TD
VBS0133XULDS
VBS0133RUJCS

Nominal data

Type	Air flow		Nominal voltage	Voltage range		Sound power level	Sintec sleeve bearings Ball bearings	Power consumption	Nominal speed	Temperature range	Service life L ₁₀ (40 °C) ebm-papst standard	Service life L ₁₀ (1 max) ebm-papst standard	Life expectancy L ₁₀ IPC (40 °C) see page 15	Curve
	m ³ /h	cfm		VDC	VDC									
RER 133-41/14/2 TDMP	460	271	24	16...30	7.8	■	58	5 000	-20...+65	72 500 / 40 000	122 500	①		
RER 133-41/14/2 TDP	565	332	24	16...36	8.2	■	90	6 000	-20...+65	70 000 / 37 500	117 500	②		
RER 133-41/18/2 TDP	565	332	48	36...72	8.2	■	87	6 000	-20...+65	70 000 / 37 500	117 500	②		
RadiCal RER 133-33/18/2 TDMO	395	232	48	36...60	7.7	■	62	5 600	-20...+65	55 000 / 30 000	92 500	③		

Subject to change

Speed control range from 800 rpm⁻¹ at 7 % PWM up to nominal speed at > 90 % PWM.
Standstill at 0 % PWM, maximum speed if control cable is interrupted.

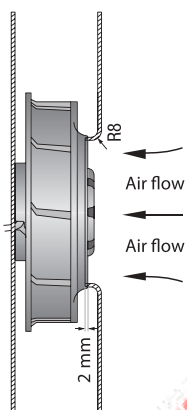

The air flow and sound level of the centrifugal fans without external housing depend on their individual installation conditions.
The stated air flow and sound level were recorded under the following measurement parameters:
Centrifugal fan mounted on a foundation plate
157 x 157 mm.
Cover plate 157 x 157 mm, with an air inlet opening Ø 87 mm, arranged concentrically to the impeller.

RER 133 TD RadiCal

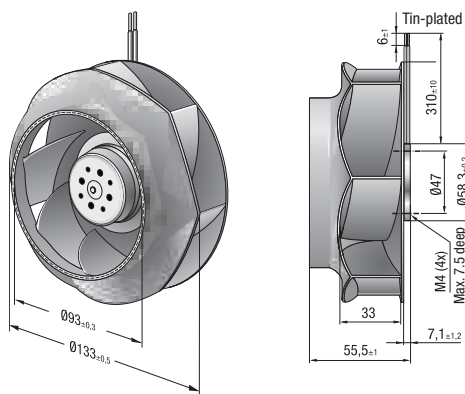

RER 133 TD

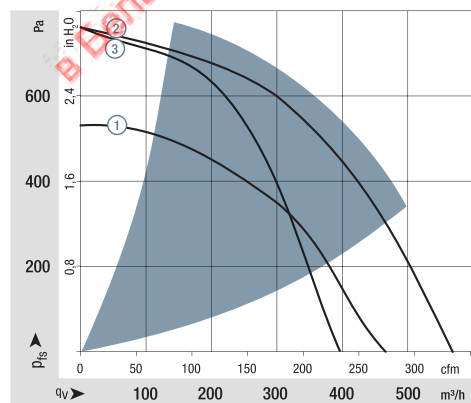
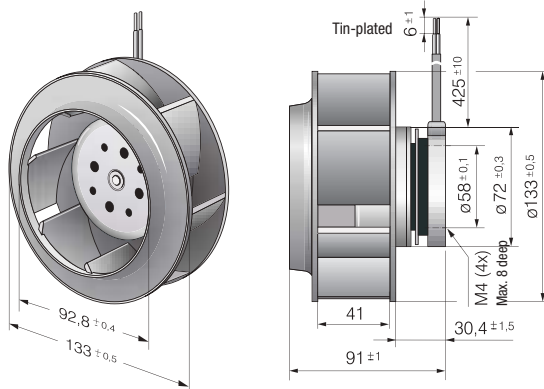

Air performance measured according to: ISO 5801. Installation category A, with ebm-papst inlet ring without contact protection.
Noise: Total sound power level L_{WA} ISO 10302 measured on a hemisphere with a distance of 2 m;
Sound pressure level L_{pA} measured at 1 m distance from fan axis.
The values given are applicable only under the specified measuring conditions and may differ depending on the installation conditions.
In the event of deviation from the standard configuration, the parameters must be checked after installation!
For detailed information see <http://www.ebmpapst.com/general conditions>

max. 225 m³/h

DC centrifugal fans

Ø 140 x 36 mm



- **Material:** Impeller: GRP¹⁾
 - **Direction of air flow:** Axial: Intake
Centrifugal: Exhaust
 - **Direction of rotation:** Clockwise, seen on rotor
 - **Connection:** Via single wires AWG 22, TR 64
 - **Highlights:** Backwards-curved impeller
3-phase fan drive with special commutation electronic for extremely low-noise operation
 - **Mass:** 360 g
- **Possible special versions:**
 - Go / No-go alarm
 - Alarm with limit speed
 - External temperature sensor
 - Analogue control input
 - Multi-option control input
 - Protection against moisture
 - Protection against salt fog
 - Type of protection: IP 54

1) Fibreglass-reinforced plastic

Series RER 140 TD
VBS0140XUJCS

Nominal data

Type	Air flow		Nominal voltage	Voltage range	Sound power level	Sinter sleeve bearings Ball bearings	Power consumption	Nominal speed	Temperature range	Service life L ₁₀ (40 °C) ebm-papst standard	Service life L ₁₀ (T max) ebm-papst standard	Life expectancy L ₁₀ (IPC (40 °C) see page 15	Curve
	m ³ /h	cfm											
RER 140-22/14 N/2TDP	225	132	24	20...28	6.9	■ / ■	34	3 850	-20...+65	55 000 / 30 000		92 500	①

Subject to change

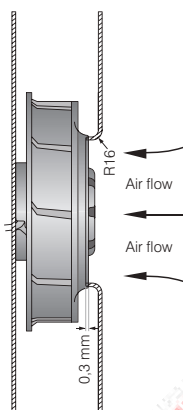

The air flow and sound level of the centrifugal fans without external housing depend on their individual installation conditions.

The stated air flow and sound level were recorded under the following measurement parameters:
Centrifugal fan mounted on a foundation plate 166 x 166 mm.
Cover plate 166 x 166 mm, with an air inlet opening Ø 94.4 mm, arranged concentrically to the impeller.

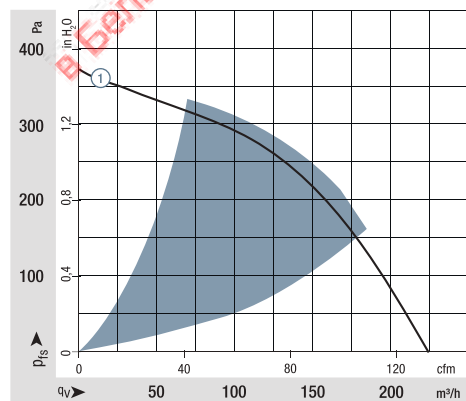

Air performance measured according to: ISO 5801.
Installation category A, with ebm-papst inlet ring without contact protection.
Noise: Total sound power level L_{WA} ISO 10302 measured on a hemisphere with a distance of 2 m;
Sound pressure level L_{PA} measured at 1 m distance from fan axis.
The values given are applicable only under the specified measuring conditions and may differ depending on the installation conditions.
In the event of deviation from the standard configuration, the parameters must be checked after installation!
For detailed information see <http://www.ebmpapst.com/general-conditions>

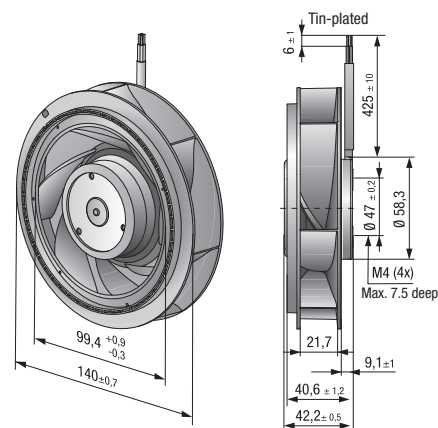

Max. 255 m³/h

DC centrifugal fans

Ø 165 x 51 mm



- **Material:** Impeller: GRP¹⁾
 - **Direction of air flow:** Axial: Intake, Centrifugal: Exhaust
 - **Direction of rotation:** Counterclockwise, looking towards rotor
 - **Connection:** via single wires AWG 22, TR 64
 - **Highlights:** Backward-curved impeller
 - **Weight:** 590 g
- **Possible special versions:** (See chapter DC fans - specials)
 - Speed signal
 - Go / NoGo alarm
 - Alarm with speed limit
 - External temperature sensor
 - Internal temperature sensor
 - PWM control input
 - Analog control input
 - Moisture protection
 - Salt spray protection
 - Degree of protection: IP 54

1) Fiberglass-reinforced plastic

Series RER 160 N
VBS0160XULCS

Nominal data

Type	Air flow		Nominal voltage	Voltage range		Sound power level	Sintec sleeve bearings Ball bearings	Power consumption	Nominal speed	Temperature range	Service life L ₁₀ (40 °C) ebm-papst standard	Service life L ₁₀ (T max) ebm-papst standard	Life expectancy L ₁₀ (IPC (40 °C) see page 15	Curve
	m ³ /h	cfm		VDC	VDC									
RER 160-28/12 N	270	158.8	12	7.5...14	6.4	■	19.0	3 000	-20...+70	75 000 / 37 500	127 500	①		
RER 160-28/14 N	270	158.8	24	12...28	6.4	■	19.0	3 000	-20...+70	75 000 / 37 500	127 500	①		
RER 160-28/18 N*	270	158.8	48	28...60	6.4	■	19.0	3 000	-20...+70	75 000 / 37 500	127 500	①		

Subject to change
* On request

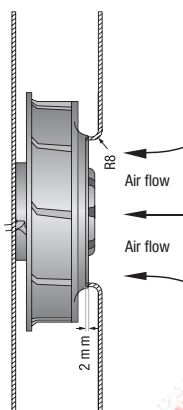

The air flow and sound level of the centrifugal fans without external housing depend on their individual installation conditions.
The stated air flow and sound level were recorded under the following measurement parameters:
Centrifugal fan mounted on a foundation plate 266 x 266 mm.
Cover plate 266 x 266 mm, with an air inlet opening Ø 100 mm, arranged concentrically to the impeller.

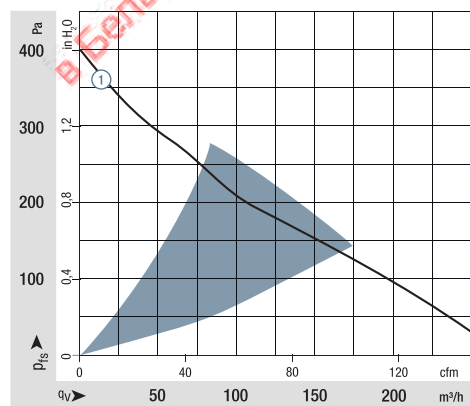

Air performance measured according to: ISO 5801.
Installation category A, with ebm-papst inlet ring without contact protection.
Noise: Total sound power level L_{WA} ISO 10302 measured on a hemisphere with a distance of 2 m; Sound pressure level L_{pA} measured at 1 m distance from fan axis.
The values given are applicable only under the specified measuring conditions and may differ depending on the installation conditions.
In the event of deviation from the standard configuration, the parameters must be checked after installation!
For detailed information see <http://www.ebmpapst.com/general-conditions>

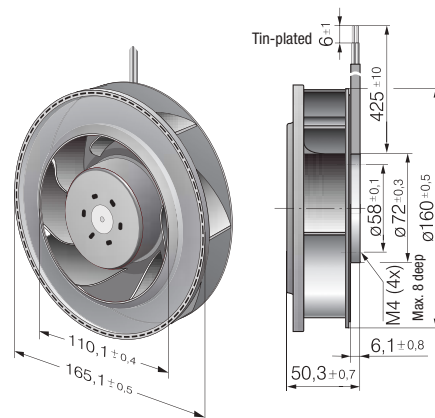

Max. 360 m³/h
S-Force

DC centrifugal fans

Ø 165 x 51 mm



- **Material:** Impeller: GRP¹⁾
 - **Direction of air flow:** Axial: Intake, Centrifugal: Exhaust
 - **Direction of rotation:** Clockwise, looking towards rotor
 - **Connection:** via single wires AWG 22, TR 64
 - **Highlights:** Highly efficient and smoothly operating 3-phase fan drive
Backward-curved impeller
 - **Weight:** 590 g
- **Possible special versions:**
(See chapter DC fans - specials)
 - Speed signal
 - Go / NoGo alarm
 - Alarm with speed limit
 - External temperature sensor
 - Internal temperature sensor
 - PWM control input
 - Analog control input
 - Humidity protection
 - Degree of protection: IP 54

1) Fiberglass-reinforced plastic

Series RER 160 NTD
VBS0160XULCS

Nominal data	Air flow		Nominal voltage	Voltage range	Sound power level	Sinter sleeve bearings Ball bearings	Power consumption	Nominal speed	Temperature range	Service life L ₁₀ (40 °C) ebm-papst standard	Service life L ₁₀ (T _{max}) ebm-papst standard	Life expectancy L ₁₀ IPC (40 °C) see page 15	Curve
	m ³ /h	cfm											
RER 160-28/14 NTD...	360	211	24	16...28	7.4	■	51	4 200	-20...+60	55 000 / 27 500	92 500	②	
RER 160-28/18 NTD...	360	211	48	38...57	7.4	■	48	4 200	-20...+70	55 000 / 27 500	92 500	①	

Subject to change

Model RER 160-28/18 NTD... is available in customer-specific, custom-developed variant only.

The figures indicated are technically feasible benchmark values. The fans can be specially adapted to your application with signal outputs and control inputs.

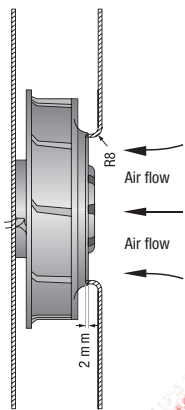

The air flow and sound level of the centrifugal fans without external housing depend on their individual installation conditions.

The stated air flow and sound level were recorded under the following measurement parameters:
Centrifugal fan mounted on a foundation plate 266 x 266 mm.
Cover plate 266 x 266 mm, with an air inlet opening Ø 100 mm, arranged concentrically to the impeller.

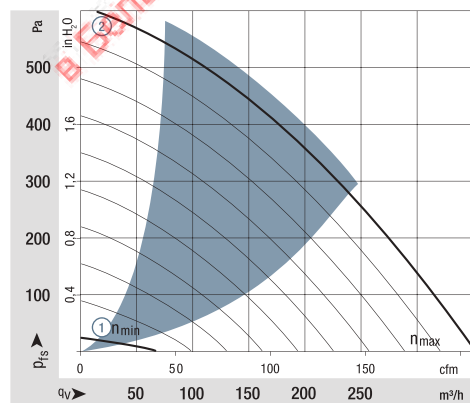

Air performance measured according to: ISO 5801.
Installation category A, with ebm-papst inlet ring without contact protection.
Noise: Total sound power level L_{WA} ISO 10302 measured on a hemisphere with a distance of 2 m;
Sound pressure level L_{pA} measured at 1 m distance from fan axis.
The values given are applicable only under the specified measuring conditions and may differ depending on the installation conditions.
In the event of deviation from the standard configuration, the parameters must be checked after installation!
For detailed information see <http://www.ebmpapst.com/general-conditions>

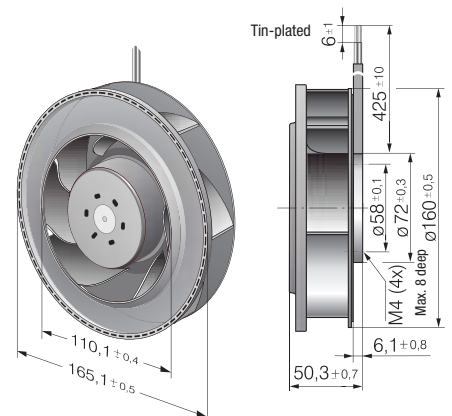

Max. 800 m³/h
S-Force

DC centrifugal fans

Ø 175 x 55 mm



- **Material:** Impeller: Galvanized sheet steel
 - **Direction of air flow:** Axial: Intake, Centrifugal: Exhaust
 - **Direction of rotation:** Clockwise, looking towards rotor
 - **Connection:** via single wires AWG 18, 20 or AWG 22, TR 64. Speed signal and control input AWG 22
 - **Highlights:** Highly efficient and smoothly operating 3-phase fan drive Backward-curved impeller
 - **Weight:** 930 g
- **Possible special versions:** (See chapter DC fans - specials)
 - Speed signal
 - Go / NoGo alarm
 - Alarm with speed limit
 - External temperature sensor
 - Internal temperature sensor
 - PWM control input
 - Analog control input
 - Multi-option control input
 - Humidity protection
 - Degree of protection: IP 54

Series RER 175 TD
VBS0175XULDS

Nominal data

Type	Air flow		Nominal voltage	Voltage range		Sound power level	Sintec sleeve bearings Ball bearings	Power consumption	Nominal speed	Temperature range	Service life L ₁₀ (40 °C) ebm-papst standard	Service life L ₁₀ (T max) ebm-papst standard	Life expectancy L ₁₀ (IPC (40 °C) see page 15	Curve
	m ³ /h	cfm		VDC	VDC									
REF 175-30/18/2 DP	800	470	48	36 ... 72	8.3	■	154	4 400	-20...+60	65 000 / 37 500	110 000	①		

Subject to change

Speed control range from 800 rpm⁻¹ at 7 % PWM up to nominal speed at > 90 % PWM.
Standstill at 0 % PWM, maximum speed if control cable is interrupted.

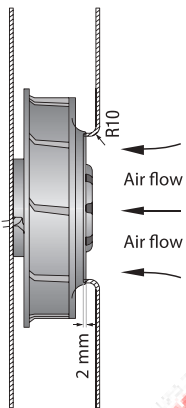

The air flow and sound level of the centrifugal fans without external housing depend on their individual installation conditions. The stated air flow and sound level were recorded under the following measurement parameters:
Centrifugal fan mounted on a foundation plate 207 x 207 mm.
Cover plate 207 x 207 mm, with an air inlet opening Ø 125.5 mm, arranged concentrically to the impeller.

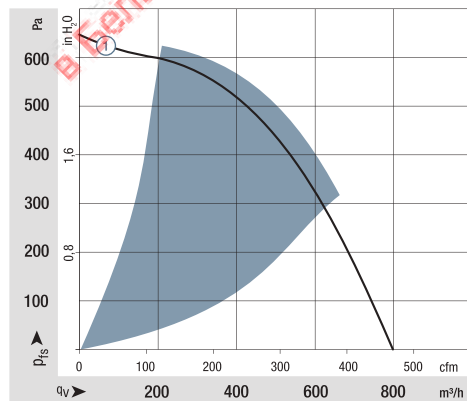

Air performance measured according to: ISO 5801.
Installation category A, with ebm-papst inlet ring without contact protection.
Noise: Total sound power level L_{WA} ISO 10302 measured on a hemisphere with a distance of 2 m;
Sound pressure level L_{pA} measured at 1 m distance from fan axis.
The values given are applicable only under the specified measuring conditions and may differ depending on the installation conditions.
In the event of deviation from the standard configuration, the parameters must be checked after installation!
For detailed information see <http://www.ebmpapst.com/general-conditions>

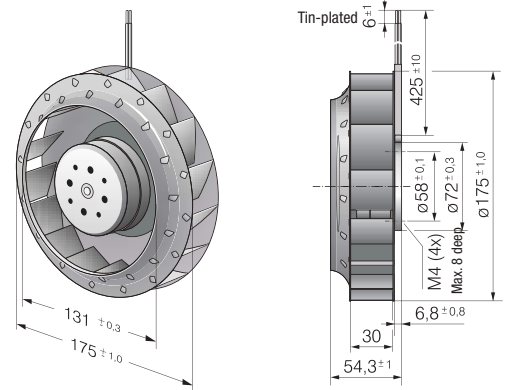

Max. 980 m³/h
S-Force

DC centrifugal fans

Ø 175 x 69 mm



- **Material:** Impeller: GRP¹⁾
 - **Direction of air flow:** Axial: Intake, Centrifugal: Exhaust
 - **Direction of rotation:** Clockwise, looking towards rotor
 - **Connection:** Via single wires AWG 18, 20 or AWG 22, TR 64, speed signal and control input AWG 22
 - **Highlights:** Highly efficient and smoothly operating 3-phase fan drive Backward-curved impeller
 - **Weight:** 775 g
- Possible special versions:**
(See chapter DC fans - specials)
- Speed signal
 - Go / NoGo alarm
 - Alarm with speed limit
 - External temperature sensor
 - Internal temperature sensor
 - PWM control input
 - Analog control input
 - Multi-option control input
 - Moisture protection
 - Salt spray protection
 - Degree of protection: IP 54

1) Fiberglass-reinforced plastic

Series RER 175 TD
VBS0175XULCS
VBS0175RULDS

Nominal data

Type	Air flow		Nominal voltage	Voltage range		Sound power level	Sintec sleeve bearings Ball bearings	Power consumption	Nominal speed	Temperature range	Service life L ₁₀ (40 °C) ebm-papst-standard	Service life L ₁₀ (1 max) ebm-papst-standard	Life expectancy L ₁₀ IPC (40 °C) see page 15	Curve
	m ³ /h	cfm		VDC	VDC									
RER 175-42/14/2 TDMLP	600	353	24	16...30	7.3	■	48	3 400	-20...+65	72 500 / 40 000	122 500	①		
RER 175-42/14/2 TDMP	865	509	24	16...36	8.2	■	110	4 800	-20...+65	70 000 / 40 000	117 500	②		
RER 175-42/18/2 TDMLP	600	353	48	36...57	7.3	■	46	3 400	-20...+65	72 500 / 40 000	122 500	①		
RER 175-42/18/2 TDMP	865	509	48	36...72	8.2	■	110	4 800	-20...+65	70 000 / 40 000	117 500	②		
RER 175-42/18/2 TDP	980	577	48	36...72	8.5	■	166	5 400	-20...+65	60 000 / 32 500	102 500	③		
RadiCal RER 175-39/18/2 TDPR-113	948	556	48	36...72	8.4	■	178	5 400	-20...+65	72 500 / 40 000	122 500	④		

Subject to change

Speed control range from 800 rpm⁻¹ at 7 % PWM up to nominal speed at > 90 % PWM.
Standstill at 0 % PWM, maximum speed if control cable is interrupted.

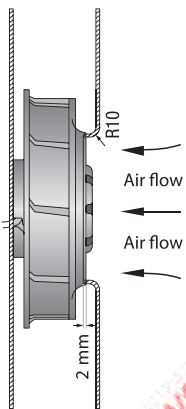

The air flow and sound level of the centrifugal fans without external housing depend on their individual installation conditions.

The stated air flow and sound level were recorded under the following measurement parameters:
Centrifugal fan mounted on a foundation plate 207 x 207 mm.
Cover plate 207 x 207 mm, with an air inlet opening Ø 125.5 mm, arranged concentrically to the impeller.

RadiCal RER 175-39/18/2 TDPR-113

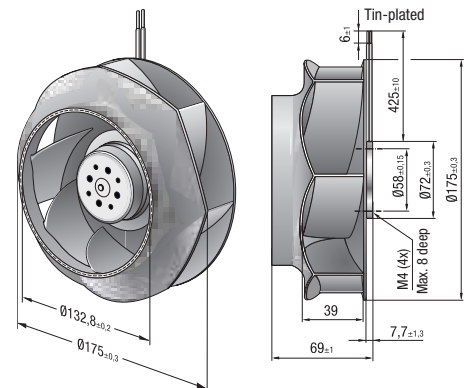

RER 175 TD

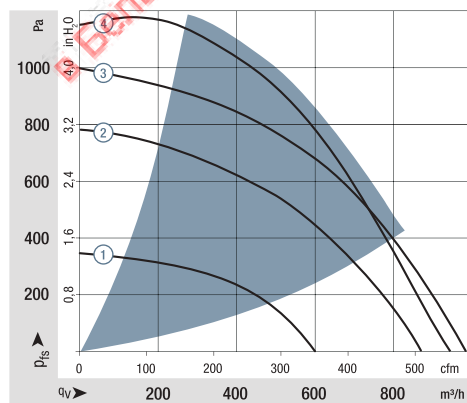
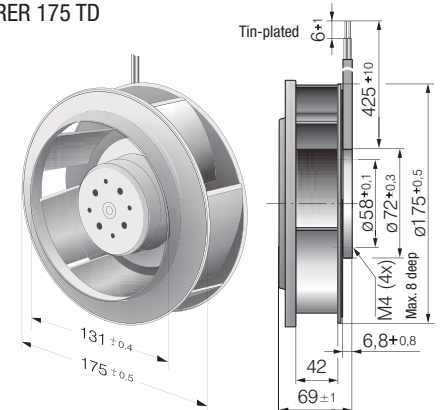

Air performance measured according to: ISO 5801.
Installation category A, with ebm-papst inlet ring without contact protection.
Noise: Total sound power level L_{WA} ISO 10302 measured on a hemisphere with a distance of 2 m;
Sound pressure level L_{pA} measured at 1 m distance from fan axis.
The values given are applicable only under the specified measuring conditions and may differ depending on the installation conditions.
In the event of deviation from the standard configuration, the parameters must be checked after installation!
For detailed information see <http://www.ebmpapst.com/general-conditions>

Max. 970 m³/h
S-Force

DC centrifugal fans – RadiCal

Ø 190 x 69 mm



- **Material:** Impeller: GRP¹⁾
 - **Direction of air flow:** Axial: Intake, Centrifugal: Exhaust
 - **Direction of rotation:** Clockwise, looking towards rotor
 - **Connection:** Via single wires AWG 18, 20 or AWG 22, TR 64, speed signal and control input AWG 22
 - **Highlights:** Highly efficient and smoothly operating 3-phase fan drive Backward-curved RadiCal impeller
 - **Weight:** 870 g
- **Possible special versions:** (See chapter DC fans - specials)
 - Speed signal
 - Go / NoGo alarm
 - Alarm with speed limit
 - External temperature sensor
 - Internal temperature sensor
 - PWM control input
 - Analog control input
 - Multi-option control input
 - Moisture protection
 - Salt spray protection
 - Degree of protection: IP 54

1) Fiberglass-reinforced plastic

Series RER 190 TD
VBS0190RULCS
VBS0190RULDS

Nominal data

Type	Air flow		Nominal voltage	Voltage range		Sound power level	Sintec sleeve bearings Ball bearings	Power consumption	Nominal speed	Temperature range	Service life L ₁₀ (40 °C) ebm-papst standard	Service life L ₁₀ (T max) ebm-papst standard	Life expectancy L ₁₀ (IPC (40 °C) see page 15	Curve
	m ³ /h	cfm		VDC	VDC									
RER 190-39/14/2 TDML0	650	382	24	16...30	7.6	■	58	3 000	-20...+60	55 000 / 35 000	92 500	①		
RER 190-39/14/2 TDM0	860	506	24	16...36	7.9	■	110	3 900	-20...+65	52 500 / 30 000	87 500	②		
RER 190-39/18/2 TDML0	650	382	48	36...57	7.6	■	56	3 000	-20...+65	55 000 / 30 000	92 500	①		
RER 190-39/18/2 TDMOR-211	860	506	48	36...72	7.9	■	105	3 900	-20...+65	52 500 / 30 000	87 500	②		
RER 190-39/18/2 TD0	970	571	48	36...72	8.3	■	148	4 400	-20...+65	40 000 / 22 500	67 500	③		

Subject to change

Speed control range from 800 rpm⁻¹ at 7 % PWM up to nominal speed at > 90 % PWM.
Standstill at 0 % PWM, Standstill if control cable is interrupted.

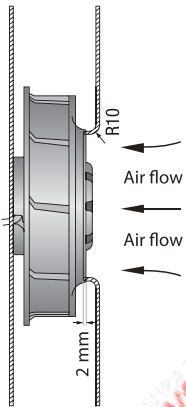

The air flow and sound level of the centrifugal fans without external housing depend on their individual installation conditions.
The stated air flow and sound level were recorded under the following measurement parameters:
Centrifugal fan mounted on a foundation plate 225 x 225 mm.
Cover plate 225 x 225 mm, with an air inlet opening Ø 125.5 mm, arranged concentrically to the impeller.

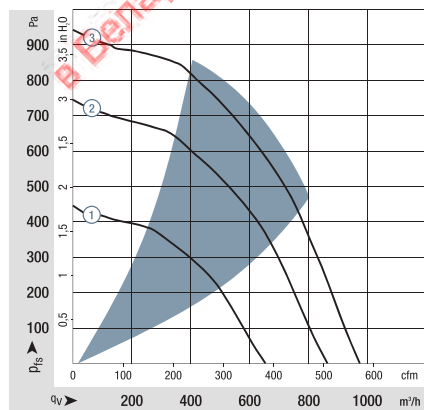

Air performance measured according to: ISO 5801.
Installation category A, with ebm-papst inlet ring without contact protection.
Noise: Total sound power level L_{WA} ISO 10302 measured on a hemisphere with a distance of 2 m;
Sound pressure level L_{pA} measured at 1 m distance from fan axis.
The values given are applicable only under the specified measuring conditions and may differ depending on the installation conditions.
In the event of deviation from the standard configuration, the parameters must be checked after installation!
For detailed information see
<http://www.ebmpapst.com/general conditions>

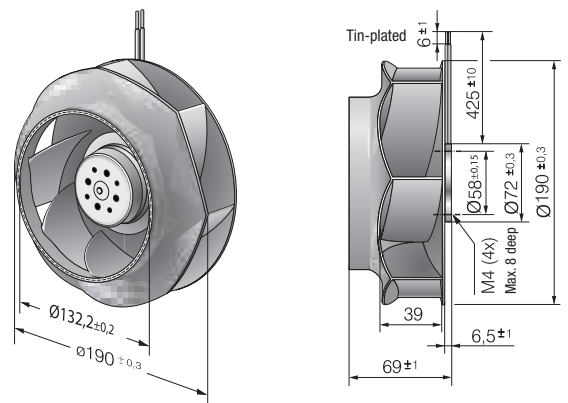

Max. 820 m³/h

EC centrifugal fans – RadiCal

Ø 190 mm



- **Material:** Impeller: PA plastic
Rotor: Galvanized
- **Number of blades:** 7
- **Direction of rotation:** Clockwise, looking towards rotor
- **Degree of protection:** Motor IP24 KM, electronics IP6K9K (mating connector installed)
- **Insulation class:** "B"
- **Installation position:** Shaft horizontal or rotor on bottom; rotor on top on request
- **Condensation drainage holes:** On rotor side
- **Mode of operation:** Continuous operation (S1)
- **Bearings:** Ball bearing; (sealed)

VBS0190RUNC5

Nominal data

Type	Motor	Curve	Nominal voltage		Air flow	Nominal speed	Power consumption	Input current	Admissible amb. temp.	Technical features and connection diagram
			VDC	VDC						
R1G 190	M1G074-BF	Ⓐ	12	8...16	565	3300	74	6.40	-25...+70	p. 278 / Q)
R1G 190	M1G074-BF	Ⓑ	24	16...28	755	4200	135	5.60	-25...+60	p. 278 / Q)
R1G 190	M1G074-BF	Ⓒ	48	36...57	820	4500	165	3.40	-25...+70	p. 279 / R)

Subject to change

Curves:

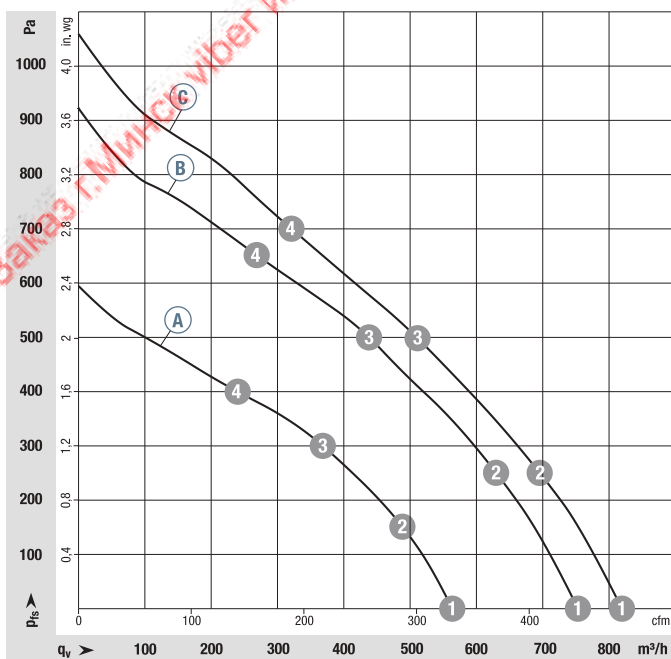

	n	P _{ed}	I
	rpm ⁻¹	W	A
Ⓐ 1	3300	74	6.40
Ⓐ 2	3245	78	6.71
Ⓐ 3	3175	80	7.05
Ⓐ 4	3250	78	6.72
Ⓑ 1	4200	135	5.60
Ⓑ 2	4080	142	5.90
Ⓑ 3	3985	147	6.12
Ⓑ 4	4115	140	5.83
Ⓒ 1	4500	165	3.40
Ⓒ 2	4380	165	3.40
Ⓒ 3	4215	167	3.50
Ⓒ 4	4345	165	3.40

Air performance measured according to: ISO 5801, installation category A, with ebm-papst inlet ring without contact protection. Suction-side noise levels: LWA according to ISO 13347, L_{pA} measured at 1 m distance from fan axis. The values given are applicable only under the specified measuring conditions and may differ depending on the installation conditions. In the event of deviation from the standard configuration, the parameters must be checked after installation! For detailed information see <http://www.ebmpapst.com/general-conditions>

- **Technical features:** See connection diagram p. 278/279
- **Cable exit:** Axial
- **Approvals:** EAC; CSA C22.2 No. 113; UL 507



Weight centrifugal fans



Centrifugal fans	kg	Inlet ring
R1G 190-RD61-02	1.45	09576-2-4013
R1G 190-RD79-02	1.46	09576-2-4013
R1G 190-RD16-02	1.30	09576-2-4013

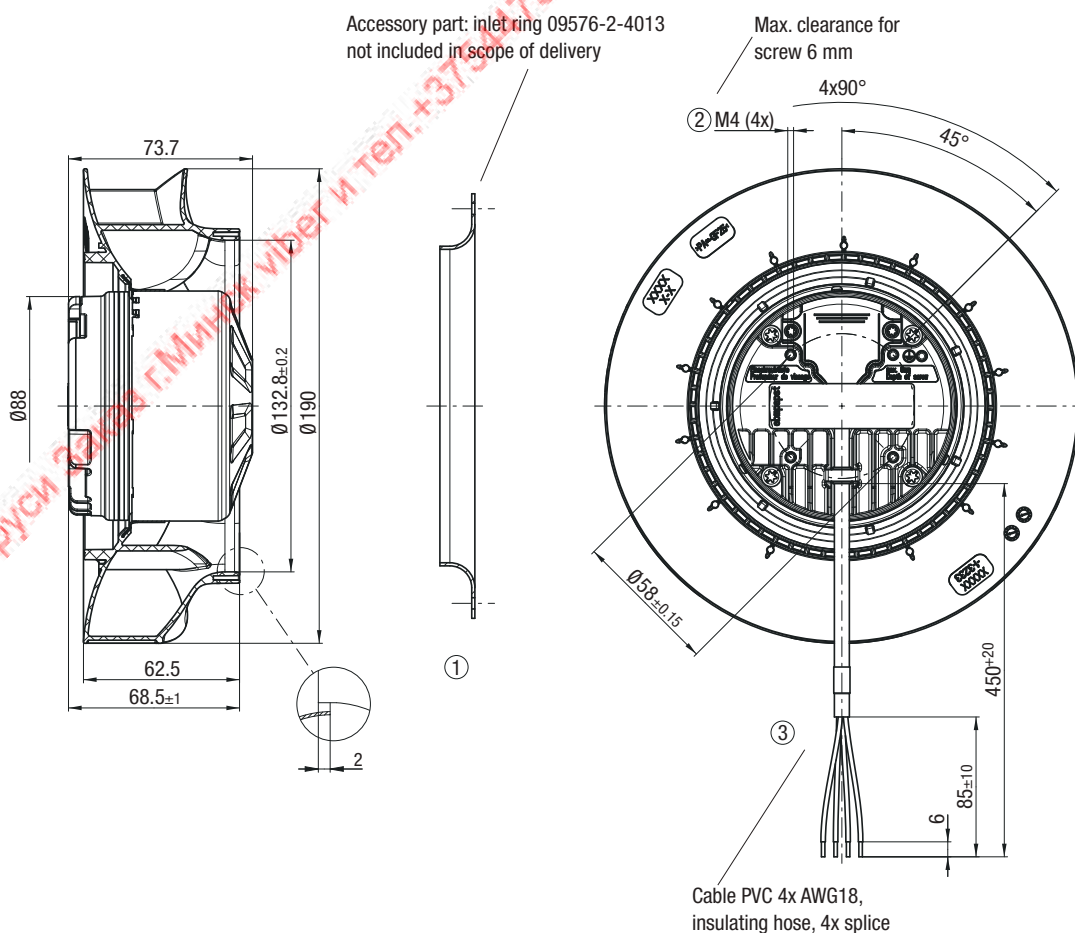

Max. 930 m³/h

DC centrifugal fans – RadiCal

Ø 190 mm

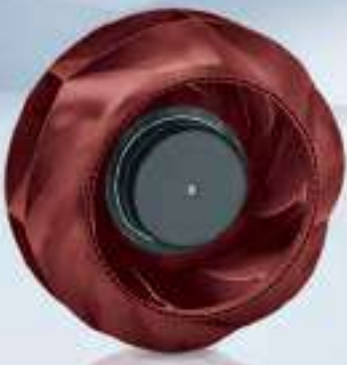

- **Material:** Impeller: PA plastic
Rotor: Painted black
- **Number of blades:** 7
- **Direction of rotation:** Clockwise, looking towards rotor
- **Degree of protection:** IP 44, depending on installation and position
- **Insulation class:** "B"
- **Installation position:** Any
- **Condensation drainage holes:** None
- **Mode of operation:** Continuous operation (S1)
- **Bearings:** Maintenance-free ball bearings

VBS0190RUNES

Nominal data

Type	Motor	Curve	Nominal voltage		Air flow	Nominal speed	Power consumption	Input current	Sound pressure level	Admissible amb. temp.	Technical features and connection diagram
			VDC	VDC							
R3G 190	M3G 074-CF	Ⓐ	24	16-28	880	4570	180	7.50	76	-25..+60	p. 277 / J5)
R3G 190	M3G 074-CF	Ⓑ	48	36-57	930	4800	192	4.00	76	-25..+60	p. 277 / J5)

Subject to change

Curves:

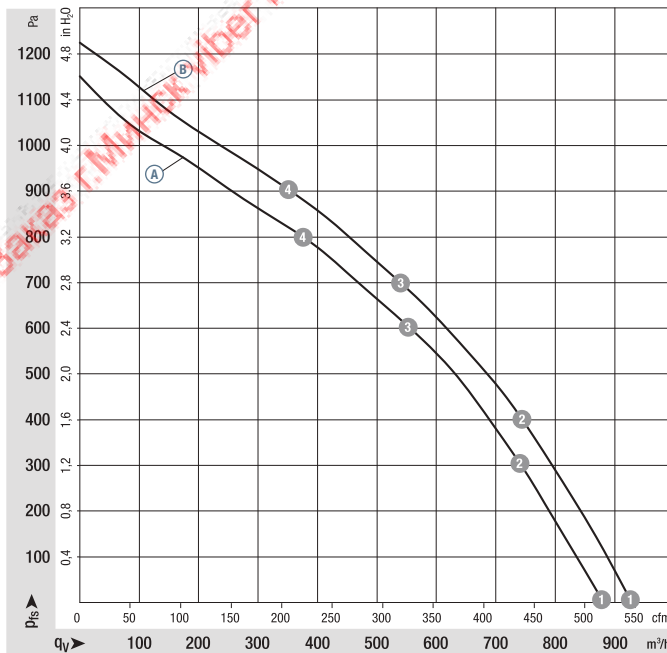

	n	P _{ed}	I	L _{WA}
	rpm ⁻¹	W	A	dB(A)
Ⓐ 1	4570	180	7.50	84
Ⓐ 2	4525	188	7.83	79
Ⓐ 3	4435	199	8.34	77
Ⓐ 4	4520	191	7.96	81
Ⓑ 1	4800	192	4.00	84
Ⓑ 2	4690	212	4.41	80
Ⓑ 3	4640	221	4.60	79
Ⓑ 4	4740	205	4.28	81

Air performance measured according to: ISO 5801, Installation category A, with ebm-papst inlet ring without contact protection. Suction-side noise levels: LWA according to ISO 13347, L_{vA} measured at 1 m distance from fan axis. The values given are applicable only under the specified measuring conditions and may differ depending on the installation conditions. In the event of deviation from the standard configuration, the parameters must be checked after installation! For detailed information see <http://www.ebmpapst.com/general-conditions>

- **Technical features:** See connection diagram p. 277
- **Cable exit:** Variable
- **Conformity with standard(s):** EN 60950-1
- **Approvals:** EAC



Weight centrifugal fans



Centrifugal fans	kg	Inlet ring
R3G 190-RN38 -01	1.9	09576-2-4013
R3G 190-RN99 -02	1.9	09576-2-4013

Accessory part: Inlet ring 09576-2-4013 not included in the standard scope of delivery

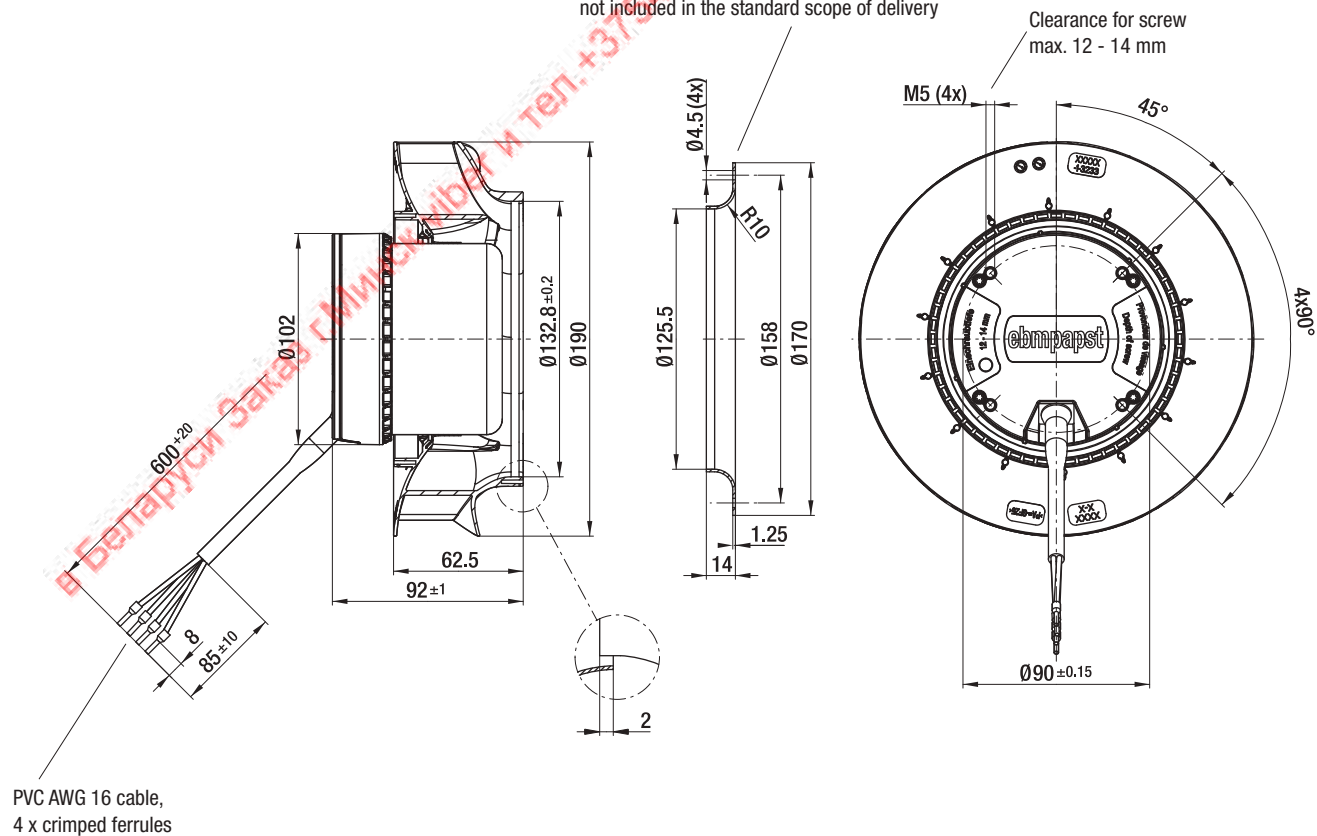

Max. 1080 m³/h

EC centrifugal fans – RadiCal

Ø 220 mm



- **Material:** Impeller: PA plastic
Rotor: Galvanized
- **Number of blades:** 7
- **Direction of rotation:** Clockwise, looking towards rotor
- **Degree of protection:** Motor IP24 KM, electronics IP6K9K (mating connector installed)
- **Insulation class:** "B"
- **Installation position:** Shaft horizontal or rotor on bottom; rotor on top on request
- **Condensation drainage holes:** On rotor side
- **Mode of operation:** Continuous operation (S1)
- **Bearings:** Ball bearing; (sealed)

VDS0220RUNCS

Nominal data

Type	Motor	Curve	Nominal voltage		Air flow	Nominal speed	Power consumption	Input current	Admissible amb. temp.	Technical features and connection diagram
			VDC	VDC						
R1G 220	M1G074-BF	Ⓐ	12	8...16	925	2700	90	8.60	-25...+70	p. 278 / Q)
R1G 220	M1G074-BF	Ⓑ	24	16...28	1070	3050	125	5.20	-25...+60	p. 278 / Q)
R1G 220	M1G074-BF	Ⓒ	48	36...57	1080	3150	125	2.60	-25...+70	p. 279 / R)

Subject to change

Curves:

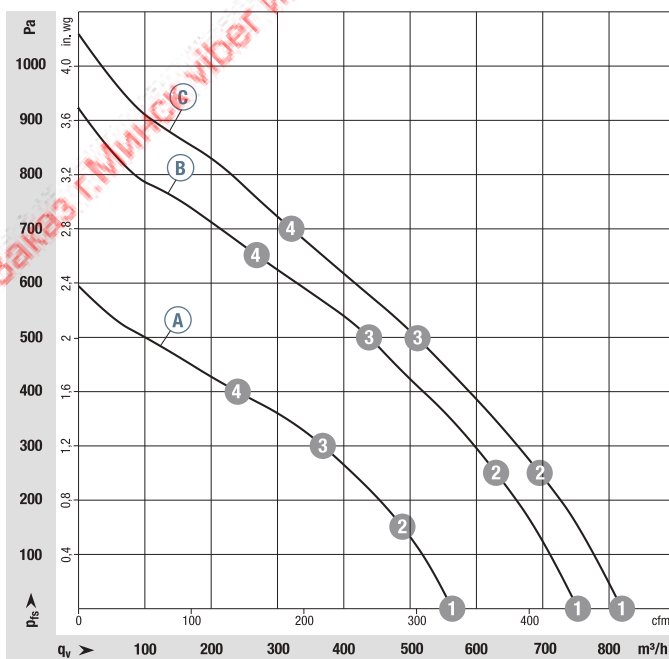

	n	P _{ed}	I
	rpm ⁻¹	W	A
Ⓐ 1	2700	90	8,60
Ⓐ 2	2670	92	8,84
Ⓐ 3	2600	96	9,25
Ⓐ 4	2685	92	8,80
Ⓑ 1	3050	125	5,20
Ⓑ 2	3085	131	5,43
Ⓑ 3	2965	132	5,50
Ⓑ 4	3065	130	5,40
Ⓒ 1	3150	125	2,60
Ⓒ 2	3070	128	2,70
Ⓒ 3	2985	130	2,70
Ⓒ 4	3085	127	2,70

Air performance measured according to: ISO 5801, installation category A, with ebm-papst inlet ring without contact protection. Suction-side noise levels: LWA according to ISO 13347, L_{pA} measured at 1 m distance from fan axis. The values given are applicable only under the specified measuring conditions and may differ depending on the installation conditions. In the event of deviation from the standard configuration, the parameters must be checked after installation! For detailed information see <http://www.ebmpapst.com/general-conditions>

Вентилятор ebmpapst Минск +375447584780 viber
www.fotorele.net www.tiristor.by радиодетали, электронные компоненты
email minsk17@tut.by tel.+375 29 758 47 80 мтс тел город 8(017)3779133

каталог, описание, технические, характеристики, datasheet, параметры, маркировка, габариты, фото,
модуль, Вентилятор, ebm-papst, ebmpapst, **w2s130**

КАТАЛОГ

ВЕНТИЛЯТОРЫ

ОСЕВЫЕ ВЕНТИЛЯТОРЫ

купить, продажа

электронные компоненты

[где и как купить в Минске?](#)

