

# EconoPACK™ & EconoPIM™ Series

## Application and Installation Notes

### About this document

#### Scope and purpose

This application note provides a guideline how to use and implement Econo modules. This Application Note includes the necessary technical information for users to realize a smooth system design with EconoPIM™ and EconoPACK™ modules. It is recommended to read through this document before starting the design with Econo modules.

#### Intended audience

This application note is for all users involved in handling power electronic devices. It is intended to be a guide for technicians and assembly workers to achieve proper usage of the module technologies described.

### Table of Contents

<b>About this document</b> .....	<b>1</b>
<b>Table of Contents</b> .....	<b>1</b>
<b>1 General</b> .....	<b>3</b>
<b>2 Delivery quality</b> .....	<b>4</b>
<b>3 Module storage and transport</b> .....	<b>5</b>
<b>4 IGBT modules are electrostatically sensitive devices (ESD)</b> .....	<b>6</b>
<b>5 Module identification</b> .....	<b>7</b>
<b>6 Module selection</b> .....	<b>8</b>
6.1 Selecting the module voltage class ( $V_{CES}$ ) and high altitude module operation.....	9
6.2 Climatic conditions in the active, current-carrying operation of EconoPACK™ and EconoPIM™ modules .....	11
<b>7 Module clearance and creepage distances</b> .....	<b>12</b>
<b>8 Connection and installation of the IGBT driver board</b> .....	<b>13</b>
8.1 Contacting the board with the PressFIT process .....	13
8.1.1 Requirements of the PressFIT holes of the circuit board .....	13
8.1.2 Contacting the board with a solder process .....	13
8.1.3 Mechanical relief of the PCB .....	14
<b>9 Mounting modules</b> .....	<b>16</b>
9.1 Condition of the heatsink for module mounting .....	16
9.2 Thermal Interface Material .....	17
9.2.1 Infineon Thermal Interface Material – IFX TIM .....	17
9.2.2 Applying standard thermal grease using the stencil printing method .....	18
9.2.3 Alternative method for applying standard thermal grease.....	19
9.3 Mounting the module on the heatsink .....	20



## Application and Installation Notes

---

### General

10	Use under vibration and shock loads .....	24
11	References .....	25
	Revision History .....	26

## 1 General

EconoPACK™ and EconoPIM™ series power semiconductor modules are electrical components.

An important aspect in the design of the mechanical structure is the conditions of use of the components [8]. These application conditions must be considered both in the mechanical design and the electrical design.

The advice and the recommendations in this document can not cover all types of applications and conditions. The installation and operating instructions in the AN2017\_03 therefore do not replace a thorough assessment and verification of the suitability for the intended use by the user through its technical departments.



## 2 Delivery quality

Since all IGBT modules are tested prior to delivery in a final test in accordance with IEC60747-9 and IEC60747-2 (at  $T_{vj} = 25\text{ °C}$  unless otherwise specified), there is no need for users to test the devices.

After a final visual inspection, the devices are packaged in a protected shipping box before delivery.

Depressions and/or elevations in the micron range are within the applicable Infineon specification limits, and do not affect the thermal, electrical or reliability characteristics of copper base plates for power modules.

After removing the devices from the protected shipping box, the user must observe the guidelines in section 4 for further processing.

### **3 Module storage and transport**

During transport and storage of the module, extreme forces caused by shock and/or vibration must be avoided. The same applies to extreme environmental conditions exceeding the recommended Infineon storage conditions according to [1].

While modules may be stored at the temperature thresholds specified in the data sheet, this is not recommended.

The storage period in accordance with the recommended storage conditions according to [1] should not be exceeded.

## Application and Installation Notes

### IGBT modules are electrostatically sensitive devices (ESD)

#### 4 IGBT modules are electrostatically sensitive devices (ESD)

IGBT semiconductors are electrostatically sensitive devices that must be handled according to ESD guidelines. Uncontrolled discharging, voltages from ungrounded equipment and people, as well as static discharges or similar influences can destroy these devices. The gate-emitter control terminals are the electrostatic sensitive contacts. It is important to ensure that IGBT modules are not operated or measured with open gate emitter connections.

Electrostatic discharge (ESD) can pre-damage IGBT modules or even destroy them.



Users must take care to avoid electrostatic discharge during handling, forwarding and packaging of these devices.

Important notes:

In order to prevent electrostatic discharge from destroying or pre-damaging the power semiconductors, the components are delivered in suitable packaging according to ESD guidelines.

ESD workstations are required to remove modules from their packaging and for handling the unprotected modules.

- All subsequent steps may only be performed on specialized workstations meeting the following requirements:
  - High-impedance ground connection
  - conductive working surface
  - ESD wrist straps
  - etc.
- All means of transport and PCBs must be brought to the same potential before further processing of the ESD components.

For more information, please refer to the applicable standards.

- IEC 61340-5-2, Electrostatics–protection of electronic devices from electrostatic phenomena–general requirements
- ANSI/ESD S2020
- MIL-STD 883C, Method 3015.6 for testing and Classification
- DIN VDE 0843 T2, identical with IEC801-2

**EconoPACK™ Series**

**Application and Installation Notes**

**Module identification**

**5 Module identification**

Infineon EconoPACK™ and EconoPIM™ Series modules are clearly marked with a product label (Fig. 1). For more information and material content data sheets, contact your Infineon distribution partners and sales offices.

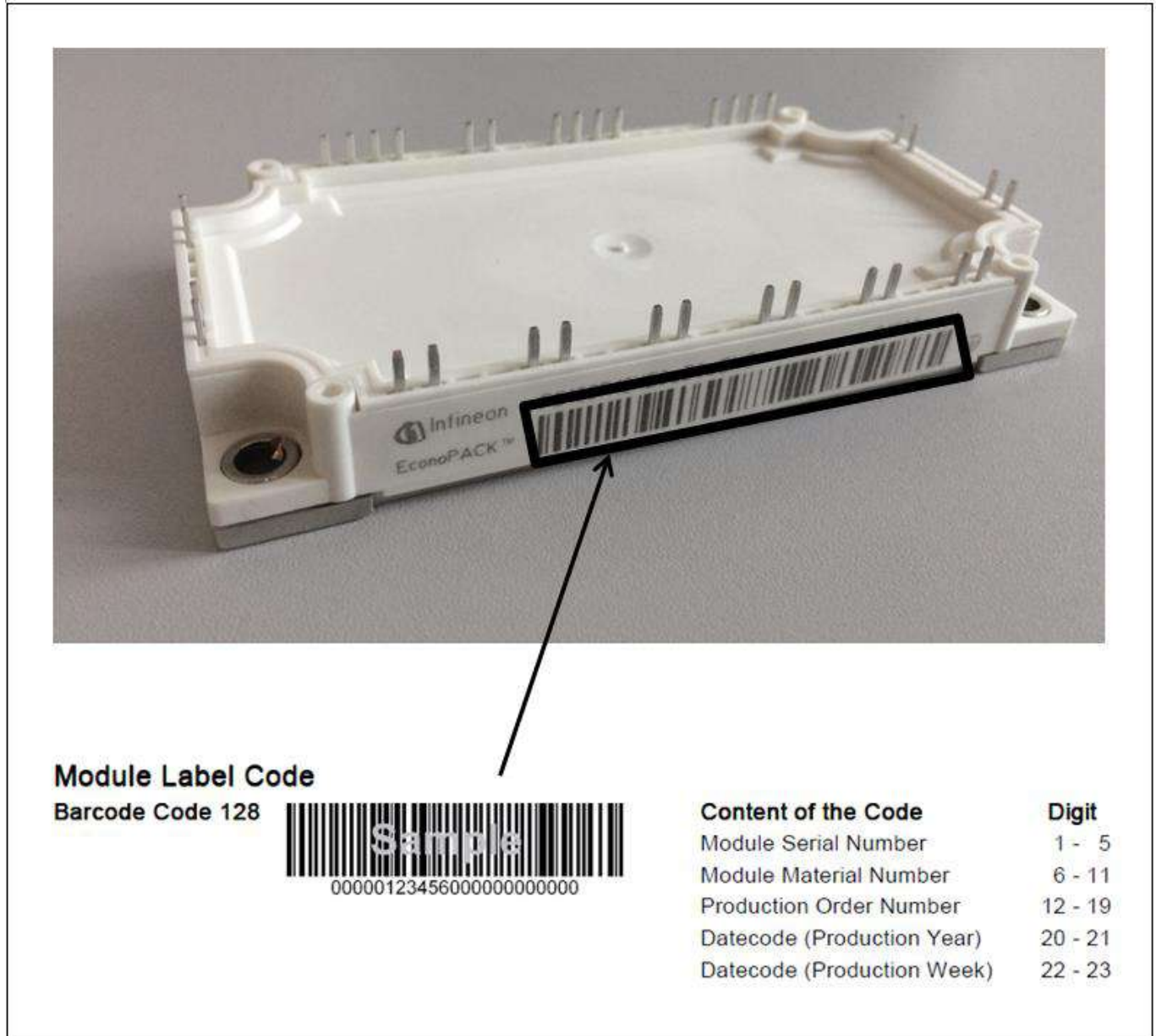

**Figure 1 Example: EconoPACK™ and EconoPIM™ Series module label**

## 6 Module selection

For a full PRODUCT OVERVIEW as well as a selection and simulation program (IPOSIM), visit [www.infineon.com](http://www.infineon.com).

The maximum values in the different product data sheets and the application notes are absolute limits which must not be exceeded, even for short periods of time, because this would pre-damage or even destroy the devices.

For more detailed information, please refer to the application notes in [2].

Different criteria must be taken into consideration when selecting the ideal device. The overview below provides orientation and explanations (Fig. 2 and Fig. 3).

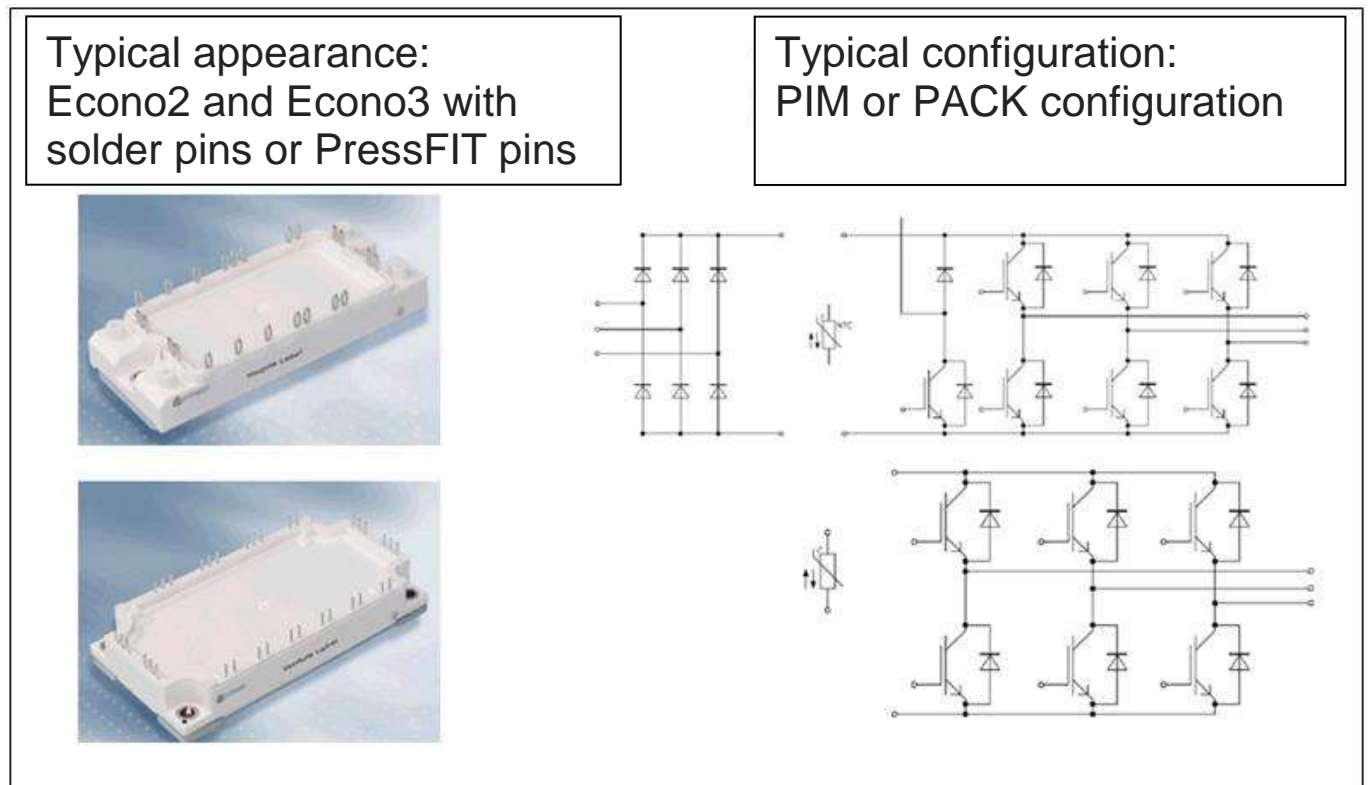

**Figure 2** Typical appearance of EconoPACK™ and EconoPIM™ series and typical module configuration



## Application and Installation Notes

### Module selection

IFS150R12K(N2/N3)T4P_B11	
I	MIPAQ™ Family
FS	FS=SixPACK
FP	FP=PIM
FF	FF=half-bridge
F4	F4= H bridge
150	max. collector continuous current (A)
R	Reverse-conducting
12	Collector emitter voltage in 100V
K	Mechanical design
N2/N3	Econo2 or Econo3
T4	Fast Trench IGBT
E4	low sat and fast Trench IGBT
P	Module with thermal interface material applied (IFX TIM)
B11	Design variant

**Figure 3 EconoPACK™ and EconoPIM™ Module Name Overview**

Almost all EconoPACK™ and EconoPIM™ -Series modules have an NTC temperature sensor, which is located within the device with a functional separation. For further information about using integrated NTC`s, see [9].

## 6.1 Selecting the module voltage class ( $V_{CES}$ ) and high altitude module operation

When selecting the appropriate voltage class, the IGBT must have a blocking capability that is suitable for the application and its conditions.

Table 2 shows possible IGBT voltage classes for different supply voltages. This table can be used for an initial IGBT module selection. The maximum permissible collector-emitter voltage ( $V_{CES}$ ) must not be exceeded even for a short time (e.g. during switching). It must be taken into account for the entire temperature range when selecting a suitable IGBT voltage class.

The following assumption [9] is suitable as a guide for selecting a potential IGBT voltage class:

$$U_{DC} = \sqrt{2} * U_{Nom,RMS} * \left[ 1 + \frac{S}{100\%} \right] \quad (1)$$

with S=Safety margin in [%]

## Application and Installation Notes

### Module selection

**Table 1 IGBT blocking capability as a selection criterion for the supply voltage**

Supply voltage $U_{Nom,RMS} \pm 10\%$	$U_{DC}$ nominal DC-link voltage	Typical IGBT voltage class (two level) $V_{CES}$
230V <sub>RMS</sub>	~ 360V	600V or 650V
400 V <sub>RMS</sub>	~ 620V	1.2kV
690 V <sub>RMS</sub>	~ 1070V	1.7kV

The transient collector-emitter voltage overshoot ( $\Delta U_{CE}$ ) at switch-off resulting from the current rate of rise ( $\frac{di_C}{dt}$ ) in combination with the parasitic inductance ( $L_\sigma$ ) of the IGBT must be taken into account when selecting an appropriate voltage class.

$$\Delta U_{CE} = -L_\sigma * \frac{di_C}{dt} \quad (2)$$

When power devices are used in geographical altitudes above mean sea level (MSL), e.g. at altitudes > 2000 m above sea level or at high DC voltages, restrictions of the operating range may become necessary.

- When air cooling is used, the cooling capacity of the overall system must be taken into account due to the lower air pressure.
- The insulating properties (especially those of the air gap) must be adjusted due to the lower dielectric strength of air, see also Section 7.
- Possible statistical failure rates due to the use of power devices at high altitude (cosmic radiation) and / or high voltage must be taken into account when selecting a suitable voltage class and during the design phase.
- With operating temperatures of  $T < 25^\circ\text{C}$ , the reduced blocking capability typical of IGBTs and the switching behavior of the devices with these temperatures must be taken into account in the application and investigated separately by the user with respect to the user design at its own risk. The blocking capability depending on the temperature of  $T = -40^\circ\text{C}$  to  $T = 25^\circ\text{C}$  is available on request from your Infineon power device distributor.

The cycling capability for the desired service life must be taken into account in the selection of the device, depending on the load profile.

## 6.2 Climatic conditions in the active, current-carrying operation of EconoPACK™ and EconoPIM™ modules

EconoPACK™ and EconoPIM™ modules are not hermetically sealed. The cases and the single-layer grouting used for electrical insulation in the module are permeable to moisture and gases in both directions. This means that moisture differences can be compensated in both directions.

In active, current-carrying operation, EconoPACK™ and EconoPIM™ modules from Infineon are specified for climatic conditions according to EN60721-3-3 with the classification of environmental conditions for stationary use according to class 3K3.

The modules may not be exposed to moisture (e.g. dew or condensation) and climatic conditions which go beyond the category 3K3 of EN60721-3-3 must be avoided by taking additional measures for every application.

Harmful gases must be avoided in operation and during storage.

## Application and Installation Notes

### Module clearance and creepage distances

## 7 Module clearance and creepage distances

When specifying the insulation properties, application-specific standards must be observed, particularly with regard to the clearance and creepage distances.

The module-specific EconoPACK™ and EconoPIM™ series case drawings can be taken from the data sheets.

Specifically, the clearance and creepage distances must be taken into account when selecting screws and washers. Please note the information provided in Section 6.1. Depending on the requirements of each application, electrically conducting components or vias should be avoided or insulation should be provided, for example by painting the relevant surfaces.

The clearance and creepage distances specified in EconoPACK™ and EconoPIM™ series data sheets specify the shortest clearance and creepage distances for mounted module at a contamination level of 2 according to IEC60664-1. This is shown in Figure 2.

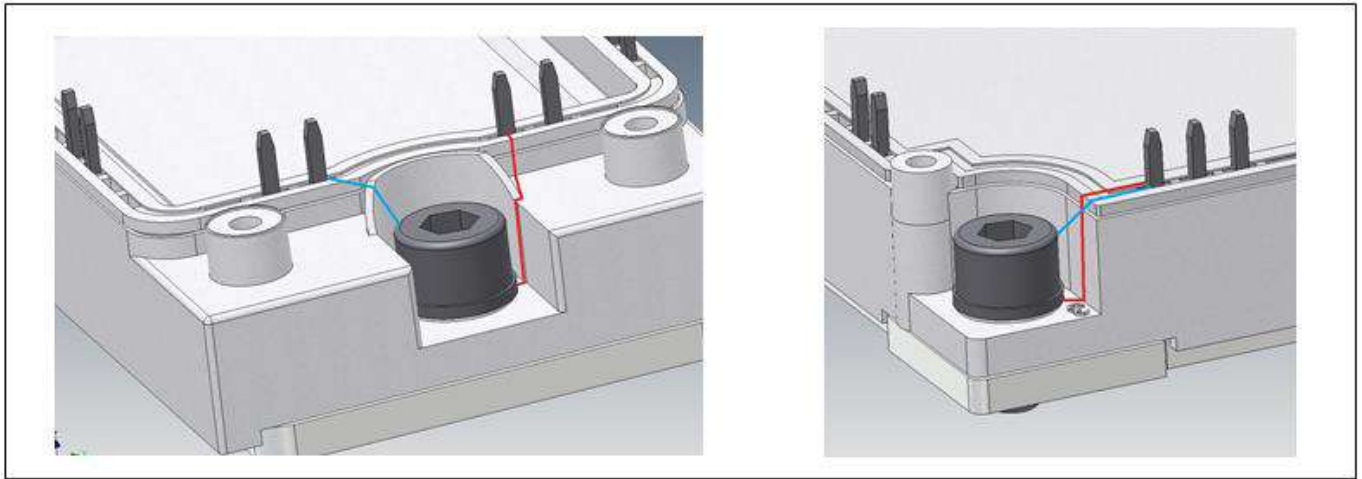

**Figure 4** Typical EconoPACK2™ and EconoPACK3™ module  
(blue = clearance distance ; red = creepage distance)

**Table 2** Data sheet specifications for clearance and creepage distances

<b>Creepage distance</b>	<b>Terminal to heatsink</b>		10.0	mm
<b>Clearance distance</b>	<b>Terminal to heatsink</b>		7.5	mm
<b>Comparative tracking index</b>		CTI	>200	

In each case, the application's clearance and creepage distances must be verified, compared with the requirements of the application-specific standards and ensured by design measures if necessary.

## Application and Installation Notes

---

### Connection and installation of the IGBT driver board

## 8 Connection and installation of the IGBT driver board

**Users must take precautions against electrostatic discharges that may occur when touching or processing IGBT modules. See Section 4.**

The IGBT driver board must be dimensioned to ensure safe device operation.

The gate voltage should be in the range of

$V_{GE} = +15V / -15V \dots -7V$  for more detailed information, please refer to the application notes in [6] and [7].

### 8.1 Contacting the board with the PressFIT process

#### 8.1.1 Requirements of the PressFIT holes of the circuit board

Infineon's PressFIT contact technology for power electronics modules allows fast and safe cold-welded connections for standard FR4 PCBs with immersion tin surfaces. The preparation of printed circuit boards is described in detail in AN2007\_09.

#### 8.1.2 Contacting the board with a solder process

The control contacts of EconoPACK™ and EconoPIM™ series modules have a solderable surface that allows contacting by means of suitable soldering methods.

After placing the PCBs, the connection can be made by means of manual soldering, automatic selective soldering, wave soldering or other methods.

If the modules are preheated before they are fed to the soldering process, the process must be adjusted so that a preheating temperature of  $T \leq 125 \text{ }^\circ\text{C}$  is not exceeded for  $t \leq 30\text{min}$ .

During the entire soldering process, care must be taken to ensure that the process parameters, the solder temperature and the time the modules are in touch with the contacts do not cause deformation of the plastic housing and thereby damage it. During the soldering process, a maximum soldering temperature of  $T = 260 \text{ }^\circ\text{C} \pm 3 \text{ }^\circ\text{C}$  is permissible for a maximum duration of  $t_{\max} \leq 10\text{s} \pm 1\text{s}$  according to IEC 60068-2-20.

Different process parameters must be tested by users at their own risk and can be evaluated in cooperation with Infineon. We assume that the components are free from defects and treated properly.

For more information about soldering processes, refer to [10].

## Application and Installation Notes

### Connection and installation of the IGBT driver board

#### 8.1.3 Mechanical relief of the PCB

After contacting the connection pins with the PCB as described in Sections 8.1.1 and 8.1.2 above, it is advisable to mechanically relieve the contact points between board and module. The contact points should be relieved by attaching the board with the driver board directly on the module at the 4 fixing points (Fig. 5) using self-tapping or metric screws.

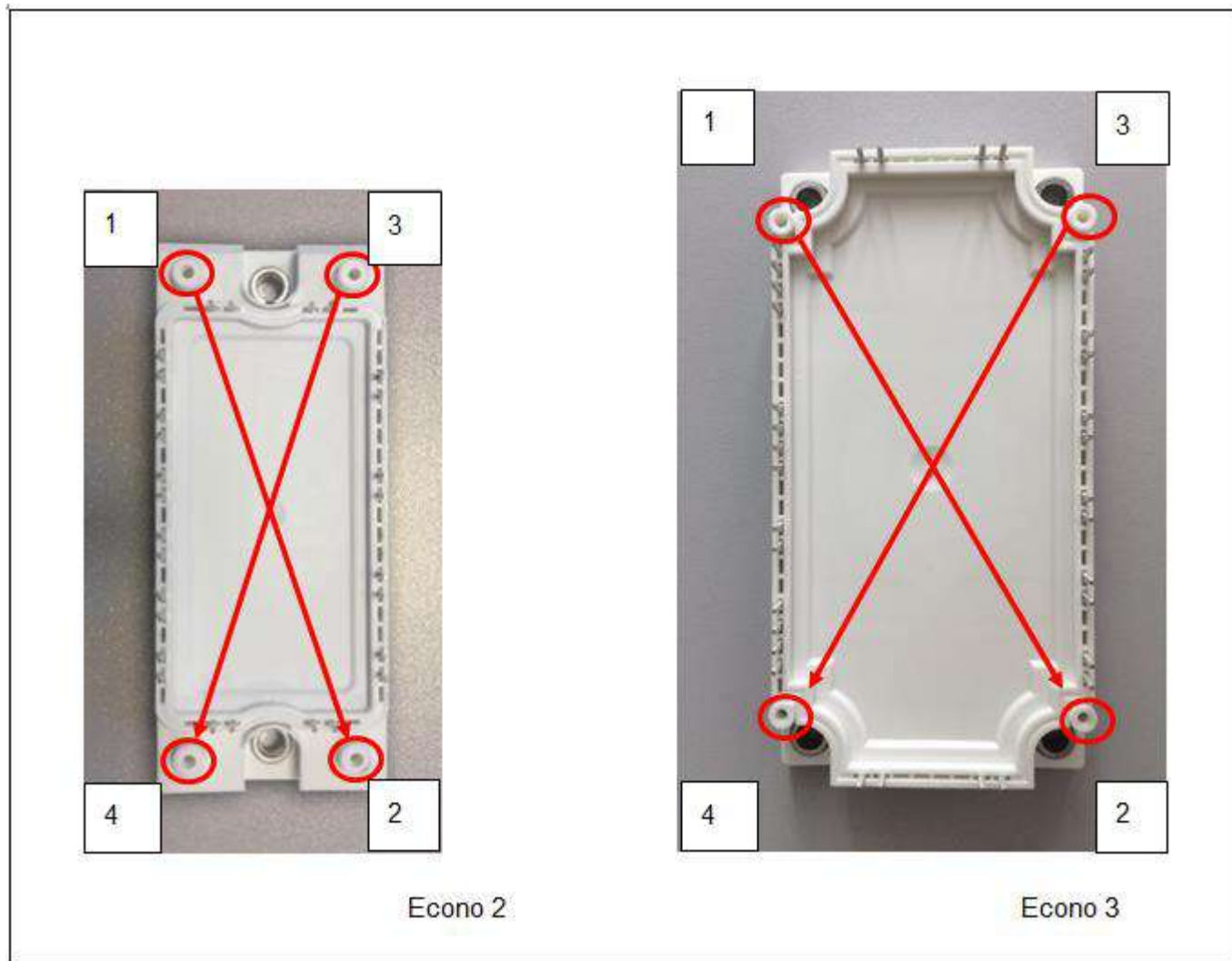

**Figure 5 EconoPACK™ and EconoPIM™ series**

The screw thread extending into the mounting tube should have an effective minimum length of  $l_{\min} \geq 4\text{mm}$  and an effective maximum length of  $l_{\max} \leq 10\text{mm}$ , taking the board thickness used and the driver weight into account.

The first 1.5 mm in the mounting tube are for guiding purposes and cannot absorb forces. The thread in the plastic is created automatically as the screws rotate. Self-tapping screws or metric screws can be used for attaching a PCB depending on the PCB thickness used.

Use of metric screws: M 2.5 \* 8 or M 2.5 \* 10

## Application and Installation Notes

### Connection and installation of the IGBT driver board

Recommended self-tapping screw types:

EJOT PT K 25 x 10 Art. No. 4012470801 at 500 revolutions with a recommended maximum torque of 0.5Nm.

EJOT DELTA PT 25 x 10 Art. No. 4229110801 at 500 revolutions with a recommended maximum torque of 0.5Nm.

To avoid damage to or bursting of the receiving tube, care must be taken to ensure that the screw is inserted into the tube in a straight manner (Figure 6).

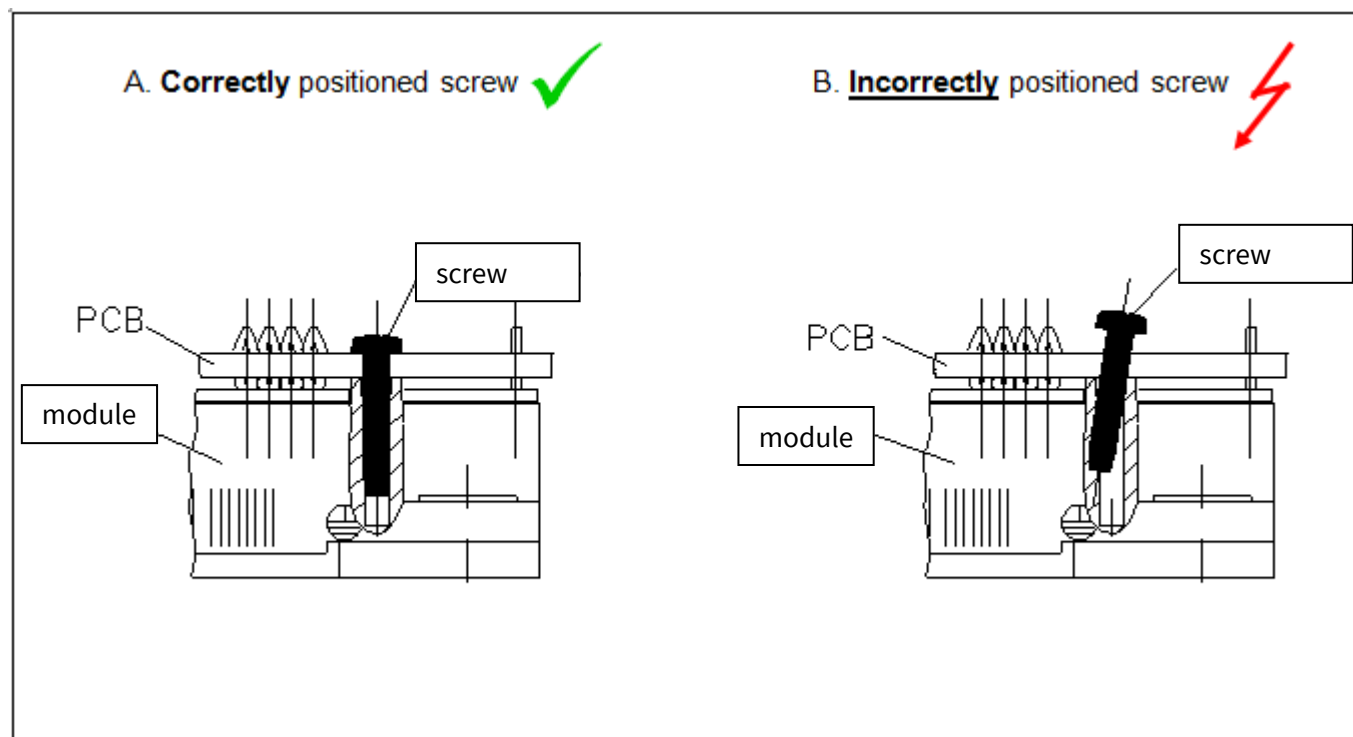

**Figure 6 EconoPACK™ series with PressFIT contacts connected with a circuit board**

The recommended screws are based on laboratory tests. Depending on the screw or tool used, it may be necessary to adjust the tightening process accordingly.



## Application and Installation Notes

### Mounting modules

## 9 Mounting modules

When two or more modules are used in one PCB, care must be taken to ensure that the base plates are on the same level after the soldering or press-fit process. This is necessary so that an optimum connection can be realized from the base plates to the heatsink. Supports between circuit board and heatsink should be positioned so that the heavy components on the circuit board have no effect on the module and on the desired vibration behavior of the entire device. The supports should create a pressure effect on the module. They should not have a traction effect [11].

### 9.1 Condition of the heatsink for module mounting

The power loss in the module must be dissipated via a heat sink in order to avoid exceeding the maximum permissible temperature specified in the data sheets in switching mode ( $T_{vjop}$ ) during operation.

The property of the heatsink surface in the area where the module is mounted is key because this connection between the heatsink and the module is critical for dissipating the heat of the overall system.

The contact surfaces, the base plate of the module and the surface of the heatsink must be free from damage and contamination and should be cleaned before mounting the module using clean, lint-free cloths.

The contact surface of the heatsink should not exceed the following values depending on module length:

Surface flatness  $\leq 50\mu\text{m}$

Surface roughness  $R_z \leq 10\mu\text{m}$

The heatsink must possess sufficient stiffness for the installation and the subsequent transport in order to avoid exerting additional stretching and/or tensile forces on the bottom plate of the module. During the entire installation process, the heatsink must be handled in a torsion-free manner.

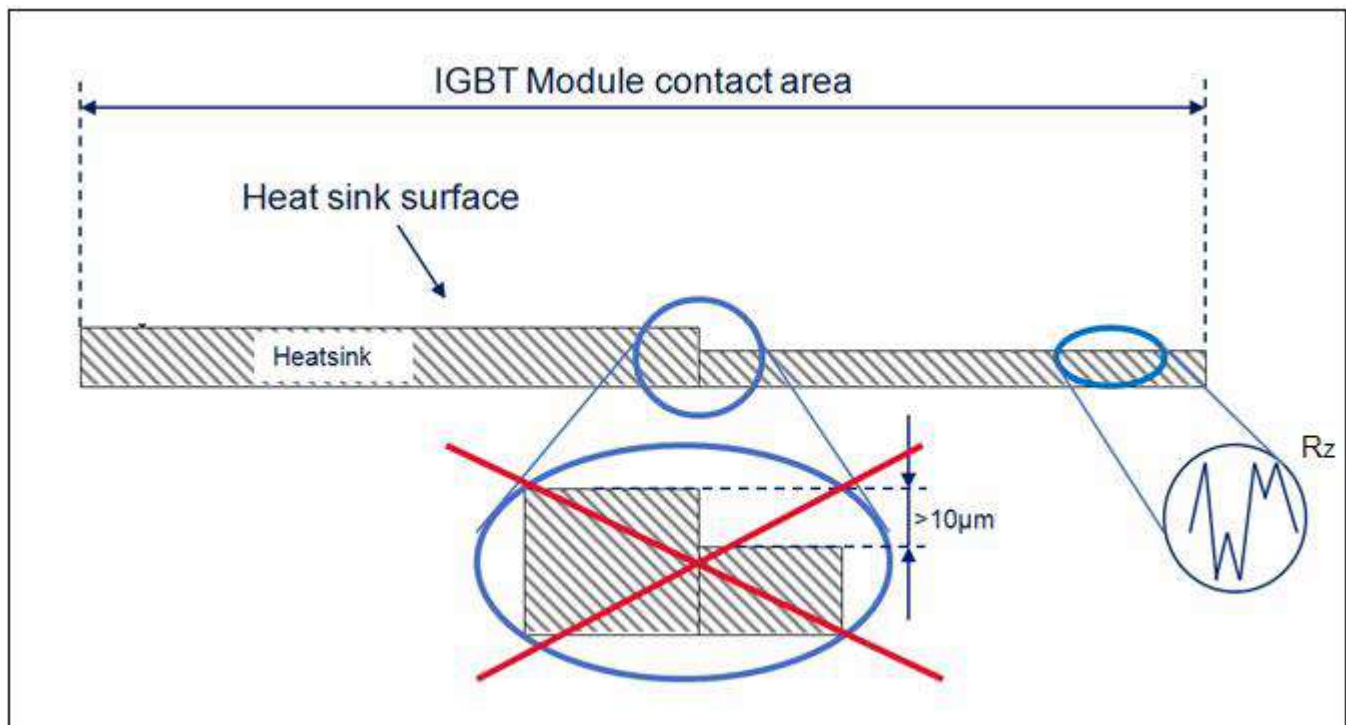

**Figure 7** Recommendation for the quality of the heatsink surface for module installation



## Application and Installation Notes

### Mounting modules

## 9.2 Thermal Interface Material

Due to the different surface shapes of the module base plate and the heatsink, the surfaces are not completely flush with each other and gaps between the 2 components cannot be avoided in places on the contact areas.

To dissipate the losses occurring in the module and to achieve a good heat flow into the heatsink, all spaces should be filled with a suitable heat-conducting material.

The thermally conductive material should have stable long-term properties to ensure the thermal resistance remains on a constant high level. It should be applied in such a way that no screw holes are blocked, avoiding negative effects on tightening torques.

### 9.2.1 Infineon Thermal Interface Material – IFX TIM

Infineon has developed IFX TIM, a material optimized for semiconductor power modules providing long-term stability and thoroughly excellent properties.

EconoPACK™ and EconoPIM™ modules from Infineon distribution partners and sales offices are available with IFX TIM already applied. These modules have the letter P in their type designation. For more detailed information, please refer to [4].

Example of a print image on the IGBT module base plate after applying the IFX TIM material:

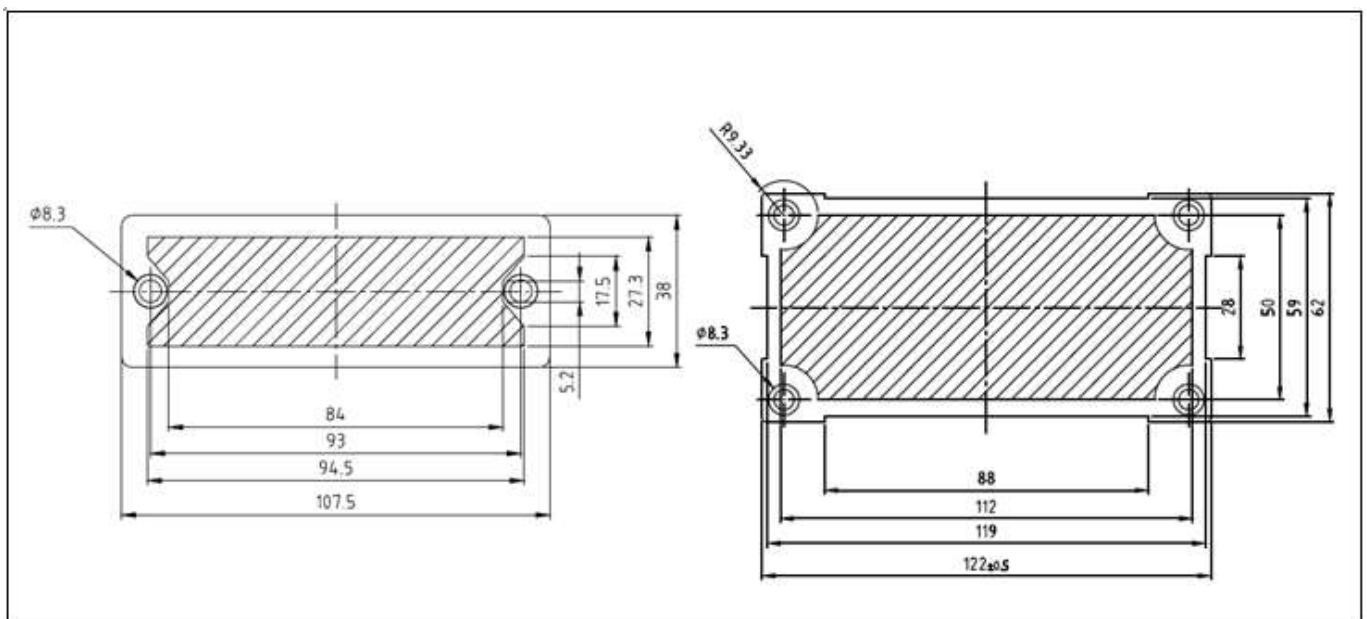

**Figure 8 EconoPACK™ series module with IFX TIM**

For EconoPACK™ and EconoPIM™ series modules with IFX TIM already applied by Infineon continue with Section 9.3.

Fig. 8 shows the areas of the Econo2 and Econo3 base plates where TIM is applied.

## Application and Installation Notes

### Mounting modules

#### 9.2.2 Applying standard thermal grease using the stencil printing method

When using modules where the thermal interface material (IFX TIM) is NOT applied by the manufacturer, the user has to select and qualify the thermal interface material with respect to fitness for purpose and long-term stability.

The suitability of the option of applying heat conductive material such as thermal grease by means of a stencil should always be investigated by the user at its own risk in each individual case in combination with the conductive material selected and the heatsink surface.

To achieve optimum results, the module, the application geometry, the sink contact surface and the material applied should be considered holistically.

The manual application of thermal grease with a layer thickness in the micrometer range is inherently problematic because a well applied layer should fill all of the gaps while allowing the metallic contact between the base plate and heatsink surface. The thermal stencil printing process is therefore recommended for applying thermal grease. This method allows the user to achieve optimum thermal grease distribution for the module while defining a layer thickness that can be easily reproduced.

For more detailed information on using stencils or applying thermal grease, please refer to the application notes in [5].

The figures below show examples of how thermal grease can be applied using the template printing method.

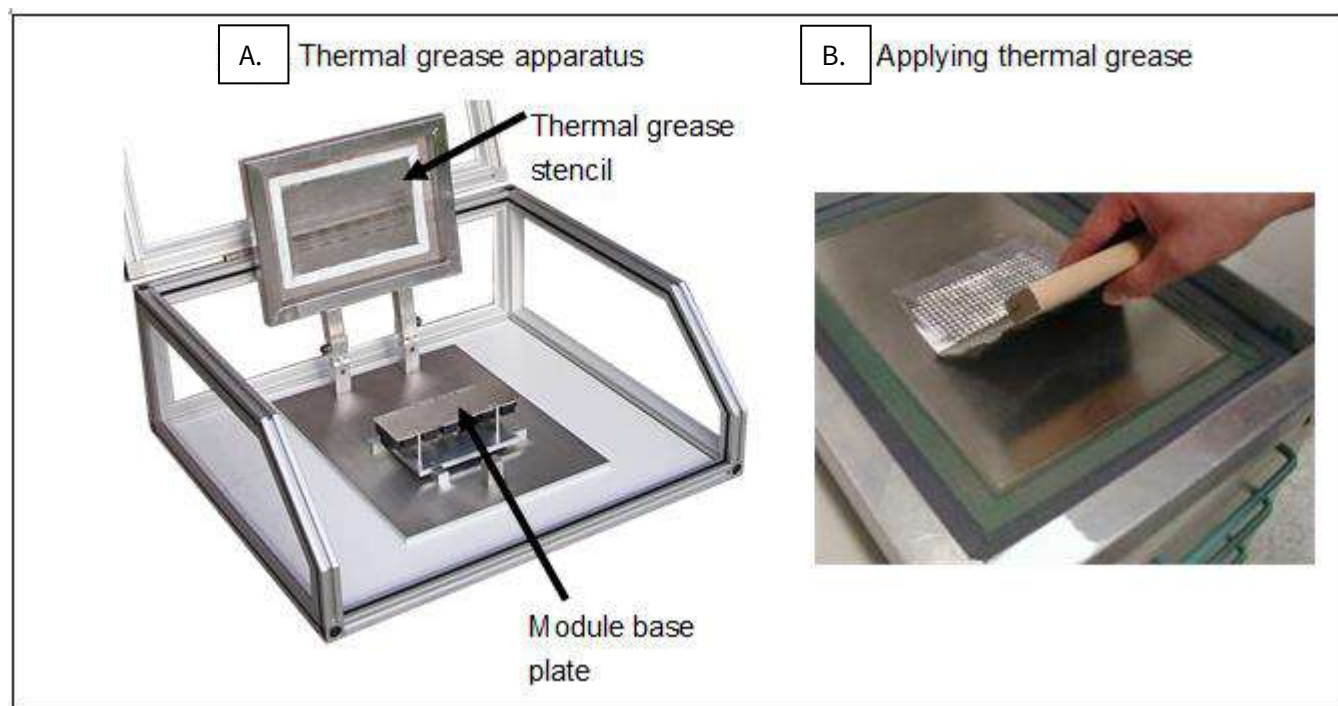

**Figure 9** A. Example of an apparatus for applying thermal grease using the stencil printing process, showing a module with its base plate  
B. Application of the thermal grease onto the stencil

## Application and Installation Notes

---

### Mounting modules

As shown at figure 9 a recommendation to use such apparatus:

1. Remove thermal grease residues from the stencil, if any. This cleaning step can be carried out with suitable solvents. The safety regulations for handling these materials must be observed.
2. Align the stencil and the module with each other. For this purpose, you can use an apparatus that can be inserted into the module as shown in Figure 9A.
3. Lower the stencil onto the module base plate.
4. Apply the heat conducting media through the stencil (see Fig. 9B), ensuring that all stencil holes are filled with thermal grease.
5. Fold up the stencil and remove the module.
6. Use a visual inspection after the application of the material to ensure that each point of the template is filled. Even when applying thermal paste using a stencil (especially if this is done manually), the expected temperature change can vary by a few Kelvins if the stencil is poorly aligned or if the thermal grease quantity varies slightly.
7. It is therefore highly advisable to measure the layer thickness of the material applied to ensure that an adequate quantity is applied.

Possible stencil wear and accompanying thickness reduction must be checked from time to time by applying thermal grease to the stencil using a tool. Stencils must be replaced if they no longer have the required thickness.

### 9.2.3 Alternative method for applying standard thermal grease

When using modules where the thermal interface material (IFX TIM) is NOT applied by the manufacturer, the user has to select and qualify the thermal interface material with respect to fitness for purpose and long-term stability.

If it is not possible to apply standard thermal grease using the recommended method of stencil printing, the heat transfer medium may be applied manually. A uniform thermal grease layer thickness of typically 80-100 microns on the base plate of the module is considered sufficient. The user must select and qualify the thermal interface material and the process with respect to fitness for purpose and long-term stability at its own risk.

As a guide, the required amount of thermal grease depending on layer thickness is as follows:

$$d = 80 \mu\text{m}: V \approx 1.6 \text{ cm}^3,$$

$$d = 100 \mu\text{m}: V \approx 2.0 \text{ cm}^3.$$

This volume may meter from a syringe or applied using a tube.

Common rollers or fine toothed spatula can be used to apply the thermal grease. The uniformity and reproducibility of the self-adjusting layer thicknesses following manual application is subject to large

## Application and Installation Notes

### Mounting modules

tolerances. The thickness of the thermal grease after application can be checked using a wet film comb, see Fig. 10.

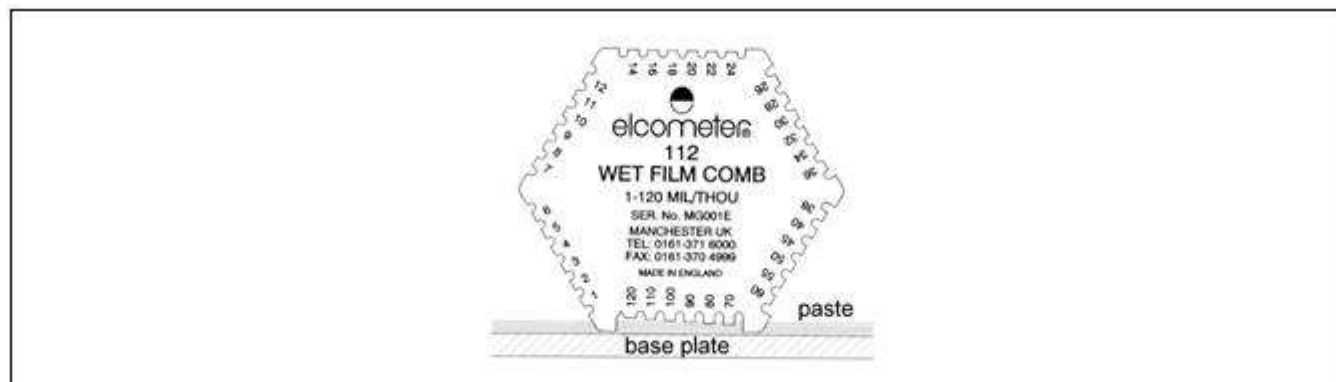

**Figure 10 Wet film comb for measuring thermal grease thickness**

Processing guidelines, thermal contact and long-term stability of thermal materials must be considered. The user must take these aspects into account when selecting these materials depending on the process and the application at its own risk, and also discuss them with the thermal grease manufacturer if necessary.

### 9.3 Mounting the module on the heatsink

Modules must be mounted to the tolerances specified in the data sheets. The module-specific case drawings can be taken from the data sheets.

The screw connection for mounting the module to the heatsink must be designed in such a way that the total of all possible loads does not exceed the flow limits of the assembled parts. Friction devices such as spring washers increase the elasticity of the connection and compensate settling effects. This serves to maintain most of the preload force, preserving the connection.

The tightening torque must be selected so that the preload force applied leads to a purely frictional connection of the components. To accurately determine the preload force and the tightening torque, the friction coefficient  $\mu$  must be known. The friction depends on many different factors, such as material combination, surface, lubrication, temperature, etc. For a typical, clean combination of an aluminum heatsink with a galvanized M6 steel screw, a friction coefficient of  $\mu_G \approx 0.14$  results. If the actual coefficient of friction differs from this standard value, the tightening torque must be adapted accordingly.

Ideally, the screws should be tightened with a torque close to the maximum recommended torque  $M_{Max}$ . This maximum torque must not be exceeded, however.

**Table 3 Specifications of the fastening screw**

Description	Values	Comment
Fastening screw	M5	1.)
Maximum recommended tightening torque	$M_{max} = 6\text{Nm}$	2.)
Recommended strength class of the screw	8.8	3.)
Minimum thread reach into the heatsink	$1.6 \times \text{dia.} = 8\text{ mm}$	4.)

## Application and Installation Notes

### Mounting modules

- 1.) according to ISO4762, DIN6912, DIN7984, ISO14581 or DIN7991 in combination with a suitable washer, e.g. according to DIN433 or DIN125 or complete combination screws according to DIN6900, recommended for module mounting.
- 2.) Determined for a friction coefficient of  $\mu_G = 0.14$  (screw clean and dry, aluminum heatsink, screw according to ISO14581, galvanized, rolled thread). The torque applied should be based on the maximum torque.
- 3.) But at least 6.8
- 4.) In aluminum; according to the technical literature

Other material combinations of screws and/or heatsink material may require a modification of the mechanical parameters and an evaluation of the corrosion resistance.

The module mounting screws must be uniformly tightened crosswise using a torque within the specified limits.

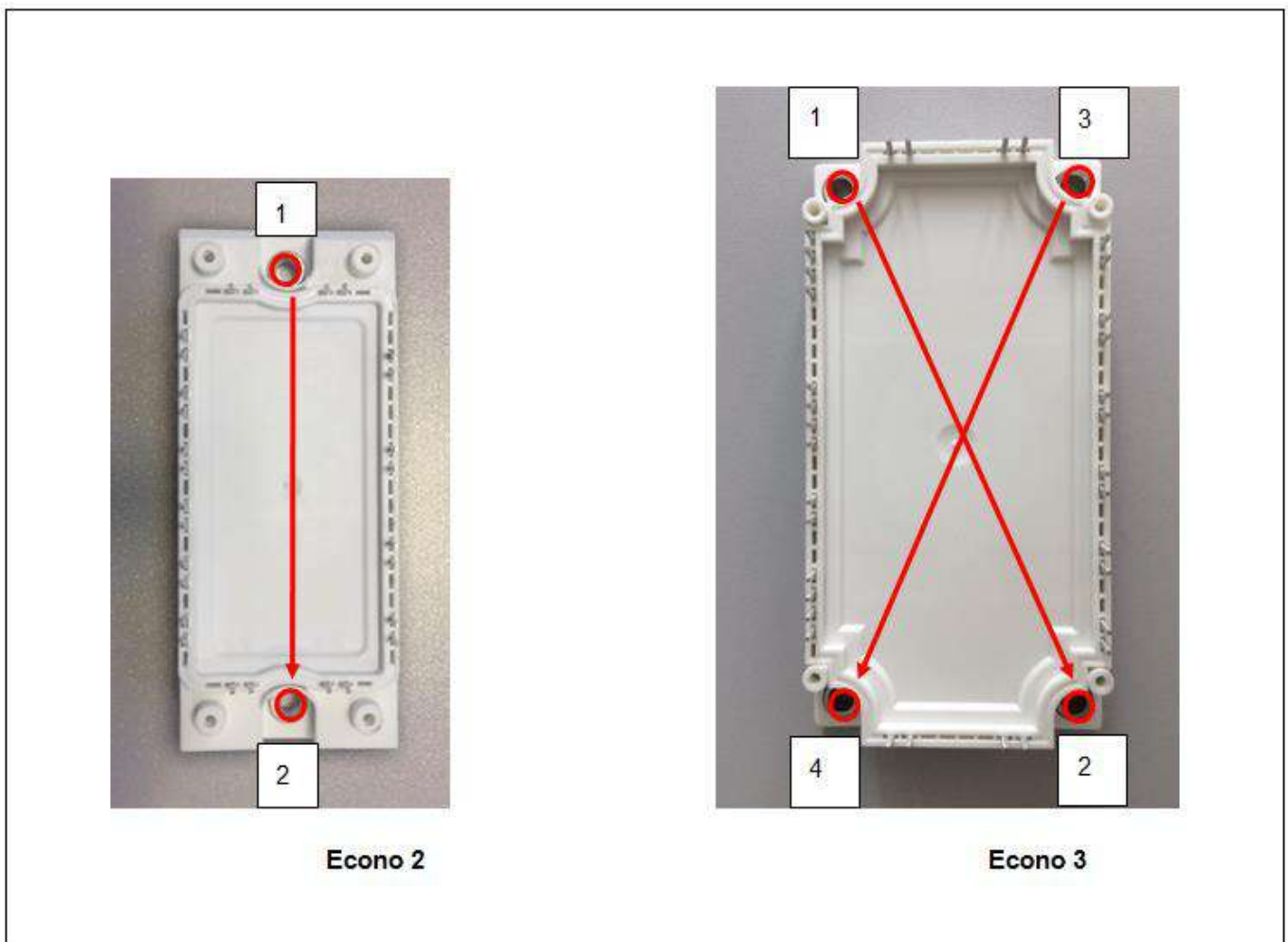

**Figure 11** Screw sequence for module mounting

For optimal thermal contact of the module on the heatsink, the following procedure is recommended when tightening the fastening screws - 1 to 4 for Econo3 and 1 to 2 for Econo2 (Fig. 11).

## Application and Installation Notes

---

### Mounting modules

1. Place module with the thermal grease applied onto the clean heatsink and fix in place using two screws screwed in by about half their length.
2. With Econo3, screw in the remaining screws by about half their length.
3. For the Econo3, tighten all screws crosswise using a torque of approximately 0.5 Nm in the following sequence: e.g. screw No. 1 - 2 - 3 - 4 (see Fig. 11).

When using Infineon modules where the thermal interface - IFX TIM - has already been preapplied, you can continue with step 4.

If you do NOT use the IFX TIM material recommended and pre-applied by Infineon, an additional intermediate step 3.a may be required depending on the viscosity of the alternative material used (e.g. in case of high viscosity) to allow the thermal grease to flow as the screws are tightened, adapting to the contours of the module base plate and the heatsink. Then, proceed to step 4.

3.a. After a pause, tighten the screws crosswise to approximately 0.5 Nm in the same sequence.

The pause depends on the material used and must be determined by the user at its own risk based on examinations/tests with the preferred material. As a guide for the initial investigations during the development phase, a pause of 10 to 20 minutes can be assumed.

e.g. screw No. 1 - 2 - 3 - 4

4. Tighten the screws crosswise to 3 - 6Nm in the same sequence.

e.g. screw No. 1 - 2 - 3 - 4

The tightening sequence should be applied for all EconoPACK™ and EconoPIM™ series modules.

When using standard thermal grease, it may be necessary to check the tightening torque of the fixing screws after a heat test depending on the type of grease used. It is highly advisable to perform this step if you use phase change films for thermal conduction instead of thermal grease. Silicone films are not suitable for power devices and are therefore not recommended.

Users should carry out their own tests and measurements with their preferred thermal grease or an alternative material for qualifying and verifying the mounting process and the suitability of the thermal design. The maximum junction temperature should be determined by means of thermal measurements under normal operating conditions. The maximum junction temperature may not exceed the junction temperature ( $T_{vjop}$ ) specified in the data sheets in pulse mode [3]!

For a thermal measurement as close to the chip as possible, it is necessary to position the probe under the chip to be measured (Fig. 12). Knowledge of the exact chip positions is therefore indispensable.

## Application and Installation Notes

### Mounting modules

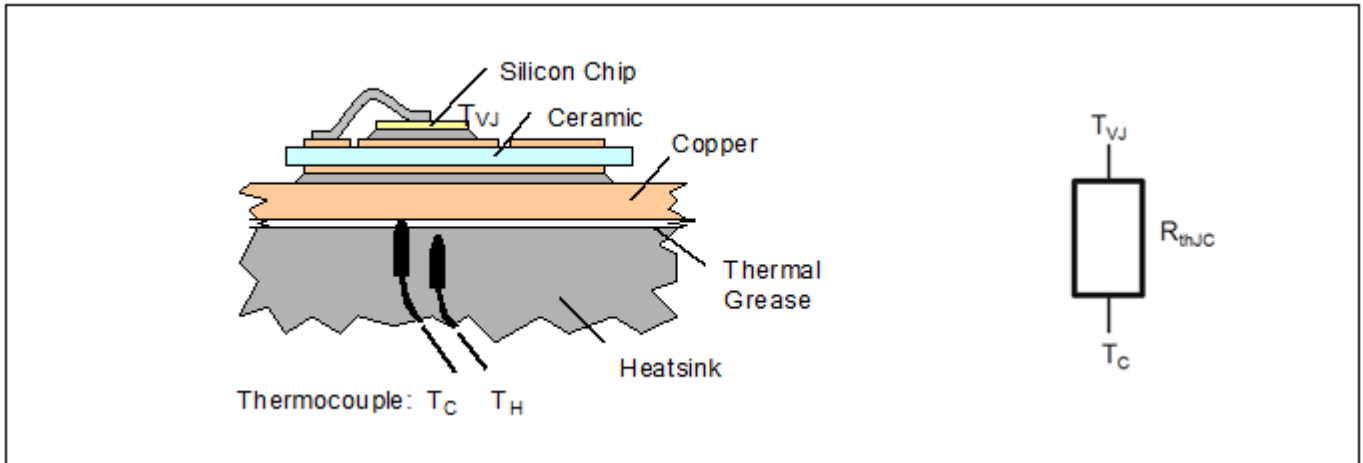

**Figure 12** Example of the arrangement of the temperature sensor in a thermal measurement

The junction temperature  $T_{VJ}$  can be determined as follows if the actual switching and conduction losses ( $P_V$ ) and the base plate temperature ( $T_C$ ) are known:

$$T_{VJ} = T_C + P_V * R_{thJC} \quad (2)$$

$T_{VJ}$ : Junction temperature (virtual)

$T_C$ : base plate temperature

$P_V$ : Total power loss

$R_{thJC}$ : Thermal resistance, junction to case



## **10 Use under vibration and shock loads**

The modules of the EconoPACK™ and EconoPIM™ series have a mechanical design corresponding to the state of the art, which was developed with the clear focus of providing maximum mechanical ruggedness to the application.

Vibration and shock should be avoided.

The effects of permanent mechanical stresses, particularly recurring stresses such as vibration and shock, on the module are highly dependent on the mechanical design and the load profile of the application.

The suitability of these modules for use under such specific mechanical loads must therefore be investigated and qualified by the user at its own risk for its specific design and the load profile occurring in the intended application.



References

## 11 References

- [1] TR14 Storage of Products supplied by Infineon Technologies
- [2] AN2011\_05 Industrial IGBT Modules - Explanation of Technical Information
- [3] AN2008\_01 Definition and use of junction temperature values
- [4] AN2012\_07 Modules with pre-applied Thermal Interface Material
- [5] AN2006\_02 Application of screen print templates
- [6] AN2006\_01 Driving IGBT`s with unipolar gate voltage
- [7] AN2007\_04 Deadtime calculation
- [8] Infineon Technologies IGBT Modules -Technologies, Driver and Application, A.Volke, M.Hornkamp, ISBN 978-3-00-032076-7
- [9] AN2009\_10 Using the NTC inside a power electronic module
- [10] AN2005\_06 Soldering of Econo and Easy modules
- [11] AN2007\_09 PressFIT mounting technology  
Mounting instruction for PressFIT modules with forked pins



## Revision History

### Major changes since the last revision

Page or Reference	Description of change

#### Trademarks of Infineon Technologies AG

$\mu$ HVIC™,  $\mu$ IPM™,  $\mu$ PFC™, AU-ConvertIR™, AURIX™, C166™, CanPAK™, CIPOS™, CIPURSE™, CoolDP™, CoolGaN™, COOLiR™, CoolMOS™, CoolSET™, CoolSiC™, DAVE™, DI-POL™, DirectFET™, DrBlade™, EasyPIM™, EconoBRIDGE™, EconoDUAL™, EconoPACK™, EconoPIM™, EiceDRIVER™, eupec™, FCOS™, GaNpowIR™, HEXFET™, HITFET™, HybridPACK™, iMOTION™, IRAM™, ISOFACE™, IsoPACK™, LEDrivIR™, LITIX™, MIPAQ™, ModSTACK™, my-d™, NovalithIC™, OPTIGA™, OptiMOS™, ORIGA™, PowIRaudio™, PowIRstage™, PrimePACK™, PrimeSTACK™, PROFET™, PRO-SiL™, RASIC™, REAL3™, SmartLEWIS™, SOLID FLASH™, SPOC™, StrongIRFET™, SupIRBuck™, TEMPFET™, TRENCHSTOP™, TriCore™, UHVIC™, XHP™, XMCT™

Trademarks updated November 2015

#### Other Trademarks

All referenced product or service names and trademarks are the property of their respective owners.

**Edition** 2017-03-10

**Published by**

**Infineon Technologies AG**

**81726 Munich, Germany**

**© 2017 Infineon Technologies AG.**

**All Rights Reserved.**

**Do you have a question about this document?**

**Email:** [erratum@infineon.com](mailto:erratum@infineon.com)

**Document reference**

**AppNote Number** 2017\_3

#### IMPORTANT NOTICE

The information contained in this application note is given as a hint for the implementation of the product only and shall in no event be regarded as a description or warranty of a certain functionality, condition or quality of the product. Before implementation of the product, the recipient of this application note must verify any function and other technical information given herein in the real application. Infineon Technologies hereby disclaims any and all warranties and liabilities of any kind (including without limitation warranties of non-infringement of intellectual property rights of any third party) with respect to any and all information given in this application note.

The data contained in this document is exclusively intended for technically trained staff. It is the responsibility of customer's technical departments to evaluate the suitability of the product for the intended application and the completeness of the product information given in this document with respect to such application.

For further information on the product, technology, delivery terms and conditions and prices please contact your nearest Infineon Technologies office ([www.infineon.com](http://www.infineon.com)).

#### WARNINGS

Due to technical requirements products may contain dangerous substances. For information on the types in question please contact your nearest Infineon Technologies office.

Except as otherwise explicitly approved by Infineon Technologies in a written document signed by authorized representatives of Infineon Technologies, Infineon Technologies' products may not be used in any applications where a failure of the product or any consequences of the use thereof can reasonably be expected to result in personal injury.

# модуль Еурес, Infineon, igbt Еурес, Infineon в Беларуси

купить, продажа



**Электронные компоненты, радиодетали**

[где и как купить в Минске?](#)

Категория: модуль Еурес, Infineon, , igbt, мост диодный

## КАТАЛОГ ЕУРЕС, INFINEON, 2020 МИНСК

каталог, описание, технические, характеристики, datasheet, параметры, маркировка, габариты, фото, семикрон, Еурес, Infineon, , мост, диодный, однофазный, трехфазный, igbt, модуль