

**NIDEC ULTRAFLO, Минск +375447584780 Viber email [minsk17@tut.by](mailto:minsk17@tut.by)  
[www.fotorele.net](http://www.fotorele.net) [www.tiristor.by](http://www.tiristor.by) tel.+375 29 758 47 80 МТС**

# nidec ultraflo

купить, продажа



**Электронные компоненты, радиодетали**

[где и как купить в Минске?](#)

каталог, описание, технические, характеристики, datasheet, параметры, маркировка, габариты, фото,  
nidec ultraflo, **аналог, замена**, вентилятор

**КАТАЛОГ вентиляторы**

# nidec ultraflo

**2020 МИНСК**

**Nidec**

All for dreams

勝特力材料 886-3-5753170  
勝特力电子(上海) 86-21-34970699  
勝特力电子(深圳) 86-755-83298787  
[Http://www.100y.com.tw](http://www.100y.com.tw)

**UltraFlo**

Cooling Fans

**Nidec  
UltraFlo**

Заказ г.Минск вібер и тел. +375447584780 email: n...

日本電産株式会社

Computers and home appliances, whose quality has advanced rapidly in recent years, have been producing increasingly more heat. Fan motors are essential to cool such products, and have seen their usage and application widen more than ever before.

This recent market trend requires fan motors to possess higher cooling and noise reduction capabilities. The fan motors in the Nidec **UltraFlo** series, an advanced version of conventional motors, are not only excellent in airflow creation, static pressure control and efficiency, they are also low-noise, low-vibration and eco-friendly motors that meet all the market needs.

## Nidec® UltraFlo™ Cooling Fans

近年、コンピュータや家電製品は加速度的に高性能化し、これらの製品の発熱量は増加の一途をたどっています。ファンモータは、これら製品の冷却に必要な不可欠であり、その活躍分野はますます広がりを見せ、用途も多様化してきました。このような市場動向から、ファンモータにはより高い冷却性能と静粛性が求められています。

Nidec **UltraFlo** シリーズは、従来のファンモータを進化させ、高風量・高静圧・高効率であるとともに低騒音・低振動を実現、地球環境にも配慮した、あらゆる市場ニーズにお応えするファンモータです。

Nidec ロゴは、日本電産(株)の日本国、米国およびその他の国における登録商標または商標です。

Nidec logo is registered trademark or a trademark of Nidec Corporation in Japan, the United States and/or certain other countries.

All for dreams ロゴは、日本電産(株)の日本国における登録商標または米国およびその他の国の商標です。

All for dreams logo is registered trademark of Nidec Corporation in Japan, and a trademark in the United States and/or certain other countries.

Ultra Flo ロゴは、日本電産(株)の日本国における登録商標または米国およびその他の国の商標です。

Ultra Flo logo is registered trademark of Nidec Corporation in Japan, and a trademark in the United States and/or certain other countries.

その他の社名および製品名等は、各社の商標または登録商標です。

Other names and brands may be claimed as the property of others.

# INDEX

型番説明 Explanation of Model Numbers	1
軸流ファンの種類について Axial Flow Fans	2
取り付け穴形状について Types of the Mounting Flange	3
<b>NBFX</b> ファンについて <b>NBFX</b> Fans	4
特殊制御機能について Special Control Functions	5
電氣的共通仕様 Typical Electrical Features	7
標準コネクタ (推奨コネクタ) / 特記事項 Standard Connectors (Nidec's Recommendation) / Special Remarks	8
カスタム品対応について / 環境への取組について / 特定用途について Custom Fans / Environmental Approach / Unintended usage of the products	9
風量の測定方法について How to measure the Air Flow - Static Pressure	10
単位について Unit Notation	11
40×40×10mm Series	12
40×40×28mm Series	13
40×40×56mm Series	14
40×40×56mm Series	15
60×60×15mm Series	16
60×60×25mm Series	17
60×60×38mm Series	18
60×60×38mm Series	19
60×60×38mm Series	20
70×70×15mm Series	21
70×70×25mm Series	22
70×70×38mm Series	23
80×80×15mm Series	24
80×80×25mm Series	25
80×80×38mm Series	26
80×80×38mm Series	27
80×80×38mm Series	28
92×92×25mm Series	29
92×92×32mm Series	30
92×92×32mm Series	31
92×92×38mm Series	32
92×92×38mm Series	33
120×120×38mm Series	34
120×120×38mm Series	35
120×120×38mm Series	36
φ172×150×51mm Series	37
φ172×150×51mm Series	38
φ172×150×51mm Series	39
φ172×51mm Series	40
120×120×32mm Series	41
機種別機能別一覧表 <i>UltraFlo</i> Fans Matrix	43-44
メモ Memo	45-46
日本電産グループ Address Book	47-48

Заказ г.Минск vibeg и тел. +375447581758

# 型番説明 Explanation of Model Numbers

**U**   **40**   **S**   **12**   **B**   **S1**   **A**   **5**   **-**   **01**   **A01**  
 ①   ②   ③   ④   ⑤   ⑥   ⑦   ⑧   ⑨   ⑩

## ① 種類 Type

F	Fan/Heatsink Combination
G	Blower
GW	MIW (motorized impeller wheel)
H	Hybrid - Open Flange
R	DICR - Open Flange
S	DICR - Closed Flange
T	Tube Axial - Open Flange
I	Tube Axial - Single Flange
U	Tube Axial - Closed Flange
V	Vane Axial - Open Flange
W	Vane Axial - Closed Flange
Y	172 mm - Round Housing
X	172 mm - Flat Housing
YV	172 mm - Round Housing with vane
XV	172 mm - Flat Housing with vane

## ② サイズ Size

25	25 mm
30	30 mm
35	35 mm
40	40 mm
42	42 mm
50	50 mm
51	51 mm
59	59 mm
60	60 mm
70	70 mm
76	76 mm
80	80 mm
92	92 mm
93	93 mm
97	97 mm
12	120 mm
17	172 mm

## ③ 厚さ Thickness

U	3 mm
F	4 mm
M	5 mm
N	7 mm
X	10 mm
R	15 mm
G	20 mm
T	25 mm
S	28 mm
B	30 mm
C	32 mm
D	33 mm
E	38 mm
I	48 mm
L	51 mm
W	56 mm
Q	70 mm
K	76 mm
H	80 mm
J	100 mm

## ④ 電圧 Voltage

03	3.3 V
05	5 V
07	7 V
12	12 V
18	18 V
24	24 V
36	36 V
48	48 V

## ⑤ 軸受構造 Bearing Type

B	ボールベアリング	Ball Bearings
D	FDB軸受	FDB
M	<b>NBRX</b> タイプ	<b>NBRX</b> type

## ⑥ 速度 Speed

L	Low
M	Medium
H	High
G	Grand
U	Ultra
S1, S2, S3	Special *
* その他の速度 Others	

## ⑦ 世代 Generation

Sequential A, B, C  
 Reserved for next generation  
 (new motor, core, etc.)  
 Single & Two phase: A, B, C,,,,,  
 Three phase: M, N, P, Q,,,,,

## ⑧ 羽数 Blade Count

羽根枚数(1文字)  
 One Digit for # of blades

10枚	:	A
11枚	:	B
12枚	:	C
:	:	:

DICRファンは、2つのインペラ  
 翼枚数之和を適用する。  
 To use sum of two imp. for DICR.

## ⑨ 回路 Circuit

### 回転速度フィードバック制御有り

#### Feedback Control Design(01-50)

01	Standard
02	Tachometer
03	Locked Rotor Alarm
04	Trip Speed Alarm
05	Tachometer + Locked Rotor Alarm
06	PWM
07	PWM + Tachometer
08	PWM + Locked Rotor Alarm
09	PWM + Trip Speed Alarm
10	Thermal
11	Thermal + Tachometer
12	Thermal + Locked Rotor Alarm
13	Thermal + PWM
14	Thermal + PWM + Tachometer
15	PWM + tach + low tach output under locked rotor condition

### 回転速度フィードバック制御無し

#### Without Feedback Control Design(51-99)

51	Standard
52	Tachometer
53	Locked Rotor Alarm
54	Trip Speed Alarm
55	Tachometer + Locked Rotor Alarm
56	PWM
57	PWM + Tachometer
58	PWM + Locked Rotor Alarm
59	PWM + Trip Speed Alarm
60	Thermal
61	Thermal + Tachometer
62	Thermal + Locked Rotor Alarm
63	Thermal + PWM
64	Thermal + PWM + Tachometer
65	PWM + tach + low tach output under locked rotor condition

## ⑩ 末尾 1 Suffix 1

Customer code + rev.  
 5 Digits Maximum

# 軸流ファンの種類について Axial Flow Fans

**UltraFlo** 軸流ファンでは、用途に応じてご利用いただける三種類のファンをラインナップしております。

## (1) Tube Axial ファン

一般的なファンモータ。軸流ファンの排気流は旋回成分を含んでいるため下図のように排気流が拡散します。Tube Axialファンは広範囲に多くの風を排気することができるため換気冷却に適しています。また低速回転で使用することでデジタル家電やオーディオなどの超低騒音用途にも対応します。

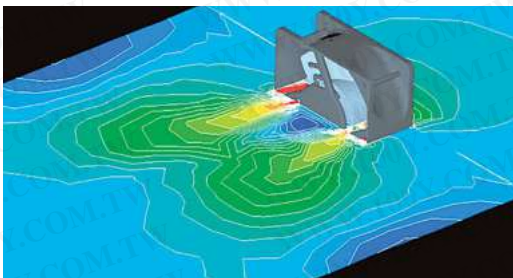

【Tube Axialファンの流速分布イメージ図】

[CG image of the flow velocity distribution of the tube axial fan]

## (2) Vane Axial ファン

排気側に備えた静翼によって排気流の旋回成分を整流し、風の拡散を防ぎます。冷却対象に効率よく風を当てること出来るため、スポット冷却に適しています。また、ファンを直列に連結して使用する場合や複数のファンを並列に並べて使用する場合にも、静翼の整流作用が有効に働くためVane Axialファンが適しています。

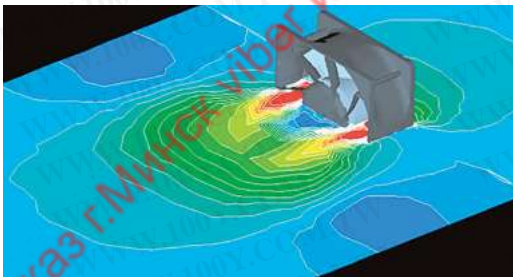

【Vane Axialファンの流速分布イメージ図】

[CG image of the flow velocity distribution of the vane axial fan]

## (3) Hybrid Axial ファン

小型の静翼を持つファンで、Tube AxialファンとVane Axialファンの中間の特性を有します。静翼の本数を最小限に抑えることで、低速から高速まで幅広い用途で使用できるように設計されています。

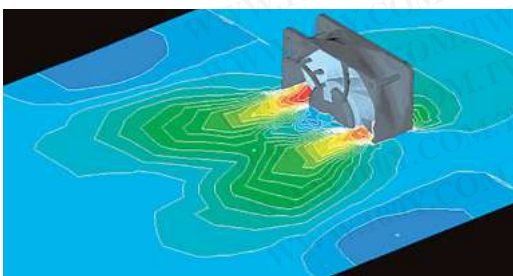

【Hybrid Axialファンの流速分布イメージ図】

[CG image of the flow velocity distribution of the hybrid axial fan]

**UltraFlo** axial fans have a lineup of three types of fans for different areas of usage.

## (1) Tube Axial Fan

The exhaust flow from an axial fan contains swirling flows, which diffuse the exhaust air, as shown in the CG image below. The tube axial fan, a commonly used fan motor capable of exhausting large amounts of wind in wide areas, is suitable for ventilatory cooling. Also, rotating this motor at a low speed accommodates ultra low-noise usage such as digital home appliance and audio equipment.



## (2) Vane Axial Fan

The vane axial fan rectifies swirling exhaust flows with its stator vanes equipped on the exhaust side, and prevents pneumatic diffusion. This motor, which can provide its target with wind efficiently, is suitable for spot cooling. The vane axial fan is also suitable when fans are used concatenated serially or in parallel, when the fans rectify exhaust flows effectively.



## (3) Hybrid Axial Fan

The hybrid axial fan, equipped with small static vanes, possesses characteristics of both tube and vane axial fans. This fan, with the minimum number of static vanes attached, is designed to accommodate a wide variety of low- to high-speed usage.



## 取り付け穴形状について Types of the Mounting Flange

軸流ファンの取り付け穴形状にはフランジタイプと通し穴タイプの2種類があります。

フランジタイプは片側のフランジを使ってネジ締めする場合や、お客様の方でフランジに合うシャーシを設計して頂き、はめあいで使用するのに適しています。

通し穴タイプは通しボルトを使ったネジ締めに適しています。

There are two types in the mounting holes of the DC tube axial fan, open flange type and closed flange type.

Open flange type is useful to screw down the flange or to fit it into the chassis designed by the customer.

Closed flange type is useful for screwing down using the close type bolt.



フランジタイプ  
Open flange



通し穴タイプ  
Closed flange

Заказ г.Минск vibeg и тел. +375447584780 email: minsk17@lut.by

# NBRX™ ファンについて NBRX™ Fans

**NBRX**とは弊社が新規に開発した焼結含油軸受けシステムの名称で、従来の焼結含油軸受けよりも高信頼性を実現した、全く新しい軸受けシステムです。

## 【NBRX ファンの特長】

- ①従来の焼結含油軸受けよりも長寿命化を達成
- ②チップマグネットによる安定した回転体の保持構造を有する

**NBRX** is our company's newly developed, unprecedented oil-impregnated sintered bearing that possesses better reliability than the existing oil-impregnated sintered bearing.

## 【NBRX Fans' characteristics】

- ①It is more durable than the existing oil-impregnated sintered bearing.
- ②It uses a chip magnet that stabilizes its rotating body.

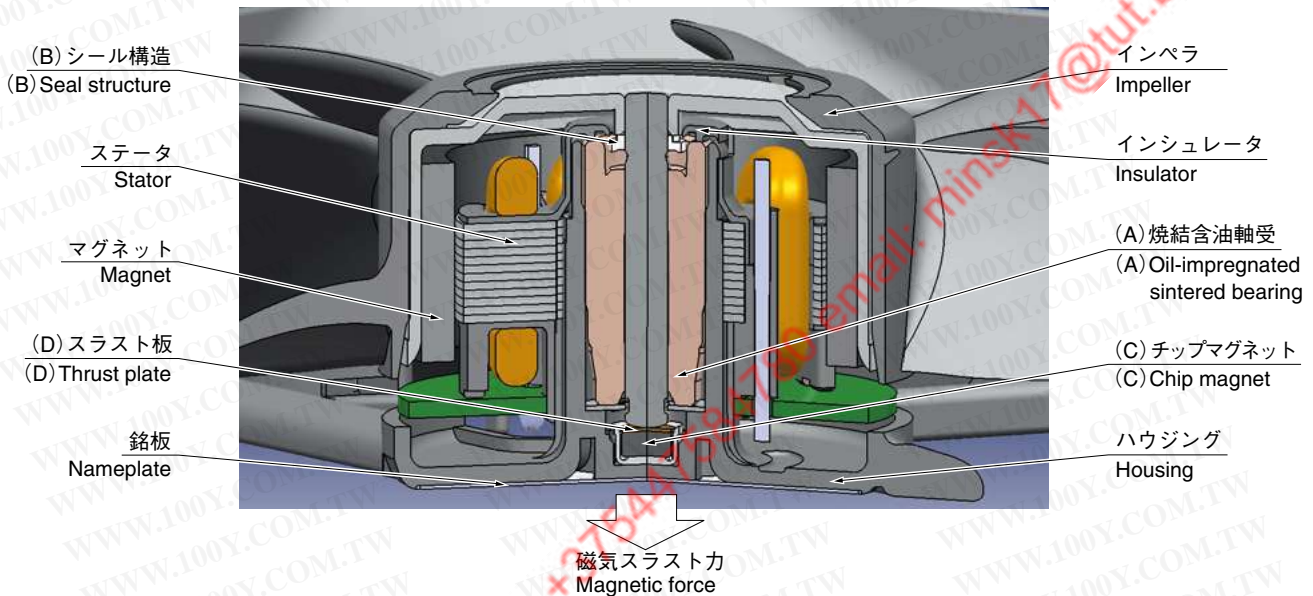

## 【NBRX の技術ポイント】

新規開発品の **NBRX** は以下の新技術によりファン性能の向上を実現しました。

- (A) 長寿命化のための新規開発スリーブ
  - ・耐熱性に優れた低蒸発オイルを使用しオイルの損失を低減 (20%低減)
  - ・スリーブベアリングを大容量化しオイルの含有量を増加
- (B) 潤滑オイルの外部流出を防止するための新規シール構造
  - ・従来のオイル流出防止機構を改良した新シール機構を採用し、更なるオイルシール性を実現
- (C) チップマグネットによる磁気吸引構造
  - ・強い磁気スラスト力で回転体を保持し、高速回転時でも安定かつファンの取付姿勢に制約がない
  - ・ステータ/マグネット間の磁気センターを合わせて磁気振動を低減
- (D) 高摺動材のスラスト板
  - ・耐磨耗性に優れた高摺動樹脂材料を使用
  - ・優れた耐熱性を有し、高速回転、高温環境下での対応が可能

## 【Technical features of NBRX】

The following new technology enhanced the fan's performance in the newly developed product, **NBRX**.

- (A) The newly developed sleeve to enhance the fan's longevity
  - ・ High heat-resistant, vaporization-resistant oil is used to reduce oil loss (by 20%).
  - ・ The size of sleeve bearing has enlarged, accommodating more oil.
- (B) The new seal structure to prevent lubricant leakage
  - ・ A new seal structure, modified from the existing enhanced lubricant leakage prevention feature, was adopted to achieve better oil sealing capability.
- (C) The magnetic aspiration structure with a chip magnet
  - ・ The strong magnetic force retains the fan's rotating body, stabilizing it even in high-speed rotation and yet enabling fan installation from any angle.
  - ・ The magnetic centers of the stator and the magnet are aligned, reducing magnetic vibration.
- (D) The thrust plate made of high-quality sliding material
  - ・ A high abrasion-resistant, high-quality sliding material is used.
  - ・ The plate, highly heat-resistant, performs well under high-speed rotation and high temperature.



# 特殊制御機能について Special Control Functions

## 出力信号、速度制御

### A. 出力信号

ファンの回転状態をファンの外部の装置に知らせるため、下記の信号のいずれかを出力させることができます。出力信号はオープンコレクター出力です。小型の機種では、信号を付加することができない場合があります。

#### (1) 出力信号の種類

##### ① 回転速度信号

ファンの回転速度に比例した周波数のパルス信号を出力します。羽根が一回転する期間に2パルス出力します。装置側でパルスの周波数を監視することでファンの回転速度の低下を知ることができます。

##### ② ロック検出信号

ファンが正常に回転しているときにローレベルになり、羽根がロックされたときハイレベルになります。ファンがロックした状態から再起動する機種では、再起動の動作中にロック検出信号がハイレベルまたはローレベルに切り換わる場合があるのでご注意ください。

##### ③ 反転ロック検出信号

ロック検出信号の逆極性の信号です。

##### ④ 低回転検出信号

正常回転時にローレベルでファンの回転速度が一定値以下に低下した場合にハイレベルになります。標準では定格回転速度の70%の回転速度を閾値とします。前記の出力信号に比べ複雑な制御となるためマイコン機種などハイエンド機種にのみ適用可能です。

##### ⑤ 反転低回転検出信号

低回転検出信号の逆極性の信号です。

#### (2) 接続図

下図を標準とします。

オープンコレクタ形式、プルアップ電圧は最大15V、シンク電流は最大10mAです。ローレベルの出力電圧はシンク電流5mA時、最大0.5Vです。ただし、ホットプラグ対応型の場合最大0.8Vです。ノイズフィルタとして10000pFを付加してください。

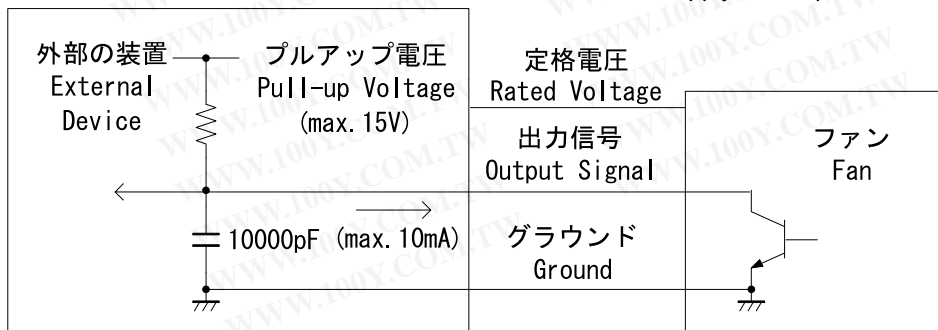

## Output Signals and Speed Control Features

### A. Output Signals

Nidec DC fan models offer output signals, as specified below, that transmit their operating conditions to the external system. The signals are transmitted by open-collector output. Some small-size models may not be able to accommodate such signals.

#### (1) Types of Output Signals

##### ① Tachometer Signal

This signal is a pulse signal transmitted with the frequency in proportion to the fan's operating speed. Two pulses are transmitted per rotation. Monitoring the pulses' frequency at the system enables to know when the fan's operating speed has reduced.

##### ② Locked Rotor Detection Signal

The level of this signal is low when the fan is operating normally, and becomes high when the fan's impeller is locked. Please remember that, in some models that restart with their fans locked, the level of the locked rotor detection signal may switch to high or low during the restart process.

##### ③ Reverse Lock Detection Signal

This signal is the opposite of the locked rotor detection signal.

##### ④ Trip Speed Alarm

The level of this signal becomes high when the fan's speed becomes below a specific value at a low level during normal revolution. With standard fans, the threshold RPM value is 70% of the rotating speed. This control, which is more complex than the previous output signals, is suitable to high-end models only.

##### ⑤ Inverted Trip Speed Alarm

This signal is the opposite of the trip speed alarm.

#### (2) Connection Diagram

In the standard diagram of an open connector type below, the pull-up voltage is maximum 15V, and the minimum sink current is 10mA. The maximum output voltage at the low level is 0.5V when sink current is 5mA. However, the maximum voltage rises up to 0.8V with hot plugging fans. Please apply 10,000pF as a noise filter.

## B. 速度制御

必要に応じてファンの回転速度を変化させることができます。

### (1) 温度センサによる速度制御

サーミスタをファンに内蔵するかファンの外部に取り付け、サーミスタの検出する温度に応じて回転速度を変化させます。温度と回転速度の関係を調整することができます。

### (2) 2速度制御信号による速度制御

ファンの外部の装置からハイレベルまたはローレベルの信号をファンに入力し、この信号でファンの回転速度を2段階に切り替えることができます。2つの回転速度は調整することができます。

### (3) PWM信号による速度制御

ファンの外部の装置からPWM (Pulse Width Modulation) 信号をファンに入力し、PWM信号のデューティー比を変化させてファンの回転速度を変化させることができます。

## C. フィードバック制御

フィードバック制御とは、実際の回転速度と目標の回転速度を比較し、その差によって両者を一致させるような修正動作を行わせるようにしたものです。ファンに掛かる負荷や印加電圧の変動など予期し得ない外乱が加わっても、フィードバックによって有効に修正動作が行われますのでファンの回転速度の精度が改善されます。但し、フィードバック制御機能がある場合とない場合では風量-静圧特性や風量-電流値特性などのパフォーマンスに差異があります。また、フィードバック制御は電源電圧の変化に対しても回転速度に自動修正が掛かりますので電源電圧を変えて回転速度を変えるような用途にはフィードバック制御は適用できませんのでご注意ください。

## D. その他

抵抗を通してファンに電源を供給することでファンの電源電圧を下げ、回転速度を低下させる場合、電源電圧が下がりすぎるとファンの回転が不安定になります。



ファンの電源電圧をPWM制御して(頻繁にオンオフさせて)回転速度を調整することは、ファンの内部に過電圧が発生し電子回路を破壊する原因になります。これらの方法を採用させる場合は弊社にお問い合わせください。

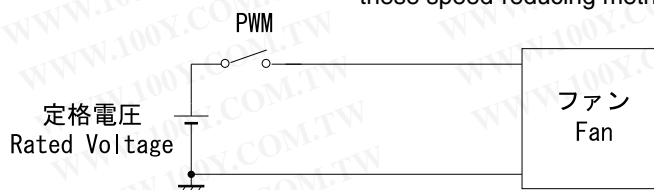

## B. Speed Control

Nidec DC fans' operating speed can be changed as necessary.

### (1) Speed Control by Temperature Sensor

With a thermistor built in or attached outside the fan, its rotating speed can be changed based on the temperature that the thermistor detects. The fan's operating speed can be adjusted based on the temperature that the thermistor detects.

### (2) Speed Control by Dual Speed Control Signal

One can switch the fan's operating speed to high or low by inputting either a high-level or a low-level signal from a device outside the fan. The two speeds are adjustable.

### (3) Speed control by PWM Signal

To change the fan's operating speed, input a PWM (Pulse Width Modulation) from an external device to change the signal's duty cycle.

## C. Feedback control

The feedback control is a function that compares the actual and the target speeds, and makes adjustments to match them. Even when unexpected disturbance such as change in load on the fan and applied voltage occurs, the feedback control effectively makes adjustments, enhancing the accuracy of the fan's rotation speed. However, please remember that, depending on whether the fan has the feedback control function or not, its performance in the air flow - static pressure, the air flow - current value, and other characteristics differs. Also, the feedback control, which automatically adjusts a speed when a power supply voltage changes, cannot be used to change a speed by adjusting a power supply voltage.

## D. Others

When lowering the fan's operating speed by reducing power supply voltage through a resistor, the fan will operate unstably if the voltage drops too low.

In addition, adjusting the fan's operating speed by controlling the fan's power supply voltage with PWM (i.e. by switching on and off the fan frequently) may cause to generate excessive voltage inside the fan, and to destroy its electronic circuit. Please contact us if you adopt any of these speed-reducing methods.

# 電氣的共通仕様 Typical Electrical Features

## 【絶縁階級】

JIS-C-4004 : E種 (120℃)  
(回転電気機械通則)

UL-703 : Class A (105℃)

CSA-C22.2 : Class A (105℃)

DIN IEC380 : Class E (90℃)

VDE-0806 : Class E (90℃)

VDE-0700 : Class E (90℃)

## 【絶縁耐圧】

500V (50/60Hz) 1分間

(注) FANの電源端子又はリード線導体部 (リード線2本を短絡) とフレーム間。

## 【絶縁抵抗】

500Vにて10MΩ以上

(注) FANの電源端子およびリード線導体部 (リード線2本を短絡) とフレーム間。

## 【保護方式】

### ○サーミスタ方式

サーミスタの内部抵抗による発熱を利用したものであり、過電流が流れると内部抵抗が大きくなり、電流を減少させ異常発熱あるいは焼損を防止する方式をいいます。

### ○電流制限保護方式

ファンモータがロックされたり、何らかの原因で回転速度が異常に低くなったりした場合にモータのドライブ電流をカットオフ (遮断) する方式をいいます。この場合、ファンは数秒後に自動的に再起動します。

### ○シャットダウン方式

ファンモータがロックされたり、何らかの原因で回転速度が異常に低くなったりした場合にモータのドライブ電流をカットオフ (遮断) する方式で、カットオフ後、電源を一度OFFしてから、再度ONすると再起動します。

### ○インピーダンスプロテクト方式

ファンモータ巻線固有のインピーダンス (交流抵抗) により、絶縁階級に定められた温度上昇値以下となるよう、モータ巻線を定める方式をいいます。

## 【逆接続】

定格電圧12Vの場合は15Vまで、24Vの場合は30Vまで、また48Vの場合は65Vまで逆接続されても異常が発生しません。

## 【Insulation Class】

JIS-C-4004 : Class E (120℃)

UL-703 : Class A (105℃)

CSA-C22.2 : Class A (105℃)

DIN IEC380 : Class E (90℃)

VDE-0806 : Class E (90℃)

VDE-0700 : Class E (90℃)

## 【Dielectric Strength】

500V (50/60Hz) for 1 minute

Between frame and leads (2 leads are short-circuited) or power source terminal.

## 【Insulation Resistance】

10MΩ min. at 500V

## 【Protection Method】

### ○Thermistor Method

This protection method is based on a special type of thermistor to be used to protect against abnormal temperature rise inside fans. The thermistor to be used is sensitive to heat and if, for some reasons, the temperature inside the fan goes up, then the internal resistance of thermistor becomes larger which limits current to run the fan and controls the temperature inside the fan within a certain designated level and protects the fan from burning out.

### ○Current Limit Method

This method is to cut off the driving current when the fan motor is locked or when the speed of the motor becomes abnormally low for some reason. In such cases, the fan motor automatically will reactivate within several seconds.

### ○Shut Down Method

This method is to cut off the driving current when the fan motor is locked or when the speed of the motor becomes abnormally low for some reason. In such cases, the fan motor can be reactivated by turning it off and back on.

### ○Impedance Method

This method is to control the temperature inside the fan within the specified limit of insulation class of winding wire by designing the coil winding to a certain impedance level.

## 【Reverse Voltage Protection】

The unit will not be damaged by reverse voltage up to 15V for rated voltage of 12V, up to 30V for rated voltage of 24V, or up to 65V for rated voltage of 48V.

## 標準コネクタ (推奨コネクタ) Standard Connectors (Nidec's Recommendation)

コネクタピッチ Connector Pitch	メーカー Manufacturer	ハウジング Housing	コンタクト Contact
1.50mm	日本圧着端子製造(株) J. S. T. Mfg. Co., Ltd	ZHR - *	SZH - 002T - P0.5
2.00mm	日本圧着端子製造(株) J. S. T. Mfg. Co., Ltd	PHR - *	SPH - 002T - P0.5S
	タイコエレクトロニクス アンプ(株) Tyco Electronics AMP K. K.	173977 - *	
2.50mm	日本圧着端子製造(株) J. S. T. Mfg. Co., Ltd	EHR - *	SEH - 001T - P0.6
		XHP - *	SXH - 001T - P0.6
	タイコエレクトロニクス アンプ(株) Tyco Electronics AMP K. K.	171822 - *	170262 - 1
2.54mm	MOLEX INC.	2695 - *	5159 *

注：\*印は極数を示し2極の場合は2、3極は3となります。

コネクタ付きで対応する場合は、コネクタ仕様に合わせたリード線を使用します。

< Remarks > \* mark means the number of pole.

For example, "-2" means 2 poles and "-3" means 3 poles.

In case of responding with connectors, leads adjusted to connectors should be used for fans.

## 特記事項 Special Remarks

- 記載された特性を満足する範囲内で部品等を一部変更する場合があります。
- 保管はできるだけ6ヶ月以内とし高温多湿の所は避けて下さい。
- ブラシレスファンモータはファン内部がコイルとIC等の電子回路で構成されているため、原則的には、電源をPWM制御して使用することはできません。但し、回路的に工夫して使用可能となる場合がありますので事前にご連絡願います。
- 回転信号及び回転停止信号付とする場合は事前に仕様についてご相談下さい。
- 回転信号出力線や2速度制御ファンの制御信号線を誤接続しますと破壊することがありますので注意して下さい。
- 製品改良のため、特性の一部を予告なく変更する場合があります。
- Components to be used for each model of fans listed in this catalog may be changed for various reasons within the scope but will not affect the major characteristic parameters of fans specified.
- It is generally required that a storage period of fans without any use be limited to six (6) months maximum. Storage of fans in high temperature and or high humidity environment should be avoided.
- In case fans are to be used with PWM control, we should be consulted in advance.
- In case fans are to be controlled with speed signal or lock signal, we should be consulted in advance in order to finalize the specifications to be applied.
- In case of fans with speed signal and/or two speed control device, special attention should be paid not to misconnect the lead wires of each device since misconnection could possibly result in serious damage to the fans.
- We may change some of the major characteristic parameters of fans without any notice in order to improve the total level of the fan characteristics.

## カスタム品対応について Custom Fans

貴社装置に合わせた下記のようなカスタム設計を承ります。

- (1) 装置に適した羽根・ハウジングの設計
- (2) 防湿・防錆・防塵タイプ
- (3) 放熱フィン（ヒートシンク）付ファンモータの設計
- (4) その他のカスタム設計

Nidec designs custom fans per your system requirements. The four topics below are required for custom fans.

- (1) Design of impeller and housing which will fit your system requirements.
- (2) Environmentally protected fans. (Safe from humidity, rust or dust.)
- (3) Design of fan motors which radiate heat (Heat sink).
- (4) Nidec is constantly looking at new specifications and requirements to improve our product lines.



## 環境への取組について Environmental Approach

2006年7月1日、EU（欧州連合）において、電気電子機器に含まれる特定有害物質の使用制限に関するRoHS指令が施行されました。当社では、特定有害物質である鉛、カドミウム、水銀、六価クロム、特定臭素系難燃剤であるPBB（ポリ臭素化ジフェニル）、PBDE（ポリ臭素化ジフェニルエーテル）について、お客様のご要求によりRoHS指令に適合していない製品を除き、RoHS指令への対応は完了しております。

また、法規制だけでなく、PVC（ポリ塩化ビニル）やハロゲン等の環境に影響する物質の削減廃止にも自主的に取り組んでおります。

The RoHS Directive, which restricts the use of specific hazardous substances contained in electric and electronic devices, came into effect in the EU (European Union) on July 01, 2006. Based on the Directive, our company has already restricted the use of specific hazardous substances (lead, cadmium, mercury, and hexavalent cadmium) and specific brominated flame retardants (polybrominated biphenyl (PBB) and polybrominated diphenyl ether (PBDE)) on our products except for the ones not in compliance with the Directive due to our customers' requests. In addition to complying with relevant laws and regulations, we actively try to reduce and abolish the use of polyvinyl chloride (PVC), halogen and other substances that harm the environment.

## 特定用途について Unintended usage of the products

本資料に掲載されている製品は、一般的な電子機器（コンピュータ、OA機器、通信機器、家電製品、計測機器等）に使用されることを意図して設計・製造されております。特別に高い品質・信頼性が要求され、その故障や誤作動が人の生命、身体への損害又はその他の重大な損害の発生に関わるような機器（原子力制御機器、航空宇宙機器、輸送機器（自動車、電車、船舶等）、交通信号機器、燃料制御、医療機器、各種安全装置など）にこれらの製品を使用すること（以下“特定用途”という）は意図されていませんし、保証もされておられません。特定用途へのご使用を検討される際は、事前に弊社営業窓口までご連絡下さいますようお願い致します。

The products described in this document are designed and manufactured based on the intention that they will be used for general electronic devices and equipment (e.g. computers, office automation equipment, communications devices, home appliances and measuring equipment). This usage requires a specially high level of quality and reliability of the products, which are neither intended nor guaranteed to be used for any equipment whose failure or malfunction would cause damage to the human life or body or any other serious damage (e.g. nuclear power control devices, aerospace instrument, transportation machines (e.g. cars, trains and ships), traffic signals, fuel controllers, medical equipment and various safety devices). Please contact our sales personnel for any unintended usage of the products. Thank you.

# 風量の測定方法について How to measure the Air Flow - Static Pressure

## 【風量 - 静圧特性 (P - Q カーブ)】

ファンの風量-静圧特性図は、吸い込み口及び吹き出し口にかかる圧力の損失による風量と静圧の関係を曲線で表したものです。

圧力による損失(静圧)が0の場合を最大風量、圧力損失(静圧)が最大の場合を最大静圧と呼びます。

## 【P - Q カーブの測定方法】

AMCA STANDARD 210 (85) に基づいたダブルチャンバー方式を採用した測定装置を用い、全ての機種 of 測定を行っております。

本方式は JIS B 8330 (送風機検査及び試験方式) で規定された風量測定では計測が難しい小風量に対して同付属の解説の中で、ダブルチャンバー方式を使用してもよいとの記述があり、このため JIS にも準拠しています。

### ○ダブルチャンバー

独立した2つの風洞の間に風量測定用ノズル(以降ノズルと呼ぶ)があり、測定されるファンは装置の入り口に取り付けられます。

ノズルを通過する風量は、ノズル前後の圧力差を測定し、これに温度気圧補正を行うことにより算出され、これと同時にファンより発生した静圧も測定することが出来ます。補助ブローアは、ファンの前後の圧力差が0の場合に風量の測定を可能にするため、ノズルの前後に圧力差を生じさせる役割をします。

### ○測定方法

はじめにノズルを全閉状態にし、測定ファン側の風洞を密閉状態にすることにより、最大静圧を測定します。次に、ノズルを解放し、補助ブローア及びダンパーを自動制御して圧力損失0の環境を作り、ノズル直径及び風洞間の圧力差より最大風量を算出します。この計測された最大風量から指定された測定ポイント数(弊社では10ポイントが標準)に最大風量を除算分割し、補助ブローア及びダンパーを用いその分割された風量状態を作りだし、風量、静圧を測定します。この10点のポイントをつないだものが風量-静圧特性図となります。

この測定はすべてパソコンの自動制御で行い、風量、静圧の値についてもパソコンにて演算処理します。

## 【Air Flow - Static Pressure characteristic (P - Q Curve)】

Fans air flow - static pressure characteristic diagram is the curve line which shows the relationship of the air flow and the static pressure caused by the pressure damage on the inlet and the outlet of the fan.

Maximum air flow is the statement when there is no pressure damage (static pressure = 0). Maximum static pressure is named when the pressure damage (static pressure) is at its maximum.

## 【How to measure the P - Q Curve】

All of the models are measured by the equipment adopting the Double Chamber based on AMCA STANDARD 210(85). This method is qualified to JIS. The reason for this is that there is evidence of being able to use the Double Chamber method in the interpretation written below. This interpretation introduce the way to measure the small air flow that has difficulty in calculation and its method is regulated by JIS B 8830 (adverse wind machine examination and testing methods).

### ○Double Chamber

The fan which will be examined is placed at the entrance of the equipment between the two independent air flow measuring nozzles. The air flow going through the nozzle is calculated by measuring the gap of the pressure between the front and the back of the nozzle. The static pressure caused by the fan can be measured at the same time. The assistance blower has the role of making the gap of pressure between the front and the back of the nozzle to measure the air flow when there are no difference in the pressure between the front and the back of the fan.

### ○Measuring Method

Firstly, shut all of the nozzles and measure the maximum static pressure by shutting down the air hole fixed at the side of the measuring fan. Secondly, release the nozzle, make the environment of no pressure damage by automatically controlling the assistance blower and the damper. Then calculate the maximum air flow from the gap of the pressure between the air hole and the diameter of the nozzle. Measure the air flow and the static pressure by dividing the measured point (10 points is the standard in our company). This is appointed by measuring the maximum air flow and make the air flow statement of the divided number using the assistance blower or the dumber. Air flow - static pressure dialog is the thing which these 10 points are connected.

These measurements are arranged by the automatic control of the computer and the air flow - static pressure amount is arranged by the computers processor.

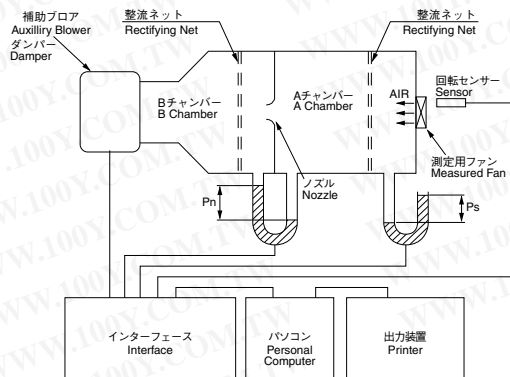

# 単位について Unit Notation

【新旧単位比較表 Old & New unit comparative table】

①新しい呼び方 New designation	SI単位による表記 Notation by SI unit	②従来の呼び方 Conventional designation	従来表記 Conventional notation	②から①への変換 Translation from ② to ①
質量 (MASS)	g	重量 (NET WEIGHT)	g	—
電圧 (VOLTAGE)	V	電圧 (VOLTAGE)	V	—
電流値 (CURRENT)	A	電流値 (CURRENT)	A	—
消費電力 (CONSUMING POWER)	W	消費電力 (CONSUMING POWER)	W	—
回転速度 (RATED SPEED)	min <sup>-1</sup>	回転数 (RATED SPEED)	rpm	× 1
風量 (AIR FLOW)	m <sup>3</sup> /min	風量 (AIR FLOW)	m <sup>3</sup> /min	—
静圧 (STATIC PRESSURE)	Pa	静圧 (STATIC PRESSURE)	mmH <sub>2</sub> O, mmAq	× 9.8067
騒音 (SOUND LEVEL)	dB(A)	騒音 (SOUND LEVEL)	dB(A)	—
温度 (TEMPERATURE)	°C	温度 (TEMPERATURE)	°C	—

【風量の換算表 Air Flow conversion table】

m <sup>3</sup> /min	CFM	L/s	L/min
1	3.531 × 10	1.666 × 10	1 × 10 <sup>3</sup>
2.831 × 10 <sup>-2</sup>	1	4.720 × 10 <sup>-1</sup>	2.831 × 10
6 × 10 <sup>-2</sup>	2.118	1	6 × 10
1 × 10 <sup>-3</sup>	3.531 × 10 <sup>-2</sup>	1.666 × 10 <sup>2</sup>	1

【圧力(静圧)の換算表 Static Pressure conversion table】

Pa (= N/m <sup>2</sup> )	mmH <sub>2</sub> O = mmAq	inchH <sub>2</sub> O = inchAq	mmHg	kgf/cm <sup>2</sup>
1	1.0197 × 10 <sup>-1</sup>	4.0146 × 10 <sup>-3</sup>	7.5006 × 10 <sup>-3</sup>	1.0197 × 10 <sup>-5</sup>
9.8067	1	3.9370 × 10 <sup>-2</sup>	7.3559 × 10 <sup>-2</sup>	1 × 10 <sup>-4</sup>
2.4909 × 10 <sup>2</sup>	2.54 × 10	1	1.8682	2.54 × 10 <sup>-3</sup>
1.3332 × 10 <sup>2</sup>	1.3619 × 10	5.3618 × 10 <sup>-1</sup>	1	1.3595 × 10 <sup>-3</sup>
9.8067 × 10 <sup>4</sup>	1 × 10 <sup>4</sup>	3.9370 × 10 <sup>2</sup>	7.3656 × 10 <sup>2</sup>	1

# 40×40×10mm Series



使用材料/  
ハウジング: プラスチック (UL:V-0)  
インペラー: プラスチック (UL:V-0)  
軸受構造/ **NBRX**タイプ  
保護方法/電流制限  
使用温度範囲/−10°C~70°C  
質量/20g

MATERIAL/  
HOUSING: Plastic (UL:V-0)  
IMPELLER: Plastic (UL:V-0)  
BEARING/ **NBRX** Type  
PROTECTION/Current limit  
OPERATING TEMP/−10°C~70°C  
MASS/20g

## ■外形図 External Dimensions

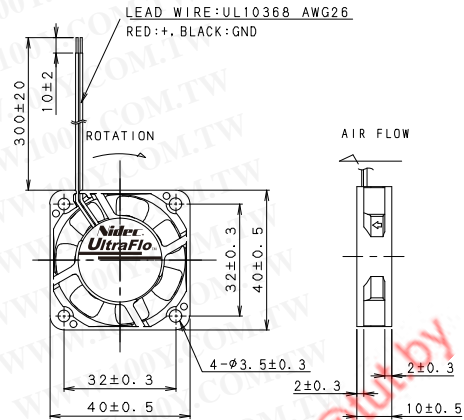

## ■取り付け穴参考寸法 Panel Out - T7

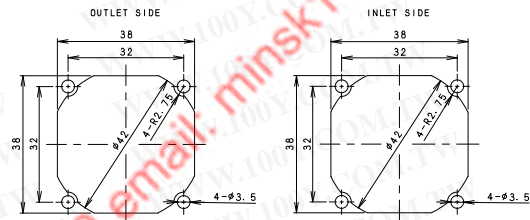

## ■特性 Major Characteristic Parameters

●フィードバック制御無し Without Feedback Control Design

Model	Rated Voltage	Operating Voltage range	Rated Current	Maximum Air Flow		Maximum Static Pressure		Rated Input Power	Sound Level	Rated Speed
	V	V	A	m <sup>3</sup> /min	CFM	Pa	inchH <sub>2</sub> O	W	dB (A)	min <sup>-1</sup>
U40X05MLZ7-5*	5	4.25~5.75	0.10	0.11	3.88	20	0.08	0.50	14.5	5000
U40X05MMZ7-5*	5	4.25~5.75	0.17	0.15	5.30	34	0.14	0.85	21.0	6500
U40X05MHZ7-5*	5	4.25~5.75	0.23	0.19	6.71	47	0.19	1.15	25.5	8000
U40X12MLZ7-5*	12	7.0~13.8	0.05	0.11	3.88	20	0.08	0.60	14.5	5000
U40X12MMZ7-5*	12	7.0~13.8	0.07	0.15	5.30	34	0.14	0.84	21.0	6500
U40X12MHZ7-5*	12	7.0~13.8	0.10	0.19	6.71	47	0.19	1.20	25.5	8000

(注) データは定格電圧での代表特性です。  
Sound Levelは吸込側表面から1mにて測定した値です。  
電源PWMは保証外とします。  
電源の電圧リップルは定格電圧の±5%以下とします。  
上記以外の定格電圧については、個別にお問い合わせ下さい。

(Note) The data shows typical value at rated voltage.  
Sound Level is measured at the distance of one(1)meter from the axis of fan intake.  
Insurance does not apply to power supply PWM.  
The range of voltage ripples for power supply is ±5%.  
Contact us on any rated voltage not listed above.

## ■特性グラフ P-Q Curve

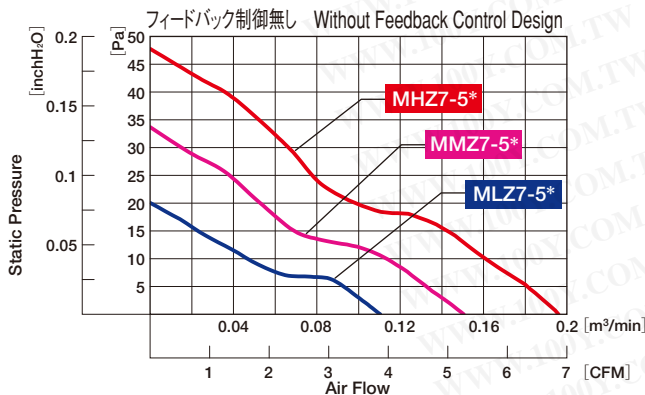



# 40×40×28mm Series



使用材料/  
ハウジング: プラスチック (UL:V-0)  
インペラー: プラスチック (UL:V-0)  
軸受構造/ボールベアリング  
保護方法/電流制限  
使用温度範囲/−10°C~70°C  
質量/50g  
\*フレンジタイプも対応可能です。

MATERIAL/  
HOUSING: Plastic (UL:V-0)  
IMPELLER: Plastic (UL:V-0)  
BEARING/ Ball Bearings  
PROTECTION/ Current limit  
OPERATING TEMP/ −10°C~70°C  
MASS/ 50g  
\* Open flange type is also available.

## ■外形図 External Dimensions

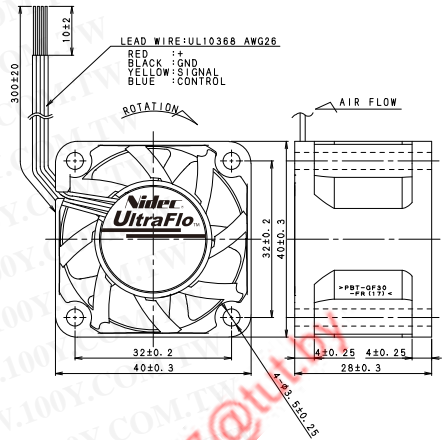

## ■取り付け穴参考寸法 Panel Out - Cuts

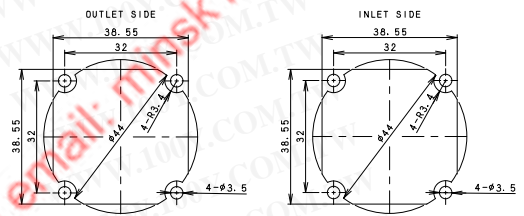

## ■特性 Major Characteristic Parameters

### ●フィードバック制御有り Feedback Control Design

Model	Rated Voltage	Operating Voltage range	Rated Current	Maximum Air Flow		Maximum Static Pressure		Rated Input Power	Sound Level	Rated Speed
	V	V	A	m <sup>3</sup> /min	CFM	Pa	inchH <sub>2</sub> O	W	dB (A)	min <sup>-1</sup>
W40S12BLA5-0*	12	7.0~13.8	0.10	0.28	9.9	74	0.30	1.20	31.5	7000
W40S12BMA5-0*	12	7.0~13.8	0.12	0.31	10.9	111	0.45	1.44	34.5	8500
W40S12BHA5-0*	12	7.0~13.8	0.17	0.42	14.8	155	0.62	2.04	40.0	10000
W40S12BGA5-0*	12	7.0~13.8	0.40	0.60	21.2	305	1.23	4.80	51.0	14500
W40S12BUA5-0*	12	7.0~13.8	0.55	0.67	23.7	400	1.61	6.60	53.0	16000
W40S12BS4A5-0*	12	7.0~13.8	0.73	0.75	26.5	475	1.91	8.76	55.0	18000

### ●フィードバック制御無し Without Feedback Control Design

Model	Rated Voltage	Operating Voltage range	Rated Current	Maximum Air Flow		Maximum Static Pressure		Rated Input Power	Sound Level	Rated Speed
	V	V	A	m <sup>3</sup> /min	CFM	Pa	inchH <sub>2</sub> O	W	dB (A)	min <sup>-1</sup>
W40S12BLA5-5*	12	7.0~13.8	0.10	0.28	9.9	72	0.29	1.20	31.5	7000
W40S12BMA5-5*	12	7.0~13.8	0.12	0.31	10.9	101	0.41	1.44	34.5	8500
W40S12BHA5-5*	12	7.0~13.8	0.17	0.42	14.8	145	0.58	2.04	40.0	10000
W40S12BGA5-5*	12	7.0~13.8	0.40	0.60	21.2	305	1.23	4.80	51.0	14500
W40S12BUA5-5*	12	7.0~13.8	0.55	0.67	23.7	375	1.51	6.60	53.0	16000
W40S12BS4A5-5*	12	7.0~13.8	0.73	0.75	26.5	465	1.80	8.76	55.0	18000

(注) データは定格電圧での代表特性です。  
Sound Levelは吸込側表面から1mにて測定した値です。  
電源PWMは保証外とします。  
電源の電圧リップルは定格電圧の±5%以下とします。  
上記以外の定格電圧については、個別にお問い合わせ下さい。

(Note) The data shows typical value at rated voltage.  
Sound Level is measured at the distance of one(1)meter from the axis of fan intake.  
Insurance does not apply to power supply PWM.  
The range of voltage ripples for power supply is ±5%.  
Contact us on any rated voltage not listed above.

## ■特性グラフ P-Q Curve

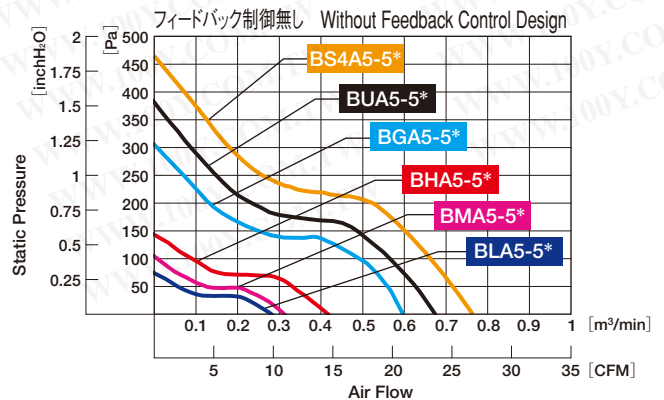
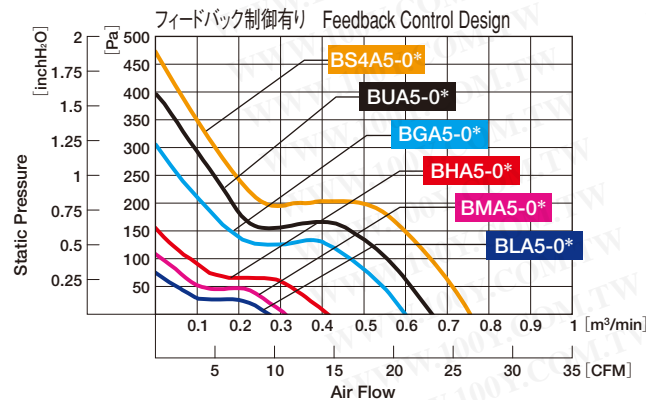

# 40×40×56mm Series



## ■外形図 External Dimensions

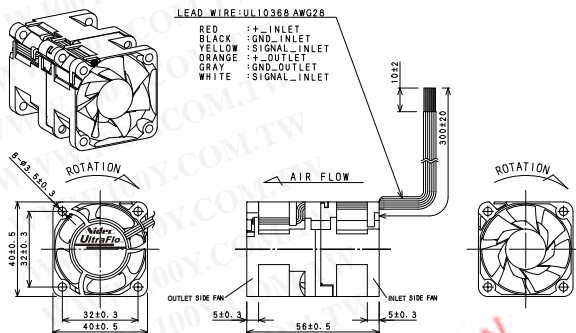

## ■取り付け穴参考寸法 Panel Out - Cuts

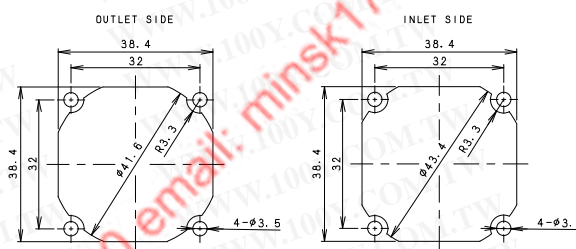

使用材料/  
ハウジング: プラスチック (UL:V-0)  
インペラー: プラスチック (UL:V-0)  
軸受構造/ボールベアリング  
保護方法/電流制限  
使用温度範囲/−10°C~70°C  
質量/90g

MATERIAL/  
HOUSING: Plastic (UL:V-0)  
IMPELLER: Plastic (UL:V-0)  
BEARING/ Ball Bearings  
PROTECTION/ Current limit  
OPERATING TEMP/ −10°C~70°C  
MASS/ 90g

## ■特性 Major Characteristic Parameters

### ●フィードバック制御有り Feedback Control Design

Model	Rated Voltage	Operating Voltage range	Rated Current	Maximum Air Flow		Maximum Static Pressure		Rated Input Power	Sound Level	Rated Speed
	V	V	A	m <sup>3</sup> /min	CFM	Pa	inchH <sub>2</sub> O	W	dB (A)	min <sup>-1</sup>
R40W12BHAC-0*	12	7.0~13.8	1.10	0.78	27.5	337	1.36	13.2	59.5	13800/12300
R40W12BGAC-0*	12	7.0~13.8	1.75	0.92	32.5	485	1.95	21.0	64.0	16000/14500

### ●フィードバック制御無し Without Feedback Control Design

Model	Rated Voltage	Operating Voltage range	Rated Current	Maximum Air Flow		Maximum Static Pressure		Rated Input Power	Sound Level	Rated Speed
	V	V	A	m <sup>3</sup> /min	CFM	Pa	inchH <sub>2</sub> O	W	dB (A)	min <sup>-1</sup>
R40W12BHAC-5*	12	7.0~13.8	1.10	0.78	27.5	430	1.73	13.2	59.5	13800/12300
R40W12BGAC-5*	12	7.0~13.8	1.75	0.92	32.5	600	2.41	21.0	64.0	16000/14500

(注) データは定格電圧での代表特性です。  
Sound Levelは吸込側表面から1mにて測定した値です。  
電源PWMは保証外とします。  
電源の電圧リップルは定格電圧の±5%以下とします。  
上記以外の定格電圧については、個別にお問い合わせ下さい。

(Note) The data shows typical value at rated voltage.  
Sound Level is measured at the distance of one(1) meter from the axis of fan intake.  
Insurance does not apply to power supply PWM.  
The range of voltage ripples for power supply is ±5%.  
Contact us on any rated voltage not listed above.

## ■特性グラフ P-Q Curve

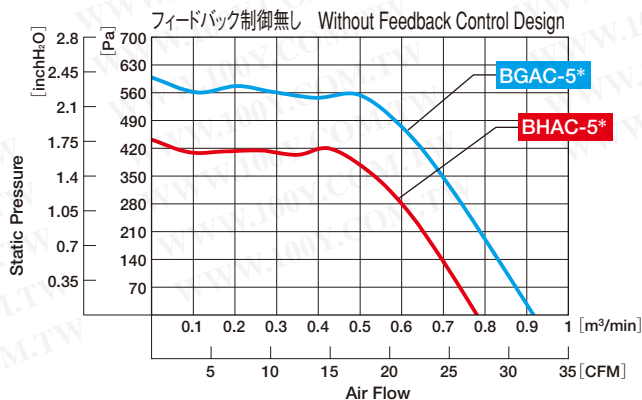
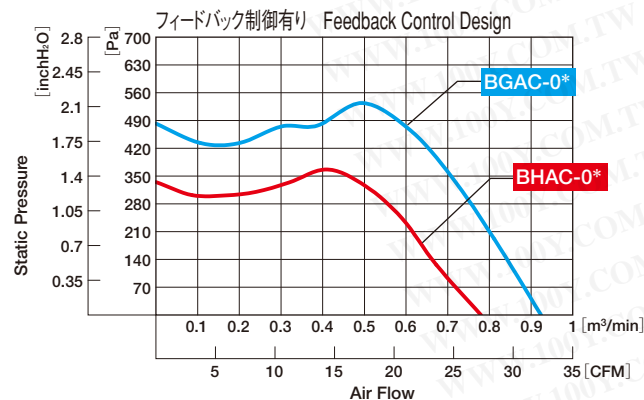

# 40×40×56mm Series



使用材料/  
ハウジング: プラスチック (UL:V-0)  
インペラー: プラスチック (UL:V-0)  
軸受構造/ボールベアリング  
保護方法/電流制限  
使用温度範囲/−10°C~70°C  
質量/97g

MATERIAL/  
HOUSING: Plastic (UL:V-0)  
IMPELLER: Plastic (UL:V-0)  
BEARING/ Ball Bearings  
PROTECTION/ Current limit  
OPERATING TEMP/ −10°C~70°C  
MASS/ 97g

## 外形図 External Dimensions

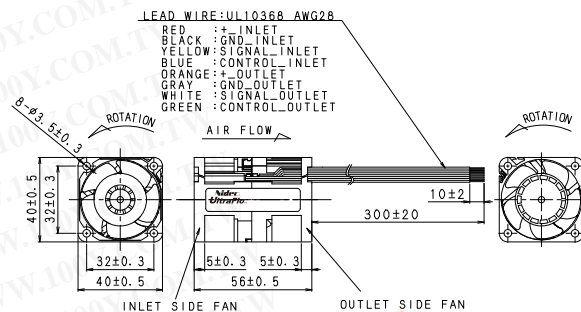

## 取り付け穴参考寸法 Panel Out - Cuts

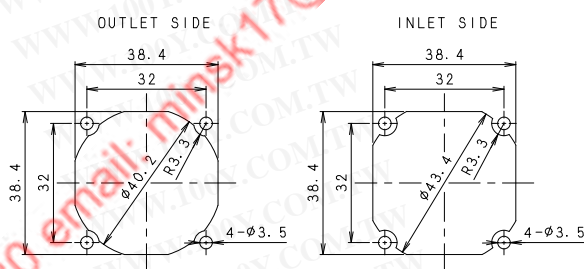

## 特性 Major Characteristic Parameters

### ●フィードバック制御有り Feedback Control Design

Model	Rated Voltage	Operating Voltage range	Rated Current	Maximum Air Flow		Maximum Static Pressure		Rated Input Power	Sound Level	Rated Speed
	V	V	A	m <sup>3</sup> /min	CFM	Pa	inchH <sub>2</sub> O	W	dB (A)	min <sup>-1</sup>
R40W12BHCA-0*	12	7.0~13.8	0.95	0.72	25.4	541	2.17	11.4	60.0	18000/13450
R40W12BGCA-0*	12	7.0~13.8	1.32	0.8	28.2	629	2.52	15.8	64.0	19200/17200

### ●フィードバック制御無し Without Feedback Control Design

Model	Rated Voltage	Operating Voltage range	Rated Current	Maximum Air Flow		Maximum Static Pressure		Rated Input Power	Sound Level	Rated Speed
	V	V	A	m <sup>3</sup> /min	CFM	Pa	inchH <sub>2</sub> O	W	dB (A)	min <sup>-1</sup>
R40W12BHCA-5*	12	7.0~13.8	0.95	0.72	25.4	554	2.22	11.4	60.0	18000/13450
R40W12BGCA-5*	12	7.0~13.8	1.32	0.8	28.2	648	2.60	15.8	64.0	19200/17200

(注) データは定格電圧での代表特性です。  
Sound Levelは吸込側表面から1mにて測定した値です。  
電源PWMは保証外とします。  
電源の電圧リップルは定格電圧の±5%以下とします。  
上記以外の定格電圧については、個別にお問い合わせ下さい。

(Note) The data shows typical value at rated voltage.  
Sound Level is measured at the distance of one(1)meter from the axis of fan intake.  
Insurance does not apply to power supply PWM.  
The range of voltage ripples for power supply is ±5%.  
Contact us on any rated voltage not listed above.

## 特性グラフ P-Q Curve

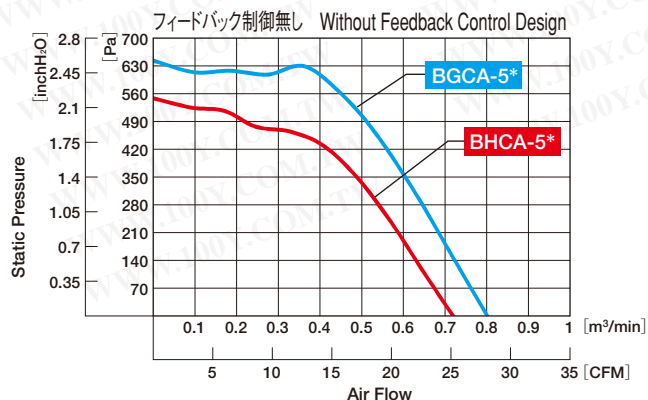
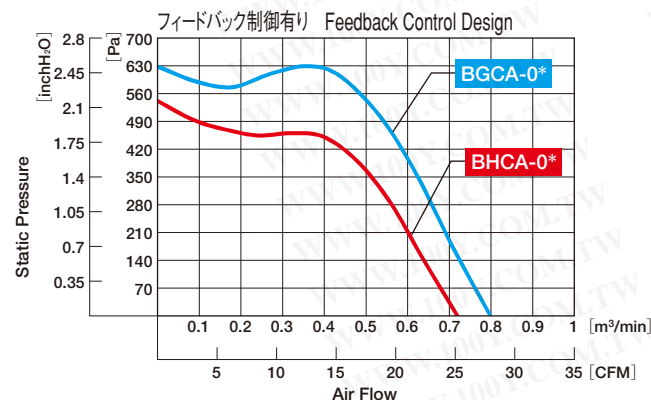

# 60×60×15mm Series



使用材料/ ハウジング: プラスチック (UL:V-0) インペラー: プラスチック (UL:V-0)	<b>MATERIAL</b> / HOUSING: Plastic (UL:V-0) IMPELLER: Plastic (UL:V-0)
軸受構造/ <b>NBRX</b> タイプ	<b>BEARING</b> / <b>NBRX</b> Type
保護方法/電流制限	<b>PROTECTION</b> /Current limit
使用温度範囲/−10℃~70℃	<b>OPERATING TEMP</b> /−10℃~70℃
質量/40g	<b>MASS</b> /40g

## ■外形図 External Dimensions

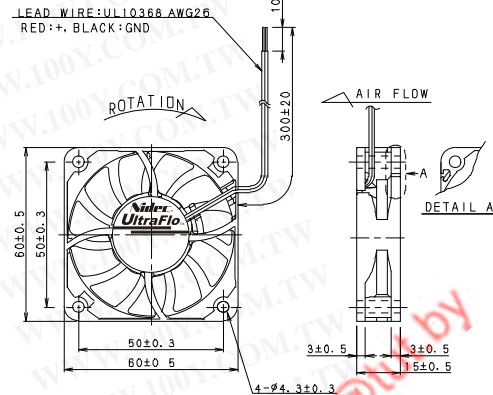

## ■取り付け穴参考寸法 Panel Out - Cuts

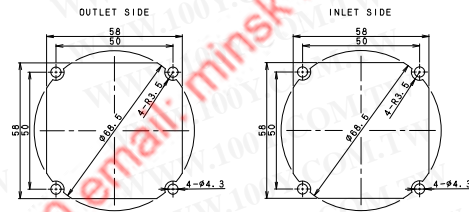

## ■特性 Major Characteristic Parameters

●フィードバック制御無し Without Feedback Control Design

Model	Rated Voltage	Operating Voltage range	Rated Current	Maximum Air Flow		Maximum Static Pressure		Rated Input Power	Sound Level	Rated Speed
	V	V	A	m <sup>3</sup> /min	CFM	Pa	inchH <sub>2</sub> O	W	dB (A)	min <sup>-1</sup>
U60R12MLAB-5*	12	7.0~13.8	0.05	0.35	12.4	13	0.05	0.60	17.0	2400
U60R12MMAB-5*	12	7.0~13.8	0.09	0.48	16.9	22	0.09	1.08	25.0	3300
U60R12MHAB-5*	12	7.0~13.8	0.12	0.56	19.8	28	0.11	1.44	29.0	3800
U60R12MGAB-5*	12	7.0~13.8	0.17	0.64	22.6	37	0.15	2.04	33.0	4300
U60R12MUAB-5*	12	7.0~13.8	0.22	0.76	26.8	52	0.21	2.64	36.5	5000

(注) データは定格電圧での代表特性です。  
Sound Levelは吸込側表面から1mにて測定した値です。  
電源PWMは保証外とします。  
電源の電圧リップルは定格電圧の±5%以下とします。  
上記以外の定格電圧については、個別にお問い合わせ下さい。

(Note) The data shows typical value at rated voltage.  
Sound Level is measured at the distance of one(1)meter from the axis of fan intake.  
Insurance does not apply to power supply PWM.  
The range of voltage ripples for power supply is ±5%.  
Contact us on any rated voltage not listed above.

## ■特性グラフ P-Q Curve

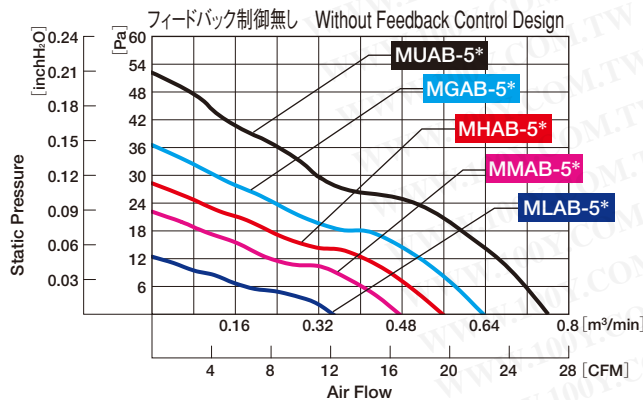

# 60×60×25mm Series



使用材料/  
ハウジング: プラスチック (UL:V-0)  
インペラー: プラスチック (UL:V-0)  
軸受構造/ **NBRX**タイプ  
保護方法/ 電流制限  
使用温度範囲/ -10°C~70°C  
質量/ 80g

**MATERIAL**/  
HOUSING: Plastic (UL:V-0)  
IMPELLER: Plastic (UL:V-0)  
**BEARING**/ **NBRX** Type  
**PROTECTION**/ Current limit  
**OPERATING TEMP**/ -10°C~70°C  
**MASS**/ 80g

## 外形図 External Dimensions

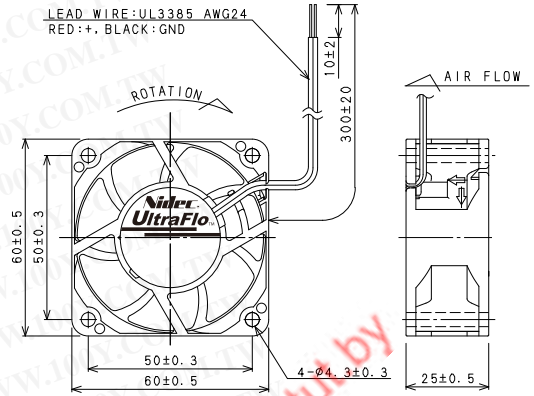

## 取り付け穴参考寸法 Panel Out - Cuts

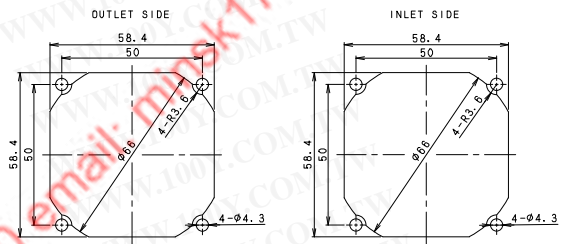

## 特性 Major Characteristic Parameters

●フィードバック制御無し Without Feedback Control Design

Model	Rated Voltage	Operating Voltage range	Rated Current	Maximum Air Flow		Maximum Static Pressure		Rated Input Power	Sound Level	Rated Speed
	V	V	A	m <sup>3</sup> /min	CFM	Pa	inchH <sub>2</sub> O	W	dB (A)	min <sup>-1</sup>
U60T12MMA7-5*	12	7.0~13.8	0.06	0.32	11.4	17	0.07	0.72	13.0	2400
U60T12MHA7-5*	12	7.0~13.8	0.09	0.44	15.4	30	0.12	1.08	22.5	3200
U60T12MGA7-5*	12	7.0~13.8	0.11	0.54	19.1	45	0.18	1.32	29.5	3900
U60T12MUA7-5*	12	7.0~13.8	0.16	0.65	22.8	61	0.24	1.92	32.5	4600
U60T12MS1A7-5*	12	7.0~13.8	0.21	0.76	26.8	79	0.32	2.52	37.0	5400

(注) データは定格電圧での代表特性です。  
Sound Levelは吸込側表面から1mにて測定した値です。  
電源PWMは保証外とします。  
電源の電圧リップルは定格電圧の±5%以下とします。  
上記以外の定格電圧については、個別にお問い合わせ下さい。

(Note) The data shows typical value at rated voltage.  
Sound Level is measured at the distance of one(1)meter from the axis of fan intake.  
Insurance does not apply to power supply PWM.  
The range of voltage ripples for power supply is ±5%.  
Contact us on any rated voltage not listed above.

## 特性グラフ P-Q Curve

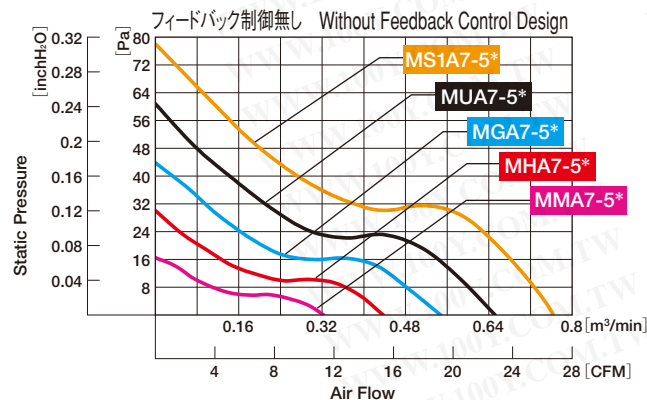

# 60×60×38mm Series



使用材料/  
ハウジング: プラスチック (UL:V-0)  
インペラー: プラスチック (UL:V-0)  
軸受構造/ボールベアリング  
保護方法/電流制限  
使用温度範囲/−10℃~70℃  
質量/120g

MATERIAL/  
HOUSING: Plastic (UL:V-0)  
IMPELLER: Plastic (UL:V-0)  
BEARING/ Ball Bearings  
PROTECTION/ Current limit  
OPERATING TEMP/ −10℃~70℃  
MASS/ 120g

## 外形図 External Dimensions

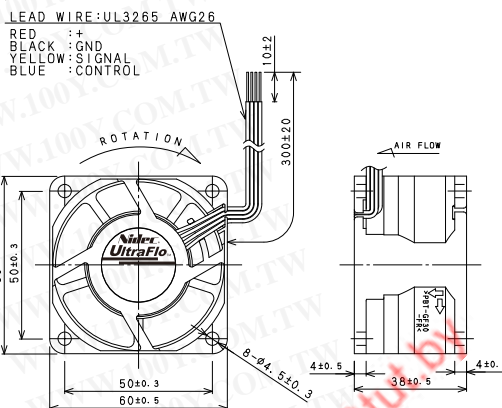

## 取り付け穴参考寸法 Panel Out - Cuts

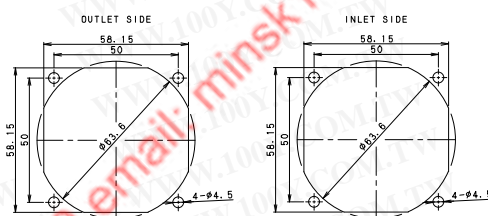

## 特性 Major Characteristic Parameters

### ●フィードバック制御有り Feedback Control Design

Model	Rated Voltage	Operating Voltage range	Rated Current	Maximum Air Flow		Maximum Static Pressure		Rated Input Power	Sound Level	Rated Speed
	V	V	A	m <sup>3</sup> /min	CFM	Pa	inchH <sub>2</sub> O	W	dB (A)	min <sup>-1</sup>
T60E12BLA5-0*	12	7.0~13.8	0.55	1.25	44.1	210	0.84	6.60	48.0	8000
T60E12BHA5-0*	12	7.0~13.8	1.20	1.65	58.3	370	1.49	14.40	55.0	10500
T60E12BUA5-0*	12	7.0~13.8	2.30	2.05	72.4	555	2.23	27.60	60.0	13000

### ●フィードバック制御無し Without Feedback Control Design

Model	Rated Voltage	Operating Voltage range	Rated Current	Maximum Air Flow		Maximum Static Pressure		Rated Input Power	Sound Level	Rated Speed
	V	V	A	m <sup>3</sup> /min	CFM	Pa	inchH <sub>2</sub> O	W	dB (A)	min <sup>-1</sup>
T60E12BLA5-5*	12	7.0~13.8	0.55	1.25	44.1	210	0.84	6.58	48.0	8000
T60E12BHA5-5*	12	7.0~13.8	1.20	1.65	58.3	380	1.53	14.40	55.0	10500
T60E12BUA5-5*	12	7.0~13.8	2.30	2.05	72.4	555	2.23	27.60	60.0	13000

(注) データは定格電圧での代表特性です。  
Sound Levelは吸込側表面から1mにて測定した値です。  
電源PWMは保証外とします。  
電源の電圧リップルは定格電圧の±5%以下とします。  
上記以外の定格電圧については、個別にお問い合わせ下さい。

(Note) The data shows typical value at rated voltage.  
Sound Level is measured at the distance of one(1) meter from the axis of fan intake.  
Insurance does not apply to power supply PWM.  
The range of voltage ripples for power supply is ±5%.  
Contact us on any rated voltage not listed above.

## 特性グラフ P-Q Curve

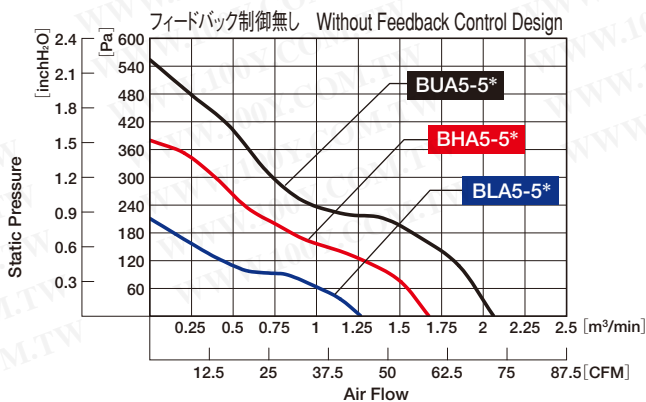
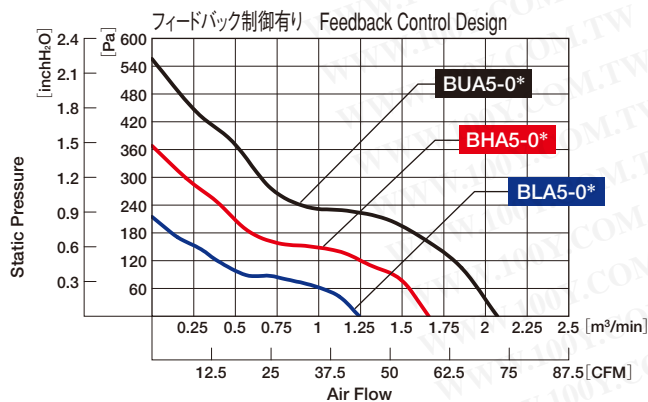

# 60×60×38mm Series



使用材料 /  
 ハウジング: プラスチック (UL:V-0)  
 インペラー: プラスチック (UL:V-0)  
 軸受構造 / ボールベアリング  
 保護方法 / 電流制限  
 使用温度範囲 / -10°C ~ 70°C  
 質量 / 140g

MATERIAL /  
 HOUSING: Plastic (UL:V-0)  
 IMPELLER: Plastic (UL:V-0)  
 BEARING / Ball Bearings  
 PROTECTION / Current limit  
 OPERATING TEMP / -10°C ~ 70°C  
 MASS / 140g

## ■外形図 External Dimensions

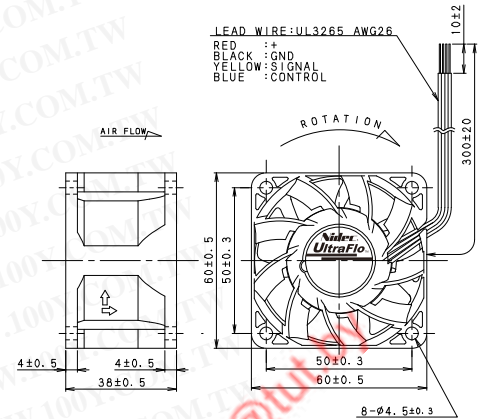

## ■取り付け穴参考寸法 Panel Out - Cuts

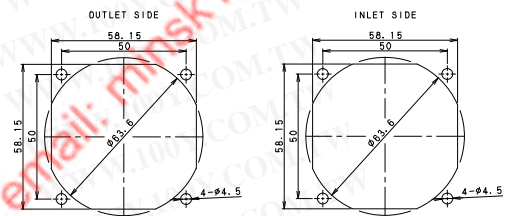

## ■特性 Major Characteristic Parameters

### ●フィードバック制御有り Feedback Control Design

Model	Rated Voltage	Operating Voltage range	Rated Current	Maximum Air Flow		Maximum Static Pressure		Rated Input Power	Sound Level	Rated Speed
	V	V	A	m <sup>3</sup> /min	CFM	Pa	inchH <sub>2</sub> O	W	dB (A)	min <sup>-1</sup>
V60E12BLA7-0*	12	7.0~13.8	0.50	1.10	38.8	165	0.66	6.00	51.5	7000
V60E12BMA7-0*	12	7.0~13.8	0.65	1.25	44.1	210	0.84	7.80	54.0	8000
V60E12BHA7-0*	12	7.0~13.8	1.05	1.50	53.0	290	1.17	12.60	58.5	9500
V60E12BGA7-0*	12	7.0~13.8	1.65	1.75	61.8	410	1.65	19.80	62.5	11000
V60E12BUA7-0*	12	7.0~13.8	2.10	1.95	68.9	480	1.93	25.20	64.5	12000

### ●フィードバック制御無し Without Feedback Control Design

Model	Rated Voltage	Operating Voltage range	Rated Current	Maximum Air Flow		Maximum Static Pressure		Rated Input Power	Sound Level	Rated Speed
	V	V	A	m <sup>3</sup> /min	CFM	Pa	inchH <sub>2</sub> O	W	dB (A)	min <sup>-1</sup>
V60E12BLA7-5*	12	7.0~13.8	0.50	1.10	38.8	165	0.66	6.00	51.5	7000
V60E12BMA7-5*	12	7.0~13.8	0.65	1.25	44.1	220	0.88	7.80	54.0	8000
V60E12BHA7-5*	12	7.0~13.8	1.05	1.50	53.0	290	1.17	12.60	58.5	9500
V60E12BGA7-5*	12	7.0~13.8	1.65	1.75	61.8	410	1.65	19.80	62.5	11000
V60E12BUA7-5*	12	7.0~13.8	2.10	1.95	68.9	495	1.99	25.20	64.5	12000

(注) データは定格電圧での代表特性です。  
 Sound Levelは吸込側表面から1mにて測定した値です。  
 電源PWMは保証外とします。  
 電源の電圧リップルは定格電圧の±5%以下とします。  
 上記以外の定格電圧については、個別にお問い合わせ下さい。

(Note) The data shows typical value at rated voltage.  
 Sound Level is measured at the distance of one(1) meter from the axis of fan intake.  
 Insurance does not apply to power supply PWM.  
 The range of voltage ripples for power supply is ±5%.  
 Contact us on any rated voltage not listed above.

## ■特性グラフ P-Q Curve

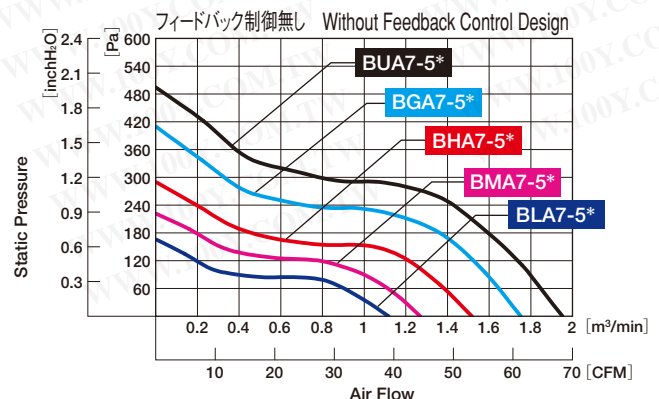
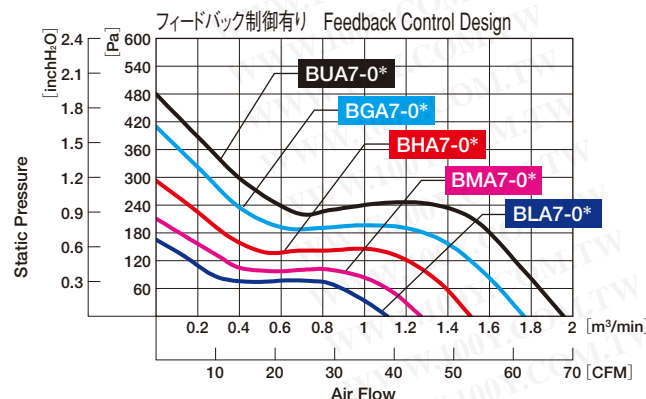

# 60×60×38mm Series



使用材料/  
ハウジング: プラスチック (UL:V-0)  
インペラー: プラスチック (UL:V-0)  
軸受構造/ボールベアリング  
保護方法/電流制限  
使用温度範囲/−10°C~70°C  
質量/140g

MATERIAL/  
HOUSING: Plastic (UL:V-0)  
IMPELLER: Plastic (UL:V-0)  
BEARING/ Ball Bearings  
PROTECTION/ Current limit  
OPERATING TEMP/ −10°C~70°C  
MASS/ 140g

## 外形図 External Dimensions

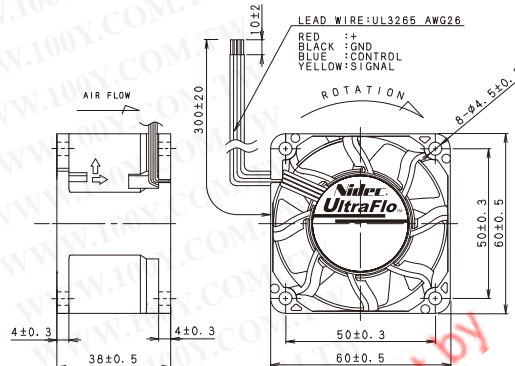

## 取り付け穴参考寸法 Panel Out - Cuts

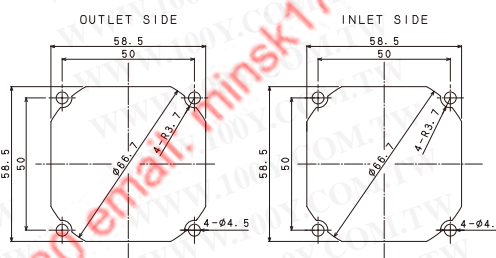

## 特性 Major Characteristic Parameters

### ●フィードバック制御有り Feedback Control Design

Model	Rated Voltage	Operating Voltage range	Rated Current	Maximum Air Flow		Maximum Static Pressure		Rated Input Power	Sound Level	Rated Speed
	V	V	A	m <sup>3</sup> /min	CFM	Pa	inchH <sub>2</sub> O	W	dB (A)	min <sup>-1</sup>
V60E12BHB5-0*	12	7.0~13.8	1.09	1.53	54.0	345	1.39	13.08	56.5	10500
V60E12BGB5-0*	12	7.0~13.8	1.43	1.78	62.9	505	2.03	17.16	59.0	12000

### ●フィードバック制御無し Without Feedback Control Design

Model	Rated Voltage	Operating Voltage range	Rated Current	Maximum Air Flow		Maximum Static Pressure		Rated Input Power	Sound Level	Rated Speed
	V	V	A	m <sup>3</sup> /min	CFM	Pa	inchH <sub>2</sub> O	W	dB (A)	min <sup>-1</sup>
V60E12BHB5-5*	12	7.0~13.8	1.09	1.53	54.0	329	1.32	13.08	56.5	10500
V60E12BGB5-5*	12	7.0~13.8	1.43	1.78	62.9	450	1.81	17.16	59.0	12000

(注) データは定格電圧での代表特性です。  
Sound Levelは吸込側表面から1mにて測定した値です。  
電源PWMは保証外とします。  
電源の電圧リップルは定格電圧の±5%以下とします。  
上記以外の定格電圧については、個別にお問い合わせ下さい。

(Note) The data shows typical value at rated voltage.  
Sound Level is measured at the distance of one(1) meter from the axis of fan intake.  
Insurance does not apply to power supply PWM.  
The range of voltage ripples for power supply is ±5%.  
Contact us on any rated voltage not listed above.

## 特性グラフ P-Q Curve

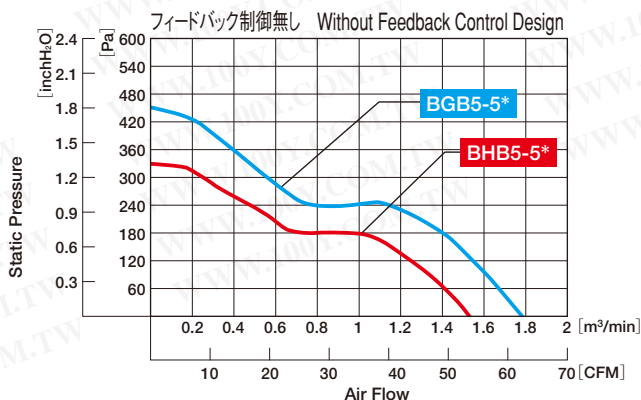
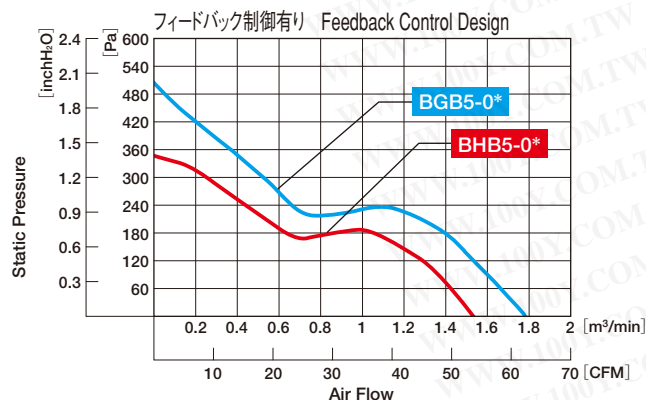



# 70×70×15mm Series



使用材料/  
ハウジング: プラスチック (UL:V-0)  
インペラー: プラスチック (UL:V-0)  
軸受構造/ **NBRX**タイプ  
保護方法/ 電流制限  
使用温度範囲/ -10°C~70°C  
質量/ 49g

**MATERIAL**/  
HOUSING: Plastic (UL:V-0)  
IMPELLER: Plastic (UL:V-0)  
**BEARING**/ **NBRX** Type  
**PROTECTION**/ Current limit  
**OPERATING TEMP**/ -10°C~70°C  
**MASS**/ 49g

## 外形図 External Dimensions

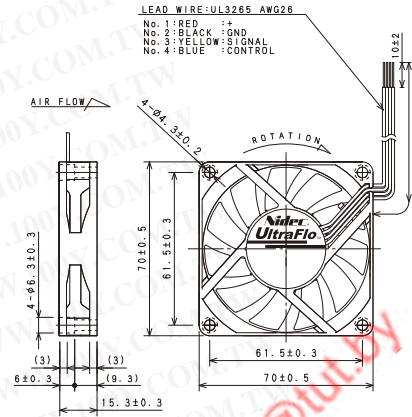

## 取り付け穴参考寸法 Panel Out - Cuts

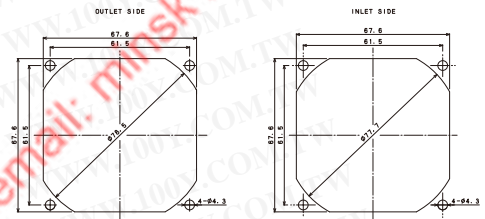

## 特性 Major Characteristic Parameters

●フィードバック制御無し Without Feedback Control Design

Model	Rated Voltage	Operating Voltage range	Rated Current	Maximum Air Flow		Maximum Static Pressure		Rated Input Power	Sound Level	Rated Speed
	V	V	A	m <sup>3</sup> /min	CFM	Pa	inchH <sub>2</sub> O	W	dB (A)	min <sup>-1</sup>
U70R12MMCB-5*	12	7.0~13.8	0.12	0.64	22.6	25	0.10	1.44	29.0	3000
U70R12MHCB-5*	12	7.0~13.8	0.21	0.86	30.4	43	0.17	2.52	37.0	4000
U70R12MS1CB-5*	12	7.0~13.8	0.28	0.94	33.2	49	0.20	3.36	39.0	4300

(注) データは定格電圧での代表特性です。  
Sound Levelは吸込側表面から1mにて測定した値です。  
電源PWMは保証外とします。  
電源の電圧リップルは定格電圧の±5%以下とします。  
上記以外の定格電圧については、個別にお問い合わせ下さい。

(Note) The data shows typical value at rated voltage.  
Sound Level is measured at the distance of one(1)meter from the axis of fan intake.  
Insurance does not apply to power supply PWM.  
The range of voltage ripples for power supply is ±5%.  
Contact us on any rated voltage not listed above.

## 特性グラフ P-Q Curve

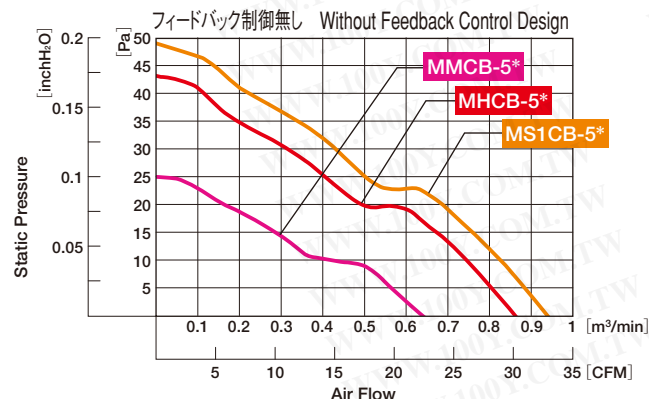

# 70×70×25mm Series



**使用材料 /**  
 ハウジング: プラスチック (UL:V-0)  
 インペラー: プラスチック (UL:V-0)  
**軸受構造 / NBRXタイプ**  
**保護方法 / 電流制限**  
 使用温度範囲 / -10°C~70°C  
 質量 / 85g

**MATERIAL /**  
 HOUSING: Plastic (UL:V-0)  
 IMPELLER: Plastic (UL:V-0)  
**BEARING / NBRX Type**  
**PROTECTION / Current limit**  
**OPERATING TEMP / -10°C~70°C**  
**MASS / 85g**

## 外形図 External Dimensions

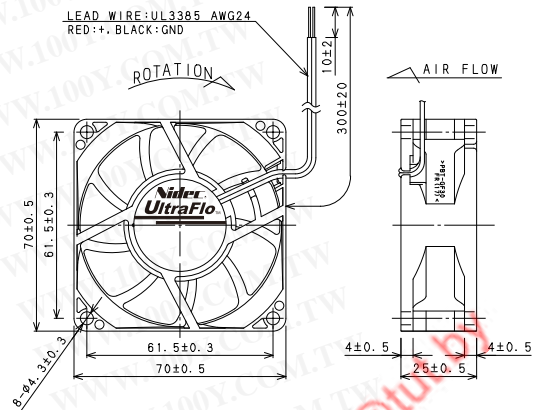

## 取り付け穴参考寸法 Panel Out - Cuts

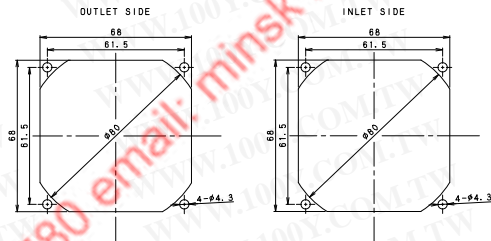

## 特性 Major Characteristic Parameters

●フィードバック制御無し Without Feedback Control Design

Model	Rated Voltage	Operating Voltage range	Rated Current	Maximum Air Flow		Maximum Static Pressure		Rated Input Power	Sound Level	Rated Speed
	V	V	A	m <sup>3</sup> /min	CFM	Pa	inchH <sub>2</sub> O	W	dB (A)	min <sup>-1</sup>
T70T12MLA9-5*	12	7.0~13.8	0.10	0.68	24.0	27	0.11	1.20	25.0	2600
T70T12MMA9-5*	12	7.0~13.8	0.14	0.82	28.9	38	0.15	1.68	29.5	3100
T70T12MHA9-5*	12	7.0~13.8	0.24	1.05	37.1	58	0.23	2.88	35.0	3900

(注) データは定格電圧での代表特性です。  
 Sound Levelは吸込側表面から1mにて測定した値です。  
 電源PWMは保証外とします。  
 電源の電圧リップルは定格電圧の±5%以下とします。  
 上記以外の定格電圧については、個別にお問い合わせ下さい。

(Note) The data shows typical value at rated voltage.  
 Sound Level is measured at the distance of one(1)meter from the axis of fan intake.  
 Insurance does not apply to power supply PWM.  
 The range of voltage ripples for power supply is ±5%.  
 Contact us on any rated voltage not listed above.

## 特性グラフ P-Q Curve

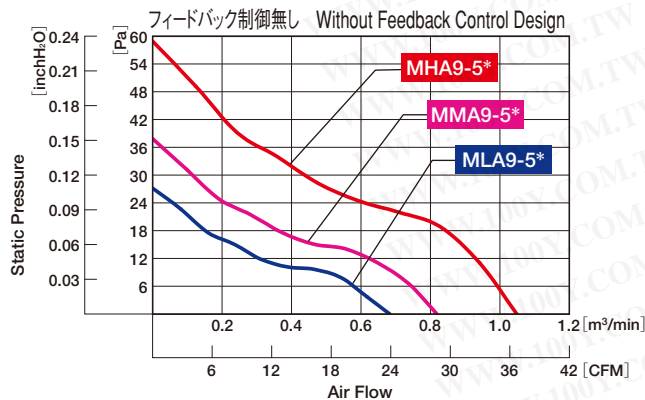

# 70x70x38mm Series



使用材料/  
ハウジング: プラスチック (UL:V-0)  
インペラー: プラスチック (UL:V-0)  
軸受構造/ボールベアリング  
保護方法/電流制限  
使用温度範囲/−10°C~70°C  
質量/150g

MATERIAL/  
HOUSING: Plastic (UL:V-0)  
IMPELLER: Plastic (UL:V-0)  
BEARING/ Ball Bearings  
PROTECTION/ Current limit  
OPERATING TEMP/ −10°C~70°C  
MASS/ 150g

## ■外形図 External Dimensions

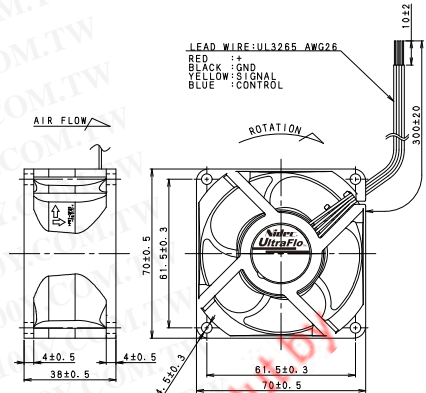

## ■取り付け穴参考寸法 Panel Out - Cuts

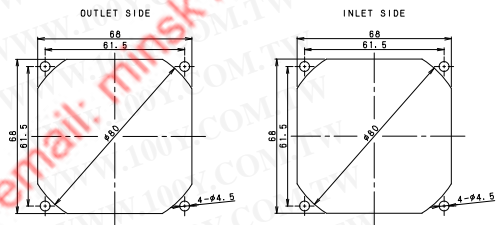

## ■特性 Major Characteristic Parameters

### ●フィードバック制御有り Feedback Control Design

Model	Rated Voltage	Operating Voltage range	Rated Current	Maximum Air Flow		Maximum Static Pressure		Rated Input Power	Sound Level	Rated Speed
	V	V	A	m <sup>3</sup> /min	CFM	Pa	inchH <sub>2</sub> O	W	dB (A)	min <sup>-1</sup>
T70E12BLA5-0*	12	7.0~13.8	0.20	0.95	33.5	100	0.40	2.40	40.0	4500
T70E12BMA5-0*	12	7.0~13.8	0.30	1.20	42.4	140	0.56	3.60	42.5	5500
T70E12BHA5-0*	12	7.0~13.8	0.40	1.40	49.4	190	0.76	4.80	45.5	6500
T70E12BGA5-0*	12	7.0~13.8	0.80	1.85	65.3	310	1.25	9.60	51.5	8500
T70E12BUA5-0*	12	7.0~13.8	1.10	2.20	77.7	405	1.63	13.20	56.0	10000

### ●フィードバック制御無し Without Feedback Control Design

Model	Rated Voltage	Operating Voltage range	Rated Current	Maximum Air Flow		Maximum Static Pressure		Rated Input Power	Sound Level	Rated Speed
	V	V	A	m <sup>3</sup> /min	CFM	Pa	inchH <sub>2</sub> O	W	dB (A)	min <sup>-1</sup>
T70E12BLA5-5*	12	7.0~13.8	0.20	0.95	33.5	85	0.34	2.40	40.0	4500
T70E12BMA5-5*	12	7.0~13.8	0.30	1.20	42.4	125	0.50	3.60	42.5	5500
T70E12BHA5-5*	12	7.0~13.8	0.40	1.40	49.4	170	0.68	4.80	45.5	6500
T70E12BGA5-5*	12	7.0~13.8	0.80	1.85	65.3	285	1.15	9.60	51.5	8500
T70E12BUA5-5*	12	7.0~13.8	1.10	2.20	77.7	370	1.49	13.20	56.0	10000

(注) データは定格電圧での代表特性です。  
Sound Levelは吸込側表面から1mにて測定した値です。  
電源PWMは保証外とします。  
電源の電圧リップルは定格電圧の±5%以下とします。  
上記以外の定格電圧については、個別にお問い合わせ下さい。

(Note) The data shows typical value at rated voltage.  
Sound Level is measured at the distance of one(1) meter from the axis of fan intake.  
Insurance does not apply to power supply PWM.  
The range of voltage ripples for power supply is ±5%.  
Contact us on any rated voltage not listed above.

## ■特性グラフ P-Q Curve

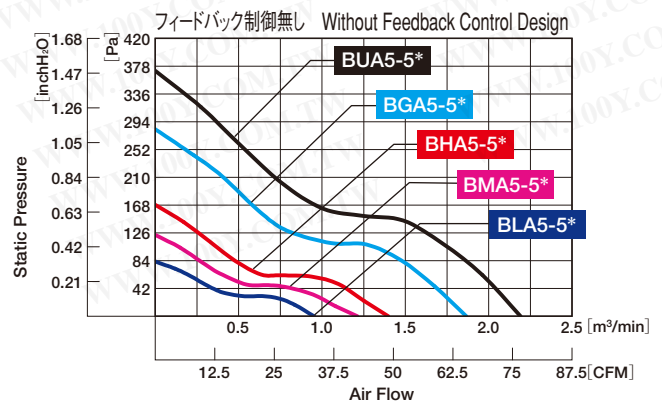
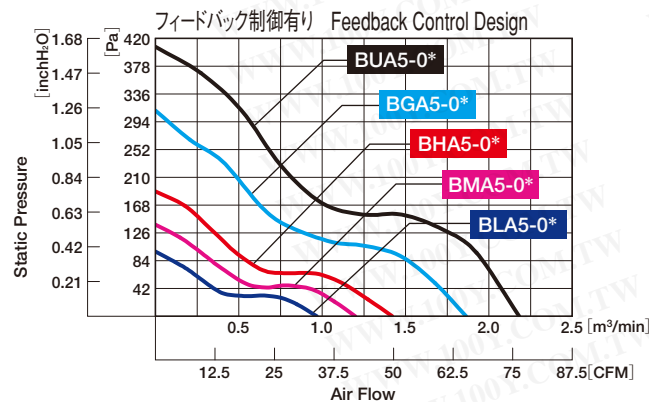

# 80×80×15mm Series



使用材料/ ハウジング: プラスチック (UL:V-0) インペラー: プラスチック (UL:V-0) 軸受構造/ <b>NBRX</b> タイプ 保護方法/電流制限 使用温度範囲/−10°C~70°C 質量/55g	<b>MATERIAL/</b> HOUSING: Plastic (UL:V-0) IMPELLER: Plastic (UL:V-0) <b>BEARING/</b> <i>NBRX</i> Type <b>PROTECTION/</b> Current limit <b>OPERATING TEMP/</b> −10°C~70°C <b>MASS/</b> 55g
--	--

## ■外形図 External Dimensions

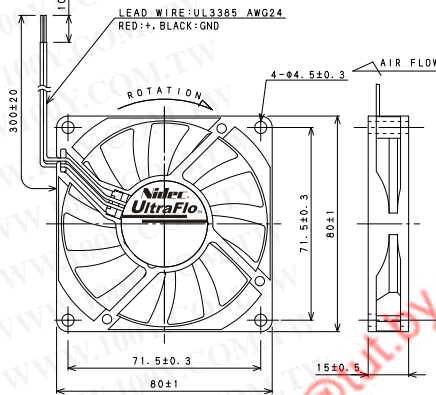

## ■取り付け穴参考寸法 Panel Out - Cuts

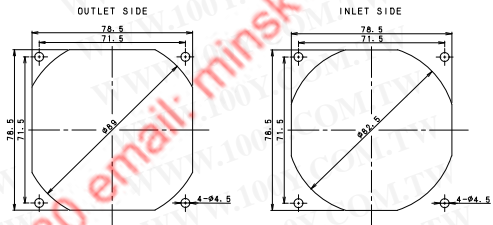

## ■特性 Major Characteristic Parameters

●フィードバック制御無し Without Feedback Control Design

Model	Rated Voltage	Operating Voltage range	Rated Current	Maximum Air Flow		Maximum Static Pressure		Rated Input Power	Sound Level	Rated Speed
	V	V	A	m <sup>3</sup> /min	CFM	Pa	inchH <sub>2</sub> O	W	dB (A)	min <sup>-1</sup>
U80R12MLAB-5*	12	7.0~13.8	0.12	0.62	21.89	15	0.06	1.44	24.0	2100
U80R12MMAB-5*	12	7.0~13.8	0.14	0.77	27.19	22	0.09	1.68	29.0	2550
U80R12MHAB-5*	12	7.0~13.8	0.22	0.97	34.25	32	0.13	2.64	34.0	3100

(注) データは定格電圧での代表特性です。  
Sound Levelは吸込側表面から1mにて測定した値です。  
電源PWMは保証外とします。  
電源の電圧リップルは定格電圧の±5%以下とします。  
上記以外の定格電圧については、個別にお問い合わせ下さい。

(Note) The data shows typical value at rated voltage.  
Sound Level is measured at the distance of one(1)meter from the axis of fan intake.  
Insurance does not apply to power supply PWM.  
The range of voltage ripples for power supply is ±5%.  
Contact us on any rated voltage not listed above.

## ■特性グラフ P-Q Curve

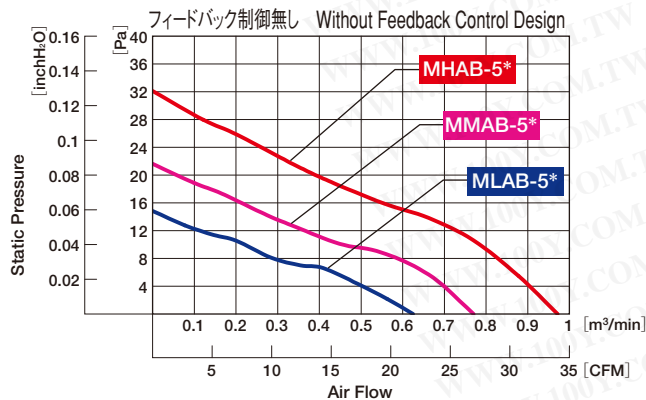

# 80x80x25mm Series



使用材料 /  
ハウジング: プラスチック (UL:V-0)  
インペラー: プラスチック (UL:V-0)  
軸受構造 / **NBRX** タイプ  
保護方法 / 電流制限  
使用温度範囲 / -10°C~70°C  
質量 / 92g

**MATERIAL** /  
HOUSING: Plastic (UL:V-0)  
IMPELLER: Plastic (UL:V-0)  
**BEARING** / **NBRX** Type  
**PROTECTION** / Current limit  
**OPERATING TEMP** / -10°C~70°C  
**MASS** / 92g

\* 通し穴タイプも対応可能です。

\* Closed flange type is also available.

## 外形図 External Dimensions

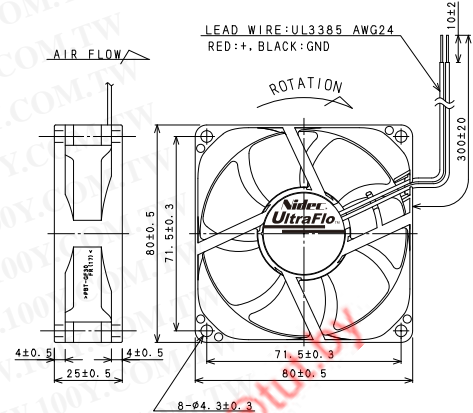

## 取り付け穴参考寸法 Panel Out - Cuts

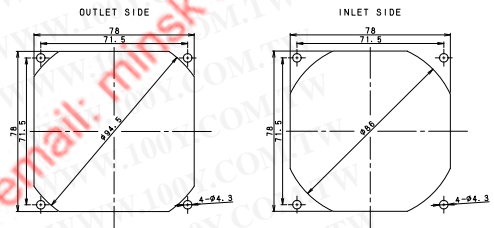

## 特性 Major Characteristic Parameters

●フィードバック制御無し Without Feedback Control Design

Model	Rated Voltage	Operating Voltage range	Rated Current	Maximum Air Flow		Maximum Static Pressure		Rated Input Power	Sound Level	Rated Speed
	V	V	A	m <sup>3</sup> /min	CFM	Pa	inchH <sub>2</sub> O	W	dB (A)	min <sup>-1</sup>
T80T12MMA7-5*	12	7.0~13.8	0.09	0.71	25.0	19	0.07	1.08	17.5	2000
T80T12MHA7-5*	12	7.0~13.8	0.10	0.82	28.9	24	0.10	1.20	22.0	2300
T80T12MGA7-5*	12	7.0~13.8	0.14	0.97	34.4	32	0.13	1.68	27.5	2700
T80T12MUA7-5*	12	7.0~13.8	0.19	1.13	39.8	42	0.17	2.28	30.5	3100

(注) データは定格電圧での代表特性です。  
Sound Levelは吸込側表面から1mにて測定した値です。  
電源PWMは保証外とします。  
電源の電圧リップルは定格電圧の±5%以下とします。  
上記以外の定格電圧については、個別にお問い合わせ下さい。

(Note) The data shows typical value at rated voltage.  
Sound Level is measured at the distance of one(1)meter from the axis of fan intake.  
Insurance does not apply to power supply PWM.  
The range of voltage ripples for power supply is ±5%.  
Contact us on any rated voltage not listed above.

## 特性グラフ P-Q Curve

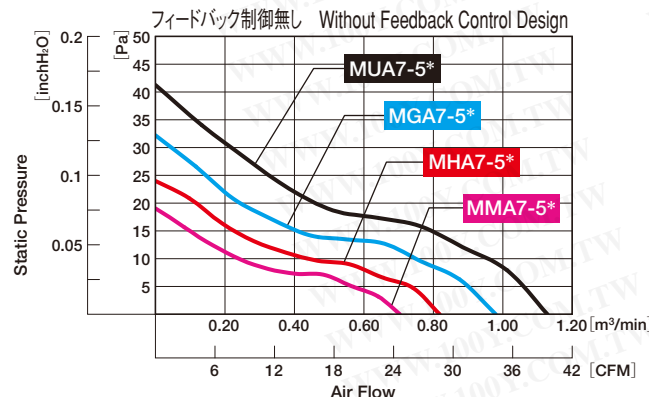

# 80×80×38mm Series



## ■外形図 External Dimensions

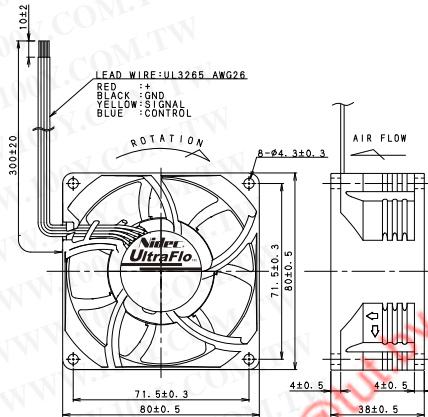

## ■取り付け穴参考寸法 Panel Out - Cuts

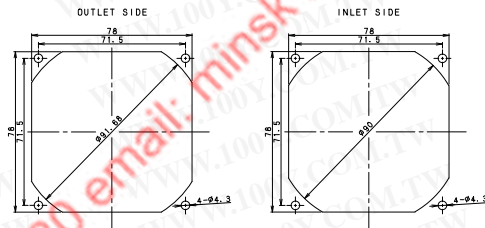

使用材料/ ハウジング: プラスチック (UL:V-0) インペラ: プラスチック (UL:V-0) 軸受構造/ボールベアリング 保護方法/電流制限 使用温度範囲/−10°C~70°C 質量/190g	<b>MATERIAL</b> / HOUSING: Plastic (UL:V-0) IMPELLER: Plastic (UL:V-0) <b>BEARING</b> /Ball Bearings <b>PROTECTION</b> /Current limit <b>OPERATING TEMP</b> /−10°C~70°C <b>MASS</b> /190g
--	---

## ■特性 Major Characteristic Parameters

### ●フィードバック制御有り Feedback Control Design

Model	Rated Voltage	Operating Voltage range	Rated Current	Maximum Air Flow		Maximum Static Pressure		Rated Input Power	Sound Level	Rated Speed
	V	V	A	m³/min	CFM	Pa	inchH <sub>2</sub> O	W	dB (A)	min <sup>-1</sup>
H80E12BLA7-0*	12	7.0~13.8	0.30	1.60	56.5	110	0.44	3.60	40.0	4200
H80E12BMA7-0*	12	7.0~13.8	0.40	1.80	63.6	140	0.56	4.80	44.0	4800
H80E12BHA7-0*	12	7.0~13.8	0.55	2.10	74.2	205	0.82	6.60	49.0	5500
H80E12BGA7-0*	12	7.0~13.8	0.90	2.40	84.7	235	0.94	10.80	54.0	6500
H80E12BUA7-0*	12	7.0~13.8	1.60	3.05	108	360	1.45	19.20	58.0	8000

### ●フィードバック制御無し Without Feedback Control Design

Model	Rated Voltage	Operating Voltage range	Rated Current	Maximum Air Flow		Maximum Static Pressure		Rated Input Power	Sound Level	Rated Speed
	V	V	A	m³/min	CFM	Pa	inchH <sub>2</sub> O	W	dB (A)	min <sup>-1</sup>
H80E12BLA7-5*	12	7.0~13.8	0.30	1.60	56.5	105	0.42	3.60	40.0	4200
H80E12BMA7-5*	12	7.0~13.8	0.40	1.80	63.6	130	0.52	4.80	44.0	4800
H80E12BHA7-5*	12	7.0~13.8	0.55	2.10	74.2	170	0.68	6.60	49.0	5500
H80E12BGA7-5*	12	7.0~13.8	0.90	2.40	84.7	235	0.95	10.80	54.0	6500
H80E12BUA7-5*	12	7.0~13.8	1.60	3.05	108	340	1.37	19.20	58.0	8000

(注) データは定格電圧での代表特性です。  
 Sound Levelは吸込側表面から1mにて測定した値です。  
 電源PWMは保証外とします。  
 電源の電圧リップルは定格電圧の±5%以下とします。  
 上記以外の定格電圧については、個別にお問い合わせ下さい。

(Note) The data shows typical value at rated voltage.  
 Sound Level is measured at the distance of one(1) meter from the axis of fan intake.  
 Insurance does not apply to power supply PWM.  
 The range of voltage ripples for power supply is ±5%.  
 Contact us on any rated voltage not listed above.

## ■特性グラフ P-Q Curve

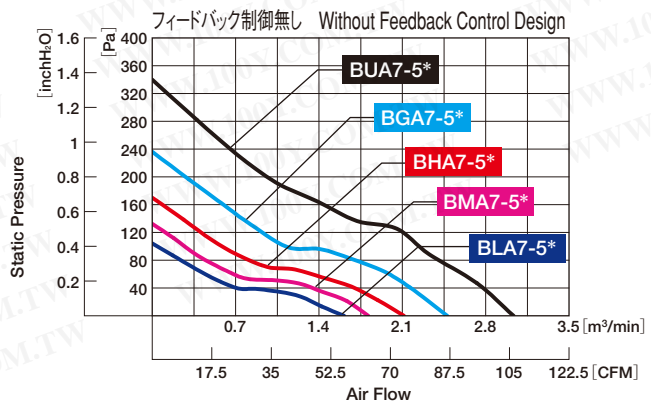
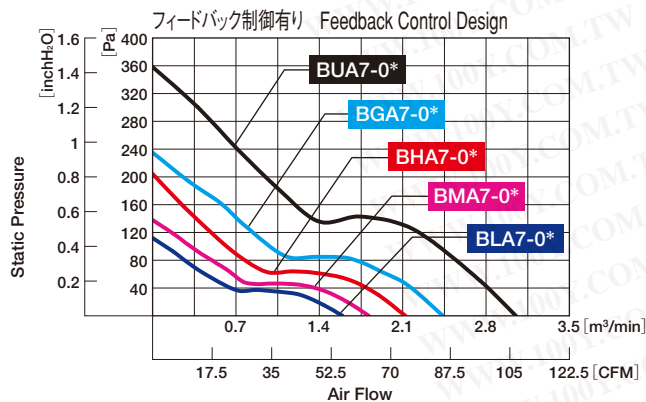

# 80×80×38mm Series



使用材料/  
ハウジング: プラスチック (UL:V-0)  
インペラー: プラスチック (UL:V-0)  
軸受構造/ボールベアリング  
保護方法/電流制限  
使用温度範囲/−10°C~70°C  
質量/180g

MATERIAL/  
HOUSING: Plastic (UL:V-0)  
IMPELLER: Plastic (UL:V-0)  
BEARING/ Ball Bearings  
PROTECTION/ Current limit  
OPERATING TEMP/ −10°C~70°C  
MASS/ 180g

## 外形図 External Dimensions

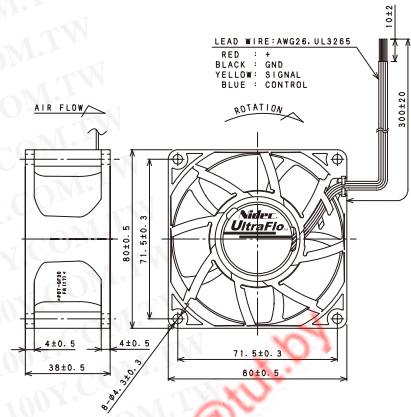

## 取り付け穴参考寸法 Panel Out - Cuts

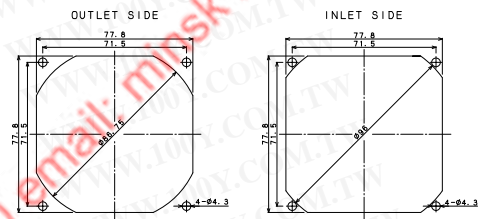

## 特性 Major Characteristic Parameters

### ●フィードバック制御有り Feedback Control Design

Model	Rated Voltage	Operating Voltage range	Rated Current	Maximum Air Flow		Maximum Static Pressure		Rated Input Power	Sound Level	Rated Speed
	V	V	A	m <sup>3</sup> /min	CFM	Pa	inchH <sub>2</sub> O	W	dB (A)	min <sup>-1</sup>
V80E12BHA5-0*	12	7.0~13.8	0.60	2.05	72.5	330	1.33	7.20	53.5	7000
V80E12BS1A5-0*	12	7.0~13.8	0.90	2.42	85.5	385	1.55	10.80	57.5	8200
V80E12BGA5-0*	12	7.0~13.8	1.40	2.83	100.0	490	1.97	16.80	61.0	9500

### ●フィードバック制御無し Without Feedback Control Design

Model	Rated Voltage	Operating Voltage range	Rated Current	Maximum Air Flow		Maximum Static Pressure		Rated Input Power	Sound Level	Rated Speed
	V	V	A	m <sup>3</sup> /min	CFM	Pa	inchH <sub>2</sub> O	W	dB (A)	min <sup>-1</sup>
V80E12BHA5-5*	12	7.0~13.8	0.60	2.05	72.5	270	1.09	7.20	53.5	7000
V80E12BS1A5-5*	12	7.0~13.8	0.90	2.42	85.5	340	1.37	10.80	57.5	8200
V80E12BGA5-5*	12	7.0~13.8	1.40	2.83	100.0	440	1.77	16.80	61.0	9500

(注) データは定格電圧での代表特性です。  
Sound Levelは吸込側表面から1mにて測定した値です。  
電源PWMは保証外とします。  
電源の電圧リップルは定格電圧の±5%以下とします。  
上記以外の定格電圧については、個別にお問い合わせ下さい。

(Note) The data shows typical value at rated voltage.  
Sound Level is measured at the distance of one(1) meter from the axis of fan intake.  
Insurance does not apply to power supply PWM.  
The range of voltage ripples for power supply is ±5%.  
Contact us on any rated voltage not listed above.

## 特性グラフ P-Q Curve

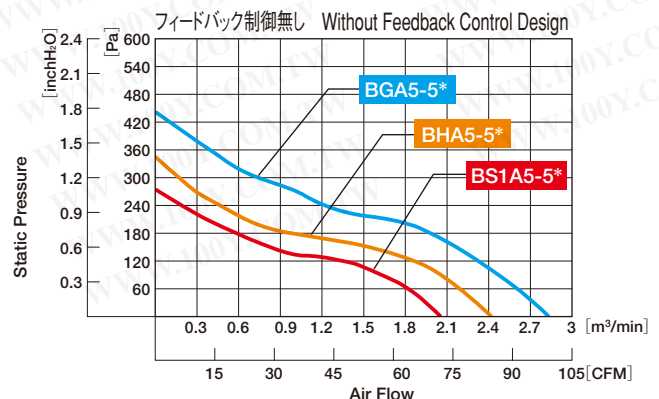
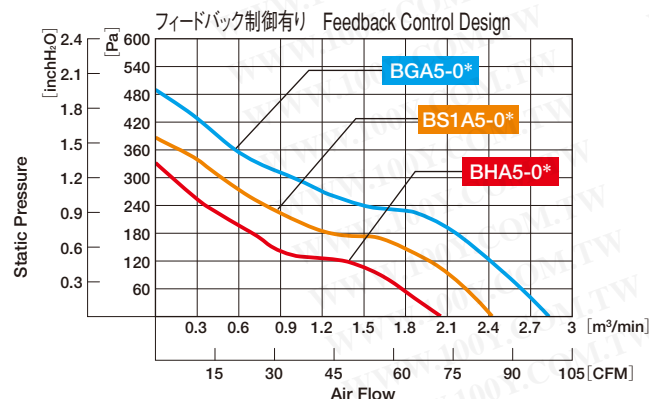

# 80×80×38mm Series



## ■外形図 External Dimensions

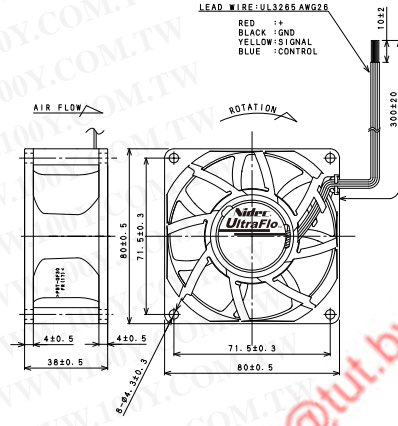

## ■取り付け穴参考寸法 Panel Out - Cuts

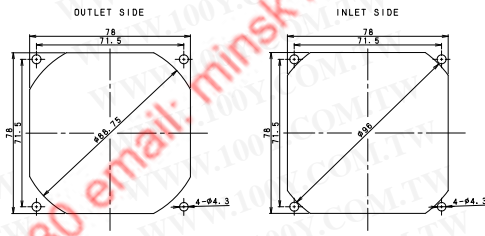

使用材料/  
 ハウジング: プラスチック (UL:V-0)  
 インペラ: プラスチック (UL:V-0)  
 軸受構造/ボールベアリング  
 保護方法/電流制限  
 使用温度範囲/−10°C~70°C  
 質量/175g

MATERIAL/  
 HOUSING: Plastic (UL:V-0)  
 IMPELLER: Plastic (UL:V-0)  
 BEARING/ Ball Bearings  
 PROTECTION/ Current limit  
 OPERATING TEMP/ −10°C~70°C  
 MASS/ 175g

## ■特性 Major Characteristic Parameters

### ●フィードバック制御有り Feedback Control Design

Model	Rated Voltage	Operating Voltage range	Rated Current	Maximum Air Flow		Maximum Static Pressure		Rated Input Power	Sound Level	Rated Speed
	V	V	A	m <sup>3</sup> /min	CFM	Pa	inchH <sub>2</sub> O	W	dB (A)	min <sup>-1</sup>
V80E12BLA7-0*	12	7.0~13.8	0.30	1.65	58.3	130	0.52	3.63	43.5	4500
V80E12BMA7-0*	12	7.0~13.8	0.48	2.02	71.4	180	0.72	5.76	48.5	5500
V80E12BHA7-0*	12	7.0~13.8	0.75	2.36	83.3	240	0.97	9.00	53.0	6500
V80E12BGA7-0*	12	7.0~13.8	1.70	3.09	109	390	1.57	20.40	60.0	8500
V80E12BUA7-0*	12	7.0~13.8	2.84	3.71	131	540	2.17	34.08	64.0	10000

### ●フィードバック制御無し Without Feedback Control Design

Model	Rated Voltage	Operating Voltage range	Rated Current	Maximum Air Flow		Maximum Static Pressure		Rated Input Power	Sound Level	Rated Speed
	V	V	A	m <sup>3</sup> /min	CFM	Pa	inchH <sub>2</sub> O	W	dB (A)	min <sup>-1</sup>
V80E12BLA7-5*	12	7.0~13.8	0.30	1.65	58.3	115	0.46	3.63	43.5	4500
V80E12BMA7-5*	12	7.0~13.8	0.48	2.02	71.3	160	0.64	5.76	48.5	5500
V80E12BHA7-5*	12	7.0~13.8	0.75	2.36	83.3	215	0.87	9.00	53.0	6500
V80E12BGA7-5*	12	7.0~13.8	1.70	3.09	109	360	1.45	20.40	60.0	8500
V80E12BUA7-5*	12	7.0~13.8	2.84	3.71	131	490	1.97	34.08	64.0	10000

(注) データは定格電圧での代表特性です。  
 Sound Levelは吸込側表面から1mにて測定した値です。  
 電源PWMは保証外とします。  
 電源の電圧リップルは定格電圧の±5%以下とします。  
 上記以外の定格電圧については、個別にお問い合わせ下さい。

(Note) The data shows typical value at rated voltage.  
 Sound Level is measured at the distance of one(1) meter from the axis of fan intake.  
 Insurance does not apply to power supply PWM.  
 The range of voltage ripples for power supply is ±5%.  
 Contact us on any rated voltage not listed above.

## ■特性グラフ P-Q Curve

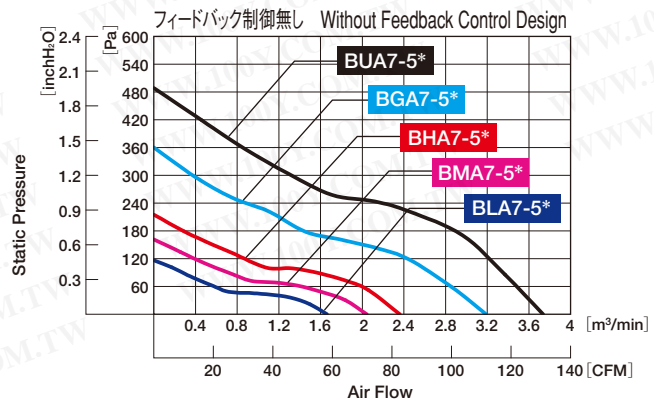
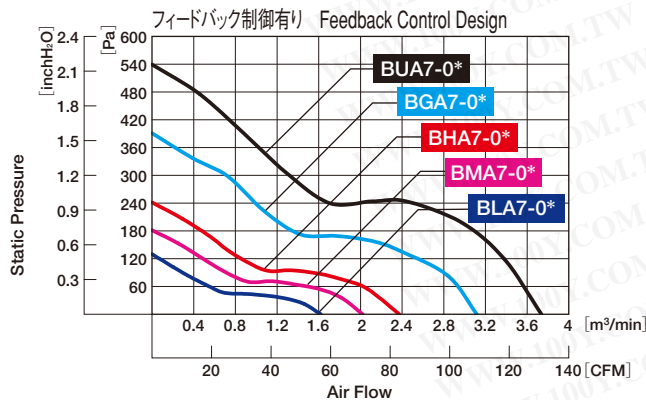



# 92×92×25mm Series



使用材料 /  
ハウジング: プラスチック (UL:V-0)  
インペラー: プラスチック (UL:V-0)  
軸受構造 / **NBRX**タイプ  
保護方法 / 電流制限  
使用温度範囲 / -10°C~70°C  
質量 / 112g

\* 通し穴タイプも対応可能です。

MATERIAL /  
HOUSING: Plastic (UL:V-0)  
IMPELLER: Plastic (UL:V-0)  
BEARING / **NBRX** Type  
PROTECTION / Current limit  
OPERATING TEMP / -10°C~70°C  
MASS / 112g

\* Closed flange type is also available.

## 外形図 External Dimensions

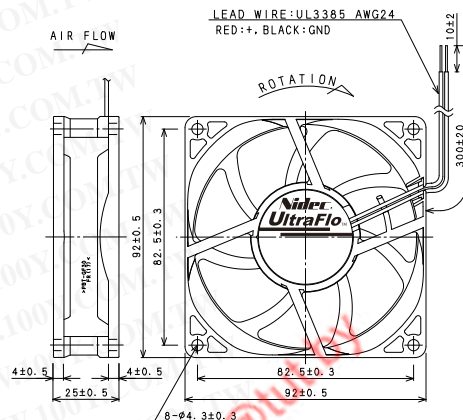

## 取り付け穴参考寸法 Panel Out - Cuts

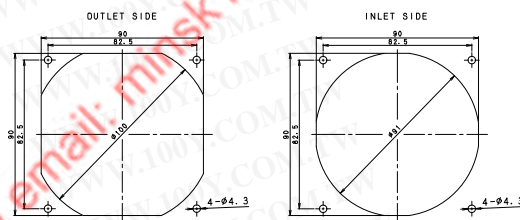

## 特性 Major Characteristic Parameters

●フィードバック制御無し Without Feedback Control Design

Model	Rated Voltage	Operating Voltage range	Rated Current	Maximum Air Flow		Maximum Static Pressure		Rated Input Power	Sound Level	Rated Speed
	V	V	A	m <sup>3</sup> /min	CFM	Pa	inchH <sub>2</sub> O	W	dB (A)	min <sup>-1</sup>
T92T12MMA7-5*	12	7.0~13.8	0.10	0.96	34.0	22	0.09	1.20	19.5	2050
T92T12MHA7-5*	12	7.0~13.8	0.14	1.13	40.1	30	0.12	1.68	25.0	2400
T92T12MGA7-5*	12	7.0~13.8	0.18	1.28	45.3	37	0.15	2.16	29.0	2700
T92T12MUA7-5*	12	7.0~13.8	0.25	1.48	52.1	46	0.18	3.00	32.0	3100

(注) データは定格電圧での代表特性です。  
Sound Levelは吸込側表面から1mにて測定した値です。  
電源PWMは保証外とします。  
電源の電圧リップルは定格電圧の±5%以下とします。  
上記以外の定格電圧については、個別にお問い合わせ下さい。

(Note) The data shows typical value at rated voltage.  
Sound Level is measured at the distance of one(1)meter from the axis of fan intake.  
Insurance does not apply to power supply PWM.  
The range of voltage ripples for power supply is ±5%.  
Contact us on any rated voltage not listed above.

## 特性グラフ P-Q Curve

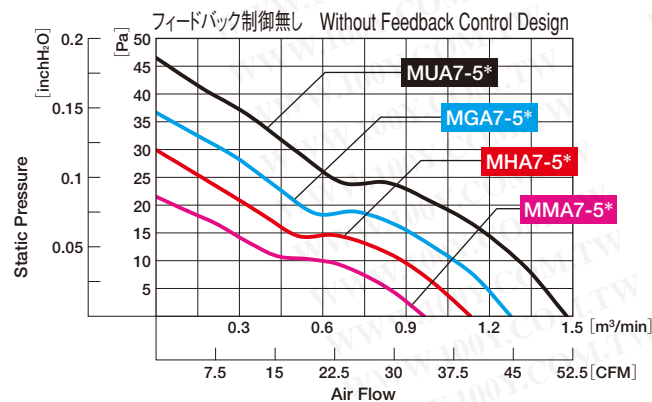

# 92×92×32mm Series



使用材料/  
ハウジング: プラスチック (UL:V-0)  
インペラー: プラスチック (UL:V-0)  
軸受構造/ボールベアリング  
保護方法/電流制限  
使用温度範囲/−10℃~70℃  
質量/180g

MATERIAL/  
HOUSING: Plastic (UL:V-0)  
IMPELLER: Plastic (UL:V-0)  
BEARING/ Ball Bearings  
PROTECTION/ Current limit  
OPERATING TEMP/ −10℃~70℃  
MASS/ 180g

## ■外形図 External Dimensions

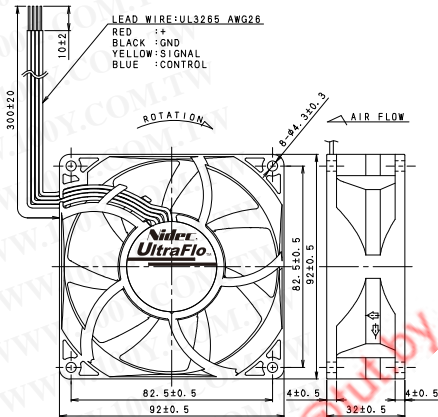

## ■取り付け穴参考寸法 Panel Out - Cuts

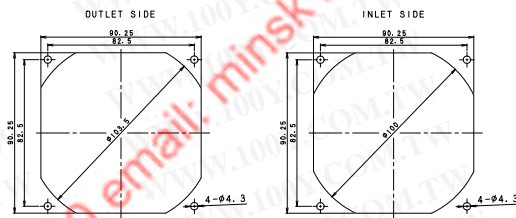

## ■特性 Major Characteristic Parameters

### ●フィードバック制御有り Feedback Control Design

Model	Rated Voltage	Operating Voltage range	Rated Current	Maximum Air Flow		Maximum Static Pressure		Rated Input Power	Sound Level	Rated Speed
	V	V	A	m <sup>3</sup> /min	CFM	Pa	inchH <sub>2</sub> O	W	dB (A)	min <sup>-1</sup>
H92C12BLA7-0*	12	7.0~13.8	0.19	1.58	55.8	55	0.22	2.28	36.0	2850
H92C12BMA7-0*	12	7.0~13.8	0.31	1.93	68.1	85	0.34	3.72	42.5	3500
H92C12BHA7-0*	12	7.0~13.8	0.48	2.40	84.7	125	0.50	5.76	48.0	4300
H92C12BGA7-0*	12	7.0~13.8	0.78	2.75	97.1	150	0.60	9.36	52.0	5000
H92C12BUA7-0*	12	7.0~13.8	1.41	3.37	119	210	0.84	16.92	58.0	6000

### ●フィードバック制御無し Without Feedback Control Design

Model	Rated Voltage	Operating Voltage range	Rated Current	Maximum Air Flow		Maximum Static Pressure		Rated Input Power	Sound Level	Rated Speed
	V	V	A	m <sup>3</sup> /min	CFM	Pa	inchH <sub>2</sub> O	W	dB (A)	min <sup>-1</sup>
H92C12BLA7-5*	12	7.0~13.8	0.19	1.58	55.8	50	0.20	2.28	36.0	2850
H92C12BMA7-5*	12	7.0~13.8	0.31	1.93	68.1	75	0.30	3.72	42.5	3500
H92C12BHA7-5*	12	7.0~13.8	0.48	2.40	84.7	105	0.42	5.76	48.0	4300
H92C12BGA7-5*	12	7.0~13.8	0.78	2.75	97.1	140	0.56	9.36	52.0	5000
H92C12BUA7-5*	12	7.0~13.8	1.41	3.37	119	180	0.72	16.92	58.0	6000

(注) データは定格電圧での代表特性です。  
Sound Levelは吸込側表面から1mにて測定した値です。  
電源PWMは保証外とします。  
電源の電圧リップルは定格電圧の±5%以下とします。  
上記以外の定格電圧については、個別にお問い合わせ下さい。

(Note) The data shows typical value at rated voltage.  
Sound Level is measured at the distance of one(1) meter from the axis of fan intake.  
Insurance does not apply to power supply PWM.  
The range of voltage ripples for power supply is ±5%.  
Contact us on any rated voltage not listed above.

## ■特性グラフ P-Q Curve

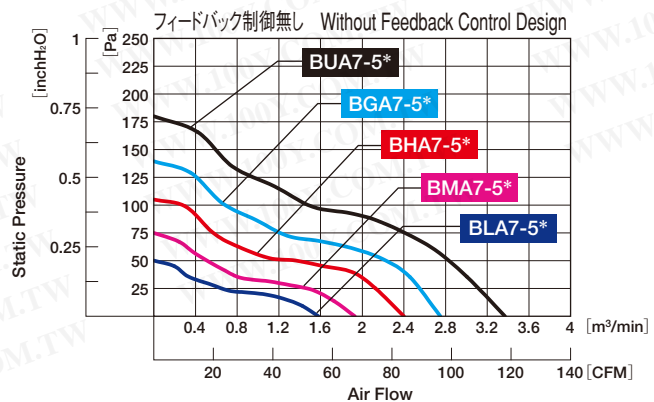
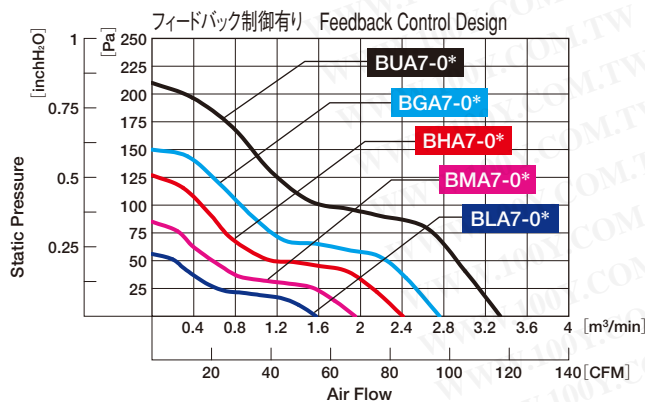

# 92×92×32mm Series



使用材料/  
ハウジング: プラスチック (UL:V-0)  
インペラー: プラスチック (UL:V-0)  
軸受構造 / **NBRX** タイプ  
保護方法 / 電流制限  
使用温度範囲 / -10°C~70°C  
質量 / 150g

MATERIAL /  
HOUSING: Plastic (UL:V-0)  
IMPELLER: Plastic (UL:V-0)  
BEARING / **NBRX** Type  
PROTECTION / Current limit  
OPERATING TEMP / -10°C~70°C  
MASS / 150g

## 外形図 External Dimensions

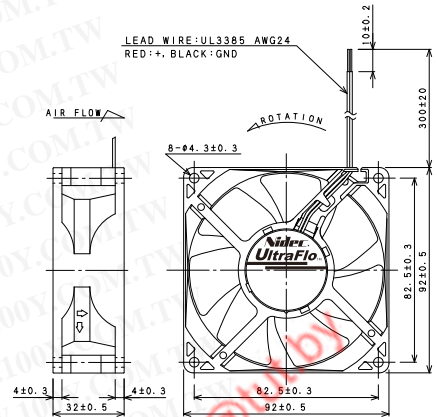

## 取り付け穴参考寸法 Panel Out - Cuts

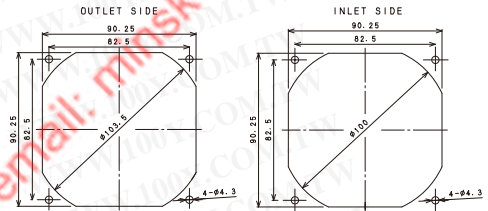

## 特性 Major Characteristic Parameters

●フィードバック制御無し Without Feedback Control Design

Model	Rated Voltage	Operating Voltage range	Rated Current	Maximum Air Flow		Maximum Static Pressure		Rated Input Power	Sound Level	Rated Speed
	V	V	A	m <sup>3</sup> /min	CFM	Pa	inchH <sub>2</sub> O	W	dB (A)	min <sup>-1</sup>
T92C12MMA7-5*	12	7.0~13.8	0.17	1.23	43.4	32.6	0.13	2.04	30.7	2300
T92C12MHA7-5*	12	7.0~13.8	0.20	1.38	48.7	38.6	0.16	2.40	33.8	2600
T92C12MGA7-5*	12	7.0~13.8	0.31	1.74	61.4	59.5	0.24	3.72	39.1	3200
T92C12MUA7-5*	12	7.0~13.8	0.55	2.02	71.3	81.7	0.33	6.60	43.5	3800

(注) データは定格電圧での代表特性です。  
Sound Levelは吸込側表面から1mにて測定した値です。  
電源PWMは保証外とします。  
電源の電圧リップルは定格電圧の±5%以下とします。  
上記以外の定格電圧については、個別にお問い合わせ下さい。

(Note) The data shows typical value at rated voltage.  
Sound Level is measured at the distance of one(1)meter from the axis of fan intake.  
Insurance does not apply to power supply PWM.  
The range of voltage ripples for power supply is ±5%.  
Contact us on any rated voltage not listed above.

## 特性グラフ P-Q Curve

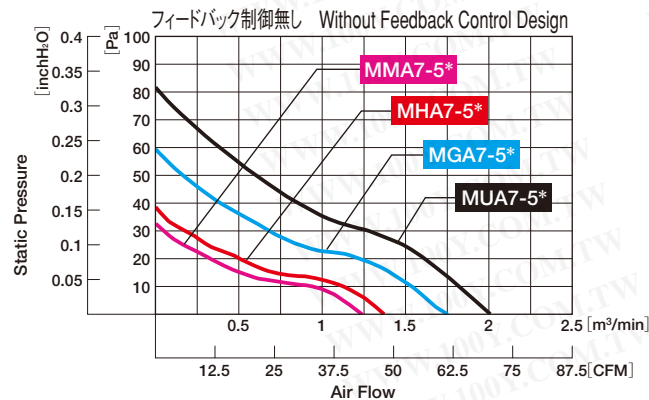

# 92×92×38mm Series



使用材料/ ハウジング: プラスチック (UL:V-0) インペラー: プラスチック (UL:V-0) 軸受構造/ボールベアリング 保護方法/電流制限 使用温度範囲/−10°C~70°C 質量/220g	MATERIAL/ HOUSING: Plastic (UL:V-0) IMPELLER: Plastic (UL:V-0) BEARING/ Ball Bearings PROTECTION/ Current limit OPERATING TEMP/ −10°C~70°C MASS/ 220g
---	---

## ■外形図 External Dimensions

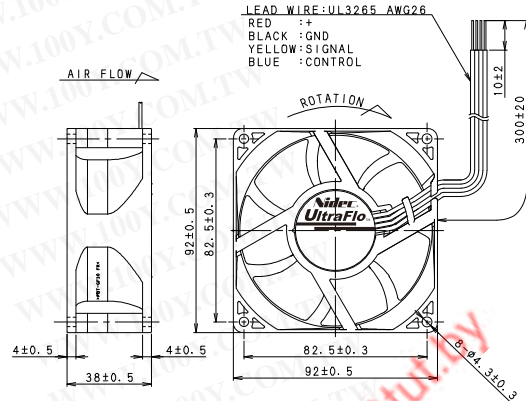

## ■取り付け穴参考寸法 Panel Out - Cuts

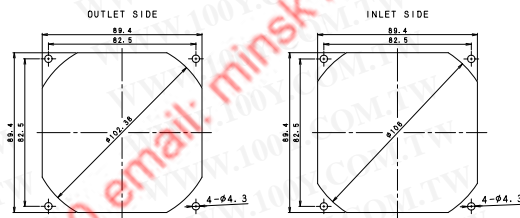

## ■特性 Major Characteristic Parameters

### ●フィードバック制御有り Feedback Control Design

Model	Rated Voltage	Operating Voltage range	Rated Current	Maximum Air Flow		Maximum Static Pressure		Rated Input Power	Sound Level	Rated Speed
	V	V	A	m <sup>3</sup> /min	CFM	Pa	inchH <sub>2</sub> O	W	dB (A)	min <sup>-1</sup>
T92E12BMA7-0*	12	7.0~13.8	0.39	2.35	83.0	125	0.50	4.68	43.5	4000
T92E12BHA7-0*	12	7.0~13.8	0.61	2.80	98.9	170	0.68	7.32	47.5	4800
T92E12BGA7-0*	12	7.0~13.8	1.34	3.70	131	270	1.09	16.08	57.0	6300
T92E12BUA7-0*	12	7.0~13.8	2.09	4.21	149	325	1.31	25.08	60.0	7200

### ●フィードバック制御無し Without Feedback Control Design

Model	Rated Voltage	Operating Voltage range	Rated Current	Maximum Air Flow		Maximum Static Pressure		Rated Input Power	Sound Level	Rated Speed
	V	V	A	m <sup>3</sup> /min	CFM	Pa	inchH <sub>2</sub> O	W	dB (A)	min <sup>-1</sup>
T92E12BMA7-5*	12	7.0~13.8	0.39	2.35	83.0	110	0.44	4.68	43.5	4000
T92E12BHA7-5*	12	7.0~13.8	0.61	2.80	98.9	145	0.58	7.32	47.5	4800
T92E12BGA7-5*	12	7.0~13.8	1.34	3.70	131	250	1.01	16.08	57.0	6300
T92E12BUA7-5*	12	7.0~13.8	2.09	4.21	149	300	1.21	25.08	60.0	7200

(注) データは定格電圧での代表特性です。  
Sound Levelは吸込側表面から1mにて測定した値です。  
電源PWMは保証外とします。  
電源の電圧リップルは定格電圧の±5%以下とします。  
上記以外の定格電圧については、個別にお問い合わせ下さい。

(Note) The data shows typical value at rated voltage.  
Sound Level is measured at the distance of one(1)meter from the axis of fan intake.  
Insurance does not apply to power supply PWM.  
The range of voltage ripples for power supply is ±5%.  
Contact us on any rated voltage not listed above.

## ■特性グラフ P-Q Curve

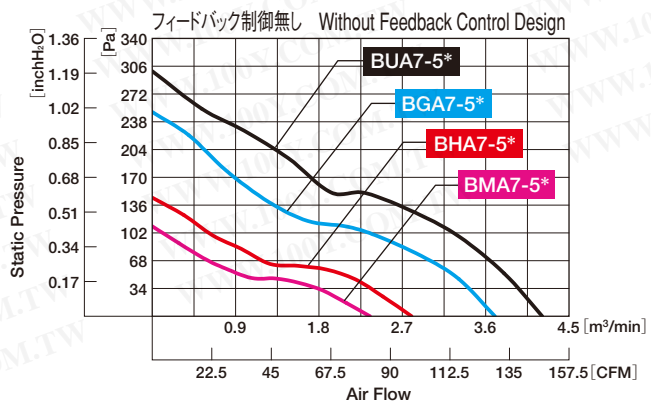
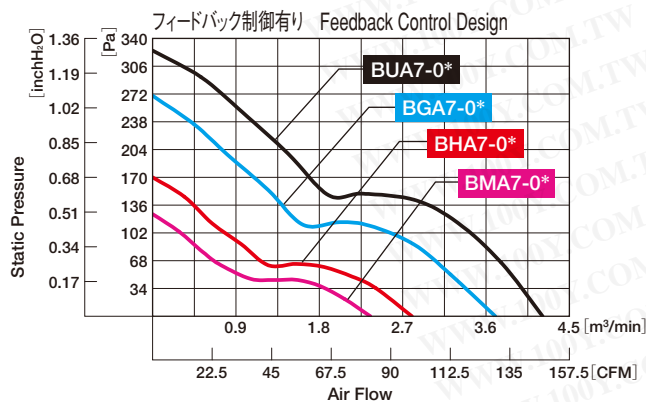

# 92×92×38mm Series



使用材料/  
ハウジング: プラスチック (UL:V-0)  
インペラー: プラスチック (UL:V-0)  
軸受構造/ボールベアリング  
保護方法/電流制限  
使用温度範囲/−10℃~70℃  
質量/216g

MATERIAL/  
HOUSING: Plastic (UL:V-0)  
IMPELLER: Plastic (UL:V-0)  
BEARING/ Ball Bearings  
PROTECTION/ Current limit  
OPERATING TEMP/ −10℃~70℃  
MASS/ 216g

## ■外形図 External Dimensions

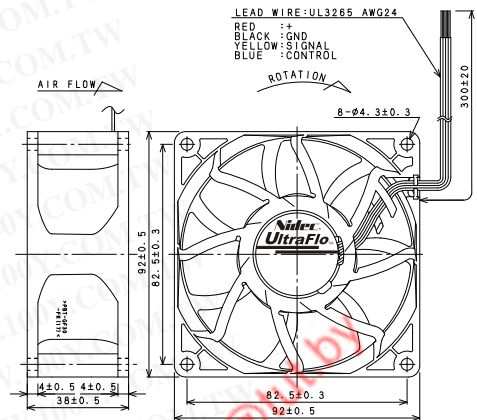

## ■取り付け穴参考寸法 Panel Out - Cuts

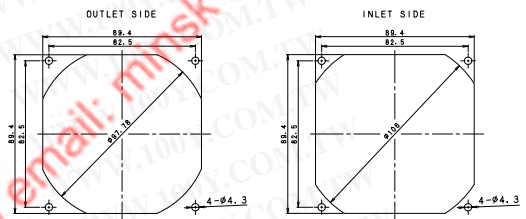

## ■特性 Major Characteristic Parameters

### ●フィードバック制御有り Feedback Control Design

Model	Rated Voltage	Operating Voltage range	Rated Current	Maximum Air Flow		Maximum Static Pressure		Rated Input Power	Sound Level	Rated Speed
	V	V	A	m <sup>3</sup> /min	CFM	Pa	inchH <sub>2</sub> O	W	dB (A)	min <sup>-1</sup>
V92E12BLA7-0*	12	7.0~13.8	0.36	2.32	81.7	140	0.56	4.36	44.0	4000
V92E12BMA7-0*	12	7.0~13.8	0.62	2.86	101	180	0.72	7.39	50.0	5000
V92E12BHA7-0*	12	7.0~13.8	1.32	3.80	134	285	1.15	15.84	56.5	6500
V92E12BGA7-0*	12	7.0~13.8	2.05	4.39	155	345	1.39	24.55	60.0	7500
V92E12BUA7-0*	12	7.0~13.8	2.97	5.05	178	460	1.85	35.64	64.0	8500

### ●フィードバック制御無し Without Feedback Control Design

Model	Rated Voltage	Operating Voltage range	Rated Current	Maximum Air Flow		Maximum Static Pressure		Rated Input Power	Sound Level	Rated Speed
	V	V	A	m <sup>3</sup> /min	CFM	Pa	inchH <sub>2</sub> O	W	dB (A)	min <sup>-1</sup>
V92E12BLA7-5*	12	7.0~13.8	0.36	2.32	81.7	115	0.46	4.36	44.0	4000
V92E12BMA7-5*	12	7.0~13.8	0.62	2.86	101	170	0.68	7.39	50.0	5000
V92E12BHA7-5*	12	7.0~13.8	1.32	3.80	134	255	1.03	15.84	56.5	6500
V92E12BGA7-5*	12	7.0~13.8	2.05	4.39	155	325	1.31	24.55	60.0	7500
V92E12BUA7-5*	12	7.0~13.8	2.97	5.05	178	400	1.61	35.64	64.0	8500

(注) データは定格電圧での代表特性です。  
Sound Levelは吸込側表面から1mにて測定した値です。  
電源PWMは保証外とします。  
電源の電圧リップルは定格電圧の±5%以下とします。  
上記以外の定格電圧については、個別にお問い合わせ下さい。

(Note) The data shows typical value at rated voltage.  
Sound Level is measured at the distance of one(1) meter from the axis of fan intake.  
Insurance does not apply to power supply PWM.  
The range of voltage ripples for power supply is ±5%.  
Contact us on any rated voltage not listed above.

## ■特性グラフ P-Q Curve

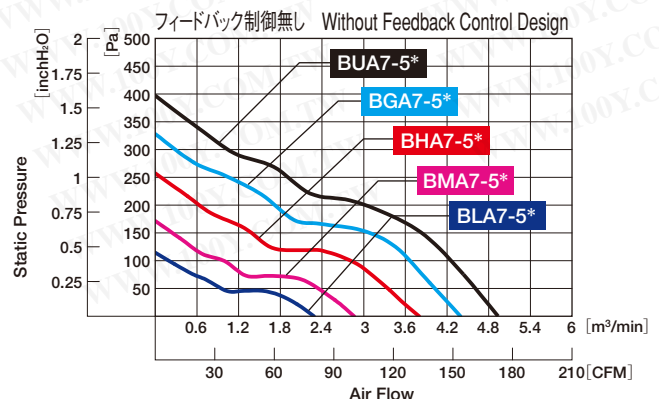
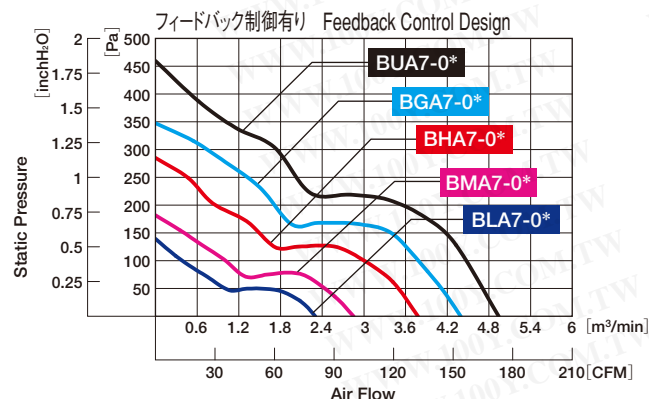

# 120×120×38mm Series



## ■外形図 External Dimensions

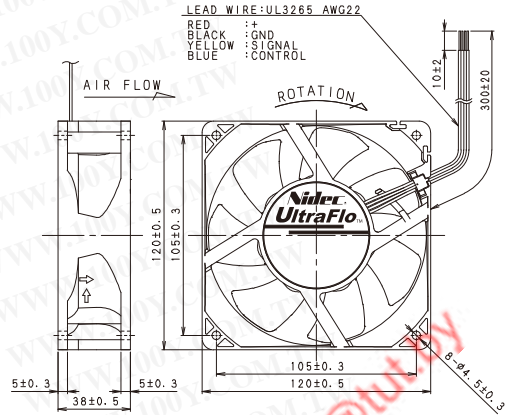

## ■取り付け穴参考寸法 Panel Out - Cuts

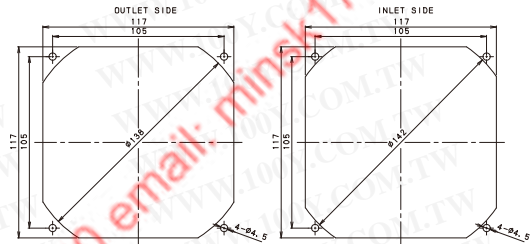

使用材料/  
 ハウジング: プラスチック (UL:V-0)  
 インペラー: プラスチック (UL:V-0)  
 軸受構造/ボールベアリング  
 保護方法/電流制限  
 使用温度範囲/−10°C~70°C  
 質量/370g

MATERIAL/  
 HOUSING: Plastic (UL:V-0)  
 IMPELLER: Plastic (UL:V-0)  
 BEARING/ Ball Bearings  
 PROTECTION/ Current limit  
 OPERATING TEMP/ −10°C~70°C  
 MASS/ 370g

## ■特性 Major Characteristic Parameters

### ●フィードバック制御有り Feedback Control Design

Model	Rated Voltage	Operating Voltage range	Rated Current	Maximum Air Flow		Maximum Static Pressure		Rated Input Power	Sound Level	Rated Speed
	V	V	A	m <sup>3</sup> /min	CFM	Pa	inchH <sub>2</sub> O	W	dB (A)	min <sup>-1</sup>
T12E48BHM7-0*	48	30.0~60.0	0.59	5.97	211	250	1.00	28.32	60.3	4800
T12E48BGM7-0*	48	30.0~60.0	0.82	6.64	234	305	1.22	39.36	63.0	5400

### ●フィードバック制御無し Without Feedback Control Design

Model	Rated Voltage	Operating Voltage range	Rated Current	Maximum Air Flow		Maximum Static Pressure		Rated Input Power	Sound Level	Rated Speed
	V	V	A	m <sup>3</sup> /min	CFM	Pa	inchH <sub>2</sub> O	W	dB (A)	min <sup>-1</sup>
T12E48BHM7-5*	48	30.0~60.0	0.59	5.97	211	224	0.90	28.32	60.3	4800
T12E48BGM7-5*	48	30.0~60.0	0.82	6.64	234	280	1.12	39.36	63.0	5400

(注) データは定格電圧での代表特性です。  
 Sound Levelは吸込側表面から1mにて測定した値です。  
 電源PWMは保証外とします。  
 電源の電圧リップルは定格電圧の±5%以下とします。  
 上記以外の定格電圧については、個別にお問い合わせ下さい。

(Note) The data shows typical value at rated voltage.  
 Sound Level is measured at the distance of one(1) meter from the axis of fan intake.  
 Insurance does not apply to power supply PWM.  
 The range of voltage ripples for power supply is ±5%.  
 Contact us on any rated voltage not listed above.

## ■特性グラフ P-Q Curve

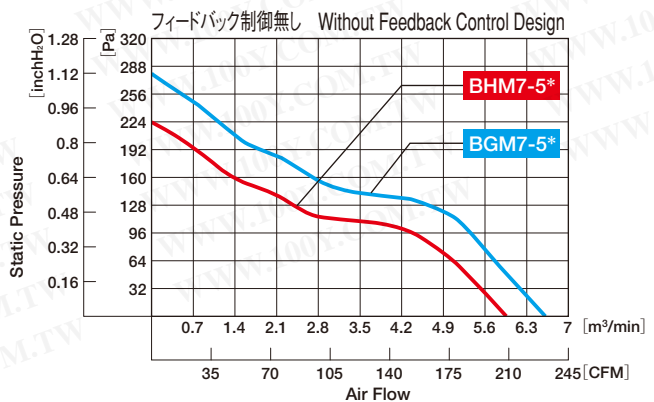
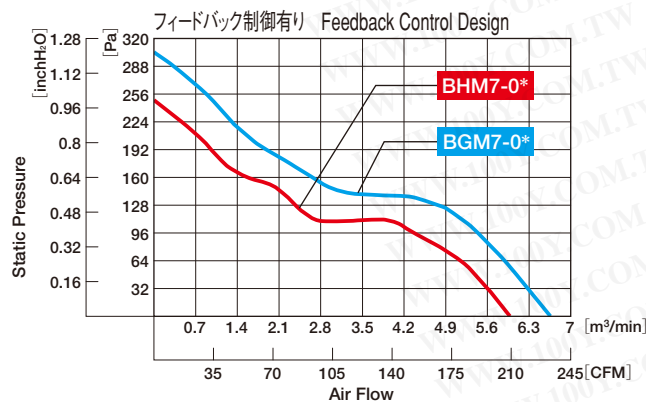

# 120×120×38mm Series



使用材料/  
ハウジング: プラスチック (UL:V-0)  
インペラー: プラスチック (UL:V-0)  
軸受構造/ボールベアリング  
保護方法/電流制限  
使用温度範囲/−10°C~70°C  
質量/265g

**MATERIAL/**  
HOUSING: Plastic (UL:V-0)  
IMPELLER: Plastic (UL:V-0)  
**BEARING/**Ball Bearings  
**PROTECTION/**Current limit  
**OPERATING TEMP/**−10°C~70°C  
**MASS/**265g

## 外形図 External Dimensions

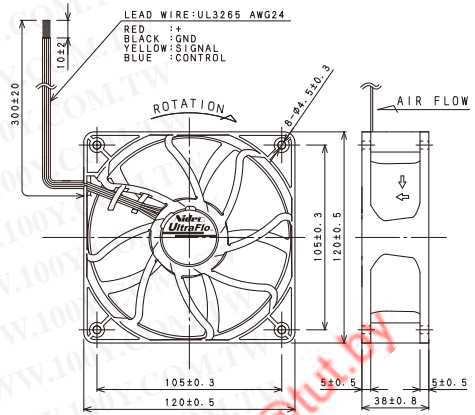

## 取り付け穴参考寸法 Panel Out - Cuts

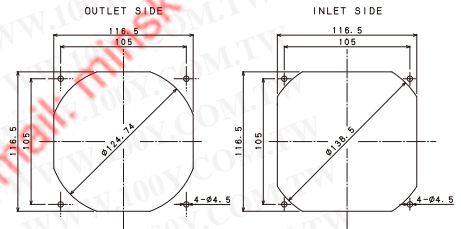

## 特性 Major Characteristic Parameters

### ●フィードバック制御有り Feedback Control Design

Model	Rated Voltage	Operating Voltage range	Rated Current	Maximum Air Flow		Maximum Static Pressure		Rated Input Power	Sound Level	Rated Speed
	V	V	A	m <sup>3</sup> /min	CFM	Pa	inchH <sub>2</sub> O	W	dB (A)	min <sup>-1</sup>
V12E12BHB5-0*	12	10.2~13.8	1.12	5.20	184	270	1.09	13.44	60.0	5700
V12E12BGB5-0*	12	10.2~13.8	2.29	6.37	225	340	1.37	27.48	66.5	7000

### ●フィードバック制御無し Without Feedback Control Design

Model	Rated Voltage	Operating Voltage range	Rated Current	Maximum Air Flow		Maximum Static Pressure		Rated Input Power	Sound Level	Rated Speed
	V	V	A	m <sup>3</sup> /min	CFM	Pa	inchH <sub>2</sub> O	W	dB (A)	min <sup>-1</sup>
V12E12BHB5-5*	12	10.2~13.8	1.12	5.20	184	230	0.93	13.44	60.0	5700
V12E12BGB5-5*	12	10.2~13.8	2.29	6.37	225	300	1.21	27.48	66.5	7000

(注) データは定格電圧での代表特性です。  
Sound Levelは吸込側表面から1mにて測定した値です。  
電源PWMは保証外とします。  
電源の電圧リップルは定格電圧の±5%以下とします。  
上記以外の定格電圧については、個別にお問い合わせ下さい。

(Note) The data shows typical value at rated voltage.  
Sound Level is measured at the distance of one(1)meter from the axis of fan intake.  
Insurance does not apply to power supply PWM.  
The range of voltage ripples for power supply is ±5%.  
Contact us on any rated voltage not listed above.

## 特性グラフ P-Q Curve

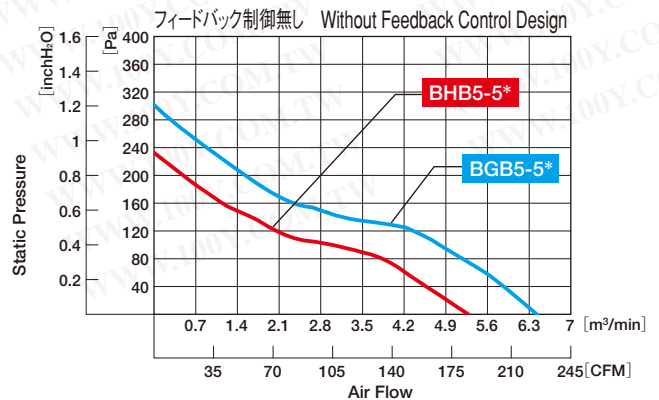
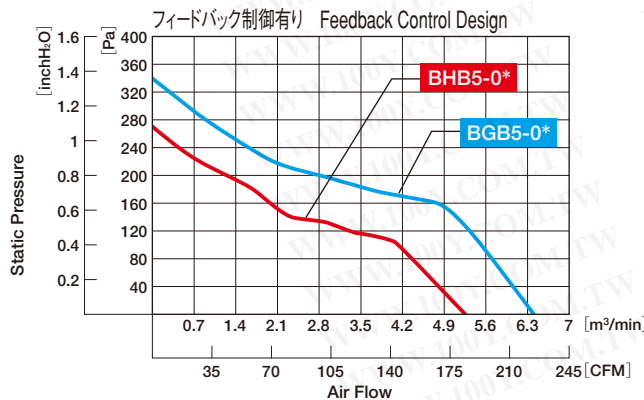

# 120×120×38mm Series



## ■外形図 External Dimensions

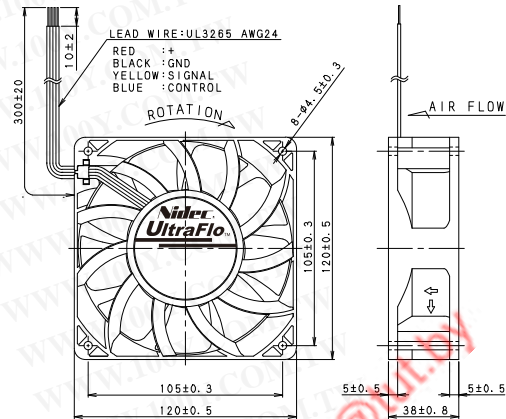

## ■取り付け穴参考寸法 Panel Out - Cuts

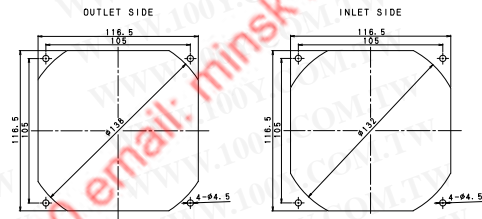

使用材料/ ハウジング: プラスチック (UL:V-0) インペラー: プラスチック (UL:V-0) 軸受構造/ボールベアリング 保護方法/電流制限 使用温度範囲/−10℃~70℃ 質量/380g	MATERIAL/ HOUSING: Plastic (UL:V-0) IMPELLER: Plastic (UL:V-0) BEARING/ Ball Bearings PROTECTION/ Current limit OPERATING TEMP/ −10℃~70℃ MASS/ 380g
---	---

## ■特性 Major Characteristic Parameters

### ●フィードバック制御有り Feedback Control Design

Model	Rated Voltage	Operating Voltage range	Rated Current	Maximum Air Flow		Maximum Static Pressure		Rated Input Power	Sound Level	Rated Speed
	V	V	A	m³/min	CFM	Pa	inchH <sub>2</sub> O	W	dB (A)	min <sup>-1</sup>
V12E12BLM9-0*	12	10.2~13.8	0.80	3.85	136	140	0.56	9.60	50.0	3200
V12E12BMM9-0*	12	10.2~13.8	1.20	4.40	155	190	0.76	14.40	54.5	3700
V12E12BHM9-0*	12	10.2~13.8	1.60	5.00	177	240	0.97	19.20	58.0	4200
V12E12BGM9-0*	12	10.2~13.8	2.10	5.60	198	275	1.11	25.20	63.0	4600
V12E12BUM9-0*	12	10.2~13.8	3.30	6.35	224	335	1.35	39.60	66.0	5300

### ●フィードバック制御無し Without Feedback Control Design

Model	Rated Voltage	Operating Voltage range	Rated Current	Maximum Air Flow		Maximum Static Pressure		Rated Input Power	Sound Level	Rated Speed
	V	V	A	m³/min	CFM	Pa	inchH <sub>2</sub> O	W	dB (A)	min <sup>-1</sup>
V12E12BLM9-5*	12	10.2~13.8	0.80	3.85	136	130	0.52	9.60	50.0	3200
V12E12BMM9-5*	12	10.2~13.8	1.20	4.40	155	180	0.72	14.40	54.5	3700
V12E12BHM9-5*	12	10.2~13.8	1.60	5.00	177	230	0.93	19.20	58.0	4200
V12E12BGM9-5*	12	10.2~13.8	2.10	5.60	198	265	1.07	25.20	63.0	4600
V12E12BUM9-5*	12	10.2~13.8	3.30	6.35	224	335	1.35	39.60	66.0	5300

(注) データは定格電圧での代表特性です。  
 Sound Levelは吸込側表面から1mにて測定した値です。  
 電源PWMは保証外とします。  
 電源の電圧リップルは定格電圧の±5%以下とします。  
 上記以外の定格電圧については、個別にお問い合わせ下さい。

(Note) The data shows typical value at rated voltage.  
 Sound Level is measured at the distance of one(1) meter from the axis of fan intake.  
 Insurance does not apply to power supply PWM.  
 The range of voltage ripples for power supply is ±5%.  
 Contact us on any rated voltage not listed above.

## ■特性グラフ P-Q Curve

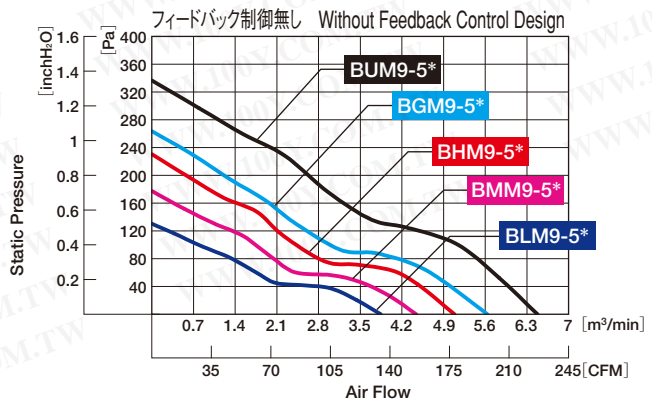
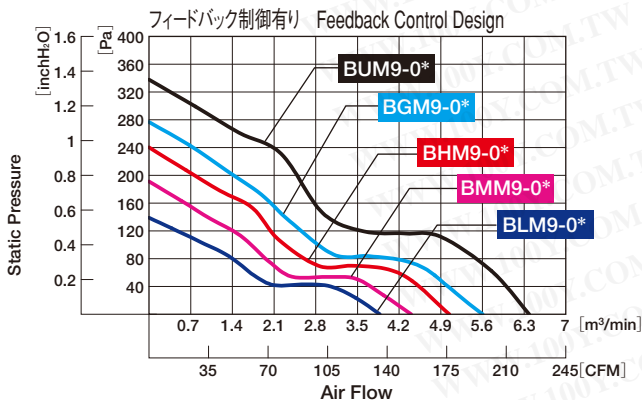



# φ 172×150×51 mm Series



**使用材料 /**  
 ハウジング: アルミダイカスト  
 インペラ: プラスチック (UL:V-0)  
**軸受構造 /** ボールベアリング  
**保護方法 /** 電流制限  
**使用温度範囲 /** -10°C~70°C  
**質量 /** 830g

**MATERIAL /**  
 HOUSING: Die-cast Aluminum  
 IMPELLER: Plastic (UL:V-0)  
**BEARING /** Ball Bearings  
**PROTECTION /** Current limit  
**OPERATING TEMP /** -10°C~70°C  
**MASS /** 830g

## ■外形図 External Dimensions

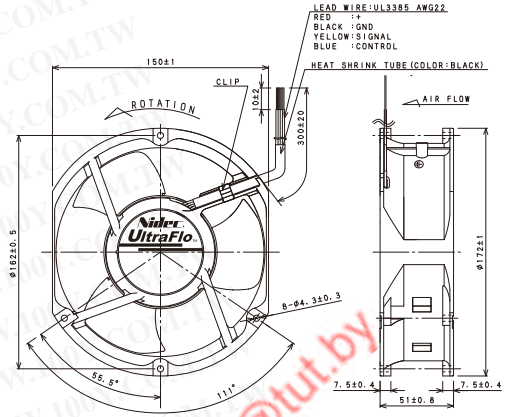

## ■取り付け穴参考寸法 Panel Out - Cuts

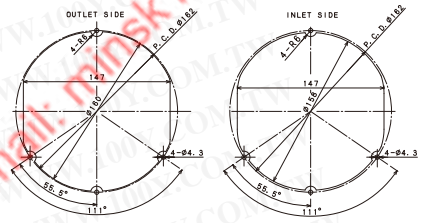

## ■特性 Major Characteristic Parameters

●フィードバック制御有り Feedback Control Design

Model	Rated Voltage	Operating Voltage range	Rated Current	Maximum Air Flow		Maximum Static Pressure		Rated Input Power	Sound Level	Rated Speed
	V	V	A	m <sup>3</sup> /min	CFM	Pa	inchH <sub>2</sub> O	W	dB (A)	min <sup>-1</sup>
X17L48BHM3-0*	48	30.0~60.0	0.94	10.11	357	424	1.70	45.12	63.5	4900
X17L48BGM3-0*	48	30.0~60.0	1.27	11.07	391	531	2.13	60.96	68.0	5400

(注) データは定格電圧での代表特性です。  
 Sound Levelは吸込側表面から1mにて測定した値です。  
 電源PWMは保証外とします。  
 電源の電圧リップルは定格電圧の±5%以下とします。  
 上記以外の定格電圧については、個別にお問い合わせ下さい。

(Note) The data shows typical value at rated voltage.  
 Sound Level is measured at the distance of one(1)meter from the axis of fan intake.  
 Insurance does not apply to power supply PWM.  
 The range of voltage ripples for power supply is ±5%.  
 Contact us on any rated voltage not listed above.

## ■特性グラフ P-Q Curve

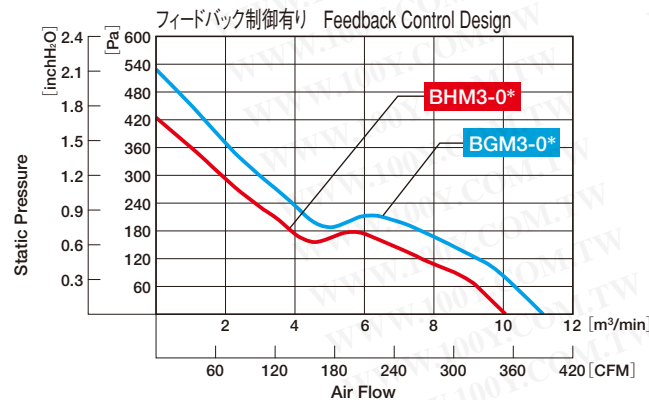

# φ172×150×51mm Series

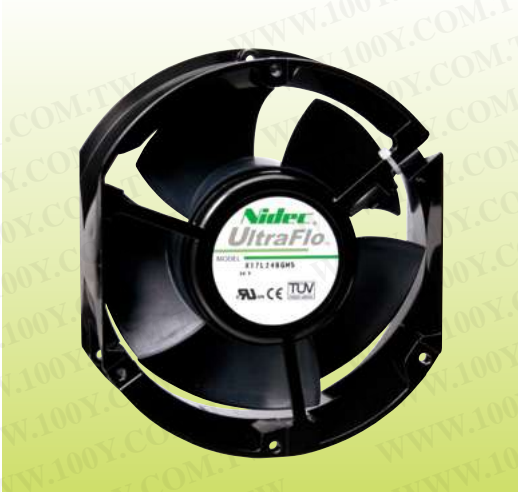

使用材料/  
ハウジング: アルミダイカスト  
インペラー: プラスチック (UL:V-0)  
軸受構造/ボールベアリング  
保護方法/電流制限  
使用温度範囲/−10°C~70°C  
質量/830g

MATERIAL/  
HOUSING: Die-cast Aluminum  
IMPELLER: Plastic (UL:V-0)  
BEARING/ Ball Bearings  
PROTECTION/ Current limit  
OPERATING TEMP/ −10°C~70°C  
MASS/ 830g

## ■外形図 External Dimensions

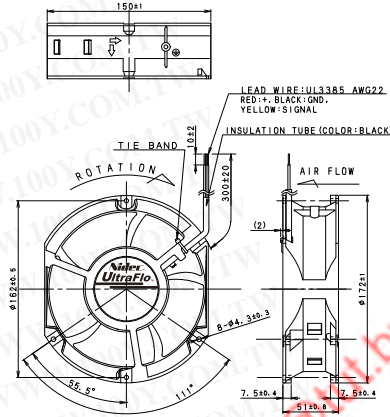

## ■取り付け穴参考寸法 Panel Out - Cuts

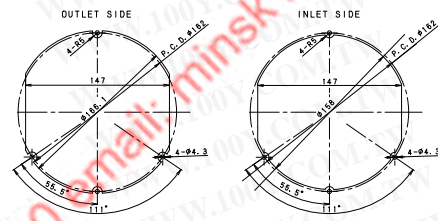

## ■特性 Major Characteristic Parameters

●フィードバック制御有り Feedback Control Design

Model	Rated Voltage	Operating Voltage range	Rated Current	Maximum Air Flow		Maximum Static Pressure		Rated Input Power	Sound Level	Rated Speed
	V	V	A	m <sup>3</sup> /min	CFM	Pa	inchH <sub>2</sub> O	W	dB (A)	min <sup>-1</sup>
X17L24BHM5-0*	24	12.0~27.6	0.95	7.15	252	330	1.33	22.80	57.5	3900
X17L24BGM5-0*	24	12.0~27.6	2.20	9.85	348	455	1.83	52.80	66.0	5300
X17L24BS1M5-0*	24	12.0~27.6	3.80	11.78	416	522	2.10	91.20	72.5	6400

(注) データは定格電圧での代表特性です。  
Sound Levelは吸込側表面から1mにて測定した値です。  
電源PWMは保証外とします。  
電源の電圧リップルは定格電圧の±5%以下とします。  
上記以外の定格電圧については、個別にお問い合わせ下さい。

(Note) The data shows typical value at rated voltage.  
Sound Level is measured at the distance of one(1)meter from the axis of fan intake.  
Insurance does not apply to power supply PWM.  
The range of voltage ripples for power supply is ±5%.  
Contact us on any rated voltage not listed above.

## ■特性グラフ P-Q Curve

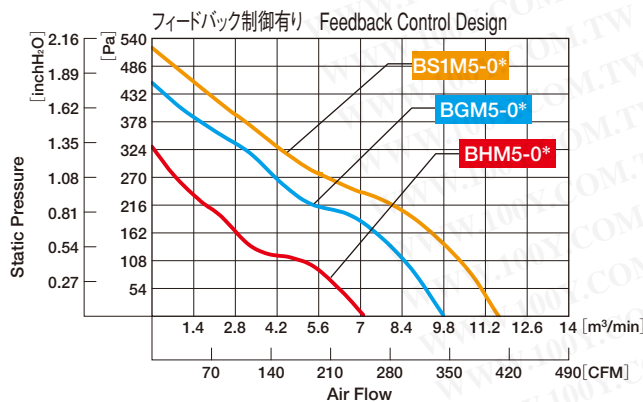

# φ172×150×51mm Series



使用材料/  
ハウジング: アルミダイカスト  
インペラー: プラスチック (UL:V-0)  
軸受構造/ボールベアリング  
保護方法/電流制限  
使用温度範囲/−10°C~70°C  
質量/830g

MATERIAL/  
HOUSING: Die-cast Aluminum  
IMPELLER: Plastic (UL:V-0)  
BEARING/ Ball Bearings  
PROTECTION/ Current limit  
OPERATING TEMP/ −10°C~70°C  
MASS/ 830g

## 外形図 External Dimensions

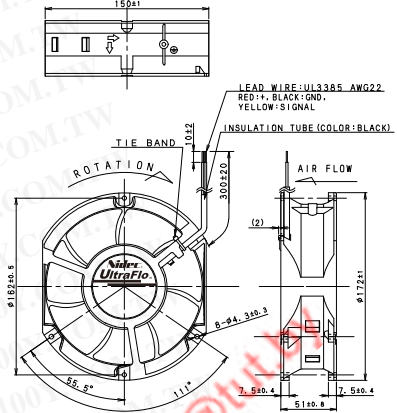

## 取り付け穴参考寸法 Panel Out - Cuts

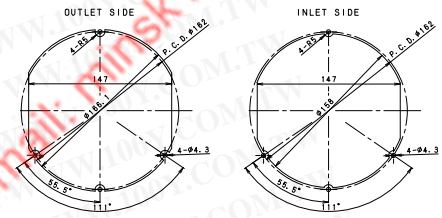

## 特性 Major Characteristic Parameters

●フィードバック制御有り Feedback Control Design

Model	Rated Voltage	Operating Voltage range	Rated Current	Maximum Air Flow		Maximum Static Pressure		Rated Input Power	Sound Level	Rated Speed
	V	V	A	m <sup>3</sup> /min	CFM	Pa	inchH <sub>2</sub> O	W	dB (A)	min <sup>-1</sup>
X17L24BHM7-0*	24	12.0~27.6	1.20	8.56	302	324	1.30	28.80	60.8	3900
X17L24BGM7-0*	24	12.0~27.6	3.10	11.92	421	385	1.55	74.40	73.0	5300

(注) データは定格電圧での代表特性です。  
Sound Levelは吸込側表面から1mにて測定した値です。  
電源PWMは保証外とします。  
電源の電圧リップルは定格電圧の±5%以下とします。  
上記以外の定格電圧については、個別にお問い合わせ下さい。

(Note) The data shows typical value at rated voltage.  
Sound Level is measured at the distance of one(1) meter from the axis of fan intake.  
Insurance does not apply to power supply PWM.  
The range of voltage ripples for power supply is ±5%.  
Contact us on any rated voltage not listed above.

## 特性グラフ P-Q Curve

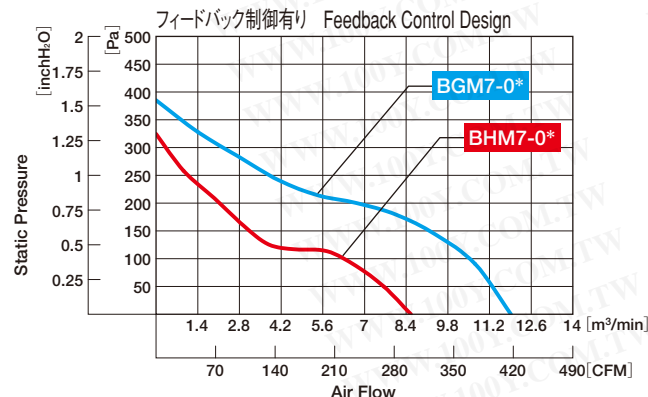

# φ 172×51 mm Series



使用材料/  
ハウジング: アルミダイカスト  
インペラー: プラスチック (UL:V-0)  
軸受構造/ボールベアリング  
保護方法/電流制限  
使用温度範囲/−10°C~70°C  
質量/850g

**MATERIAL**/  
HOUSING: Die-cast Aluminum  
IMPELLER: Plastic (UL:V-0)  
**BEARING**/Ball Bearings  
**PROTECTION**/Current limit  
**OPERATING TEMP**/−10°C~70°C  
**MASS**/850g

## ■外形図 External Dimensions

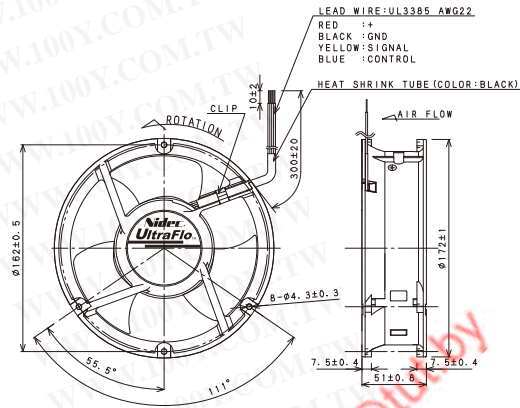

## ■取り付け穴参考寸法 Panel Out - Cuts

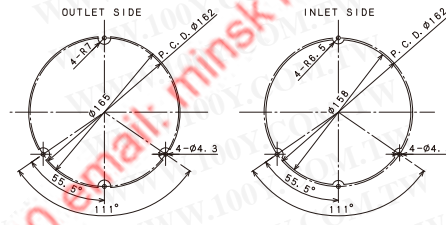

## ■特性 Major Characteristic Parameters

●フィードバック制御有り Feedback Control Design

Model	Rated Voltage	Operating Voltage range	Rated Current	Maximum Air Flow		Maximum Static Pressure		Rated Input Power	Sound Level	Rated Speed
	V	V	A	m <sup>3</sup> /min	CFM	Pa	inchH <sub>2</sub> O	W	dB (A)	min <sup>-1</sup>
Y17L48BHM3-0*	48	30.0~60.0	0.87	9.94	351	490	1.97	41.76	64.0	5000
Y17L48BGM3-0*	48	30.0~60.0	1.18	11.16	394	590	2.37	56.64	66.0	5600

(注) データは定格電圧での代表特性です。  
Sound Levelは吸込側表面から1mにて測定した値です。  
電源PWMは保証外とします。  
電源の電圧リップルは定格電圧の±5%以下とします。  
上記以外の定格電圧については、個別にお問い合わせ下さい。

(Note) The data shows typical value at rated voltage.  
Sound Level is measured at the distance of one(1) meter from the axis of fan inlet.  
Insurance does not apply to power supply PWM.  
The range of voltage ripples for power supply is ±5%.  
Contact us on any rated voltage not listed above.

## ■特性グラフ P-Q Curve

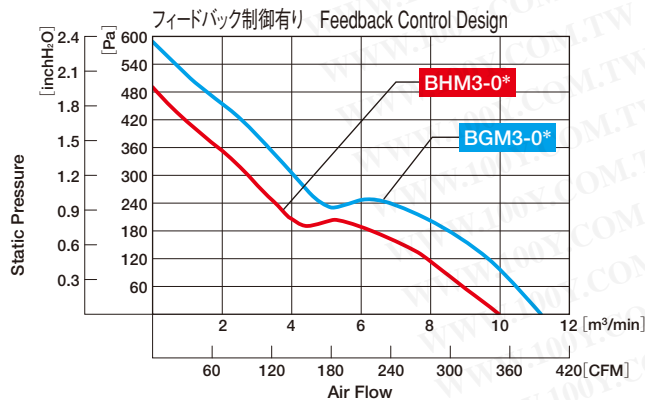

# 120×120×32mm Series



使用材料/  
ハウジング: プラスチック (UL:V-0)  
インペラー: プラスチック (UL:V-0)  
軸受構造/ボールベアリング  
保護方法/電流制限  
使用温度範囲/−10°C~70°C  
質量/340g

**MATERIAL/**  
HOUSING: Plastic (UL:V-0)  
IMPELLER: Plastic (UL:V-0)  
**BEARING/**Ball Bearings  
**PROTECTION/**Current limit  
**OPERATING TEMP/**−10°C~70°C  
**MASS/**340g

## 外形図 External Dimensions

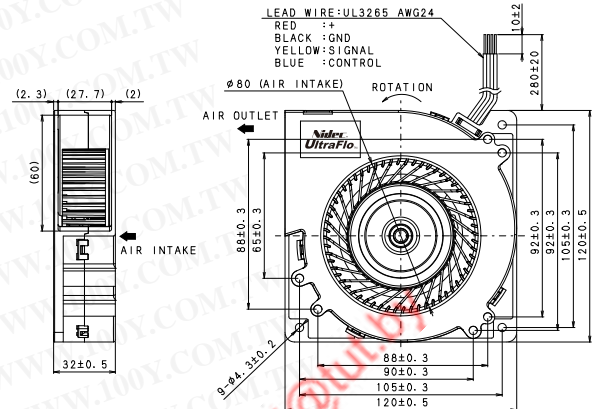

## 取り付け穴参考寸法 Panel Out - Cuts

上記外形図参照  
Refer to the External Dimensions above.

## 特性 Major Characteristic Parameters

●フィードバック制御無し Without Feedback Control Design

Model	Rated Voltage	Operating Voltage range	Rated Current	Maximum Air Flow		Maximum Static Pressure		Rated Input Power	Sound Level	Rated Speed
	V	V	A	m <sup>3</sup> /min	CFM	Pa	inchH <sub>2</sub> O	W	dB (A)	min <sup>-1</sup>
G12C12BHAZ-5*	12	7.0~13.8	2.70	1.62	57	810	3.25	32.40	61.0	4200
G12C12BGAZ-5*	12	7.0~13.8	3.63	1.77	62	966	3.88	43.56	64.0	4600

(注) データは定格電圧での代表特性です。  
Sound Levelは吸込側表面から1mにて測定した値です。  
電源PWMは保証外とします。  
電源の電圧リップルは定格電圧の±5%以下とします。  
上記以外の定格電圧については、個別にお問い合わせ下さい。

(Note) The data shows typical value at rated voltage.  
Sound Level is measured at the distance of one(1) meter from the axis of fan intake.  
Insurance does not apply to power supply PWM.  
The range of voltage ripples for power supply is ±5%.  
Contact us on any rated voltage not listed above.

## 特性グラフ P-Q Curve

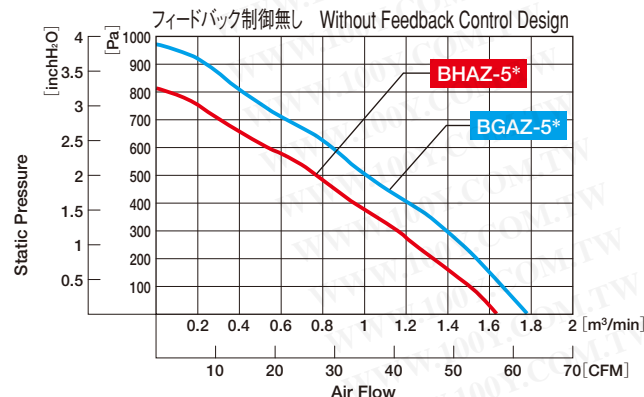

# 機種別機能別一覧表 UltraFlo™ Fans Matrix

型番 Model	使用電圧範囲 <sup>①</sup> Operating Voltage <sup>①</sup> range	軸受構造 Bearing Type		取り付け穴形状 <sup>②</sup> Flange Type <sup>②</sup>		アラーム信号、速度制御 <sup>③</sup> Alarm signal, Speed Control <sup>③</sup>			回路 Circuit		Page
		Ball Bearings	NBRX Type	フランジタイプ Open Flange	通し穴タイプ Closed Flange	Tachometer	Locked Rotor	PWM	フィードバック制御 Feedback Control Design	フィードバック制御無 Without Feedback Control Design	
U40X05MLZ7	4.25 ~ 5.75		●		●	▲	▲			▲	p.12
U40X05MMZ7	4.25 ~ 5.75		●		●	▲	▲			▲	
U40X05MHZ7	4.25 ~ 5.75		●		●	▲	▲			▲	
U40X12MLZ7	7.0 ~ 13.8		●		●	▲	▲			▲	
U40X12MMZ7	7.0 ~ 13.8		●		●	▲	▲			▲	
U40X12MHZ7	7.0 ~ 13.8		●		●	▲	▲			▲	
V40S12BLA5	7.0 ~ 13.8	●		●				▲		▲	p.13
V40S12BMA5	7.0 ~ 13.8	●		●				▲		▲	
V40S12BHA5	7.0 ~ 13.8	●		●				▲		▲	
V40S12BGA5	7.0 ~ 13.8	●		●				▲		▲	
V40S12BUA5	7.0 ~ 13.8	●		●				▲		▲	
V40S12BS4A5	7.0 ~ 13.8	●		●				▲		▲	
W40S12BLA5	7.0 ~ 13.8	●		●				▲		▲	
W40S12BMA5	7.0 ~ 13.8	●		●				▲		▲	
W40S12BHA5	7.0 ~ 13.8	●		●				▲		▲	
W40S12BGA5	7.0 ~ 13.8	●		●				▲		▲	
W40S12BUA5	7.0 ~ 13.8	●		●				▲		▲	
W40S12BS4A5	7.0 ~ 13.8	●		●				▲		▲	
R40W12BHAC	7.0 ~ 13.8	●		●				▲		▲	
R40W12BGAC	7.0 ~ 13.8	●		●				▲		▲	
R40W12BHCA	7.0 ~ 13.8	●		●				▲		▲	
R40W12BGCA	7.0 ~ 13.8	●		●				▲		▲	
U60R12MLAB	7.0 ~ 13.8		●		●	▲	▲			▲	p.16
U60R12MMAB	7.0 ~ 13.8		●		●	▲	▲			▲	
U60R12MHAB	7.0 ~ 13.8		●		●	▲	▲			▲	
U60R12MGAB	7.0 ~ 13.8		●		●	▲	▲			▲	
U60R12MUAB	7.0 ~ 13.8		●		●	▲	▲			▲	
U60T12MMA7	7.0 ~ 13.8		●		●	▲	▲			▲	p.17
U60T12MHA7	7.0 ~ 13.8		●		●	▲	▲			▲	
U60T12MGA7	7.0 ~ 13.8		●		●	▲	▲			▲	
U60T12MUA7	7.0 ~ 13.8		●		●	▲	▲			▲	
U60T12MS1A7	7.0 ~ 13.8		●		●	▲	▲			▲	
T60E12BLA5	7.0 ~ 13.8	●		●		●	●		●	●	p.18
T60E12BHA5	7.0 ~ 13.8	●		●		●	●		●	●	
T60E12BUA5	7.0 ~ 13.8	●		●		●	●		●	●	
V60E12BLA7	7.0 ~ 13.8	●		●		●	●		●	●	
V60E12BMA7	7.0 ~ 13.8	●		●		●	●		●	●	
V60E12BHA7	7.0 ~ 13.8	●		●		●	●		●	●	
V60E12BGA7	7.0 ~ 13.8	●		●		●	●		●	●	
V60E12BUA7	7.0 ~ 13.8	●		●		●	●		●	●	
V60E12HB5	7.0 ~ 13.8	●		●		●	●		●	●	
V60E12GB5	7.0 ~ 13.8	●		●		●	●		●	●	
U70R12MMCB	7.0 ~ 13.8		●		●	▲	▲			▲	p.21
U70R12MHCB	7.0 ~ 13.8		●		●	▲	▲			▲	
U70R12MS1CB	7.0 ~ 13.8		●		●	▲	▲			▲	
T70T12MLA9	7.0 ~ 13.8		●		●	▲	▲			▲	p.22
T70T12MMA9	7.0 ~ 13.8		●		●	▲	▲			▲	
T70T12MHA9	7.0 ~ 13.8		●		●	▲	▲			▲	
T70E12BLA5	7.0 ~ 13.8	●		●		●	●		●	●	p.23
T70E12BMA5	7.0 ~ 13.8	●		●		●	●		●	●	
T70E12BHA5	7.0 ~ 13.8	●		●		●	●		●	●	
T70E12BGA5	7.0 ~ 13.8	●		●		●	●		●	●	
T70E12BUA5	7.0 ~ 13.8	●		●		●	●		●	●	
U80R12MLAB	7.0 ~ 13.8		●		●	▲	▲			▲	p.24
U80R12MMAB	7.0 ~ 13.8		●		●	▲	▲			▲	
U80R12MHAB	7.0 ~ 13.8		●		●	▲	▲			▲	
T80T12MMA7	7.0 ~ 13.8		●		●	▲	▲			▲	p.25
T80T12MHA7	7.0 ~ 13.8		●		●	▲	▲			▲	
T80T12MGA7	7.0 ~ 13.8		●		●	▲	▲			▲	
T80T12MUA7	7.0 ~ 13.8		●		●	▲	▲			▲	
U80T12MMA7	7.0 ~ 13.8		●		●	▲	▲			▲	
U80T12MHA7	7.0 ~ 13.8		●		●	▲	▲			▲	p.25
U80T12MGA7	7.0 ~ 13.8		●		●	▲	▲			▲	
U80T12MUA7	7.0 ~ 13.8		●		●	▲	▲			▲	
H80E12BLA7	7.0 ~ 13.8	●		●		●	●		●	●	
H80E12BMA7	7.0 ~ 13.8	●		●		●	●		●	●	
H80E12BHA7	7.0 ~ 13.8	●		●		●	●		●	●	
H80E12BGA7	7.0 ~ 13.8	●		●		●	●		●	●	
H80E12BUA7	7.0 ~ 13.8	●		●		●	●		●	●	
V80E12BHA5	7.0 ~ 13.8	●		●		●	●		●	●	p.26
V80E12BS1A5	7.0 ~ 13.8	●		●		●	●		●	●	
V80E12BGA5	7.0 ~ 13.8	●		●		●	●		●	●	
V80E12BLA7	7.0 ~ 13.8	●		●		●	●		●	●	
V80E12BMA7	7.0 ~ 13.8	●		●		●	●		●	●	
V80E12BHA7	7.0 ~ 13.8	●		●		●	●		●	●	p.27
V80E12BGA7	7.0 ~ 13.8	●		●		●	●		●	●	
V80E12BUA7	7.0 ~ 13.8	●		●		●	●		●	●	
T92T12MMA7	7.0 ~ 13.8		●		●	▲	▲			▲	
T92T12MHA7	7.0 ~ 13.8		●		●	▲	▲			▲	
T92T12MGA7	7.0 ~ 13.8		●		●	▲	▲			▲	
T92T12MUA7	7.0 ~ 13.8		●		●	▲	▲			▲	
U92T12MMA7	7.0 ~ 13.8		●		●	▲	▲			▲	
U92T12MHA7	7.0 ~ 13.8		●		●	▲	▲			▲	
U92T12MGA7	7.0 ~ 13.8		●		●	▲	▲			▲	p.29
U92T12MUA7	7.0 ~ 13.8		●		●	▲	▲			▲	
H92C12BLA7	7.0 ~ 13.8	●		●		●	●		●	●	
H92C12BMA7	7.0 ~ 13.8	●		●		●	●		●	●	
H92C12BHA7	7.0 ~ 13.8	●		●		●	●		●	●	
H92C12BGA7	7.0 ~ 13.8	●		●		●	●		●	●	p.30
H92C12BGA7	7.0 ~ 13.8	●		●		●	●		●	●	
H92C12BUA7	7.0 ~ 13.8	●		●		●	●		●	●	
T92C12MMA7	7.0 ~ 13.8		●		●	▲	▲			▲	
T92C12MHA7	7.0 ~ 13.8		●		●	▲	▲			▲	
T92C12MGA7	7.0 ~ 13.8		●		●	▲	▲			▲	p.31
T92C12MUA7	7.0 ~ 13.8		●		●	▲	▲			▲	

型番 Model	使用電圧範囲 <sup>①</sup> Operating Voltage <sup>①</sup> range	軸受構造 Bearing Type		取り付け穴形状 <sup>②</sup> Flange Type <sup>②</sup>		アラーム信号、速度制御 <sup>③</sup> Alarm signal, Speed Control <sup>③</sup>			回路 Circuit		Page
		Ball Bearings	NBRX Type	フランジタイプ Open Flange	差し穴タイプ Closed Flange	Tachometer	Locked Rotor	PWM	フィードバック制御 Feedback Control Design	フィードバック制御無 Without Feedback Control Design	
									●	●	
T92E12BMA7	7.0 ~ 13.8	●		●		●	●	●	●	●	p.32
T92E12BHA7	7.0 ~ 13.8	●		●		●	●	●	●	●	
T92E12BGA7	7.0 ~ 13.8	●		●		●	●	●	●	●	
T92E12BUA7	7.0 ~ 13.8	●		●		●	●	●	●	●	p.33
V92E12BLA7	7.0 ~ 13.8	●		●		●	●	●	●	●	
V92E12BMA7	7.0 ~ 13.8	●		●		●	●	●	●	●	
V92E12BHA7	7.0 ~ 13.8	●		●		●	●	●	●	●	p.34
V92E12BGA7	7.0 ~ 13.8	●		●		●	●	●	●	●	
V92E12BUA7	7.0 ~ 13.8	●		●		●	●	●	●	●	
T12E48BHM7	30.0 ~ 60.0	●		●		●	●	●	●	●	p.35
T12E48BGM7	30.0 ~ 60.0	●		●		●	●	●	●	●	
V12E12BHB5	10.2 ~ 13.8	●		●		●	●	●	●	●	
V12E12GB5	10.2 ~ 13.8	●		●		●	●	●	●	●	p.36
V12E12BLM9	10.2 ~ 13.8	●		●		●	●	●	●	●	
V12E12BMM9	10.2 ~ 13.8	●		●		●	●	●	●	●	
V12E12BHM9	10.2 ~ 13.8	●		●		●	●	●	●	●	p.37
V12E12BGM9	10.2 ~ 13.8	●		●		●	●	●	●	●	
V12E12BUM9	10.2 ~ 13.8	●		●		●	●	●	●	●	
X17L48BHM3	30.0 ~ 60.0	●		●		●	●	●	●	●	p.38
X17L48BGM3	30.0 ~ 60.0	●		●		●	●	●	●	●	
X17L24BHM5	12.0 ~ 27.6	●		●		●	●	●	●	●	
X17L24BGM5	12.0 ~ 27.6	●		●		●	●	●	●	●	p.39
X17L24BS1M5	12.0 ~ 27.6	●		●		●	●	●	●	●	
X17L24BHM7	12.0 ~ 27.6	●		●		●	●	●	●	●	
X17L24BGM7	12.0 ~ 27.6	●		●		●	●	●	●	●	p.40
Y17L48BHM3	30.0 ~ 60.0	●		●		●	●	●	●	●	
Y17L48BGM3	30.0 ~ 60.0	●		●		●	●	●	●	●	
G12C12BHAZ	7.0 ~ 13.8	●		●	●	●	●	●	●	●	p.41
G12C12BGAZ	7.0 ~ 13.8	●		●	●	●	●	●	●	●	

- ①電源PWMは保証外とします。  
電源の電圧リップルは定格電圧の±5%以下とします。  
②上記以外のフランジタイプに関しては、個別にお問い合わせ下さい。  
③アラーム信号、速度制御は選択対応可能です。

▲ Analog  
● Microprocessor

- ①Insurance does not apply to power supply PWM.  
The range of voltage ripples for power supply is ±5%.  
②Please ask us separately on any other flange types not listed above.  
③Alarm signal, Speed Control ; Different alarms are available upon request.

勝特力材料 886-3-5753170  
 胜特力电子(上海) 86-21-34970699  
 胜特力电子(深圳) 86-755-83298787  
[Http://www.100y.com.tw](http://www.100y.com.tw)

Заказ г.Минск viberg и тел. +375447584780 email: minsk77@yut.by

**NIDEC ULTRAFLO, Минск +375447584780 Viber email [minsk17@tut.by](mailto:minsk17@tut.by)  
[www.fotorele.net](http://www.fotorele.net) [www.tiristor.by](http://www.tiristor.by) tel.+375 29 758 47 80 МТС**

# nidec ultraflo

купить, продажа



**Электронные компоненты, радиодетали**

[где и как купить в Минске?](#)

каталог, описание, технические, характеристики, datasheet, параметры, маркировка, габариты, фото,  
nidec ultraflo, **аналог, замена**, вентилятор

**КАТАЛОГ вентиляторы**

# nidec ultraflo

**2020 МИНСК**