

Short form Catalogue 2014-2015

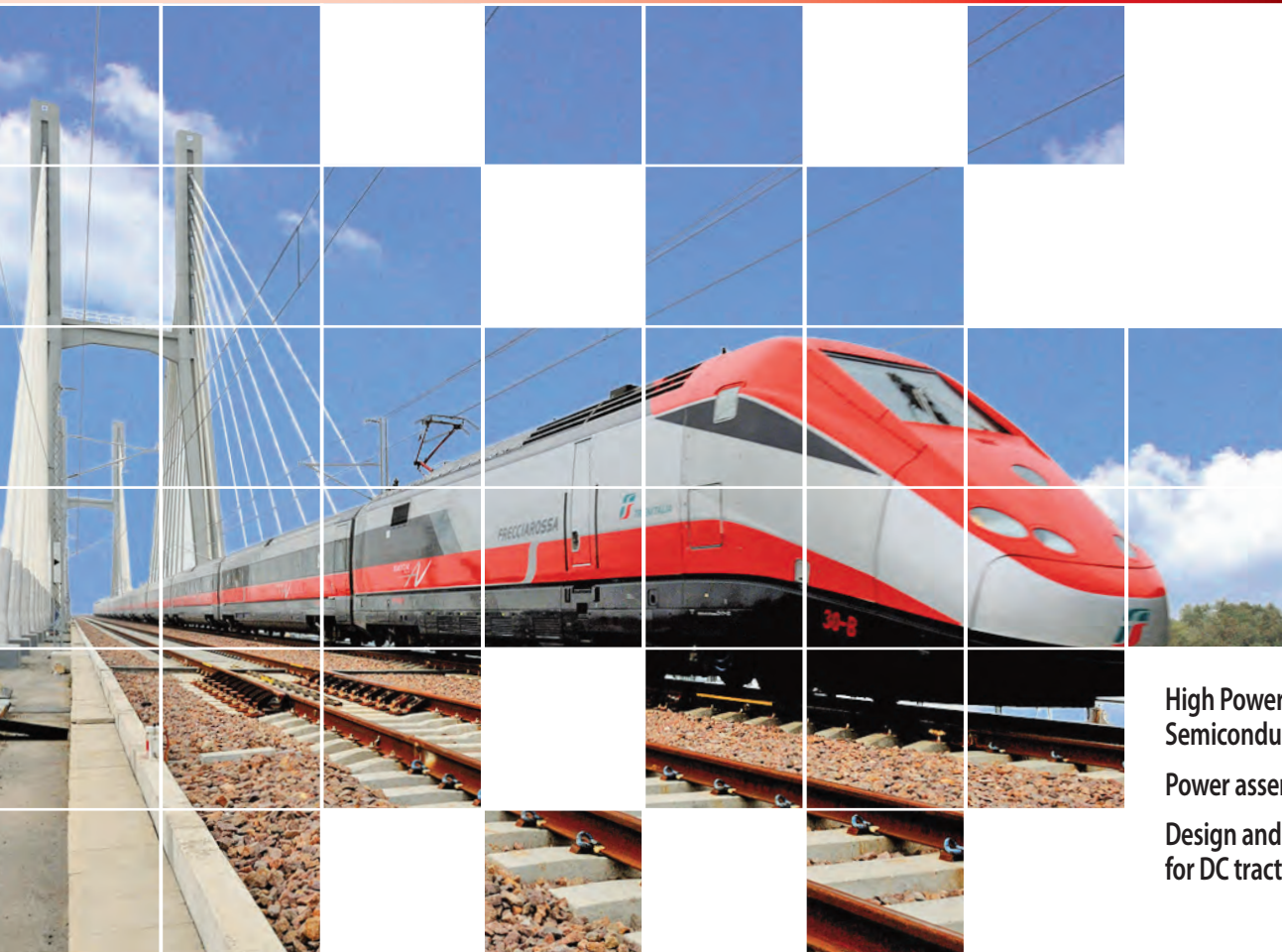

 **POSEICO**
POWER ELECTRONICS



High Power
Semiconductor Devices
Power assemblies and converters
Design and components
for DC traction substations



A Global Provider of products

Poseico was founded in 2001 as the Management Buy Out from the former Semiconductors Department of Ansaldo Trasporti that started its production of high power semiconductors in 1970. In a later stage, a development plan aimed at diversify its activities in different sectors has been defined, transforming Poseico into a global provider of products and services that can assist its clients in a wide range of sectors such as Energy, Transport, Infrastructure, Dams, Water Resources, Mining, Industry, Electrical and Mechanical Systems

design and manufacture of power electronics devices and systems

engineering consulting services



study, design, construction and maintenance of electrical and mechanical systems

The structural transformation and a continuous research are further significant evidences of the ability to approach to new projects in a serious and professional way, through the creation of pool of experts, ready to deal with new challenges in a market that is nowadays more and more selective

High Quality Performance



POSEICO SPA activity is dedicated to research, design, manufacturing and trade of high power semiconductors (diodes, thyristors, GTOs, PPIGBTs); accessories (heatsink, gate lead, etc) and to design, manufacture, trade and maintenance of power electronic converter including power assemblies and traction rectifiers.

POSEICO SPA is the MBO (Management Buy Out) Corporation issued in 2001 from the former Semiconductors Department of Ansaldo Trasporti that started its production in 1970. Throughout continuous improvement in technology, quality and reliability of its devices, it has been recognized as a leader firm in the high power semiconductors market. Poseico Spa Quality System has been certified, starting from 1993, at ISO9001 Standard.

POSEICO SPA policy is to continue developing new products with better performances, prices and services to cover as many applications as possible.



Environment Friendly Materials

The **POSEICO SPA** components:

Press - pack ceramic housing high power semiconductors devices
High power insulated modules

are conform to 2002/95/EC directive on the restriction of the use of certain hazardous substances in electrical and electronic equipment (RoHS).

Products standards

The **POSEICO SPA** components are conform to the following product standards:

High power semiconductors: IEC60747-01; IEC60747-02; IEC60747-06;
 Traction Rectifier Bridges: EN50328; IEC 60146-1; EN50163; EN50124

POSEICO Facilities	2
■ Press-Pack High Power Semiconductors	
POSEICO Advanced Technology	3
Rectifier Diodes	4
Welding Diodes	5
Phase Control Thyristors	6
Fast Recovery Diodes	8
Fast Recovery Diodes for IGBT's, IEGT's and IGTC's Applications	9
Fast Switching Thyristors	10
GTO and IGBT Press-Pack	11
Outlines	12
■ High Power Insulated Modules	
Rectifier Diode and Phase Control Thyristors Insulated Modules	16
Fast Recovery Diode Insulated Modules	17
High Current Rectifier Diode and Phase Control Thyristors Insulated Modules	18
Custom Insulated Modules	19
■ Accessories	
Gate Lead for Press-Pack Devices	20
Custom Gate Drivers and Snubber Circuits	21
■ Heatsinks and Cooling Systems	
Water Cooling Heatsinks	22
Forced Air Copper Heatsinks	24
Natural Air Heatsinks	26
■ Clamping Systems	
Bar Clamps	28
Insulated Solutions for Clamping Systems	30
Box Clamps	31
■ Power assemblies	
Power Assemblies	32
Water Cooling AC switches	34
■ Power Converters and Components for DC Traction Substations	
Power Conversion Products	36
Component for DC Traction Substations	37
Rectifier Bridges for Traction Applications	38
Voltage Limiting Devices (VLD-O type)	42
Disconnectors and Positive Cubicles	43
Power Converters	44
■ Maintenance Service	
Testing and Failure Analysis Services	46
Traction Refurbishment and Maintenance Services	47
List of Symbols	48
Mounting Recommendations	48
Maximum Allowable Average Current	48
Ordering Information	

Press-Pack High Power
Semiconductors

High Power
Insulated Modules

Accessories

Heatsinks and
Cooling systems

Clamping systems

Power assemblies

Power converters and components
for DC traction substations

Maintenance service

POSEICO, currently, has three sites for the manufacture of its products: two in **Italy** and one in **Romania**. Over 5000 square meters of covered area.

The **Research and Development Center and Design Department for High Power Press-Pack Devices** is located in the site of Genova.

The **Development and Design Department for Power Converters** is located in Busalla (20 Km near to Genova).



Headquarter - Diodes, Thyristors, GTOs and IGBTs design manufacture and testing via Pillea 42-44 Genova Italy



New facility (May 2011)
Power Rectifiers and Converters; Power assemblies;
Devices for Traction Substations
via Milite Ignoto 11 Busalla (20 km from Genova) Italy



POSEST Wafer fab plant
Zarnesti Parc Industrial Aleea Uzinei 1A
Brasov - Romania

POSEICO AZD1080S16, AZD1080S16,
Заказ Минск VIBER тел. +375 44 7584780 email minsk17@tut.by www.fotorele.net
радиодетали, электронные компоненты, каталог, описание, технические, характеристики,
datasheet, параметры, маркировка, габариты, фото, аналог, замена,

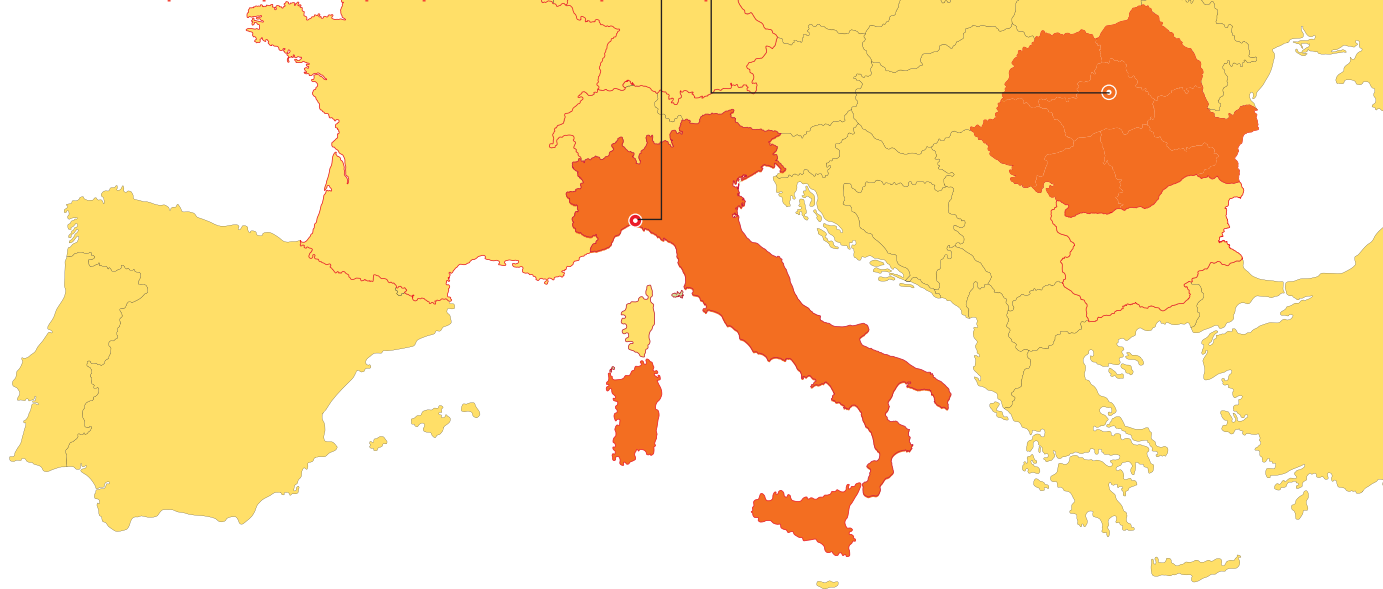

POSEICO advanced technologies for High Power Press Pack Semiconductors design and manufacturing



POSEICO design, manufacture and testing high power press pack semiconductors:

- Rectifier Diodes up to 6.0 kV and 9.6 kA
- Welding Diodes up to 1kV and 12 kA
- Phase Control Thyristors up to 6 kV and 6.4 kA
- Fast Recovery Diodes up to 5.6 kV and 3.7 kA
- Fast Recovery Diodes for IGBT's, IEGT's, GTC's applications up to 6 kV and 1.7 kA
- Fast Switching Thyristors up to 2.5 kV and 1.7 kA
- GTOs for traction applications 4.5 kV and 3.0 kA
- Press Pack IGBTs up to 4.5 kV and 1.2 kA
- Diode and Thyristor Modules up to 5.6 kV and 1.3 kA



Robust, hermetic sealed and reliable devices

Standard High Power Press Pack Semiconductors produced by POSEICO are assembled in a high reliable, robust and hermetic sealed ceramic housing. All the Insulated Modules produced by POSEICO uses high reliable pressure contact technology (PCT); the semiconductors are assembled and tested in a individual plastic case to increase the products reliability. POSEICO devices are operating in the field from more than 40 years. All device's types are still in production upto now, and spare parts can be supplied.



High Quality Control and High Performances

POSEICO offers a large range of devices optimized for different applications. The routine tests are performed on 100% of devices produced. Test reports can be supplied on request. Customized Test on request. Large capability of equipments for homologation, type and realibility tests of High Power Semiconductors. Cross reference service. Full equivalent devices for obsolete types. Failure Analysis Service. Design, manufacturing , testing and service conform to ISO9001:2008 and IRIS Rev2.

High Power Semiconductors optimized for Power Electronics applications:

- Traction
- Drives
- Conversion of energy
- Renewable Energies (Solar, Wind)
- Induction Heating
- UPS
- Welding

Main characteristics

IEC 64747-2 Standard
 High Reliable Devices in Press Pack Case
 Possibility of Parallel and Serie Connection
 Low Frequency Application
 Junction Temperature Range: 150 ÷ 190 °C



Rectifier diodes	V _{RRM}	I _{F(AV)} sine wave 50 Hz T _h =55°C	I _{FSM} sine wave 10 ms Vr<10V	I ² t T _{Jmax}	T _{Jmax}	V _{F(TO)} T _{Jmax}	r _F T _{Jmax}	R _{th(j-h)} Double side R _{thDC} = R _{th} 180 sin	R _{th(j-h)} Double side R _{th} 120 sin	F min/max suggested range	Outline
	[V]	[A]	[kA]	[A ² •s•10 ³]	[°C]	[V]	[mΩ]	[°C/kW]	[°C/kW]	[kN]	
up to 1000 V											
AR302	800	1570	16,0	1280	190	0,75	0,250	50,0	55,7	8.0 / 9.0	B0
AR1101	1000	2250	28,0	3920	175	0,75	0,125	37,0	41,2	11.8/13.2	C1
AR3001	1000	4655	44,8	10035	190	0,75	0,055	21,0	23,4	22.0/24.5	D2
AR609	600	5380	50,4	12701	190	0,73	0,035	21,0	23,4	22.0/24.5	D2
AR3001LT	1000	5835	50,4	12701	190	0,75	0,055	15,0	16,7	22.0/24.5	F0
AR709	1000	8710	85,0	36125	190	0,70	0,033	11,0	12,2	46.0/54.0	M0
AR709LT	1000	9600	85,0	36125	190	0,70	0,033	9,5	10,6	46.0/54.0	N0
up to 1800 V											
AR320	1800	1315	10,5	551	175	0,82	0,310	50,0	55,7	8.0/9.0	B0
AR420	1800	1750	18,5	1711	175	0,81	0,240	37,0	41,2	11.8/13.2	C1
AR520	1800	2620	31,0	4805	175	0,79	0,150	26,0	28,9	18.0/20.0	D1
up to 3000 V											
AR242	2200	830	6,5	211	175	0,70	0,400	95,0	105,9	4.5 / 5.0	A2
AR904	2900	1230	10,1	510	175	0,87	0,330	52,0	57,9	8.4/9.4	C0
AR340	2900	1265	10,1	510	175	0,87	0,330	50,0	55,7	8.0/9.0	B0
AR1104	2900	1680	17,9	1602	175	0,85	0,260	37,0	41,2	11.8/13.2	C1
AR3007	3000	2300	30,2	4560	150	0,87	0,127	26,0	28,9	18.0/20.0	D1
AR447PC	2400	2395	18,0	1620	175	0,85	0,260	21,0	23,4	11.8/13.2	P2
AR2004	2600	2525	28,0	3920	175	0,80	0,165	26,0	28,9	18.0/20.0	D1
AR3008	3000	2700	30,2	4560	175	0,87	0,127	26,0	28,9	18.0/20.0	D1
AR2004LT	2600	3180	33,6	5645	175	0,80	0,165	18,0	20,1	22.0/24.5	G0
AR3004	2600	3345	35,3	6230	175	0,80	0,110	21,0	23,4	22.0/24.5	D2
AR649	2500	4645	45,0	10125	175	0,70	0,100	14,0	15,6	35.0/40.0	H0
AR749	2500	4760	70,0	24500	175	0,65	0,140	11,0	12,2	46.0/54.0	M0
AR749LT	2500	5180	70,0	24500	175	0,65	0,140	9,5	10,6	46.0/54.0	N0
AR748LT	2600	6545	70,0	24500	175	0,80	0,070	9,5	10,6	46.0/54.0	N0
AR747LT	2600	6910	70,0	24500	175	0,72	0,065	9,5	10,6	46.0/54.0	N0
up to 4500 V											
AR372X	4500	572	5,0	125	150	0,95	1,500	52,0	58,0	8.4/9.4	C0
AR372	3200	705	5,6	157	150	1,00	0,920	50,0	55,7	8.0/9.0	B0
AR371X	4500	866	5,6	157	150	0,70	0,660	52,0	58,0	8.4/9.4	C0
AR371	3400	920	5,6	157	150	0,70	0,660	50,0	55,7	8.0/9.0	B0
AR1109	4400	1000	10,3	530	150	0,89	0,675	37,0	41,2	11.8/13.2	C1
AR1107	3600	1215	13,4	898	150	0,73	0,463	37,0	41,2	11.8/13.2	C1
AR2009	4400	1560	18,5	1711	150	0,83	0,393	26,0	28,9	18.0/20.0	D1
AR670	4000	2280	22,0	2420	150	0,80	0,210	21,0	23,4	22.0/24.5	D2
AR679	4500	3025	30,0	4500	150	0,75	0,200	14,0	15,6	35.0/40.0	H0
AR771HT	4500	3680	50,0	12500	150	0,80	0,170	11,0	12,2	46.0/54.0	R0
AR770	4500	3870	50,0	12500	150	0,80	0,150	11,0	12,2	46.0/54.0	M0
AR770HT	4500	3870	50,0	12500	150	0,80	0,150	11,0	12,0	46.0/54.0	R0
AR772HT	4500	4175	45,0	10125	175	0,75	0,180	11,0	12,2	46.0/54.0	R0
AR770LT	4500	4230	50,0	12500	150	0,80	0,150	9,5	10,6	46.0/54.0	N0
up to 6000 V											
AR912	5600	645	6,3	198	150	1,00	1,150	52,0	57,9	8.4/9.4	C0
AR480	6000	873	8,0	320	150	1,00	0,900	37,0	41,2	11.8/13.2	C1
AR680	6000	1693	20,0	2000	150	1,00	0,400	21,0	23,4	22.0/24.5	D2
AR690	6000	2437	18,0	1620	150	0,98	0,300	14,0	15,6	35.0/40.0	H0
AR771	5000	3680	50,0	12500	150	0,80	0,170	11,0	12,2	46.0/54.0	M0
AR771LT	5000	3690	50,0	12500	150	0,80	0,170	9,5	10,6	46.0/54.0	N0
AR772	5000	4175	45,0	10125	175	0,76	0,180	11,0	12,2	46.0/54.0	M0

Notes I_{FSM} (60 Hz) = 1.066 x I_{FSM} (50Hz) I²t (60Hz) = 0.9:3 x i²t (50Hz)

Main characteristics

- Optimized diodes for welding application
- Optimized for thermal management
- Junction temperature range : 170 ÷ 190 °C
- Possibility of parallel and serie connection
- Low frequency application
- Low voltage drop

Welding diodes	V_{RRM}	$I_{F(AV)}$ sine wave 50 Hz $T_c=85^\circ\text{C}$	I_{FSM} sine wave 10 ms $V_r < 10V$	I^2t $T_j \text{ max}$	$T_{j \text{ max}}$	$V_{F(TO)}$ $T_{j \text{ max}}$	r_F $T_{j \text{ max}}$	$R_{th(j-c)}$	F min/max suggested range	Outline
	[V]	[A]	[kA]	[A ² •s•10 ³]	[°C]	[V]	[mΩ]	[°C/kW]	[kN]	

Standard Hermetic Ceramic Housing



AR302	800	1680	16,0	1280	190	0,75	0,250	35,0	8.0 / 9.0	B0
AR1101	1000	2130	28,0	3920	175	0,75	0,125	30,0	11.8/13.2	C1
AR3001	1000	4930	44,8	10035	190	0,75	0,055	15,0	22.0/24.5	D2
AR609	600	5720	50,4	12701	190	0,73	0,035	15,0	22.0/24.5	D2
AR709LT	1000	9500	85,0	36125	190	0,70	0,033	7,5	46.0/54.0	N0

Thin Hermetic Ceramic Housing



AR507LT	600	3700	30,2	4560	175	0,87	0,127	12,0	20.0/22.0	P0
AR509LT	600	5520	50,0	12500	190	0,70	0,065	12,0	22.0/24.5	P0
AR508LT	600	6400	55,0	15125	190	0,70	0,040	12,0	20.0/22.0	P0
AR3001LT	1000	6460	50,4	12701	190	0,75	0,055	10,0	22.0/24.5	F0
AR609LT	600	7585	60,0	18000	190	0,73	0,035	10,0	22.0/24.5	F0
AR608LT	400	11385	80,0	32000	175	0,75	0,025	4,3	25.0/30.0	F1

Plastic Case



AR409PC	600	3865	30,0	4500	190	0,75	0,125	14,0	11.8/13.2	P2
AR509PC	600	5520	50,0	12500	190	0,70	0,065	12,0	20.0/22.0	P1
AR508PC	600	6400	55,0	15125	190	0,70	0,040	12,0	20.0/ 22.0	P1

Without Housing Ultrathin Device



AUS301	600	2815	16,0	1280	190	0,75	0,250	15,0	8.0/15.0	S1
AUS501HF*	600	6700	45,0	10125	190	0,84	0,050	14,0	25.0/50.0	S2
AUS501	600	7890	55,0	15125	190	0,70	0,040	9,0	25.0/50.0	S2
AUS603	600	12326	75,0	28125	190	0,70	0,027	6,0	35.0/65.0	S3

(*)Special design for high frequency applications:

$$t_{rr} = 3 \mu\text{s} \quad Q_{rr} = 1000 \mu\text{C}$$

$$I_{RR} = 700 \text{ A} @ I_F = 300 \text{ A}; dI_F/dT = 300 \text{ A}/\mu\text{s}; V_R = 100 \text{ V}$$

Phase Control Thyristors



Main characteristics

- IEC 60747-6 standard
- High reliable device in press pack case
- Possibility of parallel and serie connection
- Line Frequency Application
- Junction temperature range: 120 ÷ 150 °C

Phase control thyristors	V_{RRM} V_{DRM}	$I_{T(AV)}$ sine wave 50 Hz $T_n=55^\circ\text{C}$	I_{TSM} sine wave 10 ms $V_r < 10\text{V}$	I^2t T_{jmax}	(di/dt)	(dv/dt)	V_{GT} $T_j=25^\circ\text{C}$	I_{GT}	$V_{T(T0)}$ T_{jmax}	r_T T_{jmax}	T_{jmax}	$R_{th(j-h)}$ Double side 180° / 120° sin	F	Outline
	[V]	[A]	[kA]	[A ² •s•10 ³]	[A/μs]	[V/μs]	[V]	[mA]	[V]	[mΩ]	[°C]	[°C/kW]	[kN]	

up to 1000 V

AT202	800	635	6,00	180	320	500	3,5	200	0,80	0,49	150	95 / 105,9	4.9/5.9	A1
AT302	800	995	11,50	661	200	500	3,5	200	0,80	0,45	150	50 / 55,7	8.0/9.0	B0
AT303	800	1100	12,00	720	200	500	3,5	200	0,80	0,34	150	50 / 55,7	8.0/9.0	B0
AT607	800	2585	36,00	6480	200	500	3,5	200	0,80	0,12	140	21 / 23,4	22.0/24.5	D2
AT706	800	4305	70,00	24500	320	500	3,5	250	0,84	0,06	125	11 / 12,2	40.0/50.0	M0
AT706HT	800	4305	70,00	24500	320	500	3,5	250	0,84	0,06	125	11 / 12,2	40.0/50.0	R0
AT706LT	800	4765	70,00	24500	320	500	3,5	250	0,84	0,06	125	9,5 / 10,6	40.0/50.0	N0
AT708	800	4925	70,00	24500	320	500	3,5	250	0,84	0,06	140	11 / 12,2	40.0/50.0	M0
AT708HT	800	4925	70,00	24500	320	500	3,5	250	0,84	0,06	140	11 / 12,2	40.0/50.0	R0
AT708LT	800	5440	70,00	24500	320	500	3,5	250	0,84	0,06	140	9,5 / 10,6	40.0/50.0	N0
AT906	800	5600	95,00	45125	200	1000	3,5	400	0,85	0,05	125	8,5 / 9,5	80.0/100.0	Z0
AT908	800	6400	95,00	45125	200	1000	3,5	400	0,85	0,05	140	8,5 / 9,5	80.0/100.0	Z0

up to 1800 V

AT405	1200	305	2,80	39	200	500	3,5	200	1,00	1,90	125	95 / 105,9	4.9/5.9	A1
AT403	1200	400	5,00	125	200	500	3,5	200	1,00	0,85	125	95 / 105,9	4.9/5.9	A1
AT505	1600	430	5,60	157	200	500	3,5	200	1,00	0,68	125	95 / 105,9	4.9/5.9	A1
AT503	1600	445	6,40	205	200	500	3,5	200	0,90	0,68	125	95 / 105,9	4.9/5.9	A1
AT604	1600	605	8,40	353	200	500	3,5	200	1,05	0,85	125	50 / 55,7	8.0/9.0	B0
AT704	1600	640	8,00	320	200	500	3,5	200	0,86	0,79	125	52 / 57,9	8.0/9.0	C0
AT603	1600	720	8,80	387	200	500	3,5	200	0,91	0,58	125	50 / 55,7	8.0/9.0	B0
AT804	1600	985	12,50	781	200	500	3,5	250	1,00	0,38	125	37 / 41,2	11.8/13.2	C1
AT803	1600	1060	15,00	1125	200	500	3,5	150	0,90	0,34	125	37 / 41,2	11.8/13.2	C1
AT1005	1800	1450	22,40	2509	200	500	3,5	300	0,92	0,26	125	26 / 28,9	18.0/20.0	D1
AT1004	1600	1545	24,60	3026	200	500	3,5	300	0,92	0,22	125	26 / 28,9	18.0/20.0	D1
AT1003	1600	1650	26,90	3618	200	500	3,5	300	0,82	0,20	125	26 / 28,9	18.0/20.0	D1
AT636	1800	1965	36,00	6480	200	500	3,5	300	0,82	0,18	125	21 / 23,4	22.0/24.5	D2
AT620	1400	2100	36,00	6480	200	500	3,5	300	0,81	0,15	125	21 / 23,4	22.0/24.5	D2
AT726	1600	2400	38,00	7220	200	500	3,5	200	0,77	0,16	125	17 / 18,9	40.0/50.0	L0
AT720HT	1400	3950	60,00	18000	200	1000	3,5	350	0,88	0,08	125	11 / 12,2	40.0/50.0	R0
AT720LT	1400	4365	60,00	18000	200	1000	3,5	350	0,88	0,08	125	9,5 / 10,6	40.0/50.0	N0

up to 2800 V

AT333	2400	660	7,50	281	200	500	3,5	300	0,95	0,72	125	50 / 55,7	8.0/9.0	B0
AT807	2400	835	10,00	500	200	500	3,5	250	1,12	0,55	125	37 / 41,2	11.8/13.2	C1
AT1007	2600	1270	19,00	1805	200	500	3,5	300	1,15	0,31	125	26 / 28,9	18.0/20.0	D1
AT655	2800	1545	30,00	4500	200	500	3,5	300	1,05	0,29	125	21 / 23,4	22.0/24.5	D2
AT646	2200	1730	36,00	6480	200	500	3,5	300	0,90	0,24	125	21 / 23,4	22.0/24.5	D2
AT746	2600	1795	25,00	3125	200	500	3,5	300	1,10	0,27	125	17 / 18,9	40.0/50.0	L0
AT847	2500	2980	39,20	7683	800	1000	3,5	400	0,85	0,18	125	11 / 12,2	40.0/50.0	M0
AT847HT	2500	2980	39,20	7683	800	1000	3,5	400	0,85	0,18	125	11 / 12,2	40.0/50.0	R0
AT737	2000	3240	50,40	12701	200	500	3,5	350	0,95	0,13	125	11 / 12,2	40.0/50.0	M0
AT737HT	2000	3240	50,40	12701	200	500	3,5	350	0,95	0,13	125	11 / 12,2	40.0/50.0	R0
AT847LT	2500	3265	39,20	7683	800	1000	3,5	400	0,85	0,18	125	9,5 / 10,6	40.0/50.0	N0
AT737LT	2000	3565	50,40	12701	200	500	3,5	350	0,95	0,13	125	9,5 / 10,6	40.0/50.0	N0
AT738	2200	3670	60,00	18000	200	500	3,5	350	0,92	0,09	125	11 / 12,2	40.0/50.0	M0
AT738HT	2200	3670	60,00	18000	200	500	3,5	350	0,92	0,09	125	11 / 12,2	40.0/50.0	R0
AT738LT	2200	4050	60,00	18000	200	500	3,5	350	0,92	0,09	125	9,5 / 10,6	40.0/50.0	N0
AT940	2800	4595	75,00	28125	200	1000	3,5	400	1,00	0,07	125	8,5 / 9,5	80.0/100.0	Z0

Press-Pack High Power Semiconductors

High Power Insulated modules

Accessories

Heatinks and Cooling systems

Clamping systems

Power assemblies

Power converters and components for DC traction substations

Maintenance service

Phase control thyristors	V_{RRM} V_{DRM}	$I_{T(AV)}$ sine wave 50 Hz $T_h=55^\circ\text{C}$	I_{TSM} sine wave 10 ms $V_r < 10\text{V}$	I^2t T_{jmax}	(di/dt)	(dv/dt)	V_{GT} I_{GT} $T_j=25^\circ\text{C}$	$V_{T(T0)}$ T_{jmax}	r_T T_{jmax}	T_{jmax}	$R_{th(j-h)}$ Double side 180° / 120° sin	F	Outline
	[V]	[A]	[kA]	[A ² •s•10 ³]	[A/μs]	[V/μs]	[V] [mA]	[V]	[mΩ]	[°C]	[°C/kW]	[kN]	
up to 4500 V													
AT818	4000	580	5,90	174	200	500	3,5 200	1,35	1,34	125	37 / 41,2	11.8/13.2	C1
AT671	4500	1085	13,00	845	400	1000	3,5 400	1,20	0,70	125	21 / 23,4	22.0/24.5	D2
AT1228	3200	1275	20,00	2000	200	1000	3,5 300	1,20	0,45	125	21 / 23,4	22.0/24.5	D2
AT875	4400	2000	25,20	3175	200	1000	3,5 400	1,30	0,33	120	11 / 12,2	40.0/50.0	M0
AT875HT	4400	2000	25,20	3175	200	1000	3,5 400	1,30	0,33	120	11 / 12,2	40.0/50.0	R0
AT866	3600	2165	29,10	4234	200	1000	3,5 400	1,20	0,33	125	11 / 12,2	40.0/50.0	M0
AT866HT	3600	2165	29,10	4234	200	1000	3,5 400	1,20	0,33	125	11 / 12,2	40.0/50.0	R0
AT875LT	4400	2200	25,20	3175	200	1000	3,5 400	1,30	0,33	120	9,5 / 10,6	40.0/50.0	N0
AT866LT	3600	2375	29,10	4234	200	1000	3,5 400	1,20	0,33	125	9,5 / 10,6	40.0/50.0	N0
AT870	4200	2970	50,00	12500	200	1000	3,5 400	1,00	0,17	125	10,5 / 11,7	60.0/80.0	M0

up to 6000 V													
AT480	5800	527	4,50	101	200	500	3,5 200	1,30	1,76	125	37 / 41,2	8.0/9.0	C1
AT681	6000	840	10,00	500	100	500	3,5 400	1,30	1,15	120	21 / 23,4	22.0/24,5	D2
AT880	5200	2570	40,00	8000	200	1000	3,5 400	1,07	0,24	125	10,5 / 11,7	60.0/80.0	M0
AT980	6000	2680	50,00	12500	200	1000	3,5 400	1,30	0,24	120	8,5 / 9,5	80.0/100.0	Z0

Notes

$R_{th(j-h)} DC = R_{th(j-h)} 180^\circ \sin$

$I_{FSM} (60 \text{ Hz}) = 1.066 \times I_{FSM} (50 \text{ Hz})$

$I^2t (60 \text{ Hz}) = 0.943 \times I^2t (50 \text{ Hz})$

Gate terminal type AMP 60598-1

Cathode terminal type DIN 46244-A4.8-0.8

High Power insulated modules

Accessories

Heatinks and Cooling systems

Clamping systems

Power assemblies

Power converters and components for DC traction substations

Maintenance service

Fast Recovery Diodes

Main characteristics

IEC 64747-2 Standard
 High Reliable Device in Press Pack Case
 Possibility of Parallel and Serie Connection
 High Frequency Application
 Junction Temperature Range: 125 ÷ 150 °C



Fast recovery diodes	V _{RRM}	I _{F(AV)} sine wave 50 Hz T _n =55°C	I _{FSM} sine wave 10 ms V _r <10V	I ² t T _{Jmax}	T _{Jmax}	V _{F(T0)} T _{Jmax}	r _F T _{Jmax}	Recovery parameters			R _{th(j-h)} Double side 180°/120° sin	F min/max suggested range	Outline
								Q _{RR} T _{Jmax}	t _{RR} T _{Jmax}	Test conditions I _F / di/dt			

up to 1800 V

ARF221	1400	415	4,5	101	125	1,05	0,700	50	2,0	200/40	95/105,9	4.5/5.0	A2
ARF612	1500	425	3,8	72	150	1,15	1,141	210	4,0	200/50	95/105,9	4.5/5.0	A2
ARF220	1400	445	4,5	101	125	1,00	0,600	80	2,5	200/40	95/105,9	4.5/5.0	A2
ARF322	1600	740	11,0	605	125	0,90	0,500	60	2,0	1000/60	52/57,9	8.4/9.4	C0
ARF422	1600	940	14,0	980	125	1,20	0,350	200	3,5	1000/60	37/41,2	11.8/13.2	C1
ARF526	1600	1345	20,0	2000	125	1,00	0,300	250	3,5	1000/100	26/28,9	18.0/20.0	D1

up to 3300 V

ARF261	3300	125	3,0	45	125	2,30	12,000	45	1,0	200/100	95/105,9	4.5 / 5.0	A2
ARF260	3300	190	3,0	45	125	1,95	4,200	70	1,6	500/100	95/105,9	4.5 / 5.0	A2
ARF241	2500	255	3,0	45	150	1,75	3,200	50	1,4	200/80	95/105,9	4.5 / 5.0	A2
ARF240	2500	280	3,0	45	150	1,50	3,000	90	2,0	200/80	95/105,9	4.5 / 5.0	A2
ARF912	2600	755	6,4	205	150	1,15	0,685	260	4,0	350/80	52/57,9	8.4/9.4	C0
ARF340	2600	775	6,4	205	150	1,15	0,685	260	4,0	350/80	50/55,7	8.0/9.0	B0
ARF435	2600	955	12,0	720	150	1,10	0,675	360	4,0	500/80	37/41,2	11.8/13.2	C1
ARF565	3200	1215	14,0	980	150	1,50	0,500	1000	5,0	1000/100	26/28,9	18.0/20.0	D1
ARF2012	2600	1525	16,0	1280	150	1,03	0,362	800	4,6	1000/100	26/28,9	18.0/20.0	D1
ARF648	2500	2510	30,0	4500	150	0,85	0,300	1000	5,0	1000/250	14/15,6	35.0/40.0	H0
ARF744	2500	3725	48,0	11520	150	0,85	0,016	500	5,0	1000/60	11/12,2	46.0/54.0	M0

up to 4500 V

ARF370	4500	485	4,0	80	150	1,74	1,700	700	5,0	1000/100	52/57,9	8.4/9.4	C0
ARF463	4500	730	10,0	500	150	1,70	1,000	650	5,2	600/80	37/41,2	11.8/13.2	C1
ARF674	4500	945	15,0	1125	125	1,90	0,700	600	8,0	500/30	21/23,4	22.0/24.5	D0
ARF675	4500	1085	15,0	1125	125	1,70	0,700	1700	5,6	1000/250	18/20,0	22.0/24.5	G0
ARF677	4500	1370	18,0	1620	140	1,25	0,500	1150	7,0	500/80	21/23,4	22.0/24.5	D0
ARF676	4800	1515	18,0	1620	140	1,25	0,500	2000	6,0	1000/250	18/20,0	22.0/24.5	G0
ARF678	4500	1690	24,0	2880	150	1,30	0,650	1350	4,2	1000/250	14/15,6	35.0/40.0	H0
ARF774	4500	2325	26,0	3380	125	1,30	0,250	1500	8,6	1000/60	11/2,2	46.0/54.0	M0

up to 5600 V

ARF490	5600	655	9,5	451	125	1,50	0,870	1400	4,8	1000/200	37/41,2	11.8/13.2	C1
--------	------	-----	-----	-----	-----	------	-------	------	-----	----------	---------	-----------	----

Notes

R_{th(j-h)} DC=R_{th(j-h)} 180° sin
 I_{FSM} (60 Hz) = 1.066 x I_{FSM} (50Hz)
 I²t (60Hz) = 0.943 x I²t (50Hz)

Q_{rr} calculation: 25% chord (see drawing)

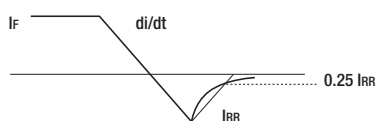

Fast Recovery Diodes for IGBT's, IEGT's and IGCT's Applications

Main characteristics

IEC 60747-2 standard
 High reliable device in press pack case
 Possibility of parallel and serie connection
 Suitable as freewheeling, snubber and clamp diode in IGCT and IGBT circuits

Snubberless operation
 Low losses
 Improved recovery softness
 High di/dt capability
 Junction temperature range: 125 ÷ 140 °C



Fast recovery diodes	V_{RRM}	$I_{F(AV)}$ sine wave 50 Hz $T_h=55^\circ\text{C}$	I_{FSM} sine wave 10 ms $V_r < 10V$	I^2t $T_{j\max}$	$T_{j\max}$	$V_{F(TO)}$ $T_{j\max}$	r_F $T_{j\max}$	Recovery parameters			$R_{th(j-h)}$ Double side 180°/120° sin	F min/max suggested range	Outline
								Q_{RR} $T_{j\max}$	t_{RR} $T_{j\max}$	Test conditions $I_F / di/dt$			
	[V]	[A]	[kA]	[A ² •s•10 ³]	[°C]	[V]	[mΩ]	[μC]	[μs]	[A]/[A/μs]	[°C/kW]	[kN]	

up to 3300 V

ARF360	3300	290	4,5	101	125	1,86	4,100	55	1,3	500/100	50/55,7	8.0/9.0	B0
ARF664	3300	935	18,0	1620	125	1,80	0,700	2000	3,6	2100/1100	21/23,4	22.0/24.5	D0

up to 4500 V

ARF462	4500	435	10,0	500	125	2,70	1,400	1150	2,6	1000/1000	37/41,2	11.8/13.2	C1
ARF671	4500	790	15,0	1125	125	1,90	1,100	2500	3,6	2100/1000	21/23,4	22.0/24.5	D0
ARF672	4500	935	15,0	1125	125	1,80	0,950	1600	2,9	2100/1100	18/20,0	22.0/24.5	G0
ARF673	4500	990	15,0	1125	125	1,70	0,850	2300	3,5	2100/1100	18/20,0	22.0/24.5	G0
ARF681	4500	1140	25,0	3125	125	1,95	0,800	2200	3,8	2100/1000	14/15,6	35.0/40.0	H0
ARF670	4500	1315	15,0	1125	140	1,50	0,600	2050	3,9	1000/500	18/20,0	22.0/24.5	G0
ARF771LT	4500	1730	28,0	3920	140	1,95	0,800	3500	4,7	2500/1000	9,5/10,6	46.0/54.0	N0

up to 6000 V

ARF694	6000	645	10,0	500	125	2,10	1,800	2000	3,5	2100/1000	21/23,4	22.0/24.5	D0
ARF695	6000	880	18,0	1620	125	2,10	1,550	3000	5,0	2100/1000	14/15,6	35.0/40.0	H0
ARF794HT	6000	1060	20,0	2000	125	2,10	1,400	4000	5,0	2500/1000	11/12,2	46.0/54.0	R0
ARF794LT	6000	1160	20,0	2000	125	2,10	1,400	4000	5,0	2500/1000	9,5/10,6	46.0/54.0	N0

Note

$$R_{th(j-h)} DC = R_{th(j-h)} 180^\circ \sin$$

Press-Pack High Power
Semiconductors

High Power insulated modules

Accessories

Heatsinks and
Cooling systems

Clamping systems

Power assemblies

Power converters and components
for DC traction substations

Maintenance service

Main characteristics

- IEC 64747-6 Standard
- High Reliable Device in Press Pack Case
- Low Switching Losses
- Possibility of Parallel and Serie Connection
- High Frequency Application
- Junction Temperature Range: 120 ÷ 125 °C



Symmetrical

Fast switching thyristors	V_{DRM} V_{DRM}	$I_{T(AV)}$ sine wave 50 Hz $T_R=55^\circ\text{C}$	I_{TSM} sine wave 10 ms $V_r < 10\text{V}$	(di/dt) crit $T_{j\text{max}}$	(dv/dt) crit $T_{j\text{max}}$	V_{GT} I_{GT} $T_j=25^\circ\text{C}$		$V_{T(TO)}$ $T_{j\text{max}}$	r_T $T_{j\text{max}}$	td	tq	Recovery parameter ($di/dt = 60 \text{ [A/}\mu\text{s]}$ IF 1000 [A])		$T_{j\text{max}}$	$R_{th(j-h)}$ Double side 180°/120° sin	F	Out-line
						I_{RR}	$Q_{RR\text{max}}$										
	[V]	[A]	[kA]	[A/μs]	[V/μs]	[V]	[mA]	[V]	[mΩ]	[μs]	[μs]	[A]	[μC]	[°C]	[°C/kW]	[kN]	

up to 1200

ATF587	1200	350	4,5	200	500	3,5	350	1,38	0,830	0,40	25	139	190	125	95/105,9	4.5/5	A0
ATF585	800	445	6,0	200	500	3,5	350	1,30	0,325	0,60	15	104	140	125	95/105,9	4.5/5	A0
ATF413	1200	705	9,0	500	600	3,5	350	1,55	0,650	0,85	12	75	80	125	37/41,2	11/13	C1
ATF860	1200	730	7,5	400	500	3,5	350	1,64	0,520	0,60	15	140	250	125	37/41,2	11/13	C1
ATF414	1200	805	10,0	500	600	3,5	350	1,50	0,430	0,85	15	100	120	125	37/41,2	11/13	C1
ATF857	1200	830	8,5	400	500	3,5	350	1,38	0,435	0,40	25	150	300	125	37/41,2	11/13	C1
ATF401	800	890	12,0	400	600	3,5	350	1,35	0,350	0,30	20	80	60	125	37/41,2	11/13	C1
ATF415	1200	920	10,0	500	600	3,5	350	1,38	0,300	0,85	20	150	200	125	37/41,2	11/13	C1
ATF514	1200	1100	16,0	500	600	3,5	350	1,50	0,350	0,85	20	105	130	125	26/28,9	14/17	D1
ATF515	1200	1330	16,0	500	600	3,5	350	1,20	0,250	0,85	25	140	230	125	26/28,9	14/17	D1
ATF614	1200	1355	20,0	800	600	3,5	350	1,36	0,328	0,85	20	100	120	125	21/23,4	17/21	D2
ATF615	1200	1625	20,0	800	600	3,5	350	1,25	0,200	0,85	25	140	230	125	21/23,4	17/21	D2

up to 1600

ATF427	1400	780	9,1	800	500	3,5	350	1,75	0,330	1,50	25	168	330	125	37/41,2	11/13	C1
ATF828	1600	845	10,0	400	600	3,5	350	1,30	0,450	0,60	35	180	360	125	37/41,2	11/13	C1
ATF827	1400	900	10,0	400	600	3,5	350	1,32	0,350	0,60	25	168	330	125	37/41,2	11/13	C1
ATF524	1600	1055	15,0	500	600	3,5	350	1,45	0,425	0,85	35	160	320	125	26/28,9	14/17	D1
ATF527	1400	1230	14,6	800	500	3,5	350	1,40	0,260	1,50	25	230	650	120	26/28,9	14/17	D1
ATF1047	1400	1305	16,0	500	600	3,5	350	1,32	0,230	0,60	30	230	650	125	26/28,9	14/17	D1

up to 2000

ATF820	2000	725	9,0	400	600	3,5	350	1,53	0,600	0,60	50	205	550	125	37/41,2	11/13	C1
ATF420	2000	800	8,2	800	500	3,5	350	1,20	0,590	1,50	55	205	550	125	37/41,2	11/13	C1
ATF1040	2000	1075	14,0	500	500	3,5	350	1,40	0,414	0,60	50	227	620	125	26/28,9	14/17	D1
ATF530	2000	1100	15,0	800	500	3,0	150	1,30	0,410	1,50	50	300	620	125	26/28,9	14/17	D1

up to 2500

ATF633	2100	1390	17,0	400	600	3,5	350	1,30	0,320	0,80	60	195	450	125	21/23,4	17/21	D2
ATF543	2500	1070	10,0	500	500	3,5	350	1,50	0,611	1,70	70	268	770	125	21/23,4	17/21	D2

Asymmetrical Fast Switching Thyristors

Fast switching thyristors	V_{DRM} I_{DRM}	V_{DRM} I_{DRM}	$I_{T(AV)}$ sine wave 50 Hz $T_h=55^\circ\text{C}$	I_{TSM} sine wave 10 ms $V_r < 10\text{V}$	(di/dt) crit $T_{j\text{max}}$	(dv/dt) crit $T_{j\text{max}}$	V_{GT} I_{GT} $T_j=25^\circ\text{C}$		$V_{T(TO)}$ $T_{j\text{max}}$	r_T $T_{j\text{max}}$	V_T $T_j=180^\circ\text{C}$ $I_T=2000\text{A}$	t d $T_j=25^\circ\text{C}$	t q $T_j=25^\circ\text{C}$	$T_{j\text{max}}$	$R_{th(j-h)}$ Double side 180° sin	F	Out-line
							[V]	[mA]									
	[V]	[mA]	[V]	[kA]	[A/μs]	[V/μs]	[V]	[mA]	[V]	[mΩ]	[μs]	[μs]	[μs]	[°C]	[°C/kW]	[kN]	
ATA646	2100	30	1100	14	300	500	2,5	300	1,40	0,40	2,35	2,20	55	125	26	14/17	D0
	200	1000															
ATA644	2800	20	1355	16	300	500	2,5	300	1,45	0,30	2,35	2,20	55	125	21	17/21	D0
	200	1000															

Note

$$R_{th(j-h)} \text{ DC} = R_{th(j-h)} \text{ 180}^\circ \text{ sin}$$

Main characteristics

- High Reliable Device in Press Pack Case
- Very Good Trade Off between Conduction and Switching losses
- Possibility of Parallel and Serie connection
- High Frequency Application
- Junction Temperature Range: 125 °C



GTOs

Type	V_{DRM}	V_{DRM}	$T_{j\ max}$	$I_{T(AV)}$ sine wave 50 Hz $T_h=75^\circ C$	I_{TSM}	(dv/dt) crit	V_{GT} I_{GT} $T_j=25^\circ C$		$V_{T(TO)}$ $T_{j\ max}$	r_T $T_{j\ max}$	tgt	td	(di/dt) crit	I_{TCM}	tgq	V_{DSP}	$R_{th(j-h)}$ double side RthDC= Rth 180° sin	F	Out- line
	[V] [mA]	[V] [mA]					[V]	[A]											
ATG777	4500	16	125	890	17	1000	1,5	3	1,51	0,51	10	3	400	2400	30	850	16	31/35	Q0
	100	10																	
ATG778	4500	16	125	760	17	1000	1,5	3	1,64	0,73	10	3	400	3000	30	950	16	31/35	Q0
	100	10																	

IGBTs Press - Pack

Type	$V_{CES\ max}$	$I_{CES\ max}$	$I_c\ max$	$I_{cm\ max}$	$V_{CE\ (SAT)}$ typ.	$I_F\ max$	V_{FM} typ.	t_{on} typ.	t_f typ.	t_{off} typ.	t_{rr} typ.	V_{GEth} typ.	$R_{th(j-h)}$ typ.	$R_{th(j-h)}$ typ.	$T_{j\ max}$	F min/ max	Out- line	Circuit configuration
	[V]	[mA]	[A]	[A]	[V]	[A]	[V]	[μs]	[μs]	[μs]	[μs]	[V]	[°C/kW]	[°C/kW]				
AGB1000S25	2500	200	1000	2000	5,5	1000	2,7	2,2	0,5	1,7	0,6	3,0/6,0	18	45	125	28,3/ 34,4	Q1	
AGB1200FIS45	4500	100	1200 ⁽⁴⁾	3000 ⁽⁵⁾	4,2	No diode inside			4,0	8,0	No diode inside	6,0	10 ⁽¹¹⁾	No diode inside	125	28,0 35,0	Z1	

Switching and recovery conditions:

AGB1000S25

- turn on
 $V_{CC}=1500$, $I_c=1000A$, $V_{GE}=15V$, $R_{GON}=5\Omega$, Inductive Load
- turn off
 $V_{CC}=1500$, $I_c=1000A$, $V_{GE}=15V$, $R_{GOFF}=5\Omega$, Inductive Load
- diode recovery
 $I_F=1000A$, $-di_f/dt=2600A/\mu s$, $V_{GE}=15V$

Switching conditions:

AGB1200FIS45

- turn on
 $V_{CC}=2600V$, $I_c=1500A$, $V_{GE}=15V$, $R_{GON}=7.5\Omega$, Inductive Load; $di_f/dt=2500A/\mu s$
- turn off
 $V_{CC}=2600V$, $I_c=1500A$, $V_{GE}=15V$, $R_{GOFF}=7.5\Omega$, Inductive Load; $-di_f/dt=2500A/\mu s$

(4) $V_{CE}=V_{CES}$; $V_{GE}=0V$

(5) $t_p=1\ \mu s$

(6) $V_{GE}=15V$

(7) $V_{GE}=0V$

(8) $V_{CE}=V_{GE}$

(9) 50 Hz, half sine wave, $T_h=75^\circ C$ without switching losses

(10) Peak turn-off $I_{cp}=3000A$ at $V_{cp}<3600V$; $V_{GE}=\pm 15V$, $R_G=7.5\Omega$, $T_j<125^\circ C$; non repetitive

(11) $R_{th(j-c)}$ value

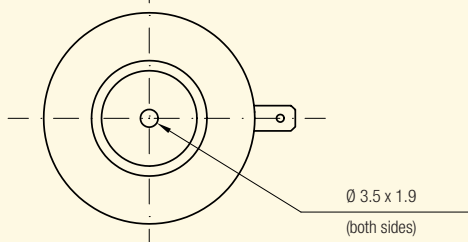
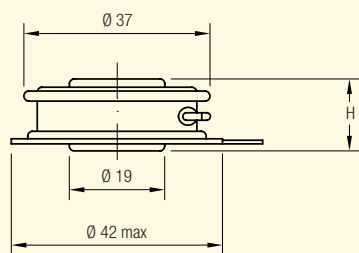
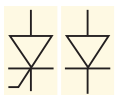

A0 H = 14±0.5 W = 55 gr.

A1 H = 14.3±0.5 W = 55 gr.

A2 H = 14.5±0.5 W = 55 gr.

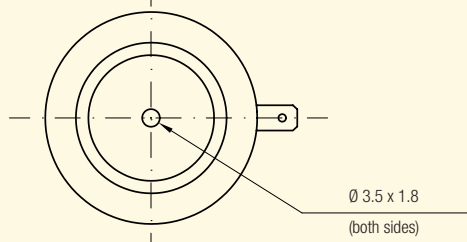
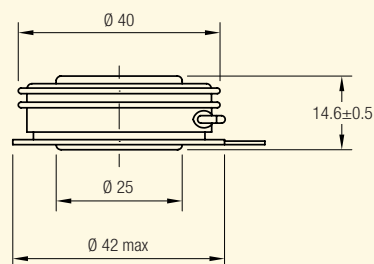
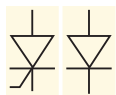

B0 W = 85 gr.

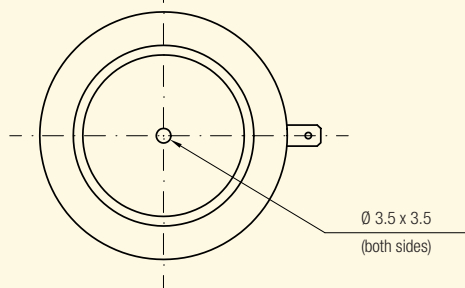
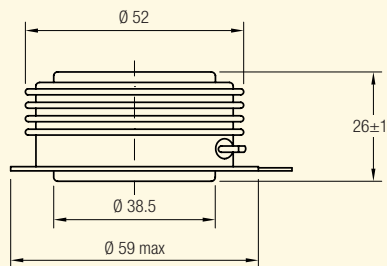
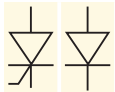

C0 W = 280 gr.

C1 W = 300 gr.

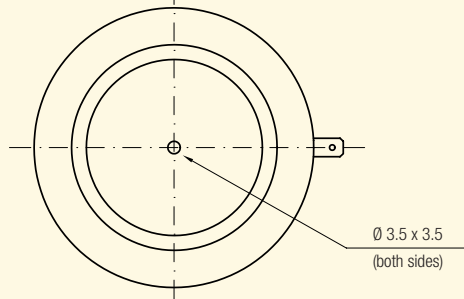
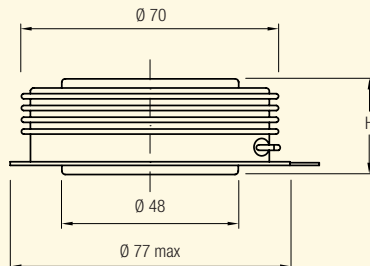
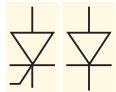

D0 H = 26±1 W = 500 gr.

D1 H = 27±1 W = 500 gr.

D2 H = 27±1 W = 520 gr.

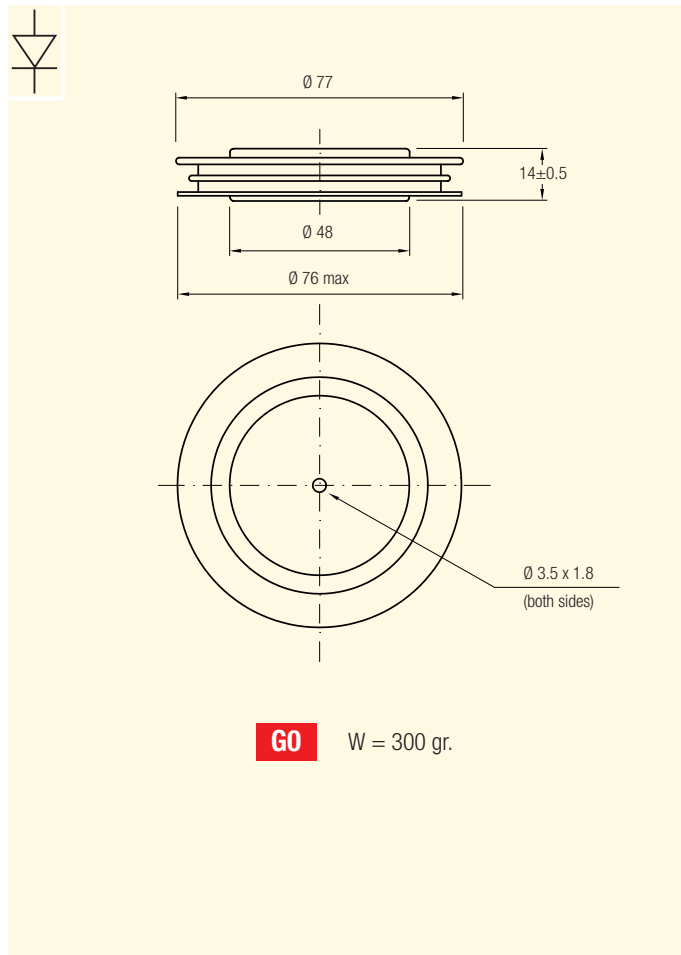
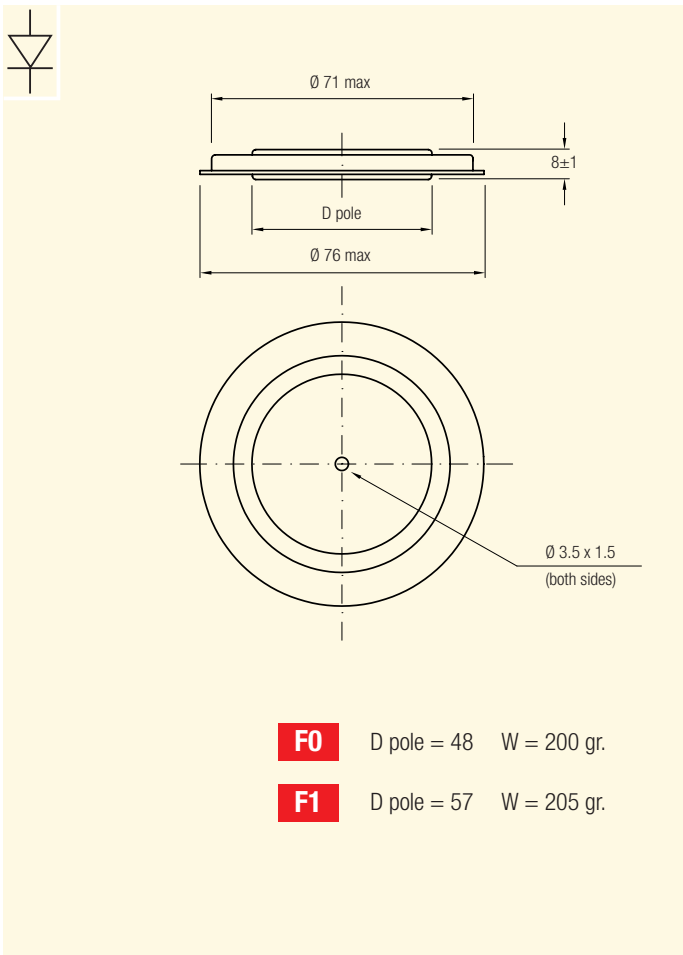
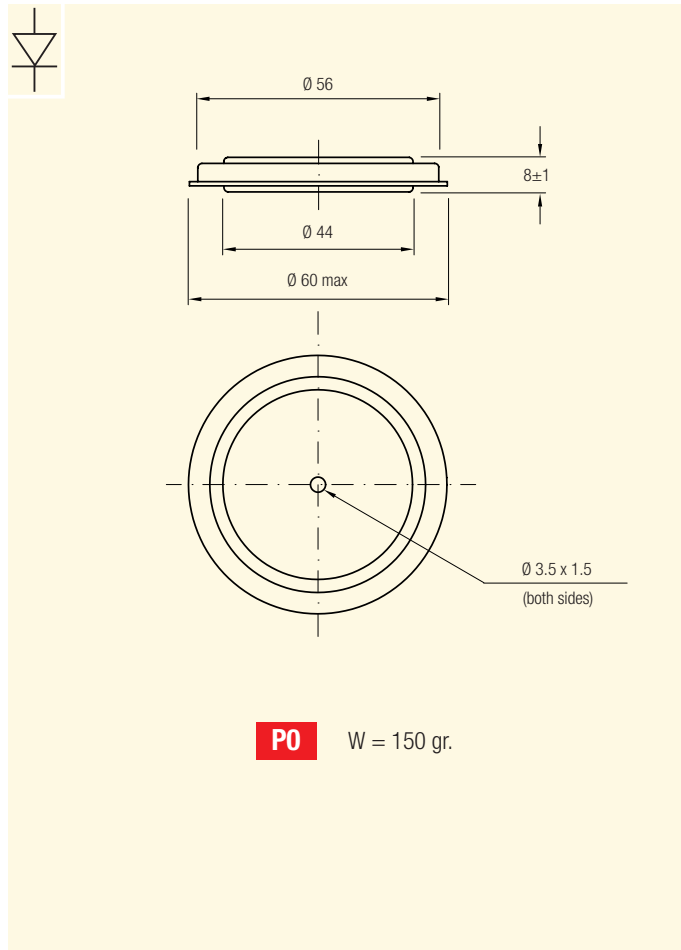
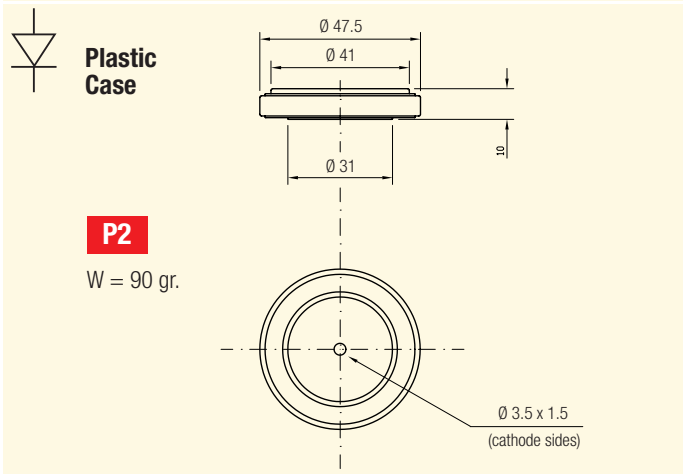
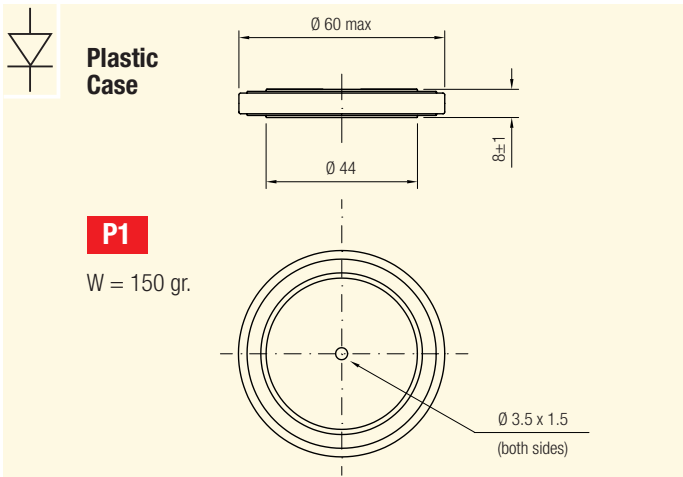

- Press-Pack High Power Semiconductors
- High Power insulated modules
- Accessories
- Heatsinks and Cooling systems
- Clamping systems
- Power assemblies
- Power converters and components for DC traction substations
- Maintenance service

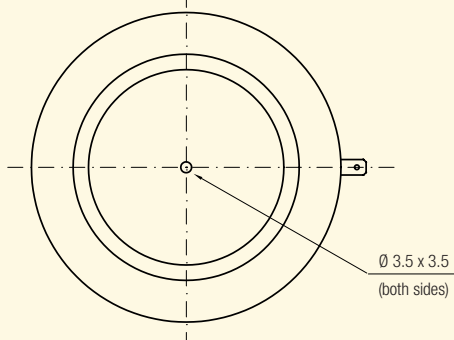
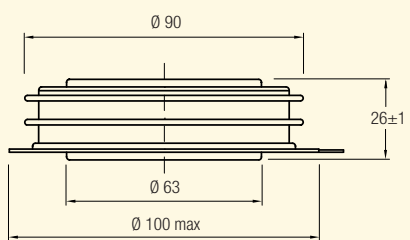

H0 W = 850 gr

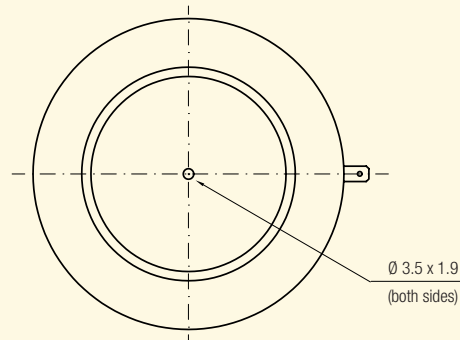
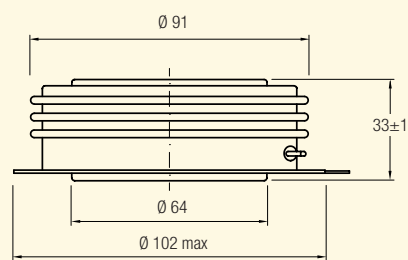

L0 W = 1000 gr

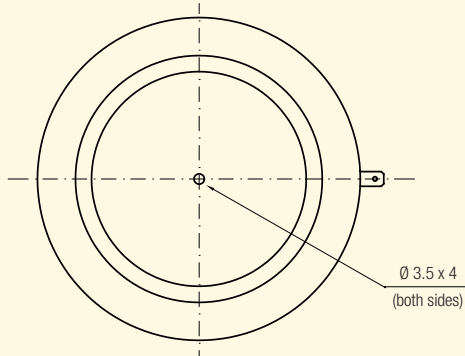
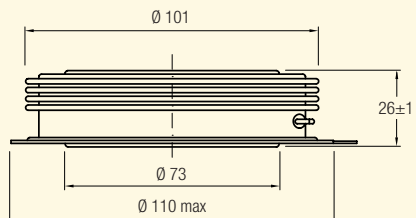
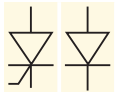

N0 W = 1150 gr

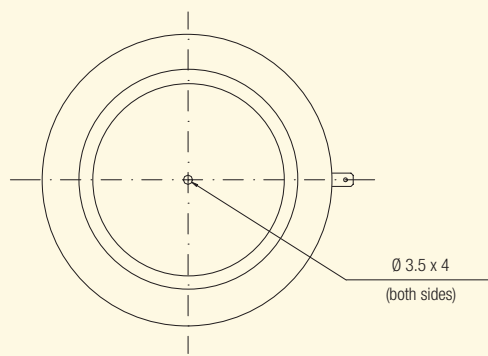
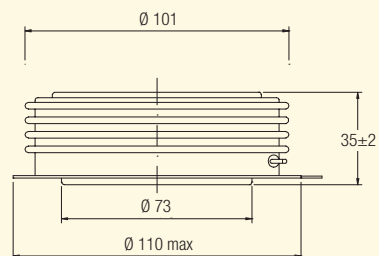
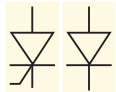

R0 W = 1500 gr

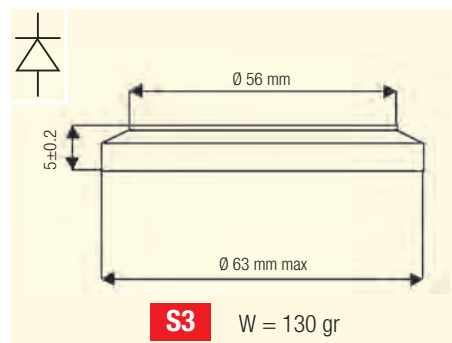
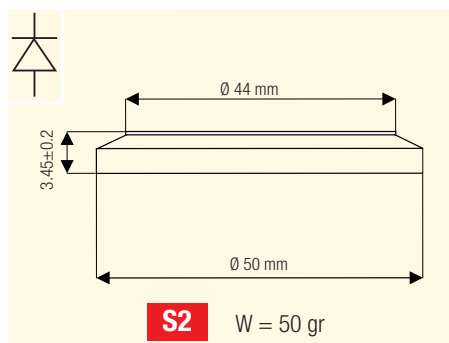
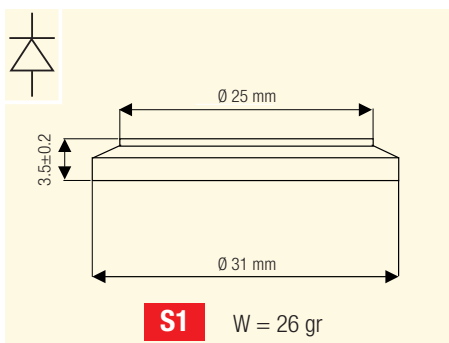
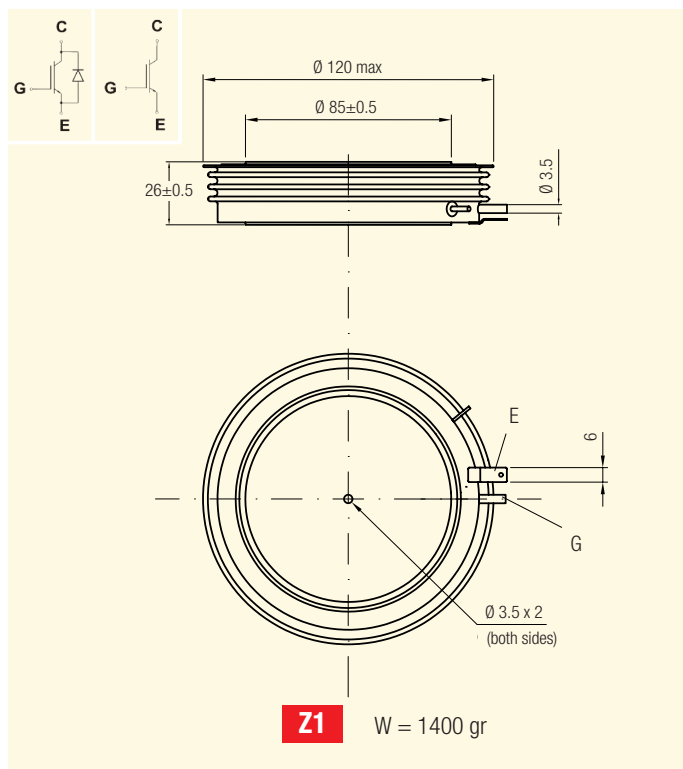
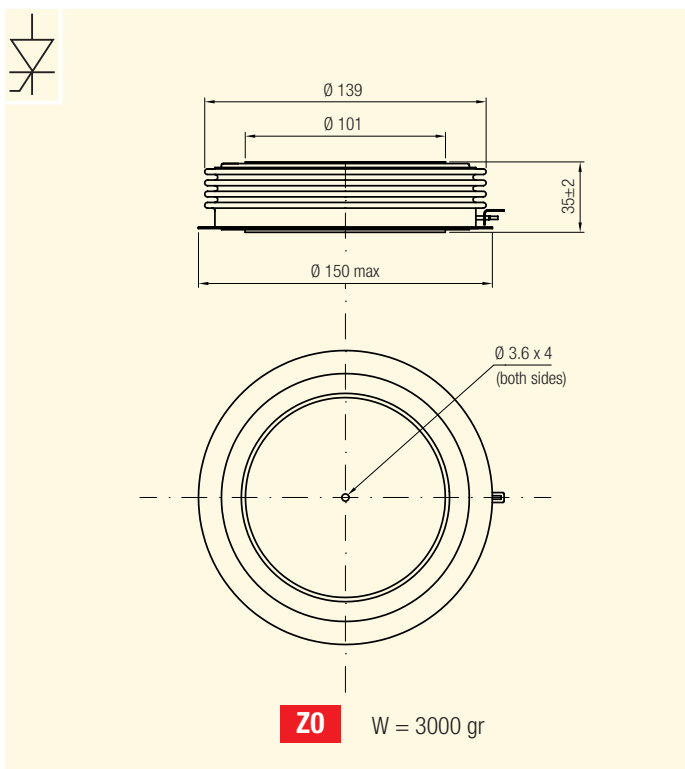
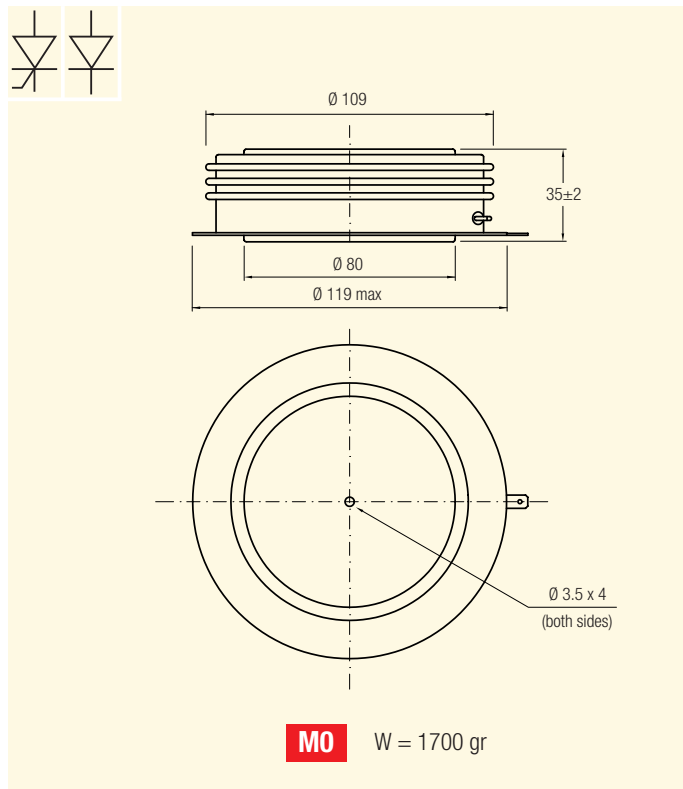
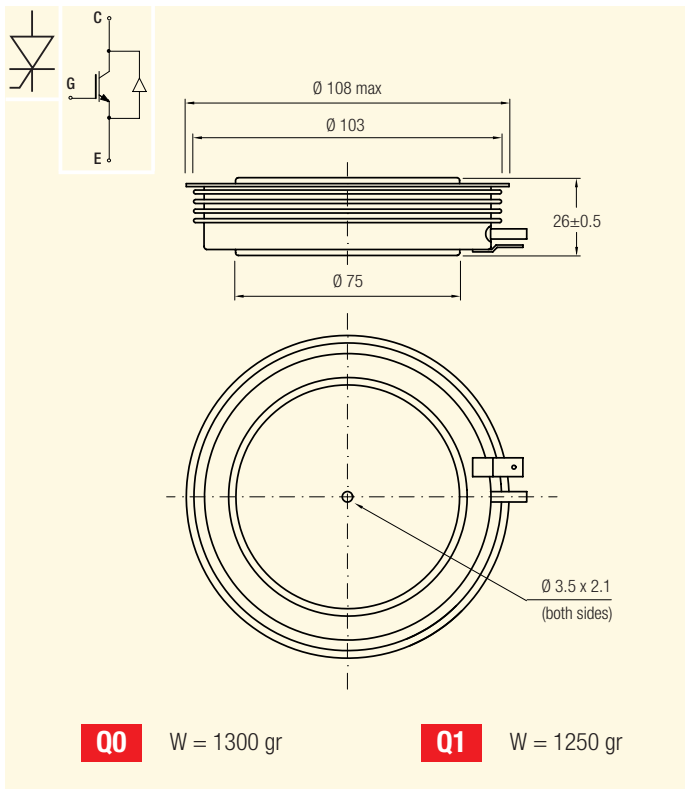

Press-Pack High Power Semiconductors

High Power insulated modules

Accessories

Heatsinks and Cooling systems

Clamping systems

Power assemblies

Power converters and components for DC traction substations

Maintenance service

Rectifier Diode and Phase Control Thyristor Insulated Modules

Main characteristics

- 6kV r.m.s. insulation voltage available on request
- Full hermetic packaging
- Base plate insulation using AlN substrate
- Industrial compatible packaging
- New G-K auxiliary output arrangement



Type	V_{DRM} V_{RRM}	$I_{FAV/Tc}$ $I_{TAV/Tc}$	I_{FSM} I_{TSM} 10 ms T_{jmax}	$V_F(T_0)$ $V_T(T_0)$ T_{jmax}	I_F I_T T_{jmax}	$R_{th(j-c)}$	T_{jmax}	Vins (RMS) 1 min $T_j=25^\circ C$	Weight	Outline	Circuit configuration
	[V]	[A]/[$^\circ C$]	[A]	[V]	[mA]	[$^\circ C/kW$]	[$^\circ C$]	[V]	[g]		
ATT501	1600	510/85	14500	1.00	0.380	50	125	4500	1500	V0	
ATT571	1600	570/91	14500	1.00	0.380	50	135	4500	1500	V0	
ATT621	1600	620/91	15000	0.90	0.340	70	135	4500	1500	V0	
ATT461	2400	460/85	12000	1.10	0.552	50	125	4500	1500	V0	
ATD501	1600	510/85	14500	1.00	0.380	50	125	4500	1500	V1	
ATD571	1600	570/91	14500	1.00	0.380	50	135	4500	1500	V1	
ATD461	2400	460/85	12000	1.10	0.552	50	125	4500	1500	V1	
ATD250HVI	4500	250/85	5900	1.35	1.335	90	125	6000	1500	V1	
ATD200HVI	5600	200/85	4500	1.45	2.850	70	125	6000	1500	V1	
ADT501	1600	510/85	14500	1.00	0.380	50	125	4500	1500	V2	
ADT571	1600	570/91	14500	1.00	0.380	50	135	4500	1500	V2	
ADT461	2400	460/85	12000	1.10	0.552	50	125	4500	1500	V2	
ADT250HVI	4500	250/85	5900	1.35	1.335	90	125	6000	1500	V2	
ADT200HVI	5600	200/85	4500	1.45	2.850	70	125	6000	1500	V2	
ADD360HVI	4500	360/85	5600	1.00	0.920	90	150	6000	1500	V3	
ADD480HVI	4500	480/85	9000	0.89	0.815	70	150	6000	1500	V3	
ADD500	3300	535/100	10300	0.89	0.675	50	150	4500	1500	V3	
ADD500HVI	3300	500/85	10300	0.89	0.675	70	150	6000	1500	V3	
ADD700	2800	725/100	17900	0.85	0.260	50	150	4500	1500	V3	
ADD700HVI	2800	700/85	17900	0.85	0.260	70	150	6000	1500	V3	
ADS1000	1000	950/100	23000	0.75	0.125	50	150	4500	1500	V4	

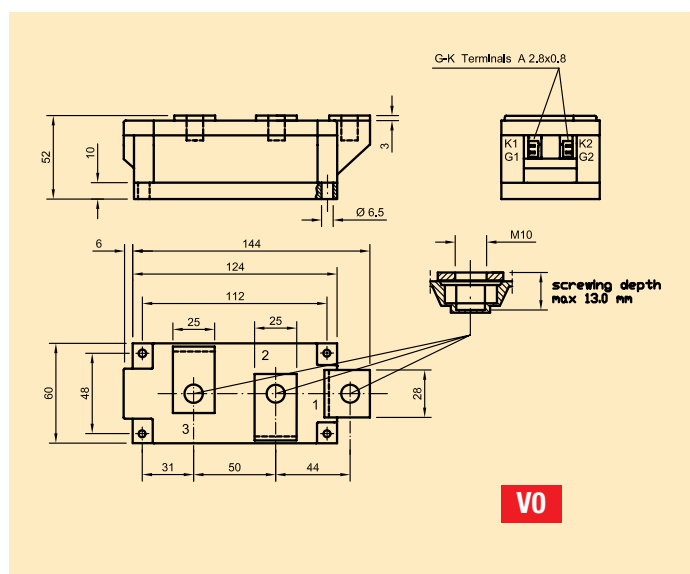

V0

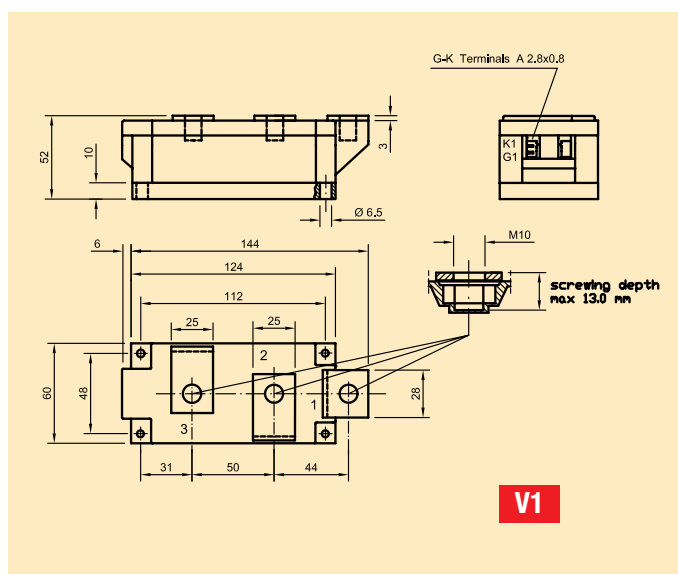

V1

Press-Pack High Power Semiconductor

High Power Insulated modules

Accessories

Heatinks and Cooling systems

Clamping systems

Power assemblies

Power converters and components for DC traction substations

Maintenance service

Main characteristics

- 6kV r.m.s. insulation voltage available on request
- Full hermetic packaging
- Base plate insulation using AlN substrate
- Industrial compatible packaging
- Contact screws available on request
- Improved recovery softness



Type	V_{DRM} V_{RRM}	I_{FAV}/T_c I_{TAV}/T_c	I_{FSM} I_{TSM} 10 ms T_{jmax}	$V_F(T_0)$ $V_T(T_0)$ T_{jmax}	I_F I_T T_{jmax}	Q_{rr}^*	$R_{th(j-c)}$	T_{jmax}	Vins (RMS) 1 min $T_j=25^\circ C$	Weight	Outline	Circuit configuration
	[V]	[A]/[$^\circ C$]	[A]	[V]	[mA]	[μC]	[$^\circ C/kW$]	[$^\circ C$]	[V]	[g]		
AFF230	2600	236/100	5000	1.15	1.500	185	125	150	4500	1500	V3	
AFF300	2600	300/70	5000	1.15	0.685	120	105	125	4500	1500	V3	
AFF150	3300	150/70	2500	1.86	4.300	55	105	125	4500	1500	V3	
AFF350	4500	350/55	9000	2.70	1.400	500	50	125	4500	1500	V3	
AFF450	4500	450/100	10000	1.40	0.75	1600	50	150	4500	1500	V3	
AFF450HVI	4500	450/80	10000	1.40	0.75	1600	50	150	6000	1500	V3	
AFF230A	2600	236/100	5000	1.15	1.500	185	125	150	4500	1500	V3	
AFF300A	2600	300/70	5000	1.15	0.685	120	105	125	4500	1500	V3	
AFF150A	3300	150/70	2500	1.86	4.300	55	105	125	4500	1500	V3	
AFF350A	4500	350/55	9000	2.70	1.400	500	50	125	4500	1500	V3	
AFF450A	4500	450/100	10000	1.40	0.75	1600	50	150	4500	1500	V3	
AFF450AHVI	4500	450/80	10000	1.40	0.75	1600	50	150	6000	1500	V3	
AFF230K	2600	236/100	5000	1.15	1.500	185	125	150	4500	1500	V3	
AFF300K	2600	300/70	5000	1.15	0.685	120	105	125	4500	1500	V3	
AFF150K	3300	150/70	2500	1.86	4.300	55	105	125	4500	1500	V3	
AFF350K	4500	350/55	9000	2.70	1.400	500	50	125	4500	1500	V3	
AFF450K	4500	450/100	10000	1.40	0.75	1600	50	150	4500	1500	V3	
AFF450KHVI	4500	450/80	10000	1.40	0.75	1600	50	150	6000	1500	V3	

* Recovery conditions: $I_F = 200 A$; $di/dt = 100 A/\mu s$; $V_R = 50 V$

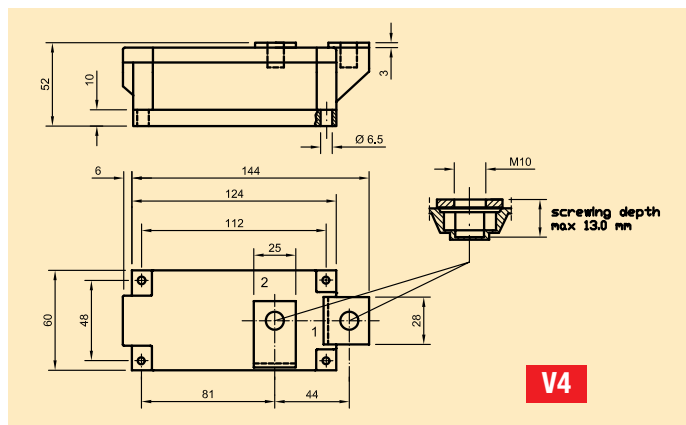
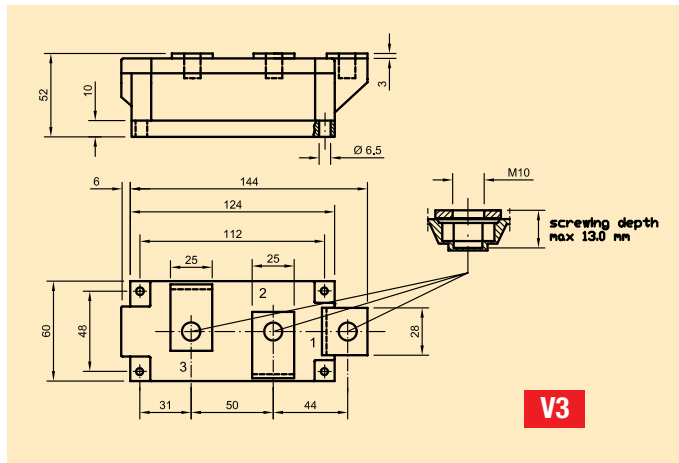
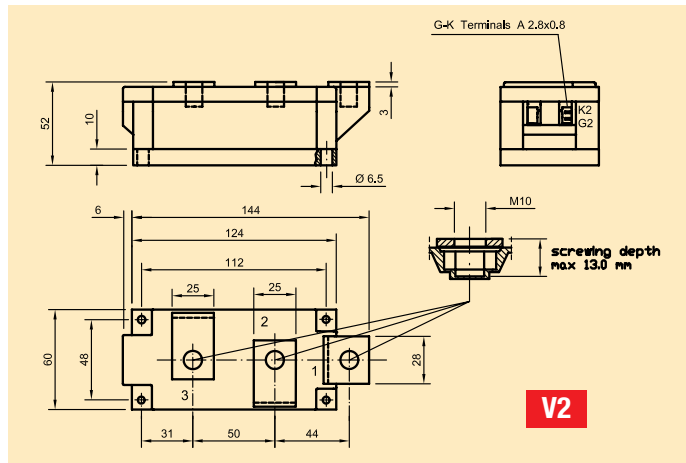

Press-Pack High Power Semiconductor

High Power insulated modules

Accessories

Heatinks and Cooling systems

Clamping systems

Power assemblies

Power converters and components for DC traction substations

Maintenance service

High Current Rectifier Diode and Phase Control Thyristors Insulated Modules

Main characteristics

- 8kV r.m.s. insulation voltage available on request
- Full hermetic packaging
- Base plate insulation using AlN substrate
- Industrial compatible packaging
- Contract screws available on request



Type	V_{DRM} V_{RRM}	$I_{FAV/Tc}$ $I_{TAV/Tc}$	I_{FSM} I_{TSM} 10 ms T_{Jmax}	$V_F(T_0)$ $V_T(T_0)$ T_{Jmax}	I_F I_T T_{Jmax}	$R_{th(j-c)}$	T_{Jmax}	Vins (RMS) 1 min $T_J=25^\circ C$	Weight	Outline	Circuit configuration
	[V]	[A]/[$^\circ C$]	[A]	[V]	[mA]	[$^\circ C/kW$]	[$^\circ C$]	[V]	[g]		
AZT1150	800	1150/85	30	0.80	0.120	42	140	4500	2800	V5	
AZT800	1800	800/85	30	0.82	0.180	42	125	4500	2800	V5	
AZT740	2200	740/85	30	0.90	0.240	42	125	4500	2800	V5	
AZT630	2800	630/85	26	1.05	0.290	42	125	4500	2800	V5	
AZT530	3600	530/85	17	1.20	0.450	42	125	4500	2800	V5	
AZT460	4500	460/85	11	1.20	0.700	42	125	4500	2800	V5	
AZT400HVI	4500	400/85	11	1.20	0.700	51	125	6000	2800	V5	
AZT310HVI	5600	310/85	10	1.30	1.150	51	120	6000	2800	V5	
AZD1600	1000	1600/95	45	0.75	0.055	57	160	4500	2800	V6	
AZD1280	1000	1280/100	38	0.75	0.055	42	150	4500	2800	V6	
AZD1080	2800	1080/100	30	0.80	0.110	42	150	4500	2800	V6	
AZD930	4500	930/100	19	0.80	0.210	42	150	4500	2800	V6	
AZD780HVI	4500	780/100	19	0.80	0.210	51	150	6000	2800	V6	
AZD610HVI	5600	610/100	20	1.00	0.400	51	150	6000	2800	V6	

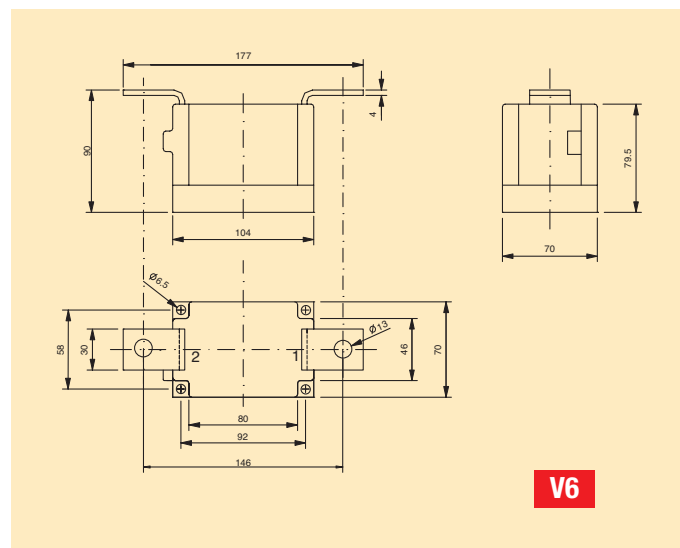
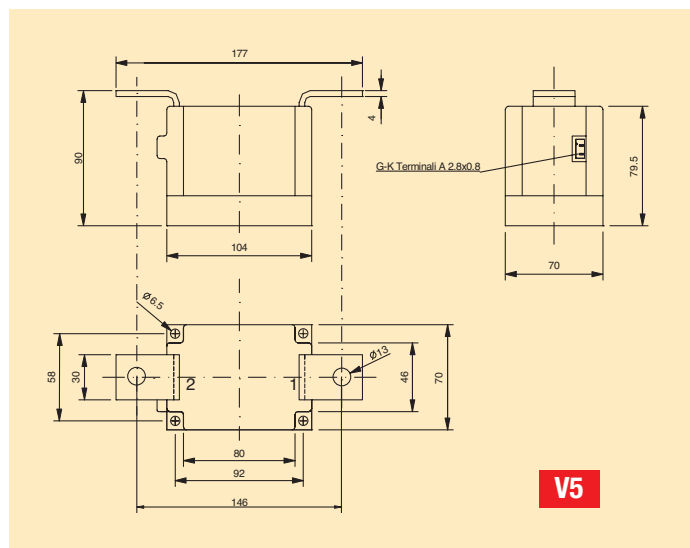

Press-Pack High Power Semiconductor

High Power Insulated modules

Accessories

Heatinks and Cooling systems

Clamping systems

Power assemblies

Power converters and components for DC traction substations

Maintenance service

Main characteristics

- Insulation Voltage up to 9.5 kV r.m.s.
- Custom design to optimize circuit applications
- Possibility of to realize power insulate module with full compatibility with obsolete devices.
- The material used are conform to UL94 VO standard and ROHS requirement.



Power Module type APM		1st device data					2nd device data					T _{J max}	V _{ins}	Outline
		V _{DRM}	V _{RRM}	I _{T (AV)}	I _{TSM}	I ² t A ² s ² 10 ³	V _{DRM}	V _{RRM}	I _{T (AV)}	I _{TSM}	I ² t A ² s ² 10 ³			
		[V]	[V]	[A]	[kA]		[V]	[V]	[A]	[kA]		[°C]	[V]	
APM2000GF	GTO / Diode	2500	16	435	11	605	-	2500	400	11	605	125	3500	K2
APM2000GFF	GTO / Diode	2500	16	435	11	605	-	2500	400	11	605	125	3500	K3
APM310TDHVI	Thyristor / Diode	5600	5600	310	10	500	-	5600	738	20	2000	120	6000	K1
APM319TTHVI	Thyristor pair	5600	5600	310	10	500	5600	5600	310	10	500	120	6000	K1
APM740DDHVI	Diode pair	-	5600	738	20	2000	-	5600	738	20	2000	150	6000	K1

K1



K2

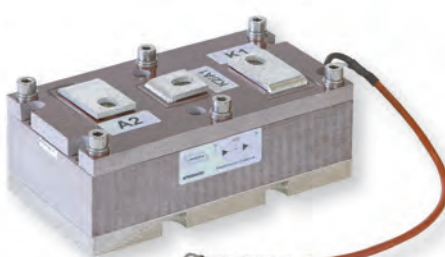

K3



Insulate Power Module type ABI		V _{RRM}	V _{ins} rms	Outline
		Diode		
		[V]	[V]	
ABI-1-ARF261S33	1 fast recovery diode	3300	6000	Y1
ABI-2-ARF261S33KK	2 fast recovery diodes	3300	6000	Y2
ABI-2-ARF261S33AA	2 fast recovery diodes	3300	6000	Y3

Insulate Power Module type ABI High insulation types		V _{RRM}	V _{ins} rms
		Diode	
		[V]	[V]
ABI-1-ARF261HVIS33	1 fast recovery diode	3300	9500
ABI-1-ARF261HVIS33	2 fast recovery diodes	3300	9500
ABI-1-ARF261HVIS33	2 fast recovery diodes	3300	9500

Y1



Y2



Y3



Press-Pack High Power Semiconductor

High Power insulated modules

Accessories

Heatsinks and Cooling systems

Clamping systems

Power assemblies

Power converters and components for DC traction substations

Maintenance service

Gate lead for Press-Pack Devices

Main characteristics

Custom special gate lead are available on request
All products are manufactured using material conform to UL94-V0

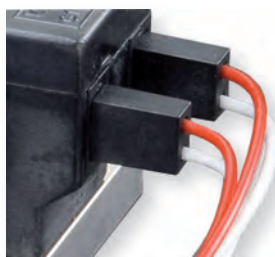

Type	Application	Lead type	Color		Length rms	Conductor construction	Insulating material	Operating temperature	Outline
			K	G					
					L/L1 [mm]			[°C]	
AGL250	thyristors	bipolar	red	white	305	19x0,203mm	FEP	-55÷125	Y1
AGL255	thyristors	twisted bipolar	red	white	305	19x0,203mm	FEP	-55÷125	Y2
AGL260	thyristors	bipolar	red	white	500	19x0,16mm	FEP	-55÷135	Y1
AGL275	thyristors	twisted bipolar	red	white	620	19x0,203mm	FEP	-55÷125	Y2
AGL276	thyristors	twisted bipolar	red	white	1020	19x0,203mm	FEP	-55÷125	Y2
AGL277	thyristors	twisted bipolar	red	white	1520	19x0,203mm	FEP	-55÷125	Y2
AGL251	modules	bipolar	red	white	305	19x0,203mm	FEP	-55÷125	Y4
AGL300	asymm. thyristors	coaxial	black	white	1000	19x0,203mm	FEP	-55÷105	Y3
AGL791	GTO	coaxial	black	white	400	3,5mmq	ETFE	-55÷105	Y5
AGL795	GTO	bipolar	black	white	103/86	3,5mmq	FEP	-55÷125	Y7
AGL796	GTO	twisted bipolar	black	white	150	3,5mmq	FEP	-55÷105	Y6

Y1

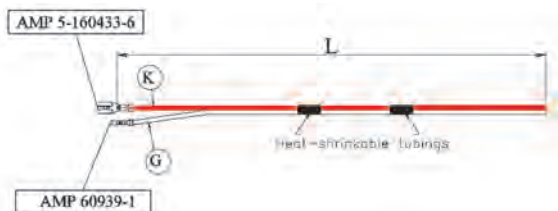

Y2



Y3

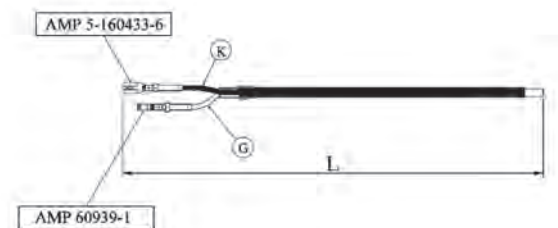

Y4

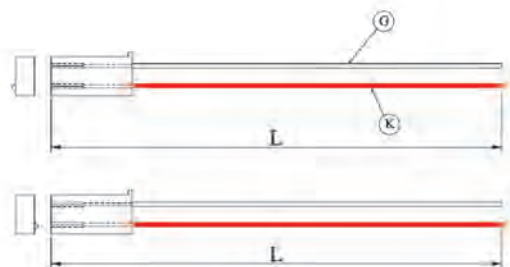

Y5

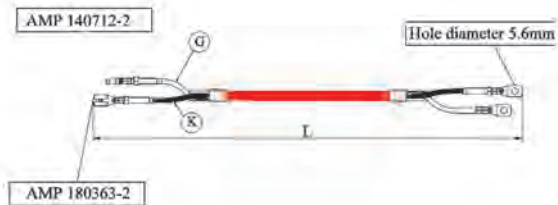

Y6

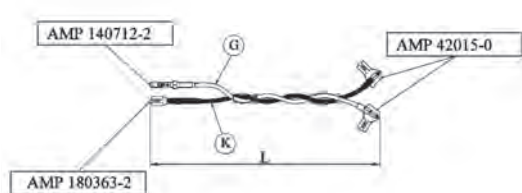

Y7

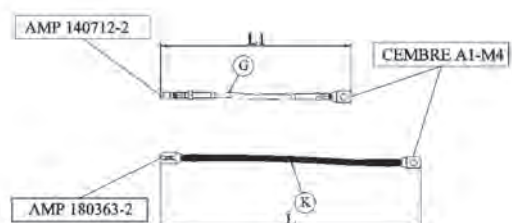

Main characteristics

Custom design gate boards optimized for specific application are available on request.

A large quantities of different snubber circuits can be supplied in order to optimized the devices performance.

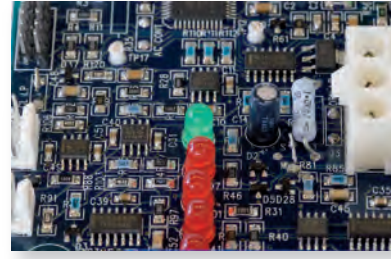

Type	Description	Outline
ASE010	Thyristor gate driver board	GB1
ASE004	Thyristors gate driver board for short circuit device	GB2
ASE040	Multi- thyristors gate driver	GB3
ASE020	GTO Gate driver board	GB4
ASE030	IGBT module gate driver board	GB5
ASE005	Snubber circuit for rectifier diode bridge arms	SN1

GB1

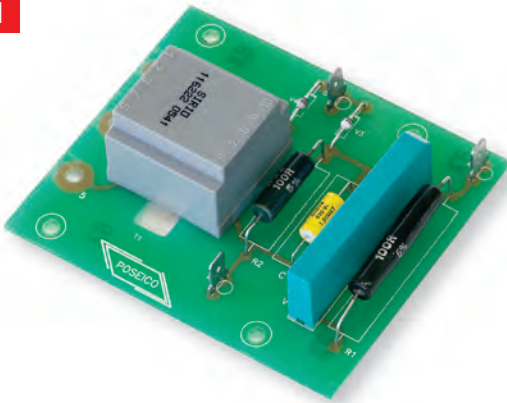

GB2

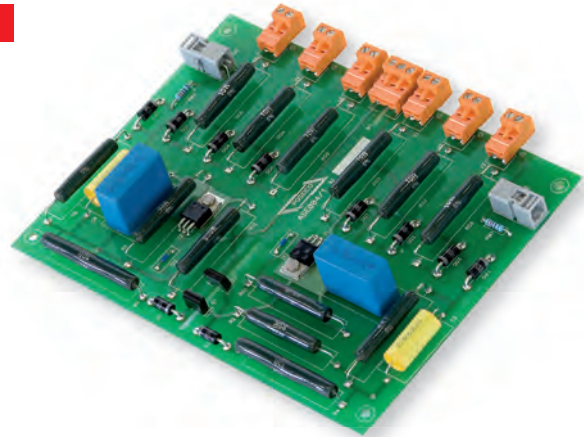

GB3



GB4

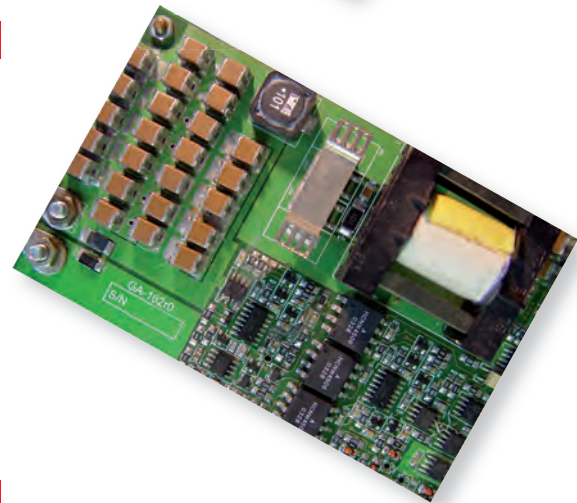

GB5

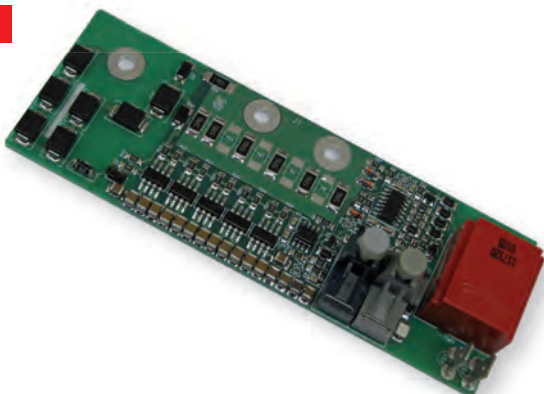

SN1

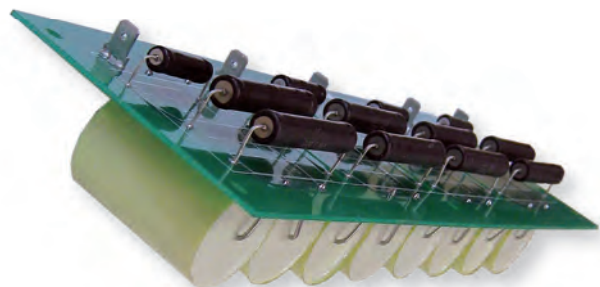

Press-Pack High Power Semiconductor

High Power insulated modules

Accessories

Heatinks and Cooling systems

Clamping systems

Power assemblies

Power converters and components for DC traction substations

Maintenance service

Water Cooling Heatsinks

Main characteristics

High temperature brazed aluminium.
 Internal surfaces are maintained clean and suitable for deionized water cooling.
 Design assisted by FEM simulation to optimize thermal efficiency and uniformity.
 Fully tested by POSEICO using special dedicated equipments.
 Custom connections available on request.

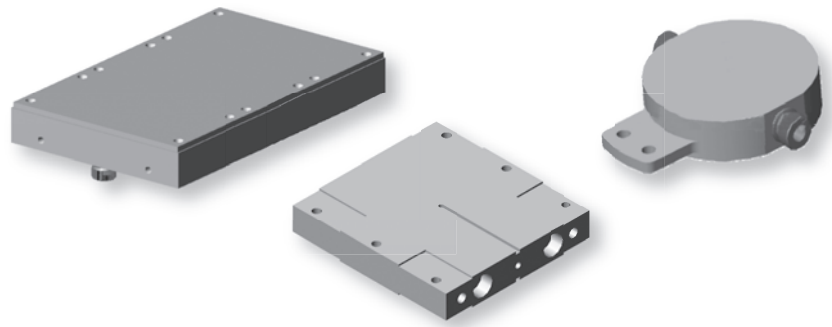

Type	Q range minimum medium	R _{th} at Q		ΔPmax at Q		Weight [g]	Standard Nipple	Outline
		[l/m]	[°C/kW]	[l/m]	[mbar]			
AWCH-PPC-D60H22	3/9	10,5*	6,0	200	6,0	160	Z1	A
AWCH-PPC-D60H28T	3/9	10,5*	6,0	500	6,0	160	Z1	B
AWCH-PPC-D90H22	3/9	5,5*	6,0	300	6,0	330	Z1	C
AWCH-PPC-D90H22C	3/9	6,0*	6,0	300	6,0	330	Z1	D
AWCH-PPC-D90H28T	3/9	7,0*	6,0	500	6,0	330	Z1	E
AWCH-L192W140T28	3/9	5,5	6,0	300	6,0	2100	Z2	F
AWCH-L192W140T28X	3/9	3,5	6,0	670	6,0	2100	Z2	F
AWCH-L228W140T28	3/9	5,0	6,0	200	6,0	1800	Z2	G
AWCH-L228W140T28X	3/9	3,0	6,0	600	6,0	1800	Z2	G
AWCH-L137W146T25X	2/10	5,0*	5,0	250	5,0	1800	Z3	H
AWCH-L125W125T20X	2/8	5,6*	5,0	500	5,0	850	Z3	I

R_{th} values for double side employ.

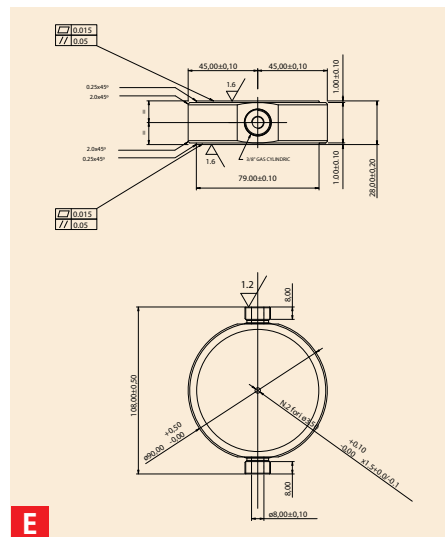
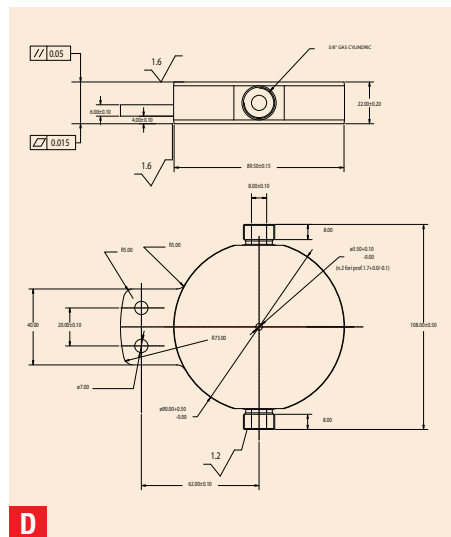
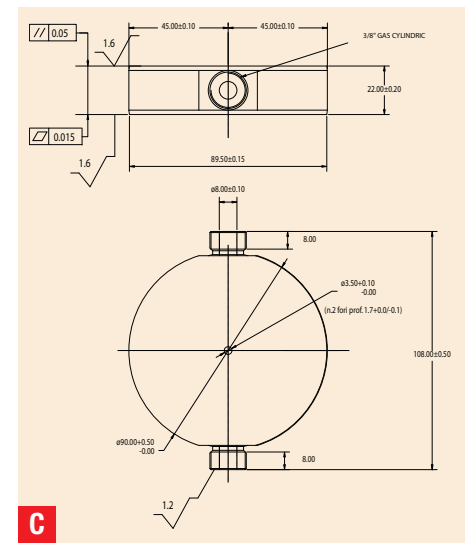
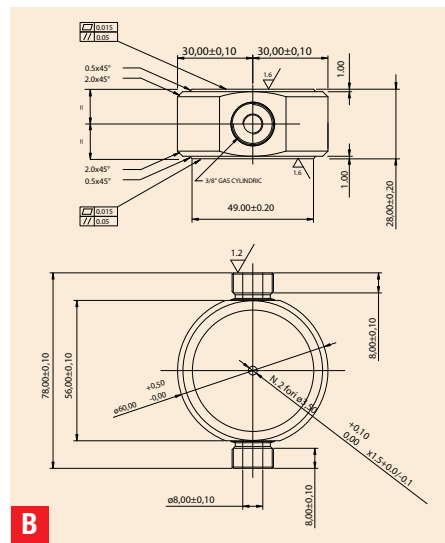
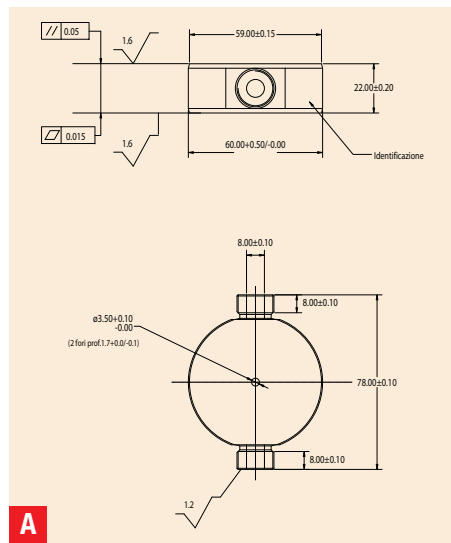

Press-Pack High Power Semiconductor
 High Power Insulated modules
 Accessories
 Heatsinks and Cooling systems
 Clamping systems
 Power assemblies
 Power converters and components for DC traction substations
 Maintenance service

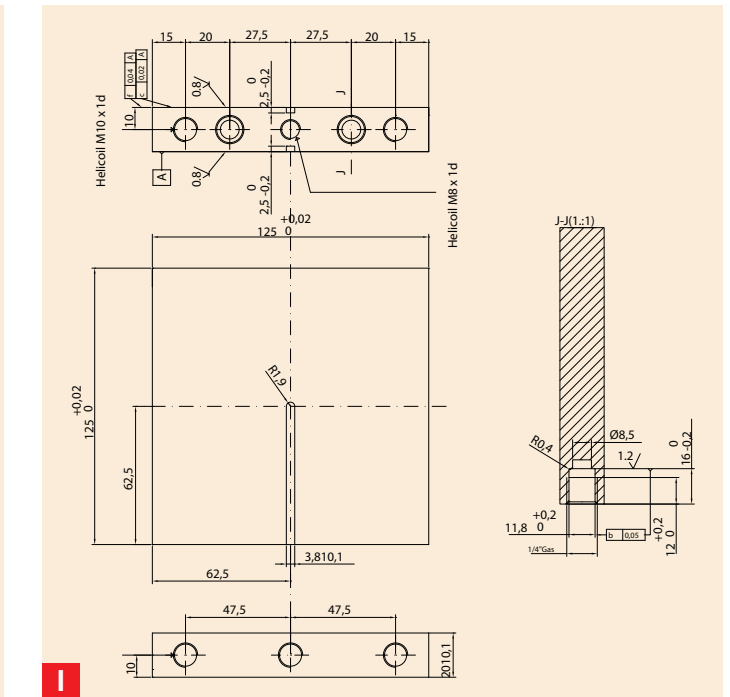
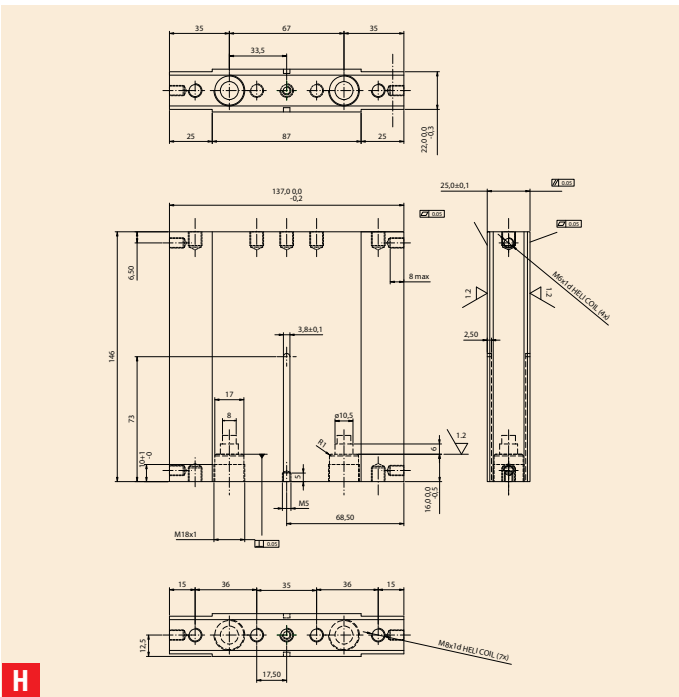
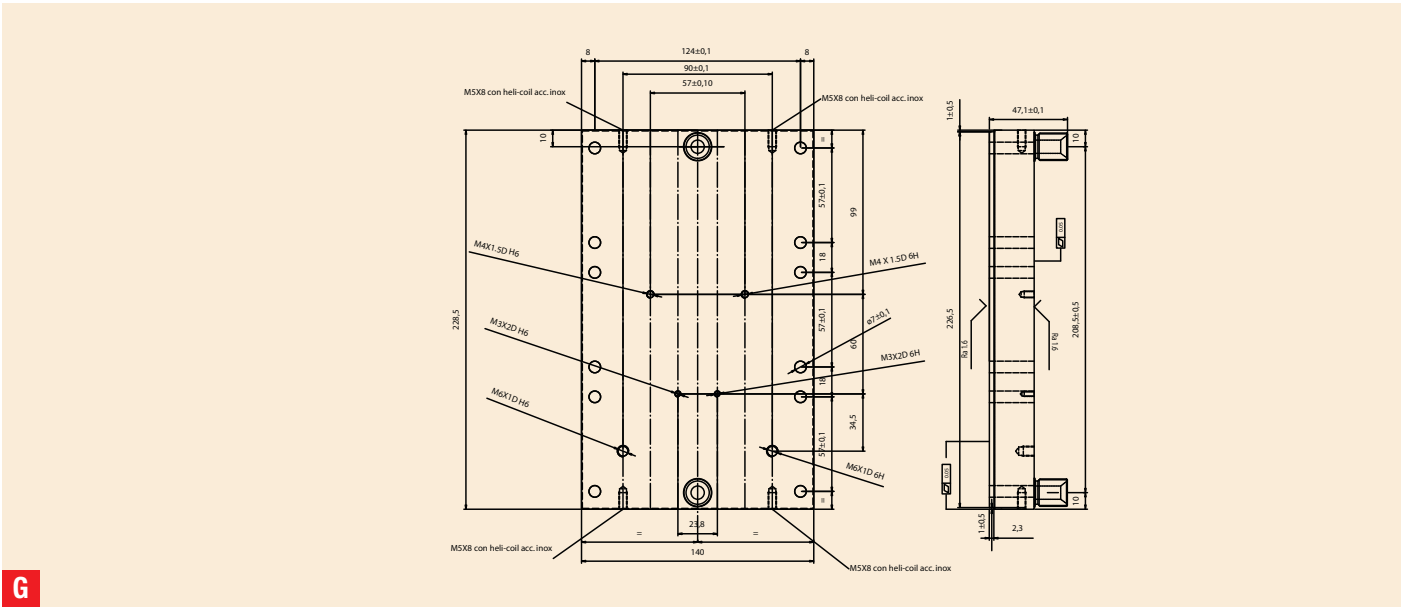
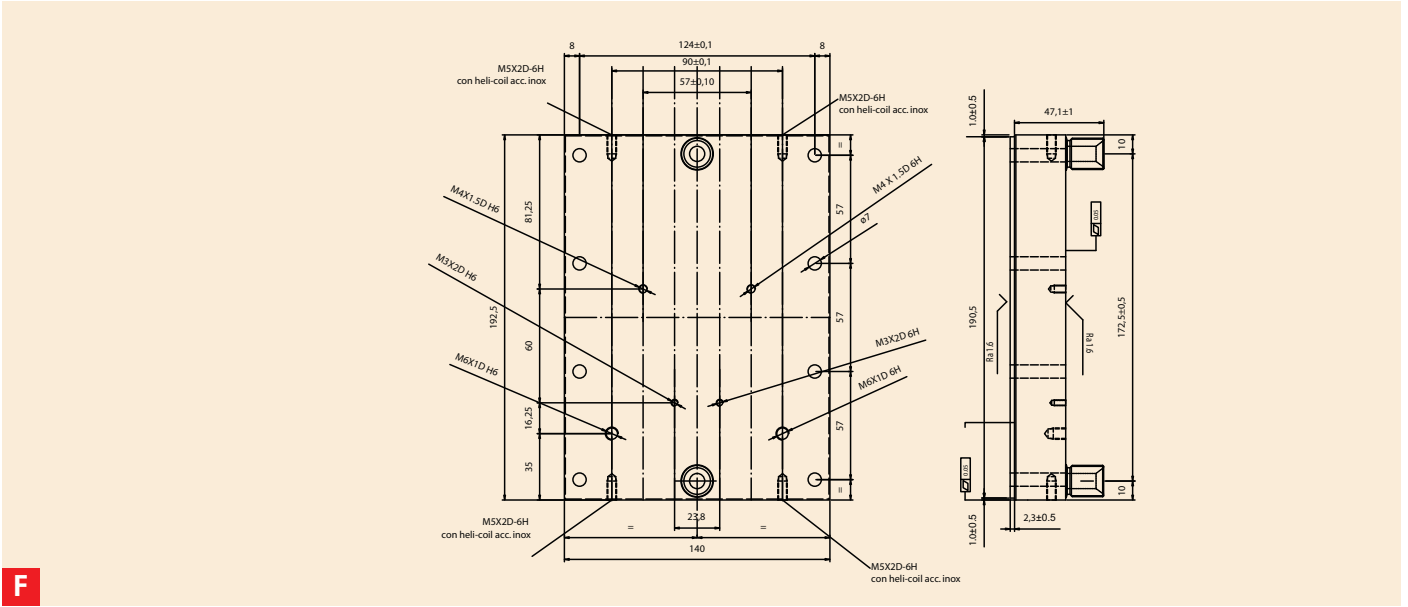

Press-Pack High Power Semiconductor

High Power insulated modules

Accessories

Heatsinks and Cooling systems

Clamping systems

Power assemblies

Power converters and components for DC traction substations

Maintenance service

Forced Air Copper Heatsinks

Main characteristics

High performance heatsinks for air forced cooling

1 mm Copper fins soft soldered to Copper pole

Customized design on request

Nichel plated surface treatment

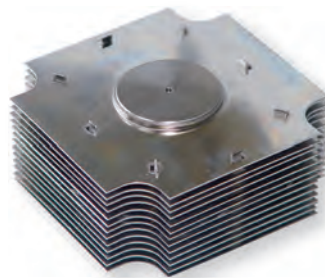

Type	D	Number of fins	H	L	W	Number of signals connection	A	B	DH holes diameter	R _{th} Thermal resistance (1)	P Weight	Layout
	Core diameter		Core thickness	Dimensions of fins			Distance between hole					
	[mm]		[mm]	[mm]	[mm]		[mm]	[mm]	[mm]	[°C/W]	[kg]	
F45L102W127S02	45	2	9	102	127	2	66	46	11	0,60	0,37	CH1
F45L102W127S03	45	3	13,5	102	127	2	66	46	11	0,44	0,56	CH1
F45L102W127S05	45	5	22,2	102	127	2	66	46	11	0,30	0,93	CH1
F45L102W127S06	45	6	27	102	127	2	66	46	11	0,26	1,12	CH1
F45L102W127S09	45	9	40,5	102	127	2	66	46	11	0,19	1,67	CH1
F45L102W127S12	45	12	54	102	127	2	66	46	11	0,15	2,23	CH1
F50L102W127S02	50	2	9	102	127	2	44	84	13	0,60	0,39	CH1
F50L102W127S03	50	3	13,5	102	127	2	44	84	13	0,44	0,59	CH1
F50L102W127S04	50	4	18	102	127	2	44	84	13	0,35	0,78	CH1
F50L102W127S05	50	5	22,2	102	127	2	44	84	13	0,30	0,97	CH1
F50L102W127S06	50	6	27	102	127	2	44	84	13	0,26	1,17	CH1
F50L102W127S07	50	7	31,5	102	127	2	44	84	13	0,23	1,37	CH1
F50L102W127S08	50	8	36	102	127	2	44	84	13	0,21	1,57	CH1
F50L102W127S09	50	9	40,5	102	127	2	44	84	13	0,19	1,76	CH1
F50L102W127S10	50	10	45	102	127	2	44	84	13	0,17	1,96	CH1
F50L102W127S11	50	11	49,5	102	127	2	44	84	13	0,16	2,15	CH1
F50L102W127S12	50	12	54	102	127	2	44	84	13	0,15	2,35	CH1
F50L127W170S12	50	2	9	127	170	2	44	84	17	0,32	0,57	CH2
F65L127W170S02	65	2	9	127	170	2	110	45	17	0,32	0,65	CH2
F65L127W170S03	65	3	13,5	127	170	2	110	45	17	0,25	0,98	CH2
F65L127W170S04	65	4	18	127	170	2	110	45	17	0,22	1,30	CH2
F65L127W170S05	65	5	22,5	127	170	2	110	45	17	0,19	1,63	CH2
F65L127W170S06	65	6	27	127	170	2	110	45	17	0,17	1,96	CH2
F65L127W170S07	65	7	31,5	127	170	2	110	45	17	0,16	2,28	CH2
F65L127W170S08	65	8	36	127	170	2	110	45	17	0,15	2,61	CH2
F65L127W170S09	65	9	40,5	127	170	2	110	45	17	0,14	2,94	CH2
F65L127W170S10	65	10	45	127	170	2	110	45	17	0,13	3,26	CH2
F65L127W170S11	65	11	49,5	127	170	2	110	45	17	0,12	3,59	CH2
F65L127W170S12	65	12	54	127	170	2	110	45	17	0,12	3,91	CH2
F65L127W170S12A	65	12	54	127	170	0	110	45	17	0,12	3,91	CH2
F65L127W170S03L	65	3	13,5	127	170	2	110	86	17	0,25	0,98	CH2
F65L127W170S06L	65	6	27	127	170	2	110	86	17	0,17	1,96	CH2
F65L127W170S09L	65	9	40,5	127	170	2	110	86	17	0,14	2,94	CH2
F65L127W170S12L	65	12	54	127	170	2	110	86	17	0,12	3,91	CH2
F50L125W125S13	50	13	53	125	125	0	-	-		0,11	2,37	CH3
F65L127W127S06	65	6	27	127	127	2	86	86			1,43	CH4
F65L127W127S12	65	12	54	127	127	2	86	86		0,18	2,86	CH4

(1) Thermal resistance with air flow 3 m/s.

Press-Pack High Power Semiconductor

High Power Insulated modules

Accessories

Heatsinks and Cooling systems

Clamping systems

Power assemblies

Power converters and components for DC traction substations

Maintenance service

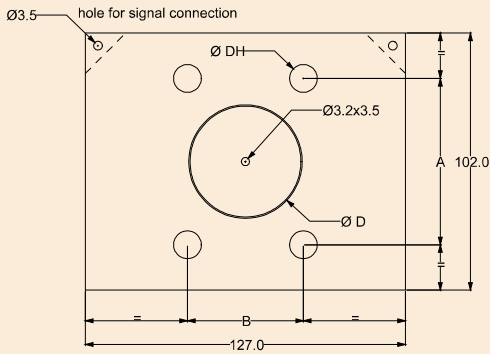
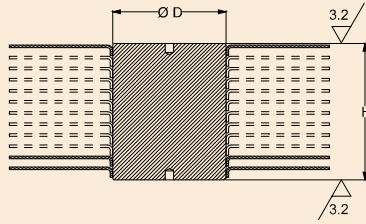

CH1

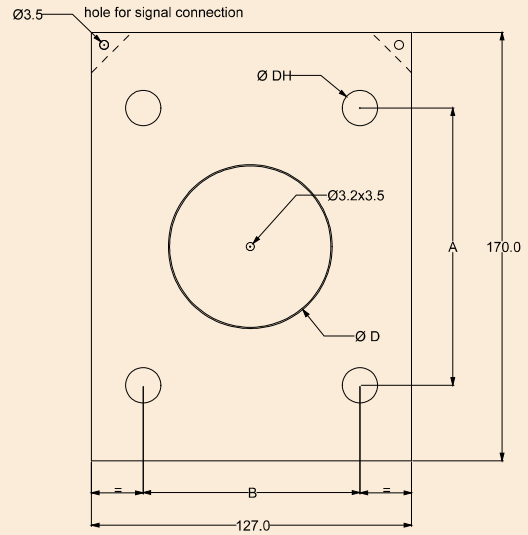
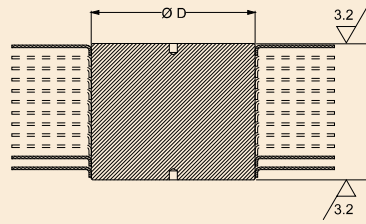

CH2

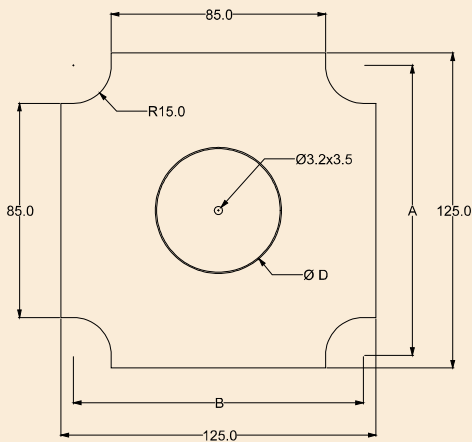
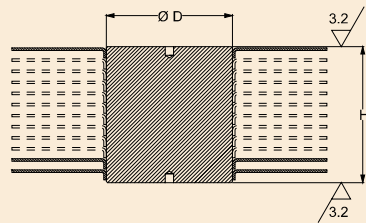

CH3

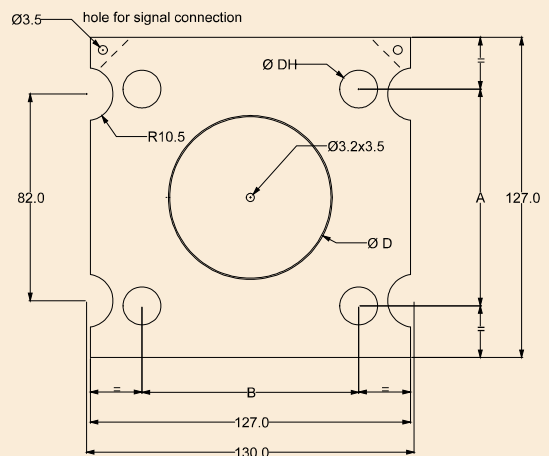
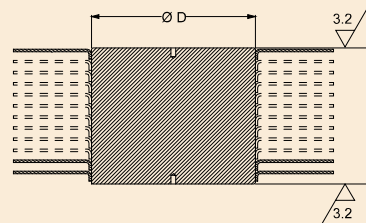

CH4

Press-Pack High Power Semiconductor

High Power insulated modules

Accessories

Heatsinks and Cooling systems

Clamping systems

Power assemblies

Power converters and components for DC traction substations

Maintenance service

Natural Air Heatsinks

Main characteristics

- Extruded aluminium heatsink type EN AW 6063 T6
- Finishing with silver or black anodization on request
- Customized design
- High quality level of contact surface

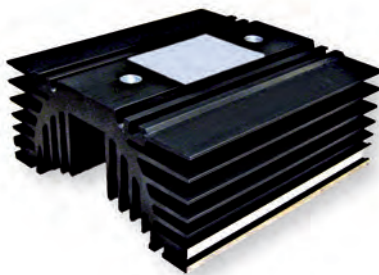

Heatsink Code	POSEICO extruded reference	Length	Distance between holes center	Number of elements (type of configuration)	Thermal resistance for bilateral cooling (2 elements)	Standard finishing	Shape (see drawings)
		L	l		$R_{th} (Pd)$		
		[mm]	[mm]		[K/C]		
A14N152P70-2	N6	152	70	2 (B)	0,25 @ 150 W	normal	A14
A14N228P70-2	N6	228	70	2 (B)	0,18 @ 150 W	normal	A14
A10N300P70-2	N8	300	70	2 (B)	0,12 @ 150 W	normal	A10
A10N300P89-2	N8	300	89	2 (B)	0,12 @ 150 W	normal	A10
A22N300P70-2	W180	300	70	2 (B)	0,12 @ 400 W	normal	A22
A22N300P89-2	W180	300	89	2 (B)	0,12 @ 400 W	normal	A22
A12N250P89-2B	N9	250	89	2 (B)	0,11 @ 500 W	black	A12
A12N250P155-2B	N9	250	155	2 (B)	0,11 @ 500 W	black	A12
A12N300P89-2B	N9	300	89	2 (B)	0,09 @ 500 W	black	A12
A12N300P155-2B	N9	300	155	2 (B)	0,09 @ 500 W	black	A12
A12N900P89-4B	N9	900	89	4 (C)	see data sheet	black	A12
A12N900P155-4B	N9	900	155	4 (C)	see data sheet	black	A12

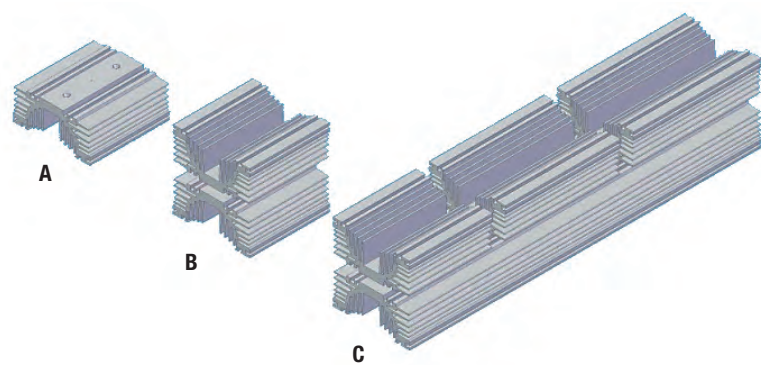

Type of configuration

- A = 1 element
- B = 2 element
- C = 4 element

Ordering informations:

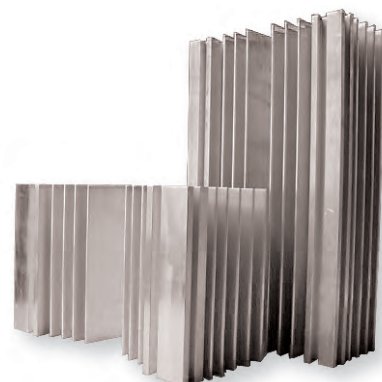
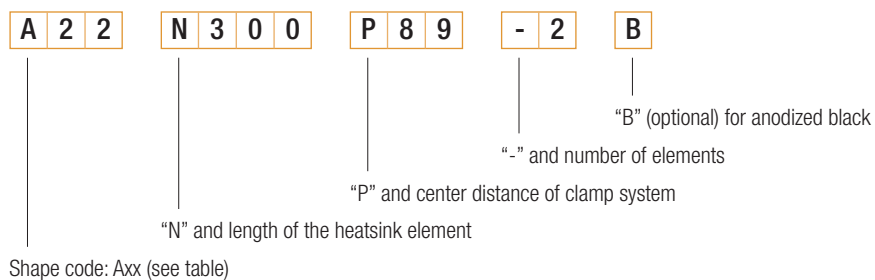

Press-Pack High Power Semiconductor

High Power Insulated modules

Accessories

Heatsinks and Cooling systems

Clamping systems

Power assemblies

Power converters and components for DC traction substations

Maintenance service

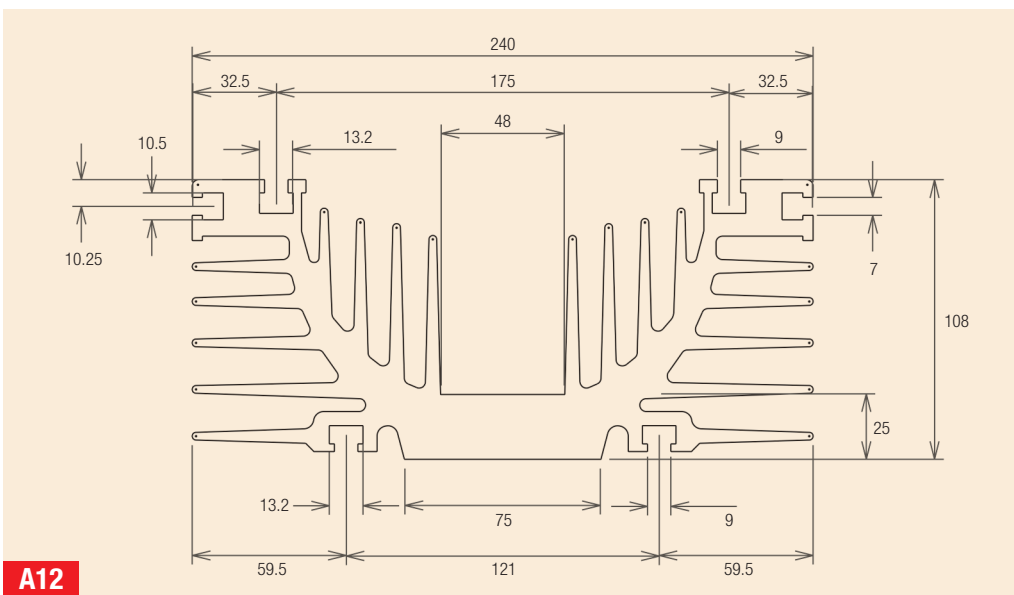
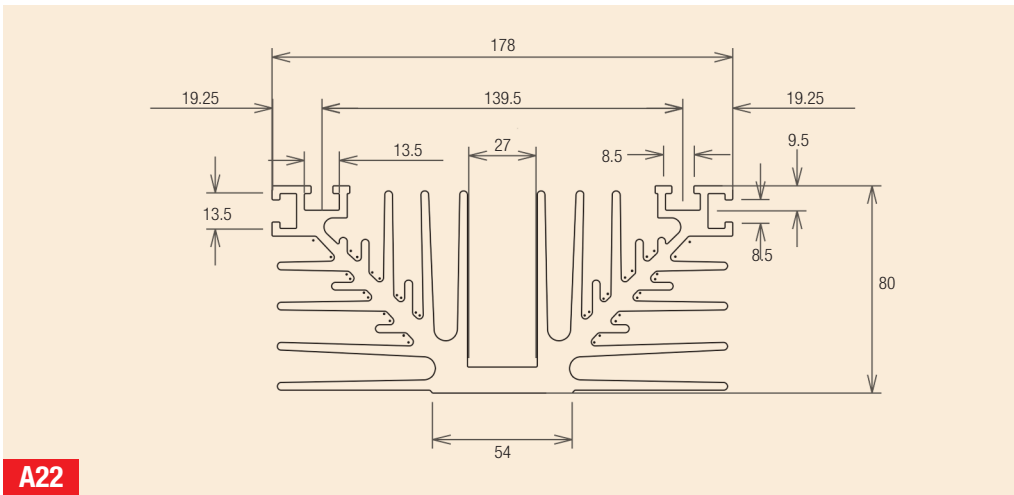
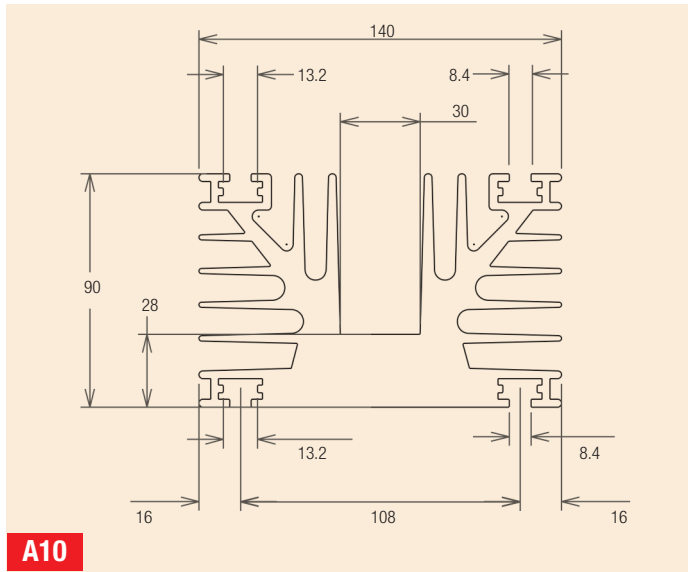
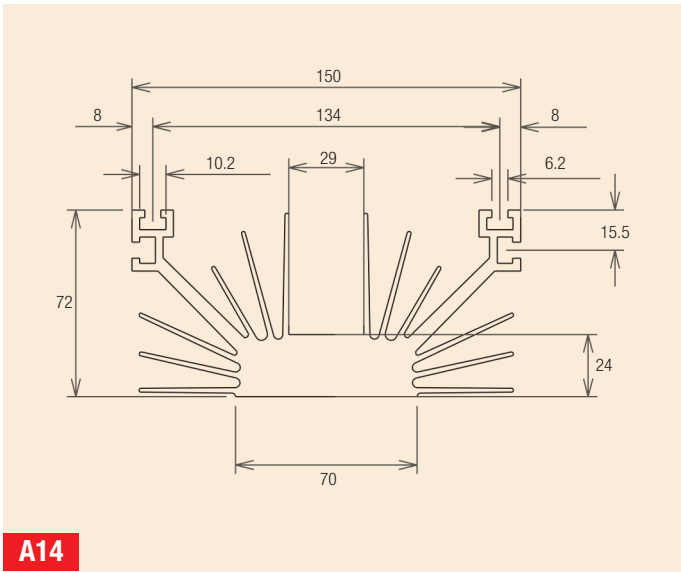

Press-Pack High Power Semiconductor

High Power insulated modules

Accessories

Heatinks and Cooling systems

Clamping systems

Power assemblies

Power converters and components for DC traction substations

Maintenance service

Main characteristics

They can be used to clamp in a reliable way the press-pack devices up to 150 mm diameter case. Mounting force calibration included. Customized design on request. Disc Springs (Belleville Spring) or torsion bars technologies



Clamp Code	Center distance I	Configuration	Mounting force F	Tie rod length L	Internal free space		Insulator length M	Insulator cap length M	Force distributing bar	Layout
					min S	max S				
	[mm]		[kN]	[mm]	[mm]	[mm]	[mm]	[mm]		

ACL standard family: disc spring technology

ACL70A12L150	70	A - Reverse without bar	12	150	104	113	160	38	no	KA
ACL70B12L150	70	B - Reverse on bar	12	150	89	98	160	38	no	KB
ACL70C12L150	70	C - Direct without bar	12	150	89	98	160	38	no	KC
ACL70D12L150	70	D - Direct on bar	12	150	89	98	160	38	no	KD
ACL89A12L150	89	A - Reverse without bar	12	150	100	109	90	24	no	KA
ACL89A18L110	89	A - Reverse without bar	18	110	60	69	70	24	no	KA
ACL89A19L150	89	A - Reverse without bar	19	150	100	109	90	24	no	KA
ACL89A21L150B	89	A - Reverse without bar	21	140	94	103	90	38	yes	KA
ACL89B12L150	89	B - Reverse on bar	12	150	85	94	90	24	no	KB
ACL89B18L110	89	B - Reverse on bar	18	110	45	54	70	24	no	KB
ACL89B19L150	89	B - Reverse on bar	19	150	85	94	90	24	no	KB
ACL89B21L150B	89	B - Reverse on bar	21	140	79	88	90	38	yes	KB
ACL89C12L150	89	C - Direct without bar	12	150	85	94	90	24	no	KC
ACL89C18L110	89	C - Direct without bar	18	110	45	54	70	24	no	KC
ACL89C19L150	89	C - Direct without bar	19	150	85	94	90	24	no	KC
ACL89C21L150B	89	C - Direct without bar	21	140	79	88	90	38	yes	KC
ACL89D12L150	89	D - Direct on bar	12	150	85	94	90	24	no	KD
ACL89D18L150	89	D - Direct on bar	18	110	45	54	70	24	no	KD
ACL89D19L150	89	D - Direct on bar	19	150	85	94	90	24	no	KD
ACL89D21L140B	89	D - Direct on bar	21	140	79	88	90	38	yes	KD

AK2 Double Disc Spring pack technology

AK2118B44L150B	118	B - Reverse on bar	44	150	44	50	95	30	yes	K2B
AK2140D18L110B	140	D - Direct on bar	45	210	83	98	140	30	yes	K2D

ACB High pressure family: torsion bar technology

ACB155D50L160B1	155	D - Direct on bar	50	160	83	93	160	34	yes	HK
ACB155D50L160B2	155	D - Direct on bar	50	160	83	93	160	34	yes	HK
ACB155D50L160B3	155	D - Direct on bar	50	160	83	93	160	34	yes	HK

AKI High pressure and insulated bar family:

AKI180B90L270	180	B - Reverse on bar	90	270	85	90	no	no	yes	KI
---------------	-----	--------------------	----	-----	----	----	----	----	-----	----

Ordering informations:

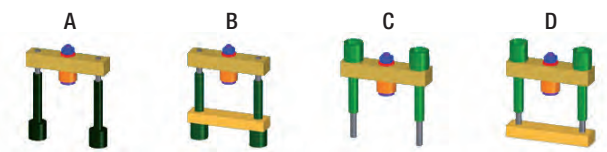
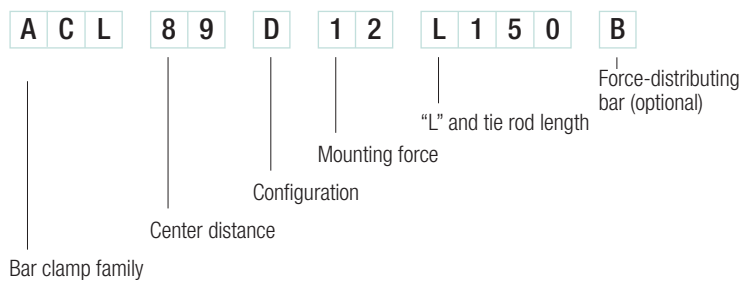

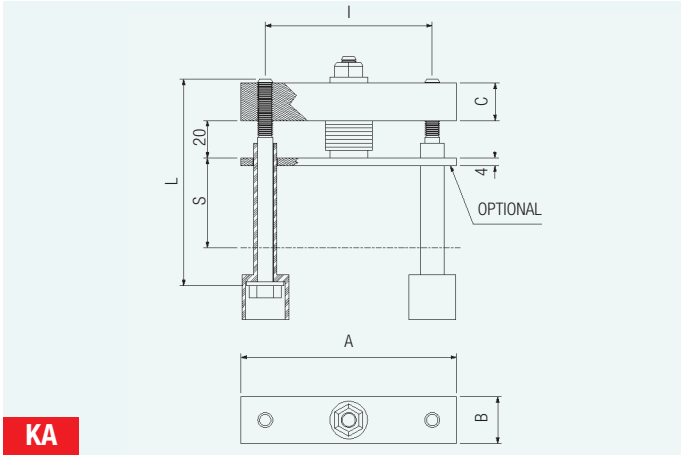

KA

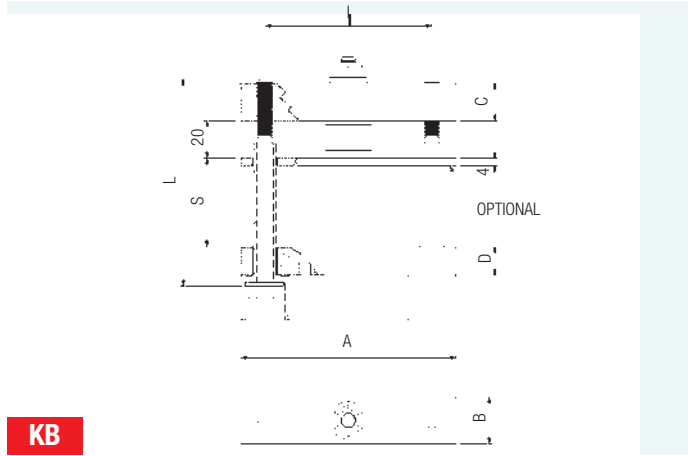

KB

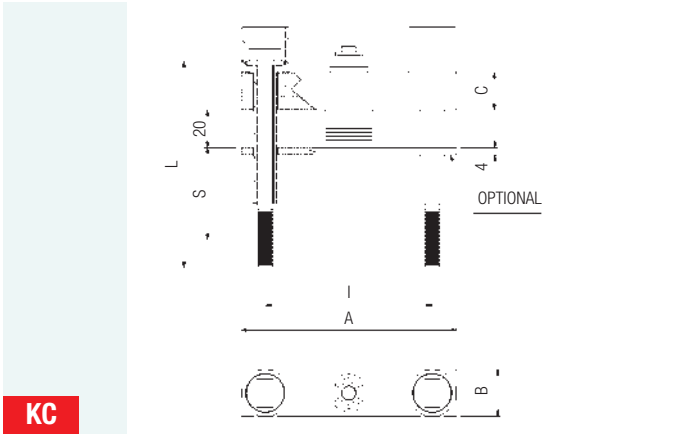

KC

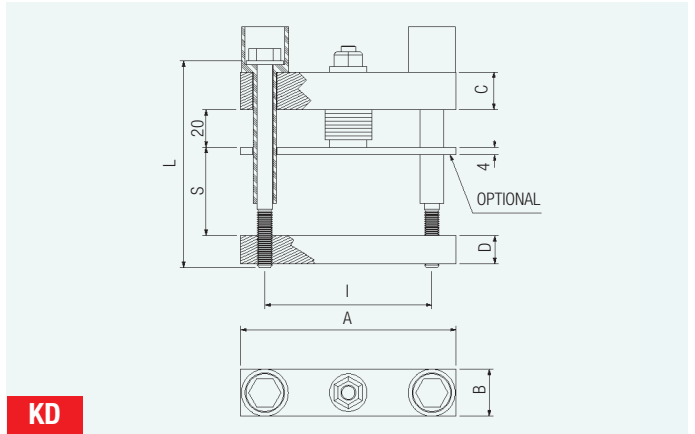

KD

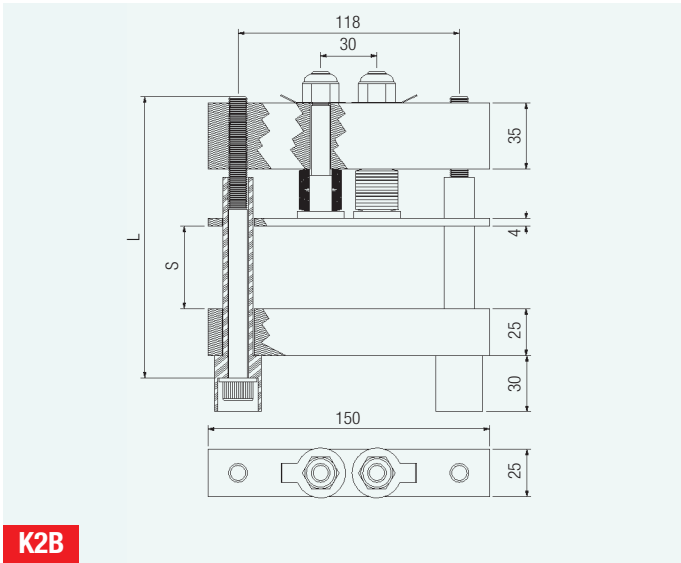

K2B

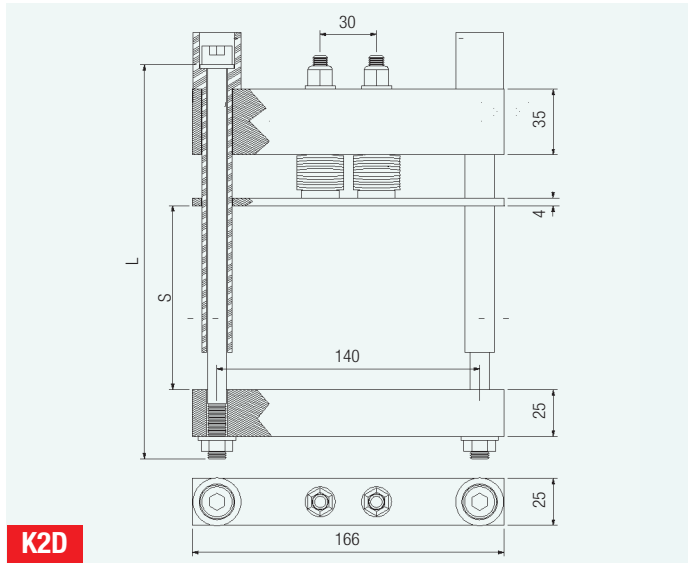

K2D

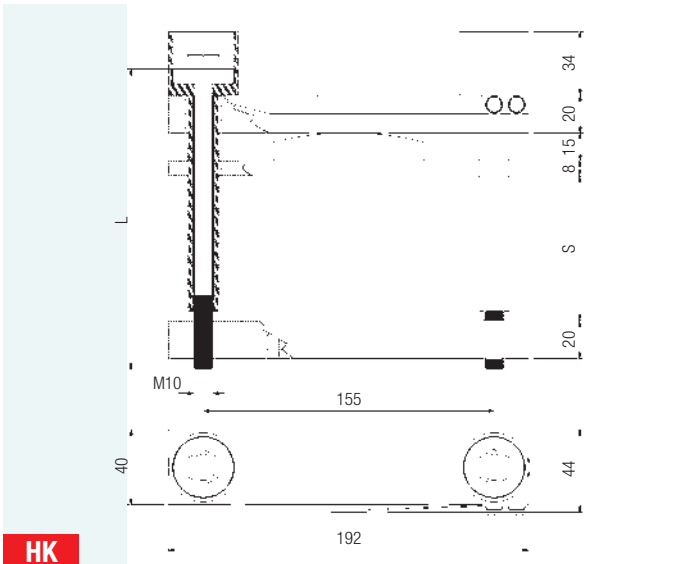

HK

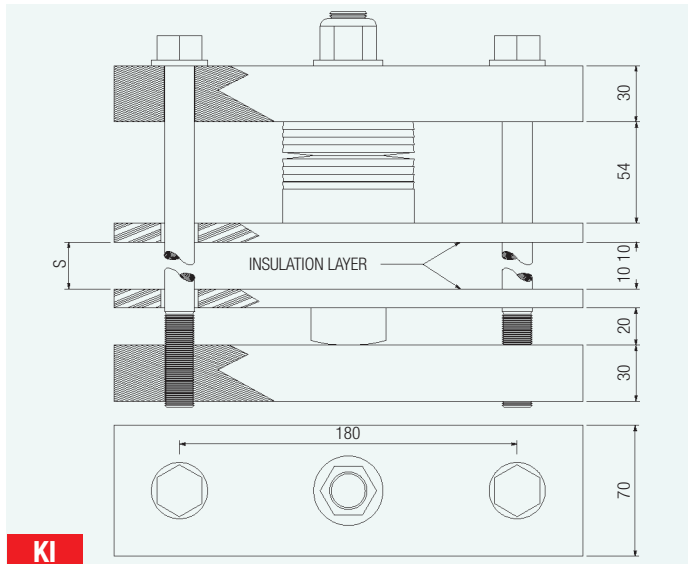

KI

Press-Pack High Power Semiconductor

High Power insulated modules

Accessories

Heatsinks and Cooling systems

Clamping systems

Power assemblies

Power converters and components for DC traction substations

Maintenance service

Main characteristics

Full insulated clamp system with high mechanical performance and high reliability
 Custom design on request with different rod length, mounting force and centers distance

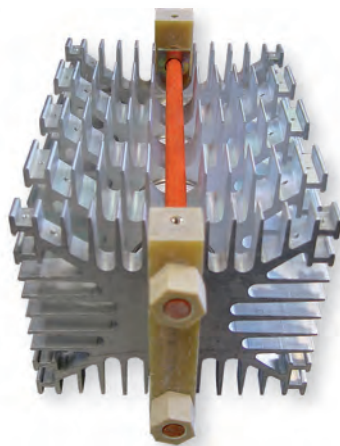

Full insulated clamp system

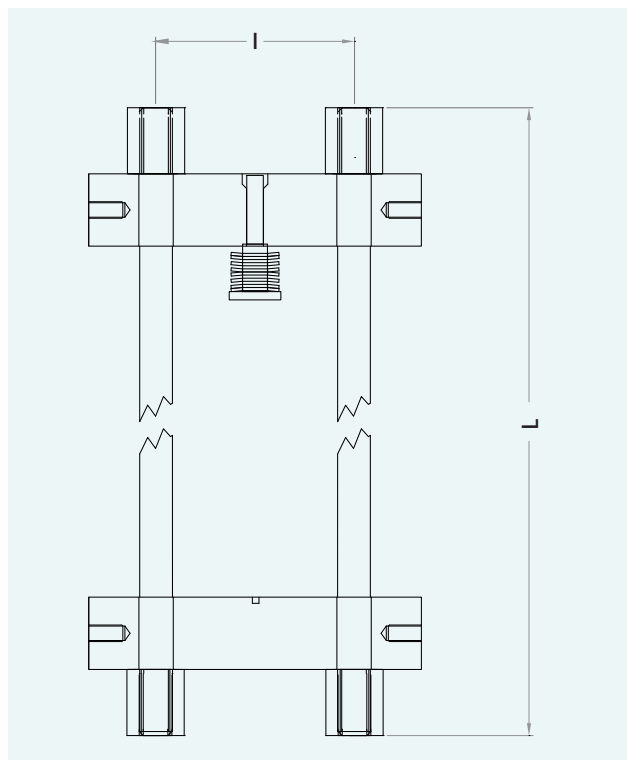

Clamp Code	Centers distance l	Mounting F	Tie rod length L
	[mm]	[kN]	[mm]
AIC89F12L330B	89	12	330

Customized solution on request applying the following ordering information:

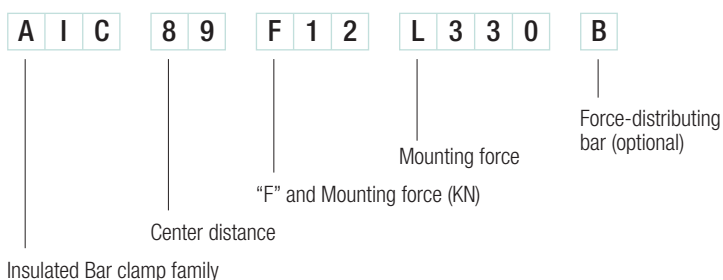

Insulators for clamp rod ties

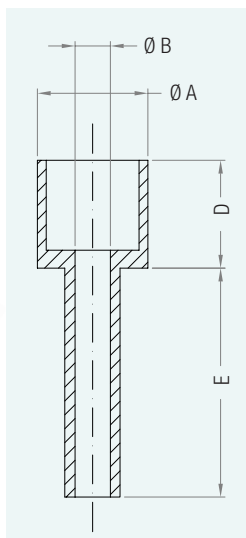

Insulator Code	Rod type	Ø A	Ø B	D	E
		[mm]	[mm]	[mm]	[mm]
AIR2524M08	M8	25	8,5	24	80
AIR2538M08	M8	25	8,5	38	80
AIR2530M10	M10	25	10,5	30	80
AIR3734M10	M10	37	10,5	34	80
extension rod M8	M8	-	8,5	-	80
extension rod M10	M10	-	10,5	-	80

Main characteristics

- Easy to assembly box clamping system
- Custom design
- Variable clamping force from 5 to 12 KN

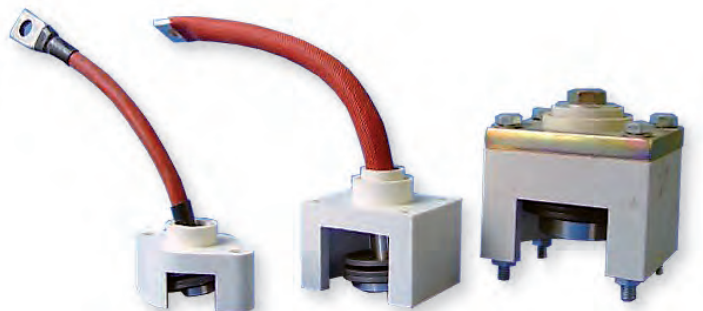

Box clamp code	Length	Width	Height	Maximum internal diameter Φ	Mounting force F	Device height S	See outline
	L [mm]	W [mm]	H [mm]				
ABC045F140	46,0	46,0	32,0	42	4,5	14,0	A
BBC080F146	58,0	58,0	71,5	38	8,0	14,6	B
CBC125F268	58,0	70,0	71,5	A	12,5	26,8	C
CBC089F268	58,0	70,0	71,5	38	8,9	26,8	C
CBC125F221	58,0	70,0	71,5	38	12,5	22,1	C

Available Box Clamp Types:



Type A
46.0 mm x 46.0 mm



Type B
58.0 mm x 58.0 mm
Type C
58.0 mm x 70.0 mm

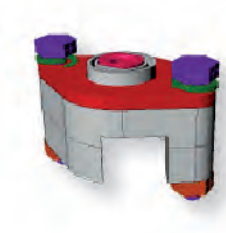

Type D
60.0 mm x 80.0 mm

Ordering informations:

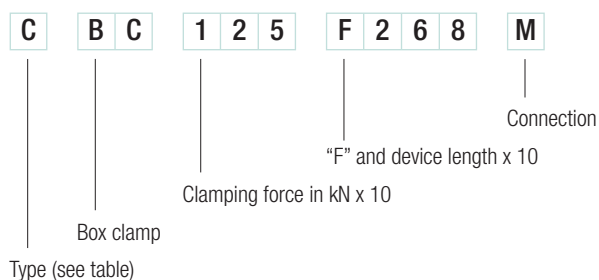

Types of upper connection:

- M Male thread
- F Female thread
- T Copper plait
- B Copper bar

Main characteristics

Using proprietary devices as well as semiconductors and water heatsinks
 High power density, high efficiency and reliability
 Custom design available
 Natural / forced air cooling or water cooling system
 Semiconductors: Thyristors, Diodes, GTOs and IGBT's (insulated modules and press-pack type)
 Field technical support available
 Connection technology both copper and aluminium

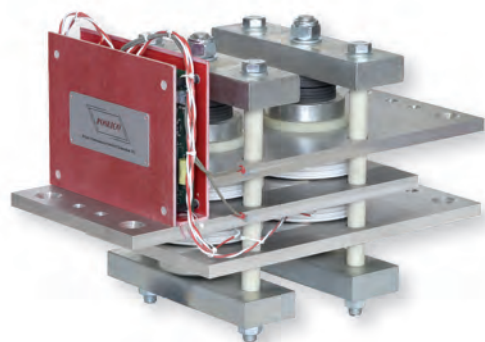

Description	POSEICO code	Device type	Circuit type	Main characteristics	Outline
Stack with single diode	2H6.../2H9...	Diode	Diode	Natural air	A
Diode stack mounted in plastic container for outdoor applications	ADP.....	Diode	Diode	Natural air	B
Crow bar for traction application	RCB	Diode + Thyristor	Crow bar	Natural air , pulsed works	C
High voltage stack with diodes in serie	ASA	Diode	Diodes in serie	Natural air	D
Thyristor stack	ASA.....	Thyristor	Controlled 3 phase rectifier	Water cooling heatsink	E
Three phase bridges	APR ...	Diode	Rectifier three phase bridges	Natural air	F
Stack with fast thyristor and forced air cooling system	ASI.....	Thyristor	Two thyristors in serie	Air forced cooling	G
Three phase controlled bridges	APR ...	Thyristor	Controlled 3 phase bridges	Water cooling heatsink	H
Inverter leg Module	AINV..	Press pack IGBT + Fast and soft recovery diodes	Inverter leg	Water cooling heatsink	I
Inverter leg Module	AINV..	IGBT and FW Diode module	Inverter leg	Water cooling heatsink	L

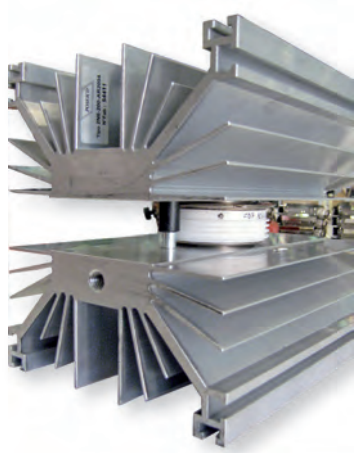

A Stack with single diode and bilateral natural air aluminium heatsink



B Stack with single diode, natural air aluminium heatsink mounted plastic container watertight

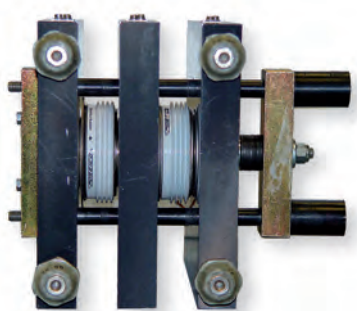

C Crow bar

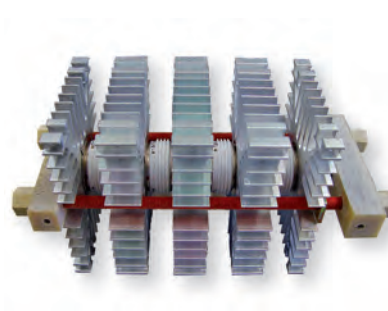

D Stack with 4 diodes connected in series using an insulated clamp system

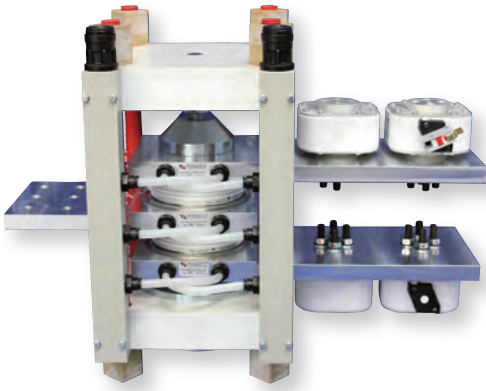

E Water cooled power assembly for high power supplies

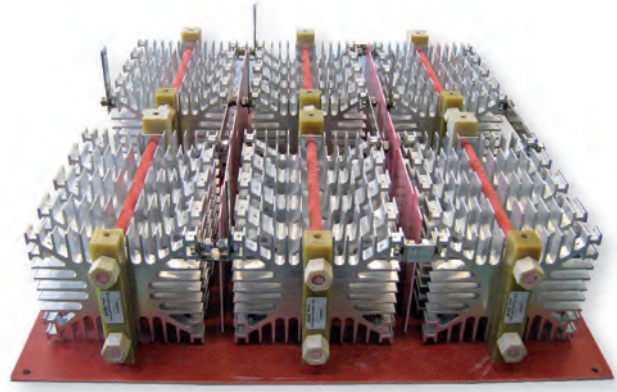

F Three Phase bridge, 4 diode for arms, full insulated clamp

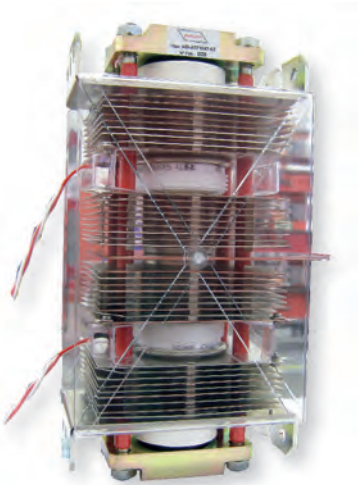

G Stack with two fast thyristors, air forced cooling system, four tie rod clamp

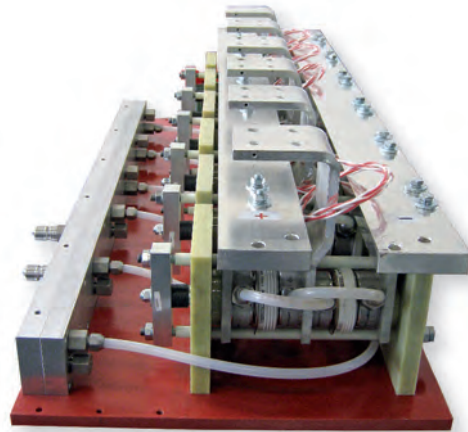

H Controlled three phase bridge cooled by Deionized Water

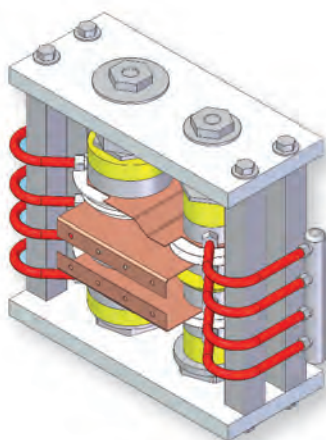

I Inverter leg assembly with Press pack
Free wheeling and snubber diode and water cooling system



L IGBT Module for inverter application

Press-Pack High Power Semiconductor

High Power insulated modules

Accessories

Heatsinks and Cooling systems

Clamping systems

Power assemblies

Power converters and components for DC traction substations

Maintenance service

Main characteristics

- Assemblies containing two thyristors connected back to back
- Rated Irms current for ED = 100% operations
- 4 L/min typical water flow rate
- Customized busbars connections on request
- Customized water connections on request
- Single side cooling on request

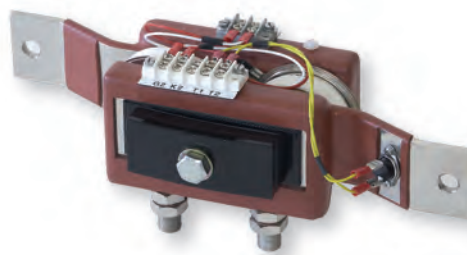

Water cooled AC switches	Water insulation	VDRM VRRM	IRMS Twater	ITSM	I ² t Tjmax	VG/IGT Tj=25°C	VT(TO) Tjmax	rT Tjmax	Rth	Tjmax	Max water	Outline
		[V]	[A/°C]	[kA]	[A ² ·s·10 ³]	[V]	[V]	[mΩ]	[°C/W]	[°C]	[bar]	
2-2W4-P	no	1600	1170/30(1)	8,4	353	3,5 / 200	0,93	0,64	0,1	125	10	X0
2-2W5-PI	Al2O3 disks	1600	1275/30(1)	8,4	353	3,5 / 200	0,93	0,64	0,09	125	10	Y0
2-2WI-600	elastomer	1600	730/40	5,6	157	3,5 / 200	1	0,68	0,25	125	10	W0
2-2WI-1000	elastomer	1600	1100/40	8,8	387	3,5 / 200	0,91	0,58	0,18	125	10	W0
2-2WI-1200	elastomer	1600	1290/40	12,5	781	3,5 / 250	1	0,38	0,14	125	10	W0
2-2W5I-AT505	elastomer	1600	625/40	5,6	157	3,5 / 200	1	0,68	0,3	125	10	W1
2-2W5I-AT603	elastomer	1600	880/40	8,8	387	3,5 / 200	0,91	0,58	0,21	125	10	W1
2-2W5I-AT804	elastomer	1600	1120/40	12,5	781	3,5 / 250	1	0,38	0,17	125	10	W1
2-2W5I-AT1004	elastomer	1600	1550/40	24,6	3026	3,5 / 300	0,92	0,216	0,13	125	10	W1
2-2W5I-AT636	elastomer	1800	1810/40	36	6480	3,5 / 300	0,82	0,18	0,12	125	10	W1

(*) water flow rate: 5 l/min

Type	2-2W5I-AT505 2-2W5I-AT603	2-2W5I-AT804	2-2W5I-AT1004 2-2W5I-AT636
A	130	140	160
B	5	6	6
C	60	70	70
D	230	230	250
E	130	130	150
F	64	74	84
G	40	40	50
spring	1+1	2+2	2+2

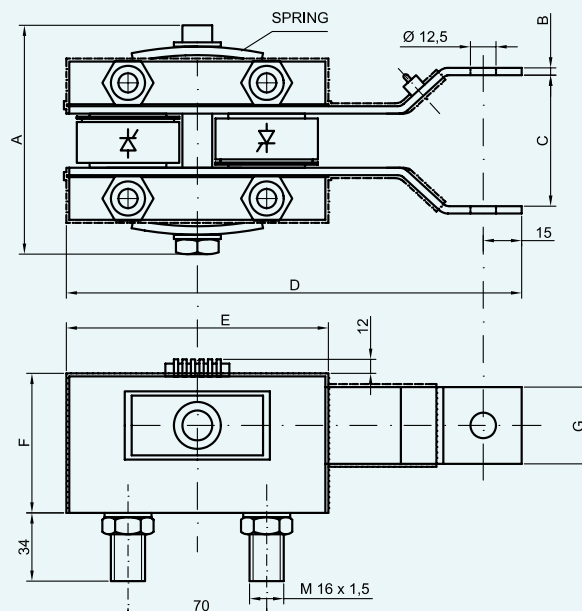

W1

X0

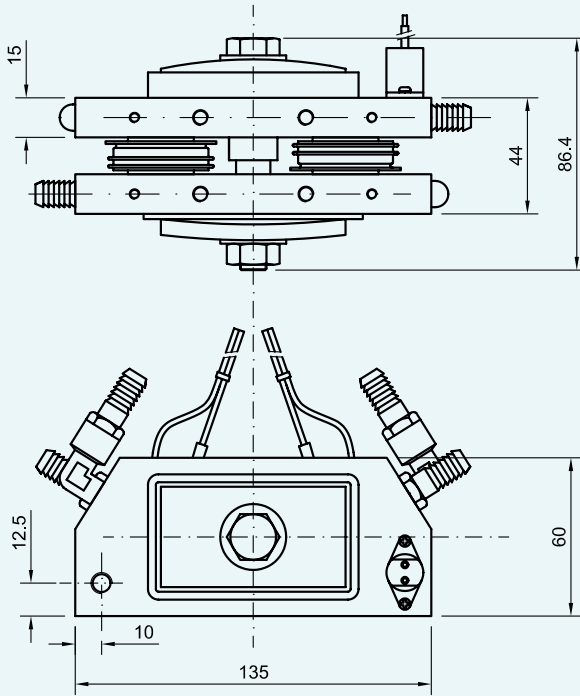

Y0

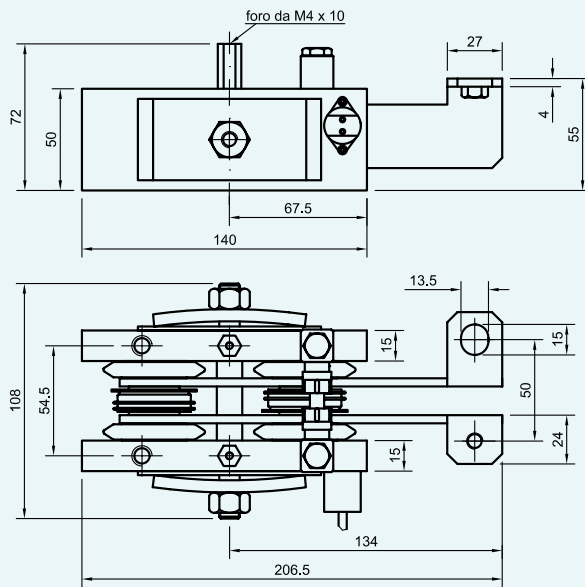

W0

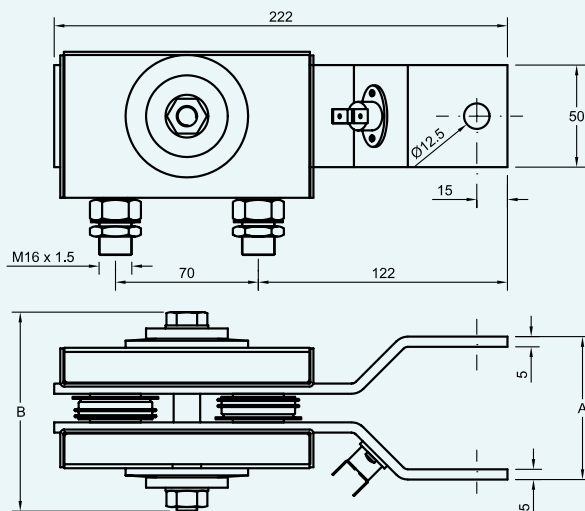

	2-2WI-600	2-2WI-1000	2-2WI-1200
A	98	98	109.5
B	70	70	81.5

Press-Pack High Power Semiconductor

High Power insulated modules

Accessories

Heatsinks and Cooling systems

Clamping systems

Power assemblies

Power converters and components for DC traction substations

Maintenance service

Power conversion products



Power assemblies and converters for electric traction system



Converters for renewable energy

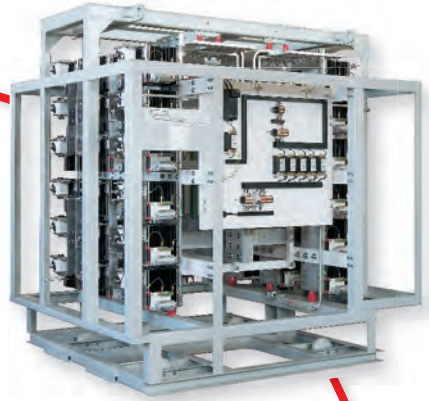

Rectifier bridges for catenary line supply



Industrial Drives and power supply

Converter division of Poseico places own long time experience in power electronics at our Customers disposal.

Since 1970, Poseico has leading technology in high power semiconductors (diodes, SCRs, GTOs and IGBTs) and high efficiency thermal management. As converter division, we practically cover all application fields where our components are commonly employed, as well as traction, industrial (current rectifying, power conversion, AC power control and regulation), and renewable energy applications, for high voltage and/or high current ranges.

Some examples, but not limited to, are:

- High current/power AC/DC diode or SCR rectifiers in bridge or double star connection,
- Single or three phase inverters,
- AC static switches,
- High power supply in DC or AC.

At Customer convenience, we can design and supply from simple power assembly (stacks, bridges, legs) up to the complete package, including its own OEM controls and cooling system. At last we are able to specify, select and supply, only from first class third parties, other equipments as well as special converter transformers, reactors, filters and switchgears.

All designs are according with the most important international standards.

Customer can enjoy the very open Poseico style because we can work together side by side, in team or, more usual, fulfilling Customer's technical specification, providing standard or tailor-made solutions.

The Customer can experience a high level technical staff inside Poseico that manage its problems, using the latest up-to-date technical tools (3D CAD, simulators, DSP, microcontroller), finding the most competitive and high quality solution.

Our goal is the complete Customer satisfaction. We can help and support him with an efficient service for commissioning, erection supervision, start up and after sales support. In case, we are available for refurbishment, overhaul or revamping of existing equipment.

Choice Poseico when you need problem solving, high quality and reliability, long lasting equipment, competitive price, the best time-to-market, qualified experience and high level skills in power electronics.

Try us! Send a request or placing your question. We are proud in serving you.

Press-Pack High Power Semiconductor

High Power Insulated modules

Accessories

Heatsinks and Cooling systems

Clamping systems

Power assemblies

Power converters and components for DC traction substations

Maintenance service

POSEICO designs, manufactures and trades a large number of components and devices for DC traction substations for trolley bus, tramway, metro and rail applications as:

- 6, 12 and 24 pulses Traction rectifiers.
- Negative disconnector cubicles
- Positive disconnector cubicles
- Voltage limiting device (VLD-O type)

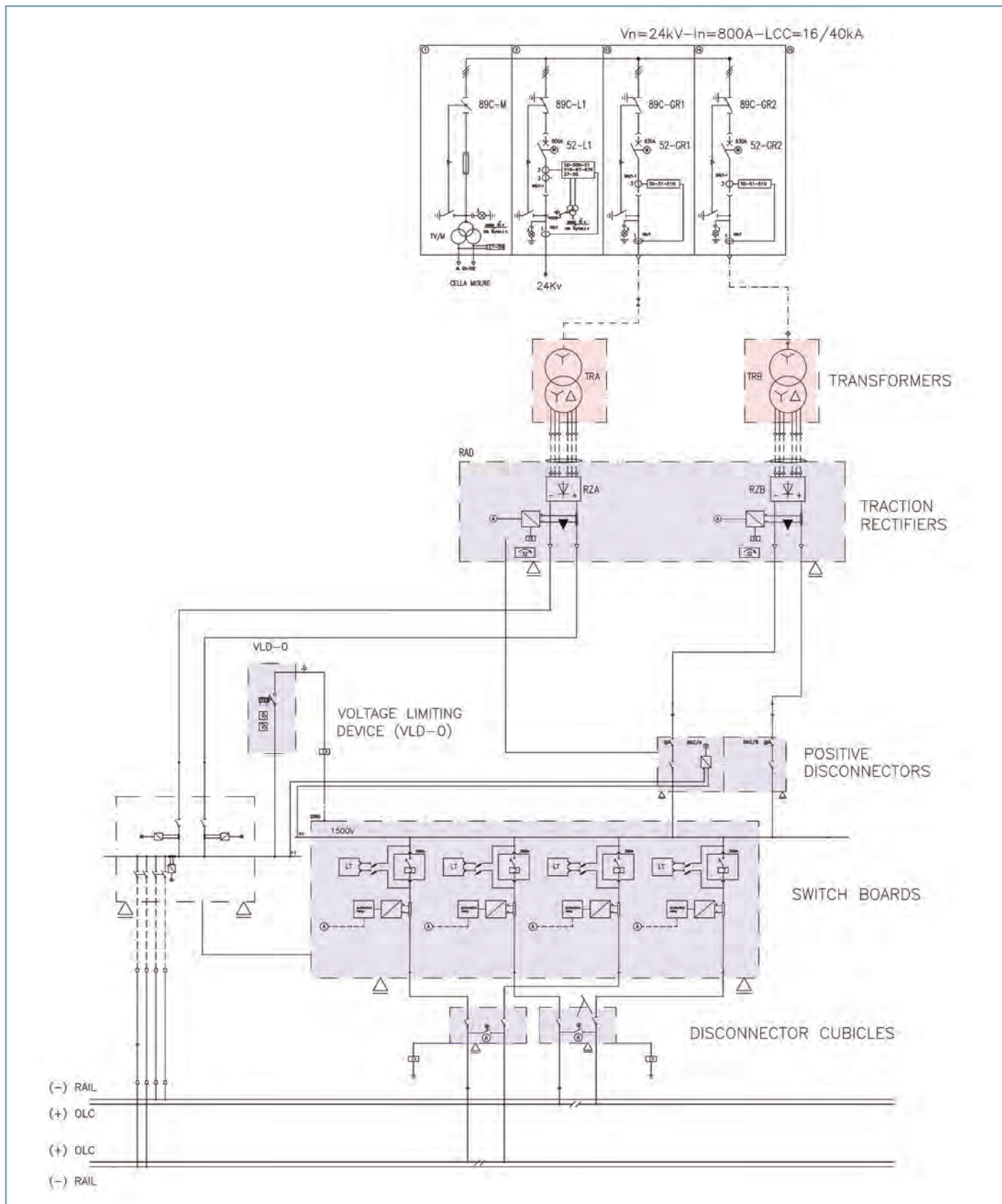

Typical schematic of a traction electrical substation

- Poseico components
- Poseico supply

Press-Pack High Power Semiconductor

High Power insulated modules

Accessories

Heatinks and Cooling systems

Clamping systems

Power assemblies

Power converters and components for DC traction substations

Maintenance service

Main characteristics

Output power range from 500 up to 7200 kW
Output nominal voltage (EN50163):
600, 750, 1500, 3000 Vdc.
other output voltages are available on request.
Mechanical construction criteria include open frame and metallic cubicle structures as well as fixed or withdrawable solutions.
The power semiconductor diodes of the press-pack technology are manufactured by POSEICO S.p.A.
Careful monitored protection systems are designed to protect the rectifiers against overvoltages, overcurrents and overtemperatures.
The main applications are as energy supply in light, medium and heavy power traction systems.
The rectifiers are designed and manufactured by POSEICO S.p.A. under its Quality System Certified according ISO9001:2008 and IRIS Rev02.

Reference Standards:

EN 50327, EN 50328 and EN50329

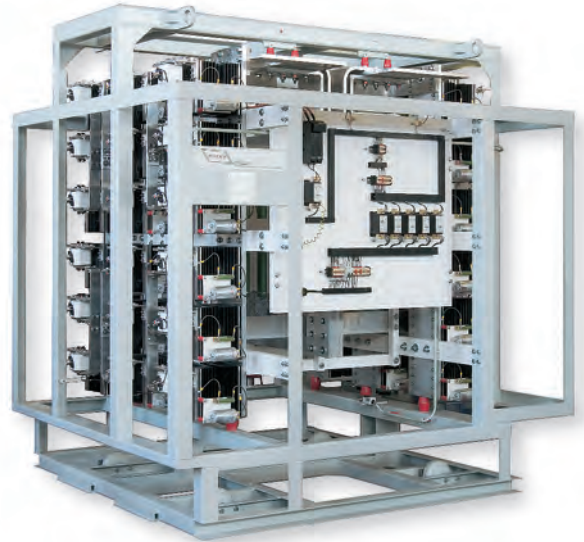

Since 1980, POSEICO started, in parallel with its production of power semiconductor devices, to manufacture power rectifiers for traction applications.

The big experience in power electronics and the care in the customer's satisfaction, allowed POSEICO to expand this activity becoming one of the leader in this field. POSEICO is a reliable supplier of traction rectifiers for the main European railways, metro and tram lines. In 2010 in order to satisfy the increasing demand and to offer a more and more efficient service, POSEICO moved the rectifier production to a new facility located in Busalla (20 km far from the head quarter located in Genoa) of 2500 m² assembling area having a testing room with the possibility to test 6 - 12 and 24 pulse rectifiers up to 4000V and 15000 A.

POSEICO RECTIFIER CHARACTERISTICS

POSEICO can design, manufacture and test rectifiers for all DC voltages traction systems according to EN50163 Standard:

- 600 V DC
- 750 V DC
- 1500 V DC
- 3000 V DC

other output voltages are available on request.

The power starts from 600KW up to 7.2MW

It's possible to offer every type of solution: open frame, closed cubicle, withdrawable solutions.

The rectifiers are designed, manufactured and tested according to the EN50328 and IEC 60146-1 Standards.

Normally the rectifiers are natural air cooled to increase reliability and service continuity.

On request, it is possible to have air forced or water cooled rectifiers.

The basic solution is a 6 pulse rectifier (three phase Graetz bridge) but, to minimize the harmonic distortion, it is possible to supply 12 pulse or 24 pulse rectifiers. Moving to 12 or 24 pulse configurations the choice of the transformer technical characteristics becomes fundamental. POSEICO can support its customers in the definition of the transformer technical specification and is able to supply complete rectifier groups: rectifier + transformer(s) including bus bars electrical connections among them.

The rectifier can be manufactured with or without fuses based on customer's request; the fuses allow, in case of internal fault of the rectifier (one diode failed), to interrupt the short circuit current.

The rectifier can have a different number of diodes in parallel or in serie for arm.

This last solution is adopted when the power is too big for only one diode or in case of redundancy request.

In case of redundancy the fuse is designed not only to interrupt the short circuit current due to internal fault but to assure the selectivity of the system too.

In case of 3KV applications POSEICO can assure the redundancy using both diodes in series connection and diodes in parallel connection in each arm. In both cases, the POSEICO experience in high power semiconductor manufacturing allows to have an extremely accurate component matching to minimize the unbalance in voltage or in current respectively.

Electrical characteristics

Type of connection		N° 8,9,12 tb.4 EN50328		
Nominal Voltage	V	750	1500	3000
Ideal no Load Voltage	V	796	1800	3600
Insulation Test Voltage	KV	4.6	9.2	18.5
Frequency	Hz	50/60		
Nominal Current	A	500÷4000	500÷4000	100÷4000
Diodes in series per arm		1	1	1÷5
Diodes in parallel per arm		1÷4		
TYPE OF REDUNDANCY (immunity level EN 50328)		R (No loss of performance) F (Loss of performance) T (interruption of service due to protective devices) D (interruption of service due to damage)		
Diode Failure Monitoring		Alarm System Unit		
Pollution Degree		PD3A (EN 50124-1)		
Protection Degree		IP00÷IP55		

The rectifiers are protected from overvoltage coming from DC and AC side by RC circuits with or without fuses.

The rectifier in standard configuration has the following signals:

- Temperature alarm
- Temperature trip

In case of fuse in series connection with each diode:

- diode alarm (in case of one diode failed in each arm)
- diode trip (in case of a second diode failed in one arm)

The signals are available on the terminal block . As option it is possible to connect all the signals to a PLC and transmit them via SCADA.

It is also possible to have the voltage and current measurements displayed on the front of the cubicle and/or transmitted via SCADA.



METRO application 3.6MW-1500V
Withdrawable solution



RAILWAY application 6.6MW 1500V 24 pulses
Complete rectifier group: rectifier + transformers including bus bar connections among them

Rectifier Bridges for Traction Applications

Press-Pack High Power Semiconductor

High Power Insulated modules

Accessories

Heatinks and Cooling systems

Clamping systems

Power assemblies

Power converters and components for DC traction substations

Maintenance service

Rectifier for traction applicatios	Protection degree	Type of connection	Conven-tion at power	Nominal voltage	Nominal current	Rectifier Diodes POSEICO type	Number of arms	Diodes in series per arm	Diodes in parallel per arm	Total diodes quantity	Weight	Refer-ences Photo
			[kW]	[V]	[A]						[kg]	

Nominal Voltage 750 V; natural air cooling

RA6442	IP00	EN50328 N° 8 tab.4	500	750	666	AR1104S22	6	1	1	6	210	
RA6443	IP00	EN50328 N° 8 tab.4	520	575	900	AR3004S25	6	1	1	6	230	
AR6613	IP00	EN50328 N° 8 tab.4	750	750	1000	AR3004S25	6	1	1	6	260	
RA6441	IP00	EN50328 N° 8 tab.4	800	750	1066	AR2004S22	6	1	1	6	230	
AR6612	IP00	EN50328 N° 8 tab.4	900	750	1200	AR3004S22	6	1	1	6	260	2
AR6614V	IP30	EN50328 N° 8 tab.4	900	750	1200	AR749LTS22	6	1	1	6	400	
AR6614	IP00	EN50328 N° 8 tab.4	1000	750	1333	AR749LTS22	6	1	1	6	280	
RA6701D	IP00	EN50328 N° 9 tab.4	1200	750	1600	AR3004S22	12	1	1	12	525	
RA6455	IP00	EN50328 N° 8 tab.4	1500	750	2000	AR2004P24	6	1	4	24	806	
RA1560	IP00	EN50328 N° 8 tab.4	1500	750	2000	AR749LTS22	6	1	1	6	460	
RA6651	IP32	EN50328 N° 8 tab.4	2500	750	3333	AR749LTS22	6	1	3	18	1500	
RA3901D	IP00	EN50328 N° 9 tab.4	3000	750	4000	AR748LTP22	12	1	2	24	1780	
RA3901E	IP00	EN50328 N° 8 tab.4	3000	750	4000	AR748LTP22	6	1	3	18	1730	
RA3911E	IP00	EN50328 N° 8 tab.4	4000	750	5333	AR748LTP22	6	1	4	24	1890	

Nominal Voltage 1500 V; natural air cooling

AR6615	IP00	EN50328 N° 8 tab.4	900	1200	750	AR3008S32	6	1	1	6	300	
RA6447	IP00	EN50328 N° 8 tab.4	1500	1500	1000	AR770LTS24	6	1	1	6	330	
AR6625	IP00	EN50328 N° 8 tab.4	1650	1650	1000	AR1104P26	6	1	4	24	400	
RA3640E	IP31	EN50328 N° 42 tab.4	3000	1500	2000	AR2004P24	12	1	4	48	2200	5
RA3610	IP00/IP32	EN50328 N° 12 tab.4	3500	1500	2333	AR1104P21	12	1	4	48	1800	
RA1531D	IP00	EN50328 N° 9 tab.4	4000	1500	2667	AR772P44	12	1	2	24	1850	
RA1531E	IP00	EN50328 N° 8 tab.4	4000	1500	2667	AR772P44	6	1	3	18	1700	
RA1631D	IP00	EN50328 N° 9 tab.4	5000	1500	3333	AR772P44	12	1	3	36	2050	
RA1631E	IP00	EN50328 N° 8 tab.4	5000	1500	3333	AR772P44	6	1	4	24	1850	
RA1320NG	IP00	EN50328 N° 12 tab.4	6600	1650	4000	AR3004P26	12	1	4	48	2x1030	
RA1340P/N	IP00	EN50328 N° 12 (x2)	6600	1650	4000	AR1104P26	24	1	4	96	4x875	4

Nominal Voltage 3000 V; natural air cooling

RA1651NG3600	IP00	EN50328 N° 9 tab.4	3600	3000	1000	AR3007S30	12	5	1	60	2x515	
RA1552	IP00/IP32	EN50328 N° 12 tab.4	5100	3400	1500	AR771S50	12	1	1	12	2x500	
RA1651NG5400	IP00	EN50328 N° 9 tab.4	5400	3000	1500	AR3008S30	12	5	1	60	2x555	3
RA1851	IP21	EN50328 N° 12 tab.4	7400	3000	2468	AR772P50	12	1	3	36	2000	1

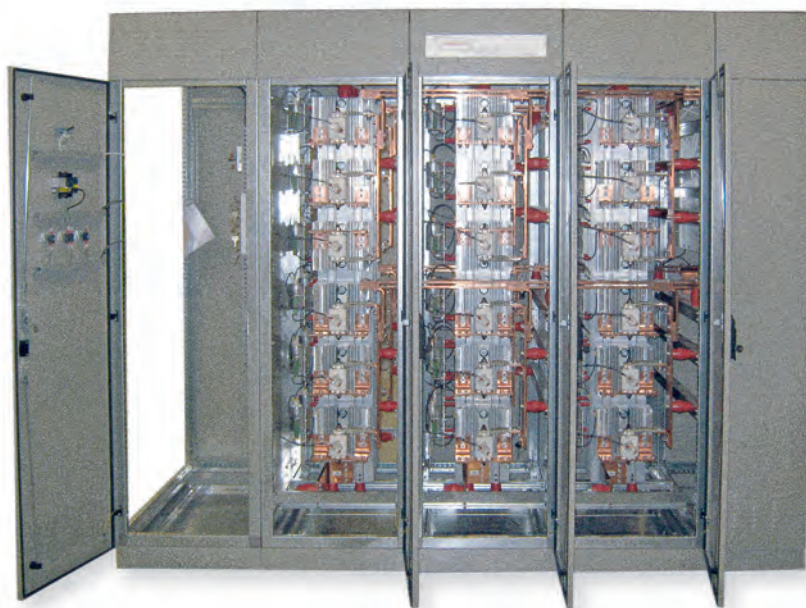

1 Rectifier Units for Railway Application - Nominal Voltage 3000 V - 7400 kW - 12 pulse

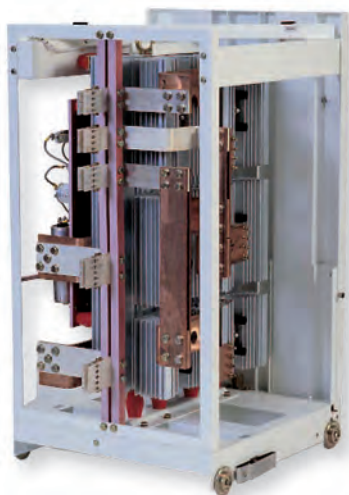

2 Rectifier Units for Tram or Trolley bus application
Nominal Voltage 750V - 1000 kW - 6 pulse

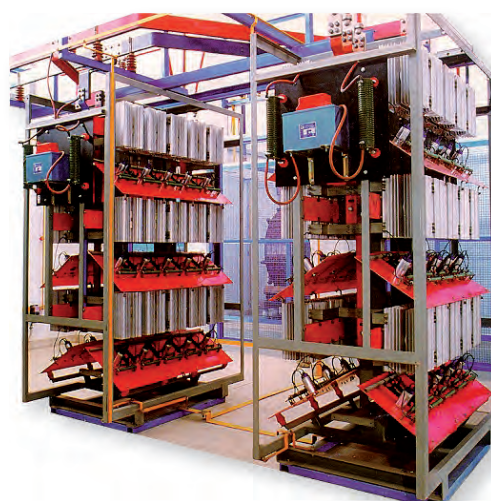

3 Rectifier Units for Italian Railway
Nominal Voltage 3000V - 5400 kW - 12 pulse

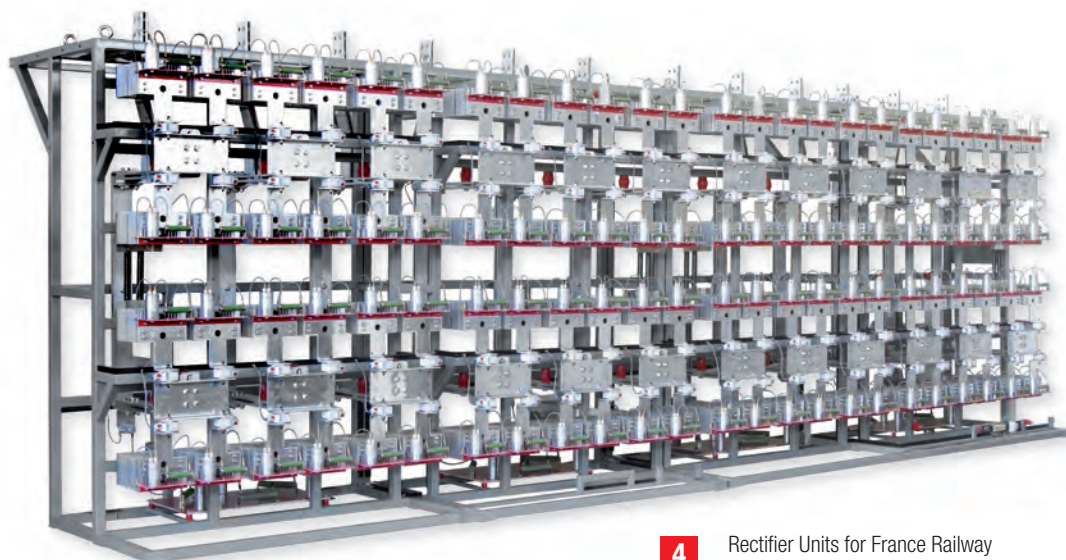

4 Rectifier Units for France Railway
Nominal Voltage 1650V - 6600 kW - 24 pulse



5 Rectifier Units for Metro Application - Nominal Voltage 1500 V - 3000 kW - 12 pulse

Press-Pack High Power Semiconductor

High Power insulated modules

Accessories

Heatinks and Cooling systems

Clamping systems

Power assemblies

Power converters and components for DC traction substations

Maintenance service

Voltage Limiting Device (VLD-O type)



Main characteristics

The voltage limiting device function is to control the voltage of the RAIL (negative polarity) in d.c. traction systems according to the EN 50122-1 Standard (2011 Edition).

Its structure consists of two main devices connected in parallel:

- One electromechanical switch
- One electronic switch (SCRs technology).

Reference standard

- EN 50122-1 (2011 Edition)
- EN 50124-1
- EN 50123-1,3,6,7
- Insulating materials: NEMA LI-1 GPO3, EN 60893
- Wiring materials: CEI UNEL 35368, CEI 20-38, 20-37, 20-22 II, 20-3

Voltage limiting devices	Protection degree	Nominal voltage	Nominal current	Making capacity	Braking capacity
		[V]	[A]	[kA]	[A]

Nominal Voltage 750 V; natural air cooling

ADMTN 50-08-A	IP21	750	1000	30	1000
---------------	------	-----	------	----	------

Nominal Voltage 1500 V; natural air cooling

ADMTN100-15	IP21	1500	2500	60	1000
-------------	------	------	------	----	------

Comparison among the standard EN50122-1 (2011 Edition) requirements and the performances of the ADMTN 50-08

- ADMTN 50-08-A
- Ub, max (V)
- Ute, max (V) long-term
- Ute, max (V) short-term

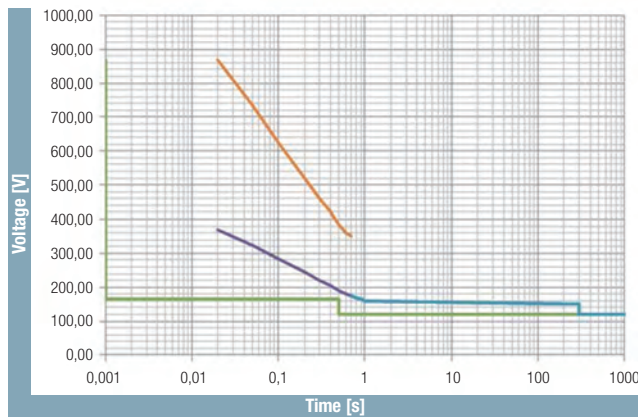

Schematics

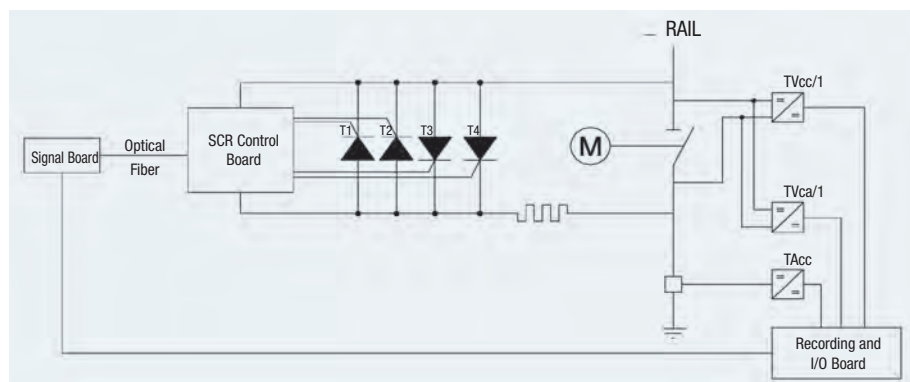

Main characteristics

Output current range from 500 up to 4000 A
 Output nominal voltage (EN50163): 750,1500,Vdc.
 Others output voltages are available on request
 Mechanical construction criteria include open or closed units.
 Custom design
 Manual or Motor operated switches with manual emergency operation.
 Mechanical interlocking
 Current / voltage Measurement
 Ground fault protection (64)
 The main applications are for energy supply of light, medium and heavy power traction systems
 The cubicles are designed and manufactured by POSEICO S.p.A. under its Quality System Certificated ISO9001:2008 and IRIS Rev02

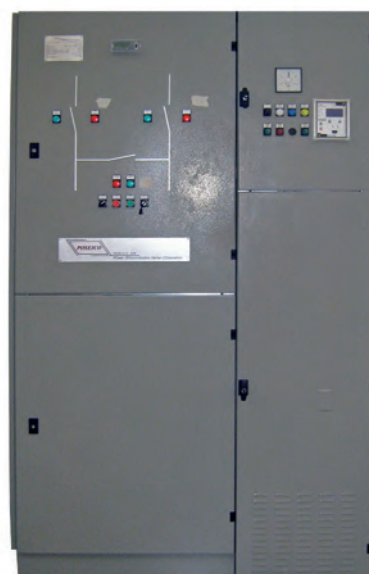

Disconnector Cubicles for traction applications	Protection degree	Nominal voltage	Nominal current	Short circuit current (250ms)	Short circuit current peak	Number of disconnectors	Type of disconnectors	Schematics
		[V]	[A]					

Nominal Voltage 750 V; natural air cooling

AQS-13-8-3	IP21	750	1900	50	70	2	Manual	Q1
AQS-13-8-6	IP21	750	1900	50	70	4	Manual	Q2
AQS19-8-1	IP55	750	1900	50	70	1	Motor operated switches with manual emergency operation	Q3

Nominal Voltage 1500 V; natural air cooling

AQS-30-15-2	IP21	1500	3000	60	100	2	1 Manual - 1 Motor operated switches with manual emergency operation	Q4
AQS-30-15-3	IP21	1500	3000	60	100	3	2 Manual - 1 Motor operated switches with manual emergency operation	Q5

Schematics

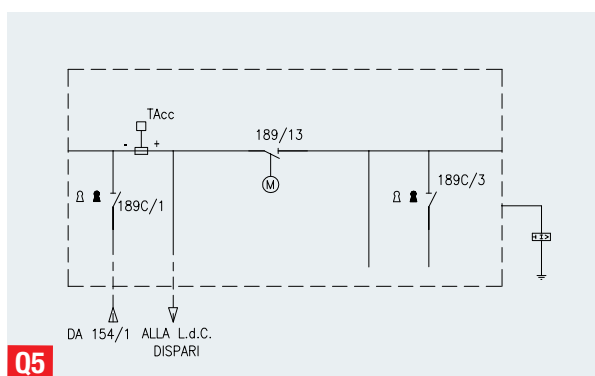
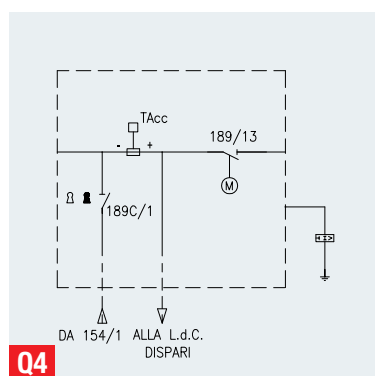
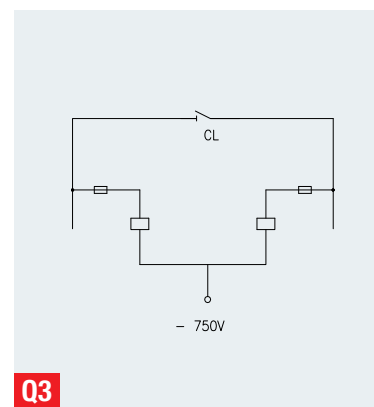
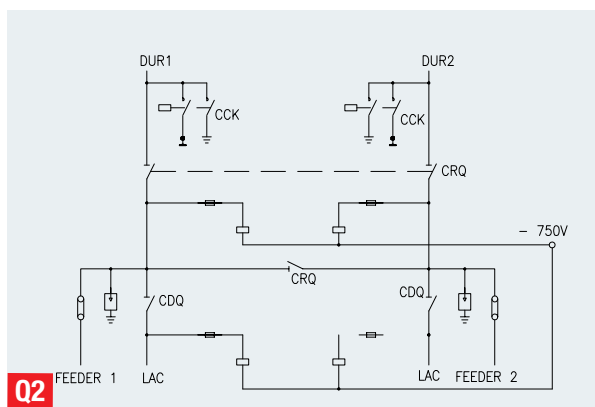
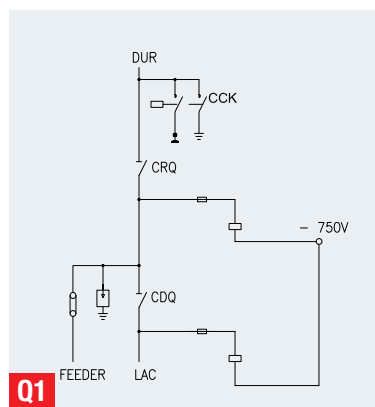

Main characteristics

Output power range from 500 up to 2000 kW.

Customer configurations:

- AC -switch converters with SCR devices
- Three-Phase Controlled Rectifiers with SCR devices
- Three-Phase Controlled Rectifiers with IGBT devices
- Three-Phase Inverters with SCR devices
- Three-Phase Inverters with IGBT devices
- AC/AC Frequency converter with IGBT devices



Output nominal voltage: from 400V ac up to 16kVdc.

Mechanical construction criteria include open frame and metallic cubicle structures as well as fixed or withdrawable solutions.

Careful monitored protection systems are designed to protect the converters against overvoltages, overcurrents and overtemperatures.

The rectifiers are designed and manufactured by POSEICO S.p.A. under its Quality System Certificated according ISO9001:2008 and IRIS Rev02.

Reference Standards: EN 60146

Power converter	Protection degree	Type of converter	Semiconductor type	Nominal input voltage	Nominal output voltage	Conventional power	Application	Weigth	Outline
				[V]	[V]	[kVA]		[kg]	
ACF5060-2000	IP21	AC/AC converter	IGBT Insulated Modules	690 V ac 50 Hz	460 V ac 60 Hz	2000	Frequency converter 50/60Hz for harbor applications	16000	A
APC-12-50	IP21	AC/AC converter + Three-Phase Diode Rectifiers	Press-pack Thyristor Press-pack Diode	400 V ac	12000 V dc	600	Testing room	600	B
AIS 0440	IP21	AC/AC converter	Press-pack Thyristor	400 V ac	400 V ac	2800	UPS	500	C
AI.....	IP21	DC/AC Inverter	IGBT Insulated Modules	1000 V dc	600 V ac	1500	Energy application	1500	D
ASU.....	IP21	DC/DC Converter.	IGBT Insulated Modules	600÷900 V dc	900÷1200 V dc	2000	Energy application	500	E
CCB-10-95	IP55	DC/DC Converter.	IGBT Insulated Modules	4000 V dc	95 V dc	10	On-Board railway auxiliary supply	500	F

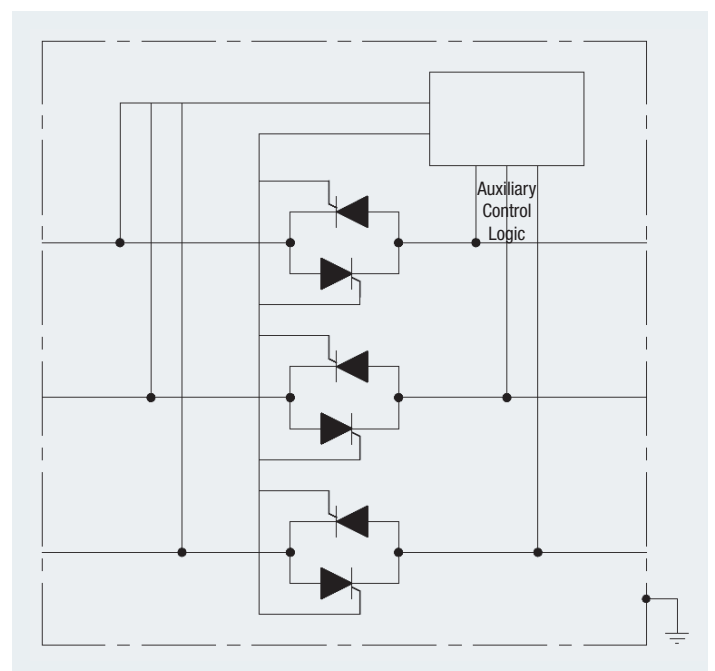
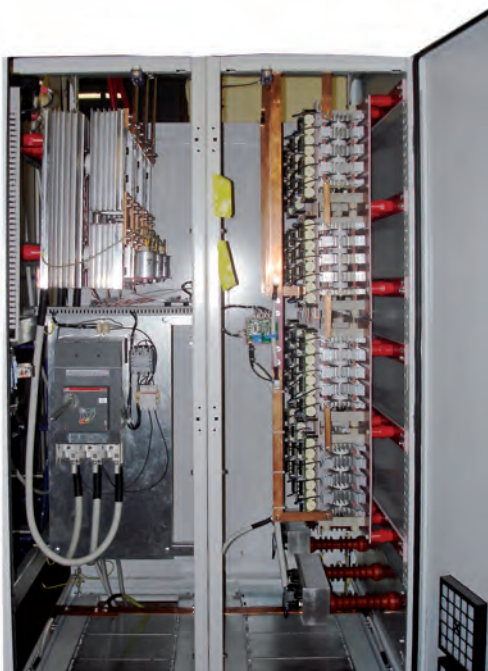

B APC-12-50 AC/AC converter + Three-Phase Diode Rectifiers for testing room application, 600 KVA

C AIS 0440 Schematics of AC/AC converter for UPS application , 2800 KVA

Frequency converter ACF5060 -2000 is a 50 - 60 Hz converter realized with four AC to DC front end converter to ensure low harmonic distortion rejected in input line; low harmonic distortion on generated output voltage and an intermediate voltage regulation converter to ensure output voltage immunity from wide input voltage variation angle. Input's and output's transformer and electromechanical switch are included in frequency converter to ensure a turn key solution. High efficiency, combined with an high overload withstand capability and high ambient temperature, characterize electrically the converter.

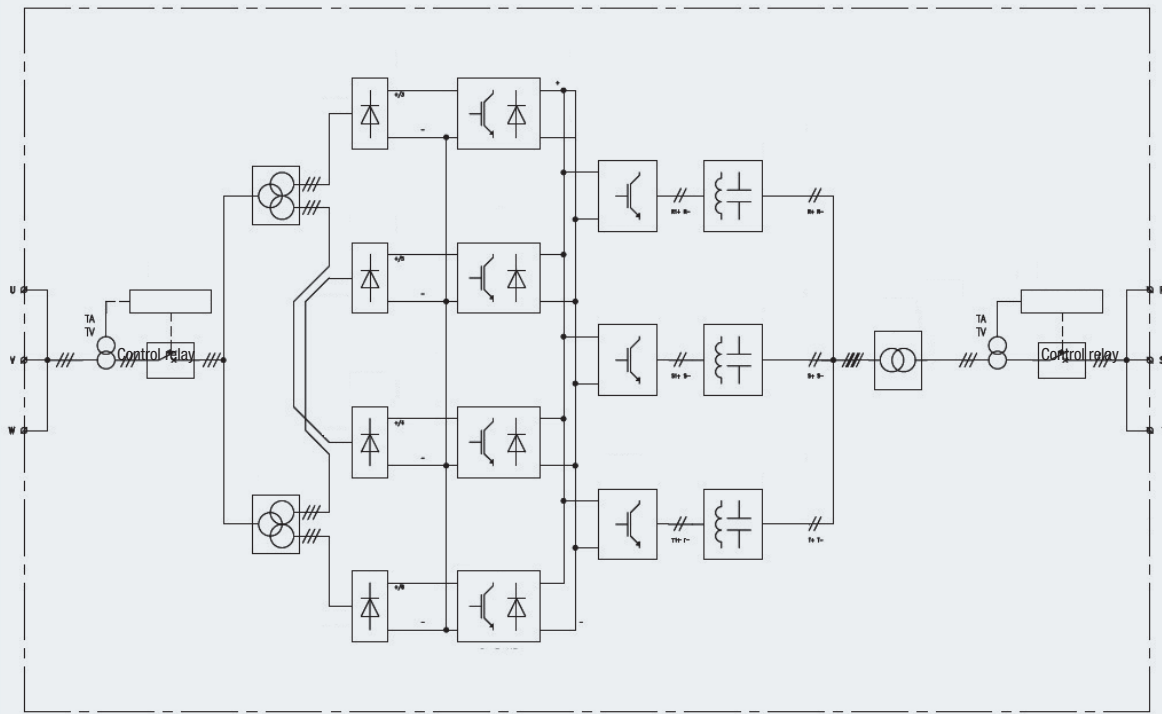

A ACF5060-2000 Frequency converter 50/60Hz for harbor application 2000 KVA

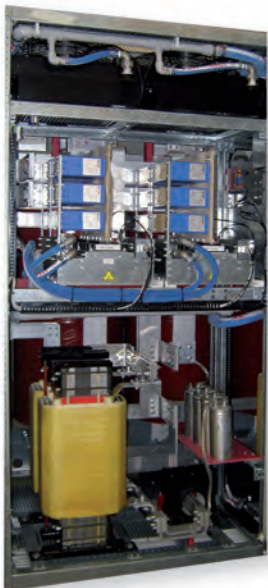

D DC/AC Inverter for energy application, 1200 KVA

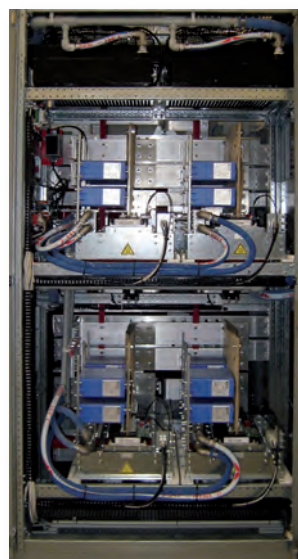

E Step-Up Converter, for energy application 2800 KVA



F CCB-10-95 DC/DC Converter for On-Board railway auxiliary supply, 10 KVA

Press-Pack High Power Semiconductor

High Power insulated modules

Accessories

Heatsinks and Cooling systems

Clamping systems

Power assemblies

Power converters and components for DC traction substations

Maintenance service

High Power Devices Testing Service

ISO 9001 certified testing laboratory for routine, type and reliability tests on high power semiconductors and characterization of bridge rectifier and power assemblies.

Testing equipment for high power semiconductor devices

Repetitive and non repetitive off-state and reverse voltage:
up to 10 KV; 400 mA; $T_j = -70^\circ\text{C} \div +190^\circ\text{C}$

On state voltage:
up to 10 V; 10KA; $T_j = +25^\circ\text{C} \div +190^\circ\text{C}$

Trigger characteristics:
 $T_j = -70^\circ\text{C} \div +190^\circ\text{C}$

Recovery Characteristics:
 $I = 10 \div 4000\text{ A}$; $di/dt = 0.4 \div 1000\text{ A}/\mu\text{s}$; $V_R = 10 \div 100\text{ V}$;
 $T_j = +25^\circ\text{C} \div +190^\circ\text{C}$

Fast switching thyristor tq characteristics:
 $I = 10 \div 4000\text{ A}$; $di/dt = 0.4 \div 300\text{ A}/\mu\text{s}$; $V_R = 10 \div 100\text{ V}$;
 $VD=200 \div 3000\text{ V}$; $dv/dt = 20 \div 2000\text{ V}/\mu\text{s}$;
 $T_j = +25^\circ\text{C} \div +190^\circ\text{C}$

GTO dynamic characteristics ITGQ, IRGM, t_d , t_r , t_s , t_f , t_{tail} , t_{tail} , E_{on} , E_{off} :
up to $I_T=3500\text{ A}$; $VD=4500\text{ V}$

IGBT static and dynamic characteristics

High temperature blocking life test

Leak test

Testing equipment for bridge rectifier and power assemblies

Three Phases High Voltage Supply:
2 KV \div 8 KV (15 KVA \div 3.5 KVA)

Six Phases High current supply:
10 KA (75 KVA)

Three Phases High Power Variable Voltage Supply:
0 \div 380 V (120 KVA)

DC High Power Variable Current Supply:
0 \div 4000A (40 KVA)

DC Variable Voltage Supply:
0 \div 6000V (1 A max)

Electric strength voltage test equipment:
up to 25 KV

High Power Semiconductor Failure Analysis Service

High power semiconductor (press-pack and insulated modules) failure analysis can be performed by POSEICO in order to evaluate the device failure mode in operation field. A large failure data base is available in POSEICO and can be used for a correct evaluation of the failure.

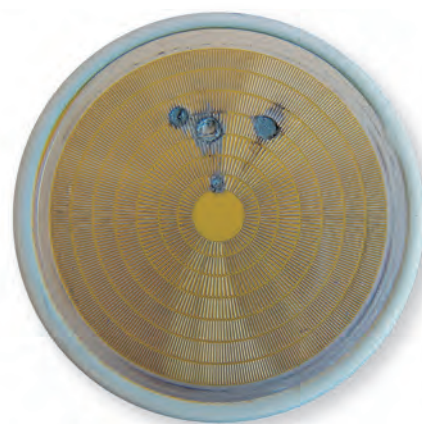
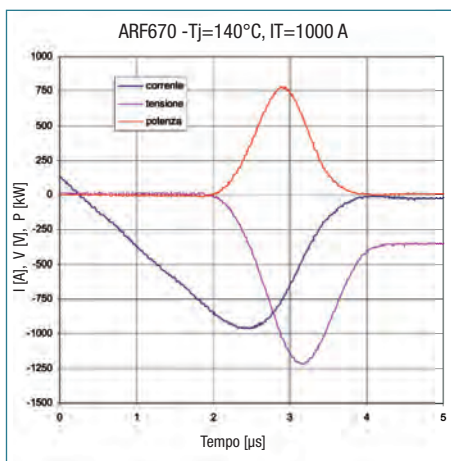

Replacement and Refurbishment for Traction and Auxiliary System Converter

POSEICO provide optimal solutions for replacement of key obsolete devices as RCT (reverse conducting thyristor) or small diameter GTO. POSEICO provides own experience and solutions for the complete refurbishment of power modules for traction or auxiliary system converters with different cooling technology: natural and forced air, deionized water cooling, oil and special fluid cooling as freon etc. In any case, POSEICO is able to provide advanced technical solutions, fast spare parts replacement, complete testing capability.

Year	Customer	Product	Description	Switching element	Reference
1997 - 2005	RENFE - Spain	INVERENFE1	Inverter leg module	Thyristor	3
2003	METRO ROMA - Italy	CCB-10-95	Auxiliary converter	IGBT Module	
	METRO MEXICO - Mexico	ASI-SG1200-01	Inverter leg module	Press-pack GTO	1
2004	FERROVIE NORD MILANO - Italy	ASI-ATF1047-01	Chopper module	Thyristor	2
	FERROVIE NORD MILANO - Italy	ASI-ATF820-01	Chopper module	Thyristor	2
	TRANSPOLE	APM2000GF	Power Insulated module	Press-pack GTO	
2005	FERROVIE NORD MILANO - Italy	ASI-ATA644-01	Chopper module	Asymmetrical thyristor	
	FERROVIE NORD MILANO - Italy	ASI-ARF463-01	Free-wheeling diode module	Thyristor	
2008	TRENITALIA - Italy	ADN001	No-return device	Diodes	
2011	TRENITALIA - Italy	RIP-35kW 380995	Auxiliary converter	IGBT Module	4
2013	TRANSPOLE	ASE020GDB	GTO Driver	–	

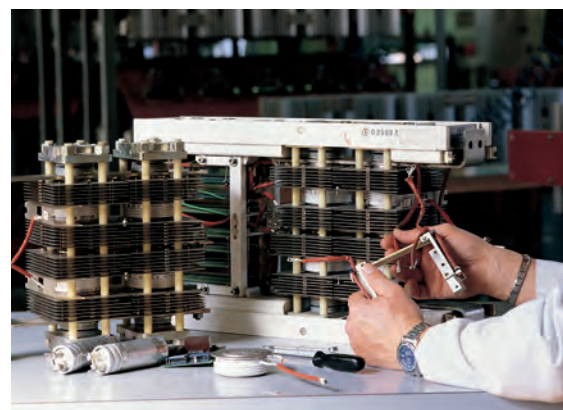

1. Metro Mexico / STC
2. LOCO E630 / FNM
3. LOCO 251 / Renfe
4. 35 kW Auxiliary Converter

High Power Assembly Maintenance Service

A complete service of high power assembly maintenance based on cleaning, failure diagnostic, devices replacement, stack repair and qualification, static and dynamic final testing, can be performed into the POSEICO maintenance service area.

Press-Pack High Power Semiconductor

High Power insulated modules

Accessories

Heatsinks and Cooling systems

Clamping systems

Power assemblies

Power converters and components for DC traction substations

Maintenance service

List of symbols

Vrrm	Repetitive peak reverse voltage
Vdrn	Repetitive peak off-state voltage
Irrm	Repetitive peak reverse current
Idrn	Repetitive peak off-state current
If(av)	Mean forward current
It(av)	Mean on-state current
Irms	RMS current
ifsm	Surge, non-repetitive, forward current
itsm	Surge, non-repetitive, on-state current
I ² t	Value for fusing coordination
Vf(to)	Forward threshold voltage
Vt(to)	On-state threshold voltage
rf	Forward slope resistance
rt	On-state slope resistance
Vgt	Gate trigger voltage
Igt	Gate trigger current
(di/dt) crit	Critical rate of rise of on-state current (repetitive)
(dv/dt) crit	Critical rate of rise of off-state voltage (repetitive)
Qrr	Reverse recovery charge
trr	Reverse recovery time
If	Current before recovery phenomena
di/dt	Slope of recovery current
Irr	Peak reverse recovery current
td	Delay time
tq	Circuit commutated turn-off time
tgt	Gate controlled turn-on time
tgq	Gate controlled turn-off time
Itcm	Controllable peak on-state current
Vdsp	Spike turn-off voltage
Tj	Virtual junction temperature
Rth(j-h)	Thermal resistance junction to heatsink
Rth(j-c)	Thermal resistance junction to case
Rth(c-h)	Thermal resistance case to heatsink
Rth(j-w)	Thermal resistance junction to water
Vins (rms)	Insulation voltage (r.m.s./50Hz/1 min)
F	Mounting force
Vfm	Forward voltage
Vdc link	Permanent DC voltage
Vces	Collector-emitter voltage
Ices	Collector cut-off current
Ic	Collector current
Icm	Repetitive peak collector current
Vces(sat)	Collector-emitter saturation voltage
Pc	Collector power dissipation
ton	Turn-on time
toff	Turn-off time
Vgeth	Gate-emitter threshold voltage
Vges	Gate-emitter peak voltage
Cies	Input capacitance
Tstg	Storage temperature Case temperaturei

Mounting recommendations

In the assembly of Power Semiconductors, in order to ensure effective cooling, good current conduction and reliability, it's important to observe some recommendations particularly regarding heatsink preparation and clamping system. The recommended procedure for assembling the components is as follows:

USING BAR CLAMPING SYSTEM

- clean the mounting area (a) of both heatsinks with "abrasive rubber" and after with alcohol.
- clean the mounting surfaces of the semiconductor with alcohol.
- apply a thin film of mounting grease(b) on both the mounting surfaces of the heatsinks.
- position the semiconductor between the two heatsinks and rotate it to spread the contact grease.

CAUTION: Each guide pin should be located in the center hole.

- pre-assemble the clamp housing if necessary.
- place the pre-assembled portion of the clamp through the heatsink and the semiconductor assembly.
- place over the upper heatsink the second part of the clamp, equipped with its spring system and hardware parts.
- tighten by "fingers" the screws and put in position all the assembly.

CAUTION: all the surfaces must be parallel before tightening.

- tighten the screws half a turn until the pressure indicating system shows that the required pressure has been achieved.

USING BOX CLAMPING SYSTEM

- clean the mounting area(a) of the heatsink with "abrasive rubber" and after with alcohol.
- clean the mounting surfaces of the semiconductor with alcohol.
- apply a thin film of mounting grease (b) on the surfaces of the device.
- position the box clamp over the device ensuring that the pins are correctly located.
- position the square steel plate over the central rod, putting bolts through the clamp whilst holding it firmly in place.
- screw the bolts "finger tight" then alternately, clockwise, half a turn until the box touches the heatsink all the way round.

CAUTION: Use anyway a torque wrench to apply the right clamping force.

(a) recommended machining tolerances over the device mounting area: flatness 30 micron, roughness 2 micron

(b) recommended mounting grease - CONTACTAL HPG

Note: before mounting into equipment the assembly must be tested by "leakage" test to verify the electrical integrity.

Maximum Allowable average current

In this catalogue the average current ratings are mostly specified for temperatures of: Th= 55°C, Tc=85°C at 180° sine wave.

For other temperatures, the current can be calculated using the following formulas applicable up to 400 Hz:

$$I_{(AV)} = \frac{-V_o + \sqrt{V_o^2 + 4K^2 rP}}{2K^2 r}$$

$$\text{where } P = \frac{T_j \text{ max} - T}{R_{th}}$$

$I_{(AV)}$	=	$I_{T(AV)}$ for thyristors, $I_{F(AV)}$ for diodes
V_o	=	$V_{T(TO)}$ for thyristors, $V_{F(TO)}$ for diodes
T	=	T_c or T_h
R_{th}	=	$R_{th(j-c)}$ or $R_{th(j-h)}$
r	=	r_T for thyristors, r_F for diodes
K	=	1 for direct current
K	=	($\pi/2$) for 180° sine wave
K	=	$\sqrt{3}$ for 120° rectangular wave
K	=	$\sqrt{6}$ for 160° rectangular wave

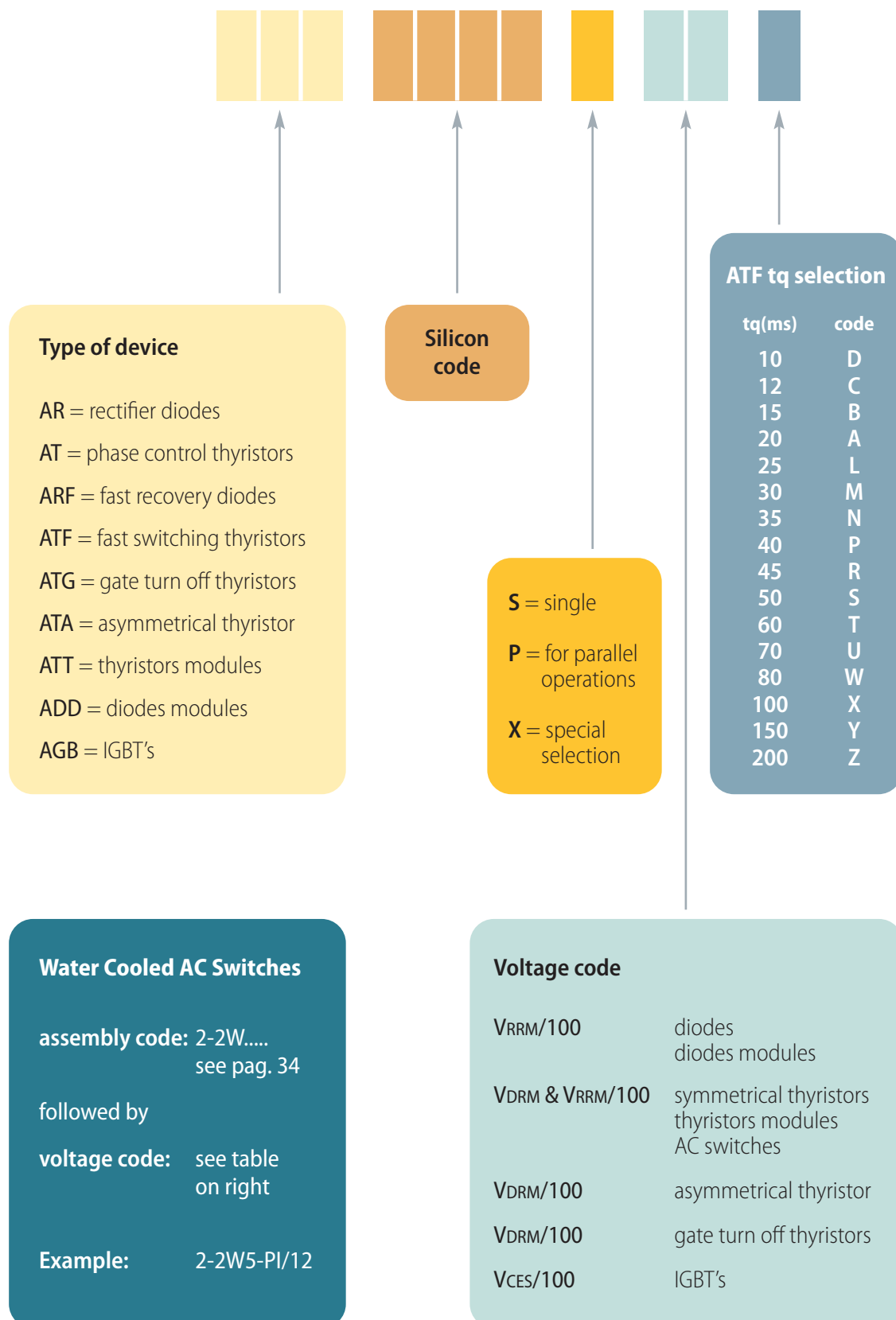

For special selections please contact the factory, agents or local distributors.

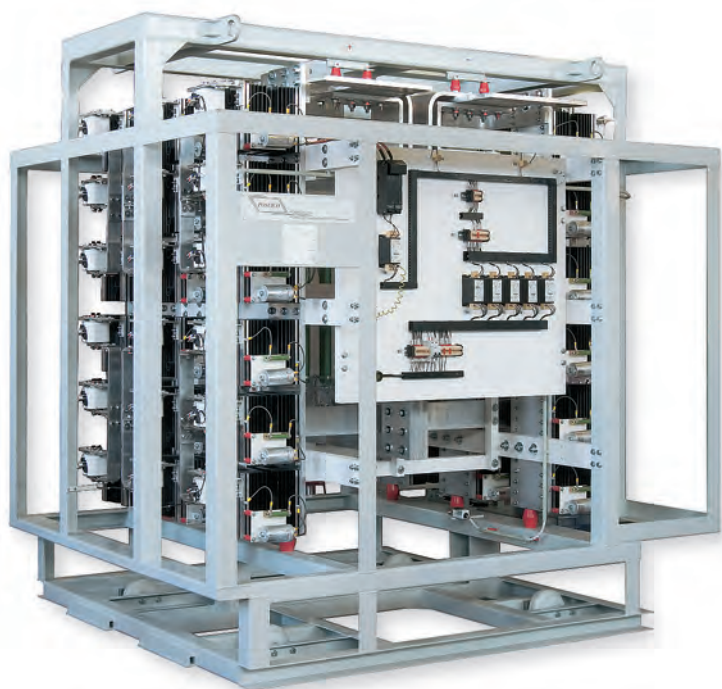

In the interest of product improvement POSEICO SPA reserves the right to change any data given in this shortform catalogue at any time without previous notice. Up-to-dated data available on www.poseico.com

Distributed by



Headquarters

Via Pillea, 42/44 - 16153 Genova, Italia
Phone +39.010.8599400 - Fax +39.010.8682006
e-mail: info@poseico.com

Poseico AZD1080S16 , AZD 1080S16,

Заказ Минск VIBER тел.+375 44 7584780 email minsk17@tut.by www.fotorele.net

радиодетали, электронные компоненты, каталог, описание, технические, характеристики, datasheet, параметры, маркировка, габариты, фото, анимация, видео

Branch Offices

Via Mille gatte, 11 - 16012 Busalla (Genova), Italia
Phone +39.010.8591650 - Fax +39.010.8591654
e-mail: info@poseico.com

230 Rue du 4 Août 1789
69100 Villeurbanne, France
Phone +33.(0)4.78850533 - Fax +33(0)4.78850533
e-mail: info@poseico.com

Parc Industrial Zarnesti - Str. Aleea Uzinei Nr. 1A (Hala 408)
505801 Zarnesti, Jud. Brasov, Romania
Phone +40.72999221 - Fax +40.368004098
e-mail: info@poseico.com

www.poseico.com