

**COMMONWEALTH Минск +375447584780 Viber email [minsk17@tut.by](mailto:minsk17@tut.by)**  
**[www.fotorele.net](http://www.fotorele.net) [www.tiristor.by](http://www.tiristor.by) tel.+375 29 758 47 80 МТС**



## **Электронные компоненты, радиодетали**

**[где и как купить в Минске?](#)**

Категория: **Вентилятор**

### **COMMONWEALTH FP-108K S1-B AC220/240V 50Hz 0.30A 44W 2wires Cooling Вентилятор**

Part Type	Cooling Вентилятор
Model	FP-108K S1-B
Brand	COMMONWEALTH
Size	220 mm x 220 mm x 60 mm
Length	220 mm
Width	220 mm
height	60 mm
voltage	220/240V
Current	0.30A
Power	44W

**[каталог, описание, технические, характеристики, datasheet, параметры, маркировка, габариты, фото,](#)**

**COMMONWEALTH**

**[купить, продажа](#)**

# COMMONWEALTH AC AXIAL FAN

## FP-108EXM

172x150x38mm



### DESIGN FEATURES

- \*BEARING SYSTEM: BALL BEARING
- \*IMPELLER: PLASTIC WITH FIBER GLASS FILLED UL 94V-0
- \*HOUSING: DIE CAST ALUMINUM PAINTED BLACK OR NATURAL COLOR
- \*MOTOR: SHADE POLE MOTOR
- \*PROTECTION: THERMAL PROTECTION & IMPEDANCE PROTECTION
- \*CONNECTING: WIRE LEADS & TERMINAL
- \*OTHER VOLTAGE: 24,48,100,380 V AC (50/60Hz) ARE AVAILABLE

### DIMENSIONS:MM

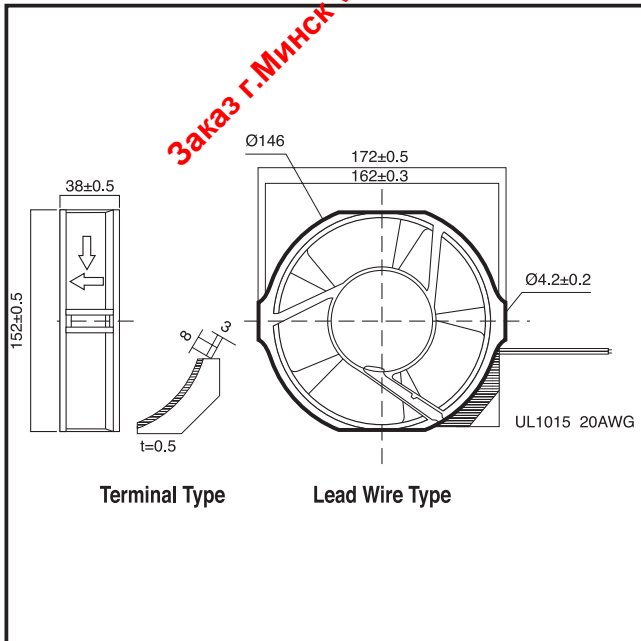

### PERFORMANCE

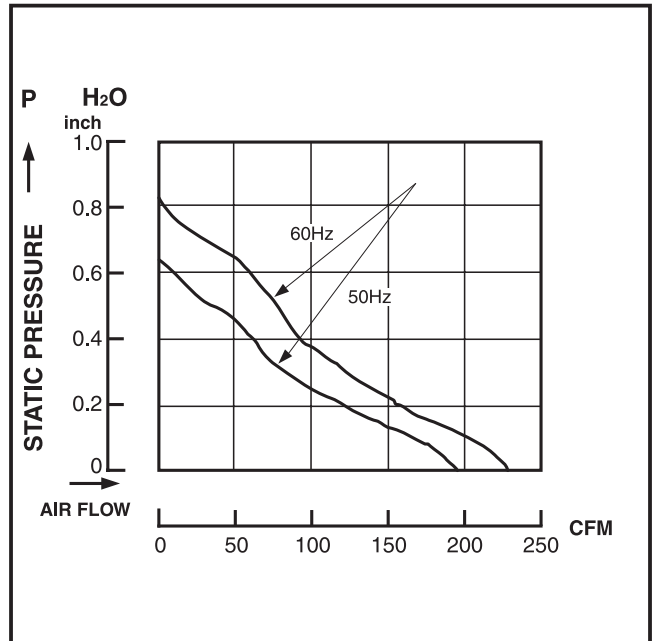

### SPECIFICATIONS

Specifications are subject to change without notice

MODEL NO.	VOLT (VAC)	FREQUENCY (HZ)	AIR (CFM)	VOLUME (M <sup>3</sup> /MIN)	CURRENT (A)	POWER (W)	SPEED (RPM)	STATIC PRESSURE (INCH-H <sub>2</sub> O)	NOISE (dBA)
FP-108EXM	110/120	50/60	205/230	5.80/6.50	0.40/0.40	30/28	2700/2900	0.75/0.60	49
FP-108EXM	220/240	50/60	205/230	5.80/6.50	0.28/0.23	38/35	2700/2900	0.75/0.60	49

# COMMONWEALTH AC AXIAL FAN

## FP-108-1

119x119x38mm VENUS

### DESIGN FEATURES

- \***BEARING SYSTEM:** SLEEVE BEARING & BALL BEARING
- \***IMPELLER:** PLASTIC WITH FIBER GLASS FILLED UL 94V-0
- \***HOUSING:** DIE CAST ALUMINUM PAINTED BLACK OR NATURAL COLOR OR PBT PLASTIC UL 94V-0
- \***MOTOR:** SHADED POLE, IMPEDANCE PROTECTED
- \***CONNECTING:** TERMINAL & WIRE LEADS
- \***SPEED:** S-U ULTRA TYPE
  - S-1 HIGH SPEED TYPE
  - S-2 MEDIUM SPEED TYPE
  - S-3 LOW SPEED TYPE
- \***OTHER VOLTAGE:** 24 ,48, 100, 380AC (50/60Hz) ARE AVAILABLE



### DIMENSIONS:MM

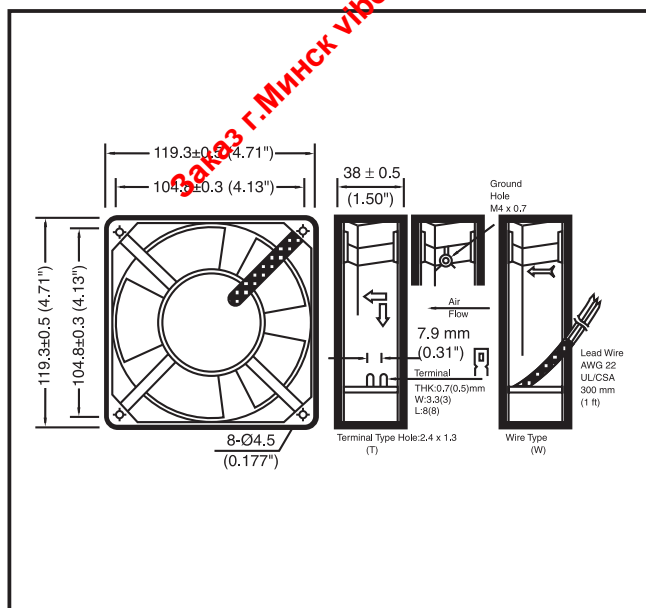

### PERFORMANCE

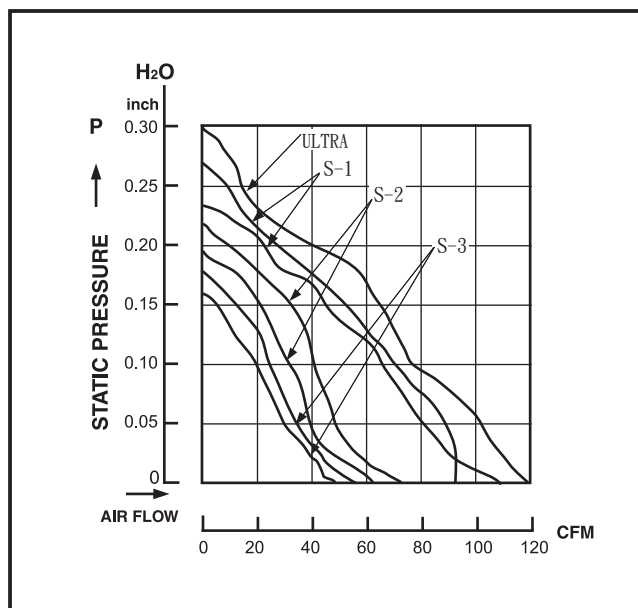

### SPECIFICATIONS

Specifications are subject to change without notice

MODEL NO.	VOLT (VAC)	FREQUENCY (HZ)	AIR (CFM)	VOLUME (M <sup>3</sup> /MIN)	CURRENT (A)	POWER (W)	SPEED (RPM)	STATIC PRESSURE (INCH-H <sub>2</sub> O)	NOISE (dBA)
<b>**NEW</b>	110/120	50/60	112/120	3.18/3.40	0.25/0.19	18/19	2700/3000	0.27/0.30	40/45
FP-108-1 (S-ULTRA)	220/240	50/60	112/120	3.18/3.40	0.14/0.12	18/19	2700/3000	0.27/0.30	40/45
FP-108-1 (S-1)	110/120	50/60	80/105	2.30/3.00	0.24/0.18	18/17	2700/3000	0.23/0.28	42/47
<b>FP-108-1 (S-1)</b>	<b>220/240</b>	<b>50/60</b>	<b>80/105</b>	<b>2.30/3.00</b>	<b>0.13/0.11</b>	<b>18/17</b>	<b>2700/3000</b>	<b>0.23/0.28</b>	<b>42/47</b>
FP-108-1 (S-2)	110/120	50/60	63/71	1.65/1.85	0.13/0.12	11/10	2200/2500	0.19/0.21	37/39
FP-108-1 (S-2)	220/240	50/60	63/71	1.65/1.85	0.11/0.09	11/10	2200/2500	0.19/0.21	37/39
FP-108-1 (S-3)	110/120	50/60	54/52	1.50/1.40	0.11/0.10	9/8	1800/2000	0.16/0.15	30/34
FP-108-1 (S-3)	220/240	50/60	54/52	1.50/1.40	0.08/0.06	9/8	1800/2000	0.16/0.15	30/34

# COMMONWEALTH AC AXIAL FAN

## FP-108EX

172x150x51mm MARS

## FP-108E

172Øx51mm



### DESIGN FEATURES

- \*BEARING SYSTEM: SLEEVE BEARING & BALL BEARING
- \*IMPELLER: PLASTIC WITH FIBER GLASS FILLED UL 94V-0
- \*HOUSING: DIE CAST ALUMINUM PAINTED BLACK OR NATURAL COLOR
- \*MOTOR: SHADED POLE, IMPEDANCE PROTECTED
- \*CONNECTING: TERMINAL & WIRE LEADS
- \*SPEED: S-1 HIGH SPEED TYPE  
S-2 MEDIUM SPEED TYPE  
S-3 LOW SPEED TYPE
- \*OTHER VOLTAGE: 24 ,48, 100, 380AC (50/60Hz) ALL AVAILABLE

### DIMENSIONS:MM

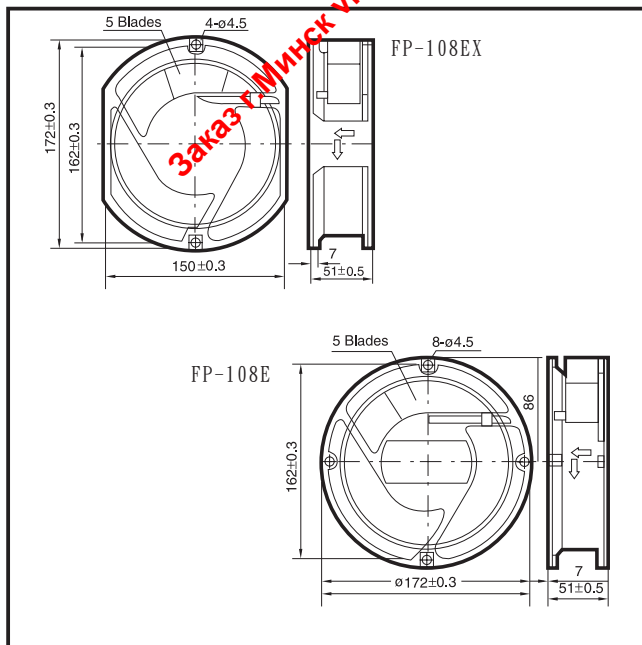

### PERFORMANCE

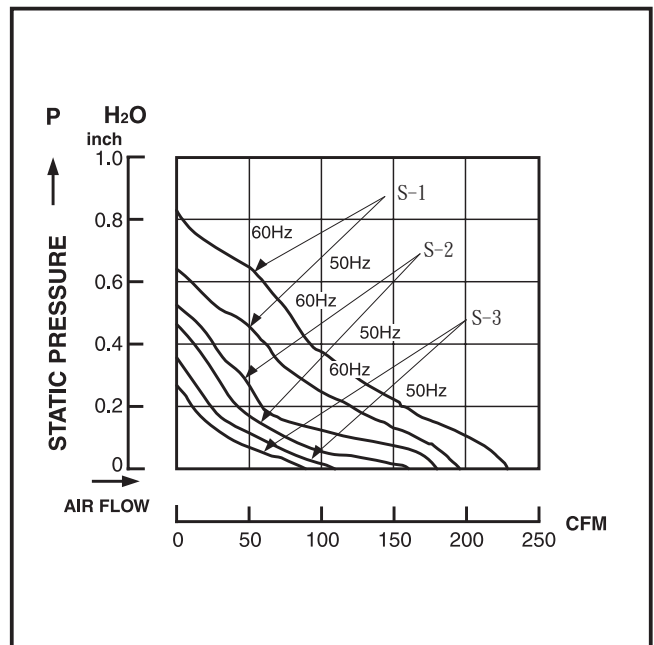

### SPECIFICATIONS

Specifications are subject to change without notice

MODEL NO.	VOLT (VAC)	FREQUENCY (HZ)	AIR (CFM)	VOLUME (M <sup>3</sup> /MIN)	CURRENT (A)	POWER (W)	SPEED (RPM)	STATIC PRESSURE (INCH-H <sub>2</sub> O)	NOISE (dBA)
FP-108EX (S-1)	110/120	50/60	190/235	5.40/6.6	0.50/0.45	38/35	2800/3100	0.63/0.79	50/45
FP-108E (S-1)									
FP-108EX (S-1)	220/240	50/60	190/235	5.40/6.6	0.23/0.21	32/31	2800/3100	0.63/0.79	50/45
FP-108E (S-1)									
FP-108EX (S-2)	110/120	50/60	165/170	4.70/4.8	0.42/0.37	29/30	2300/2400	0.51/0.55	38/33
FP-108E (S-2)									
FP-108EX (S-2)	220/240	50/60	165/170	4.70/4.8	0.18/0.17	27/29	2300/2400	0.51/0.55	38/33
FP-108E (S-2)									
FP-108EX (S-3)	110/120	50/60	110/106	3.10/3.0	0.35/0.33	22/21	2100/1900	0.40/0.31	33/30
FP-108E (S-3)									
FP-108EX (S-3)	220/240	50/60	110/106	3.10/3.0	0.15/0.12	22/19	1900/1800	0.40/0.31	33/30
FP-108E (S-3)									