

Вентилятор sanyo denki san ace , Минск тел. +375447584780

www.fotorele.net www.tiristor.by радиодетали, электронные компоненты

email minsk17@tut.by tel.+375 29 758 47 80 МТС

каталог, описание, технические, характеристики, datasheet, параметры, маркировка, габариты, фото

QR код



9GT type

Wide Temperature Range Fan DC

These fans achieve an operating temperature range of -40°C to +85°C. They operate in a wide temperature range, serving in various applications where conventional fans could not be used. They are suitable for refrigerators and freezers, lighting devices, communications devices, PV inverters, and rapid EV charging stations.

40mm sq. to 120mm sq.
⇒pp. 359 to 370



9AD type

ACDC Fan AC

This fan operates by internally converting AC power into DC power. It provides the superior performance of a DC fan with the flexibility of AC input.

92x92x38mm
⇒pp. 413 to 416

120x120x38mm
⇒pp. 417 to 420



9RF type

Reversible Flow Fan DC

Multiple fans are usually used to blow air in both directions to ventilate houses, and to cool drink vending machines, and food display cases. With reversible flow fans, the wind direction can be switched so fewer fans are required.

φ136x28mm
⇒pp. 243 to 244



Options (unit: mm)

Finger Guards

Model : 109-719 Surface treatment : Nickel-chrome plating (silver) Color

Model : 109-719H Surface treatment : Cation electropainting (black) Color

Inlet side, Outlet side

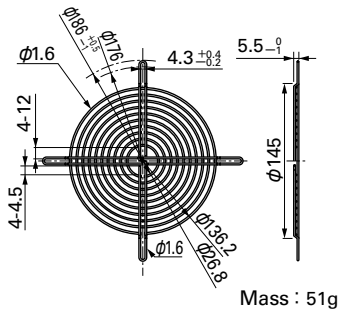

Inlet side, Outlet side

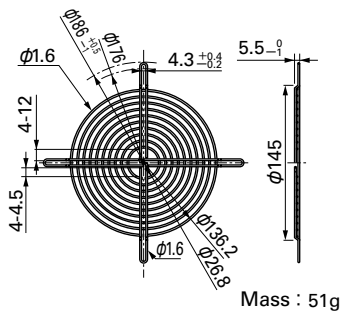

Airflow - Static Pressure Characteristics

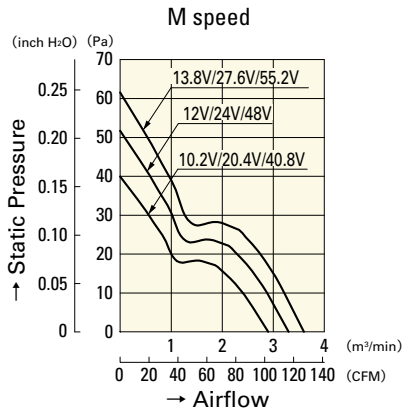
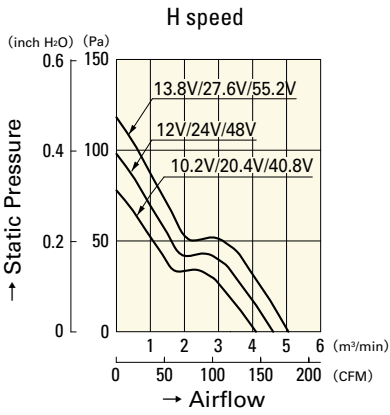

109L1412H101

109L1424H101

109L1448H101

109L1412M101

109L1424M101

109L1448M101

DC

Long Life Fan 140mm

140mm sq.

San Ace 140L



Model no. 9LB1424B501, 9LB1448F501 are not certified.

General Specifications

- Material Frame: Aluminum,
Impeller: Plastics (Flammability: UL94V-1)
- Expected Life Refer to specifications (L10:Survival rate: 90% at 60°C ,
rated voltage, and continuously run in a free air state)
- Lead Wire ⊕red ⊖black or blue (Sensor) yellow
- Storage Temperature -30°C to +70°C (Non-condensing)

140×140×51mm (Mass : 610g) **9LB type**

Specifications

The following nos. **have pulse sensors.**

Model No.	Rated Voltage [V]	Operating Voltage Range [V]	Rated Current [A]	Rated Input [W]	Rated Speed [min ⁻¹]	Max. Airflow [m ³ /min] [CFM]	Max. Static Pressure [Pa] [inchH ₂ O]	SPL [dB(A)]	Operating Temperature [°C]	Expected Life [h]
9LB1412S501	12	10.2 to 13.8	2.7	32.4	4,200	8.1 286.2	240 0.96	57	- 20 to + 70	60,000/60°C
9LB1412H501			1.25	15.0	3,100	5.9 208.5	130 0.52	49		100,000/60°C
9LB1412M501			0.46	5.52	2,050	3.9 138	63 0.25	39		100,000/60°C
9LB1424S501	24	20.4 to 27.6	1.38	33.12	4,200	8.1 286.2	240 0.96	57		60,000/60°C
9LB1424B501			0.97	23.3	3,700	7.1 251	186 0.75	55		100,000/60°C
9LB1424H501			0.60	14.4	3,100	5.9 208.5	130 0.52	49		100,000/60°C
9LB1424M501			0.22	5.28	2,050	3.9 138	63 0.25	39		100,000/60°C
9LB1448S501	48	40.8 to 55.2	0.71	34.08	4,200	8.1 286.2	240 0.96	57		60,000/60°C
9LB1448H501			0.27	12.96	3,100	5.9 208.5	130 0.52	49		100,000/60°C
9LB1448F501			0.18	8.6	2,550	4.8 169	91 0.37	44		100,000/60°C
9LB1448M501			0.12	5.76	2,050	3.9 138	63 0.25	39	100,000/60°C	

Other sensor specifications are available as options. Please refer to the index (p. 509).

Dimensions (unit: mm)

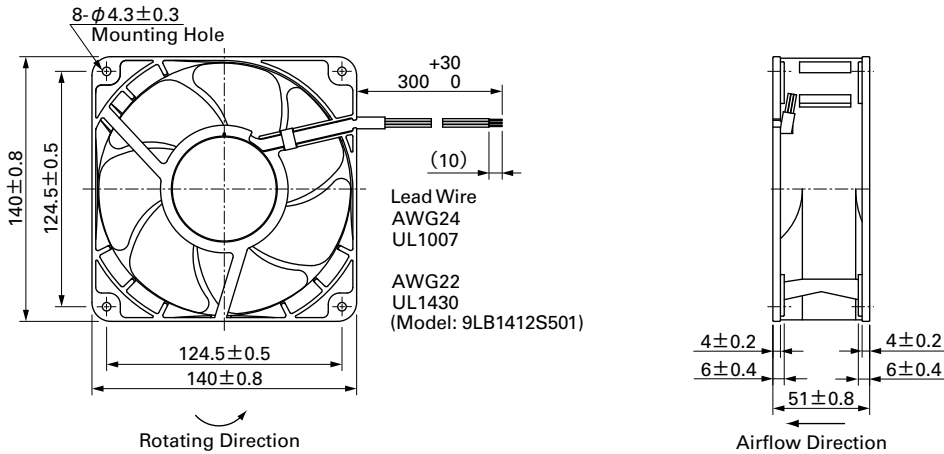

Reference Dimensions of Mounting Holes and Vent Opening (unit: mm)

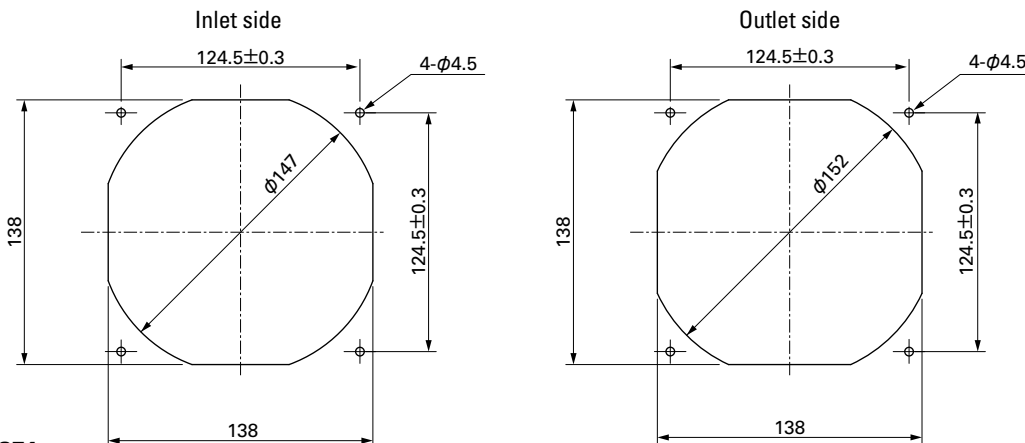

Options (unit: mm)

Finger Guards

Model : 109-719 Surface treatment : Nickel-chrome plating (silver) Color

Model : 109-719H Surface treatment : Cation electropainting (black) Color

Inlet side, Outlet side

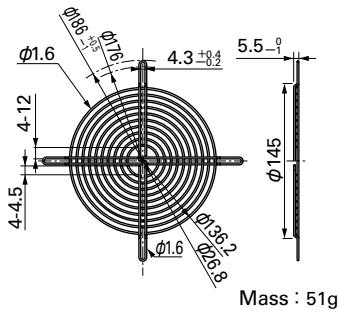

Inlet side, Outlet side

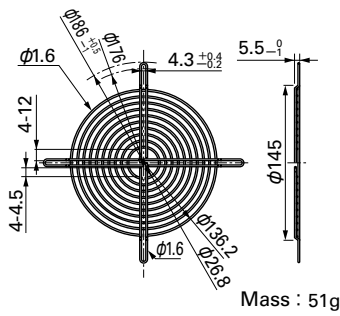

Airflow - Static Pressure Characteristics

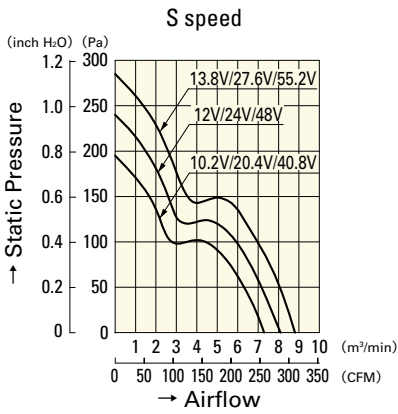

- 9LB1412S501**
- 9LB1424S501**
- 9LB1448S501**

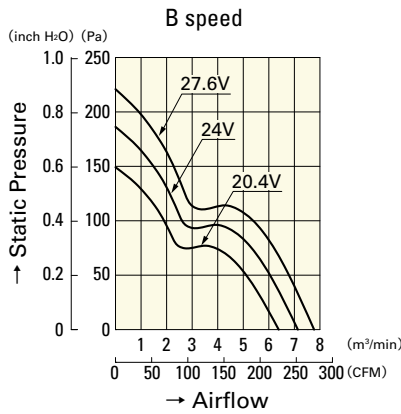

- 9LB1424B501**

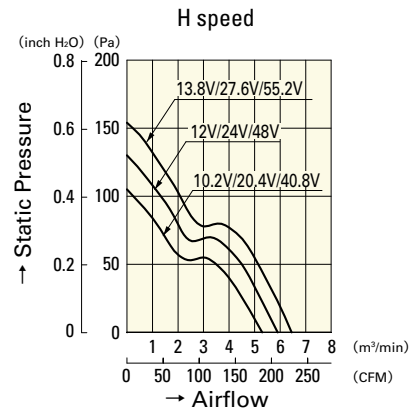

- 9LB1412H501**
- 9LB1424H501**
- 9LB1448H501**

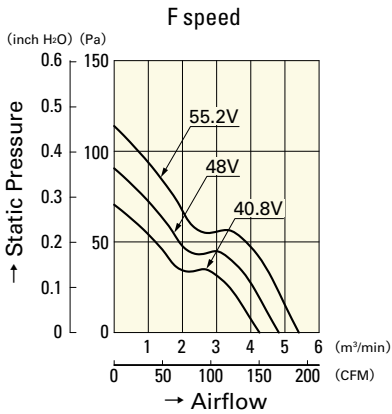

- 9LB1448F501**

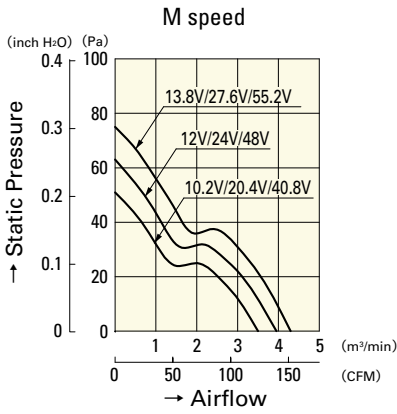

- 9LB1412M501**
- 9LB1424M501**
- 9LB1448M501**

DC
Long Life Fan 140mm

φ 172mm

San Ace 172L



General Specifications

- Material Frame: Aluminum,
Impeller: Plastics (Flammability: UL94V-1)
- Expected Life Refer to specifications (L10:Survival rate: 90% at 60°C ,
rated voltage, and continuously run in a free air state)
- Lead Wire ⊕red ⊖black or blue (Sensor) yellow
- Storage Temperature -30°C to +70°C (Non-condensing)

φ 172mm × 150mm × 51mm (Mass : 760g) **9L type** **Sidecut type**

Specifications

The following nos. have pulse sensors.

Model No.	Rated Voltage [V]	Operating Voltage Range [V]	Rated Current [A]	Rated Input [W]	Rated Speed [min ⁻¹]	Max. Airflow [m ³ /min] [CFM]	Max. Static Pressure [Pa] [inchH ₂ O]	SPL [dB(A)]	Operating Temperature [°C]	Expected Life [h]
109L5712H501	12	10.2 to 13.8	1.2	14.4	3,050	6.4 226	137.2 0.551	52	- 20 to + 70	100,000/60°C
109L5712M501			0.48	5.76	2,000	4.2 148	67.6 0.271	41		
109L5724H501	24	20.4 to 27.6	0.58	13.92	3,050	6.4 226	137.2 0.551	52		
109L5724M501			0.2	4.80	2,000	4.2 148	67.6 0.271	41		
109L5748H501	48	40.8 to 55.2	0.28	13.44	3,050	6.4 226	137.2 0.551	52		
109L5748M501			0.11	5.28	2,000	4.2 148	67.6 0.271	41		

Other sensor specifications are available as options. Please refer to the index (p. 496).

Dimensions (unit: mm)

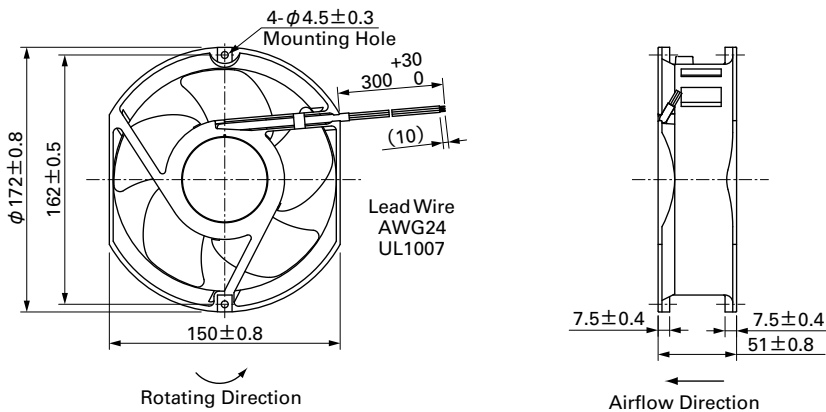

Reference Dimensions of Mounting Holes and Vent Opening (unit: mm)

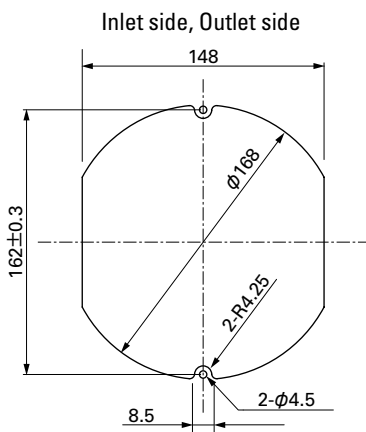

Options (unit: mm)

Finger Guards

Model : 109-319E Surface treatment : Nickel-chrome plating (silver) Color : 109-319H Cation electropainting (black)

Model : 109-320 Surface treatment : Nickel-chrome plating (silver) Color

Inlet side, Outlet side

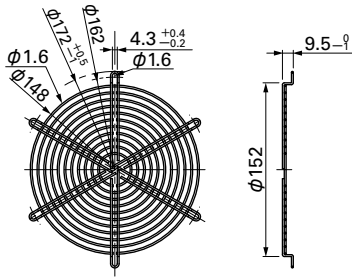

Mass : 69g

Outlet side

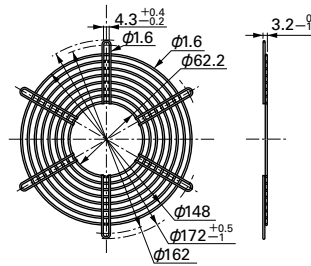

Mass : 53g

Airflow - Static Pressure Characteristics

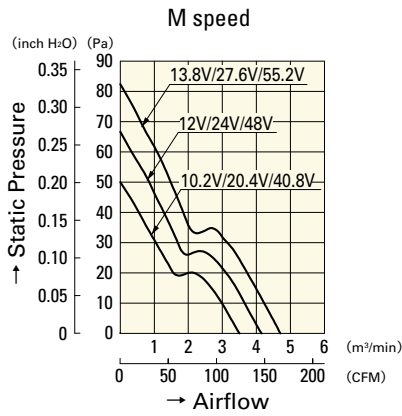
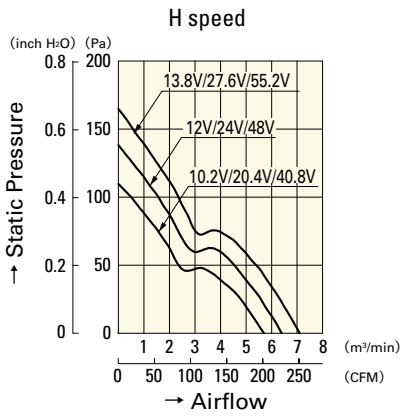

109L5712H501

109L5724H501

109L5748H501

109L5712M501

109L5724M501

109L5748M501

φ 172mm

San Ace 172L



General Specifications

- Material Frame: Aluminum,
Impeller: Plastics (Flammability: UL94V-1)
- Expected Life Refer to specifications (L10:Survival rate: 90% at 60°C ,
rated voltage, and continuously run in a free air state)
- Lead Wire ⊕red ⊖black or blue (Sensor) yellow
- Storage Temperature -30°C to +70°C (Non-condensing)

φ 172mm × 51mm (Mass : 780g) **9L type** **Round type**

Specifications

The following nos. **have pulse sensors.**

Model No.	Rated Voltage [V]	Operating Voltage Range [V]	Rated Current [A]	Rated Input [W]	Rated Speed [min ⁻¹]	Max. Airflow [m ³ /min] [CFM]	Max. Static Pressure [Pa] [inchH ₂ O]	SPL [dB(A)]	Operating Temperature [°C]	Expected Life [h]
109L1712H501	12	10.2 to 13.8	1.2	14.4	3,050	6.4 226	137.2 0.551	47	- 20 to + 70	100,000/60°C
109L1712M501			0.48	5.76	2,000	4.2 148	67.6 0.271	36		
109L1724H501	24	20.4 to 27.6	0.58	13.92	3,050	6.4 226	137.2 0.551	47		
109L1724M501			0.2	4.80	2,000	4.2 148	67.6 0.271	36		
109L1748H501	48	40.8 to 55.2	0.28	13.44	3,050	6.4 226	137.2 0.551	47		
109L1748M501			0.11	5.28	2,000	4.2 148	67.6 0.271	36		

Other sensor specifications are available as options. Please refer to the index (p. 496).

Dimensions (unit: mm)

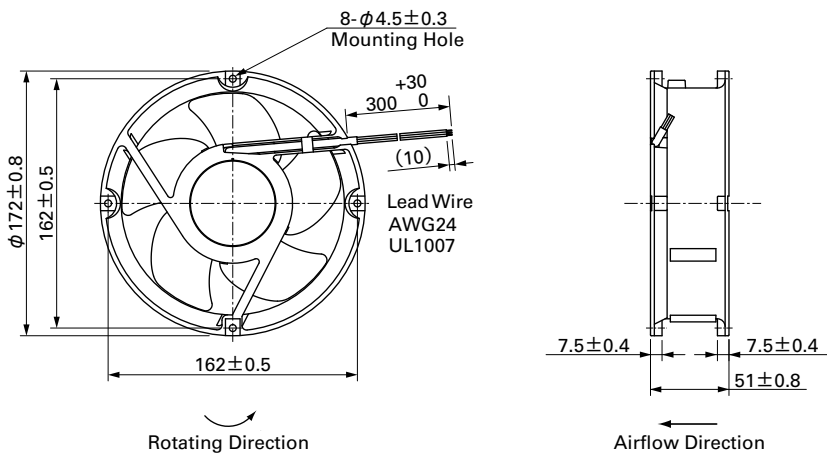

Reference Dimensions of Mounting Holes and Vent Opening (unit: mm)

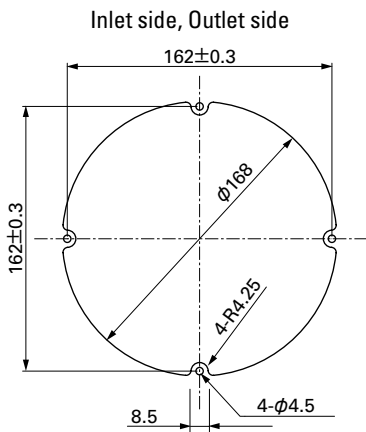

Options (unit: mm)

Finger Guards

Model : 109-1066 Surface treatment : Nickel-chrome plating (silver) Color

Model : 109-1068 Surface treatment : Nickel-chrome plating (silver) Color

Inlet side, Outlet side

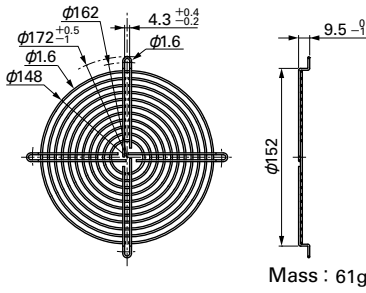

Outlet side

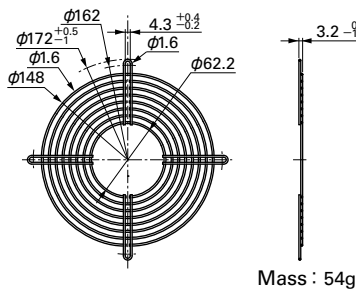

Model : 109-319E Surface treatment : Nickel-chrome plating (silver) Color
: 109-319H : Cation electropainting (black)

Model : 109-320 Surface treatment : Nickel-chrome plating (silver) Color

Inlet side, Outlet side

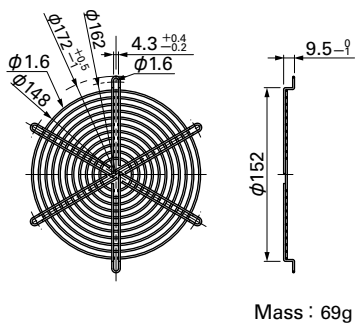

Outlet side

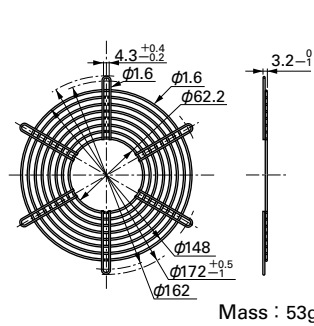

Airflow - Static Pressure Characteristics

H speed

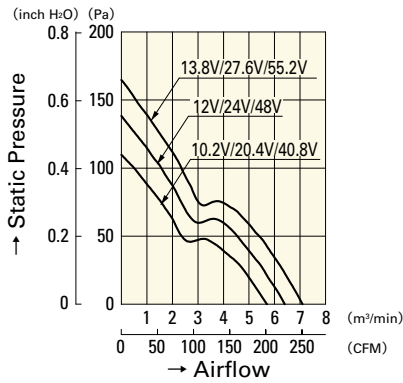

M speed

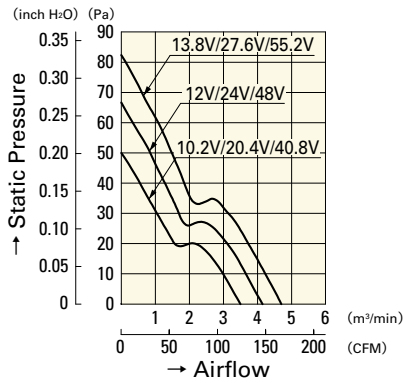

109L1712H501

109L1724H501

109L1748H501

109L1712M501

109L1724M501

109L1748M501

DC
Long Life Fan 172mm

Wide Temperature Range Fan

These fans can be used in a wide temperature range from -40°C to $+85^{\circ}\text{C}$.

Domain Diagram

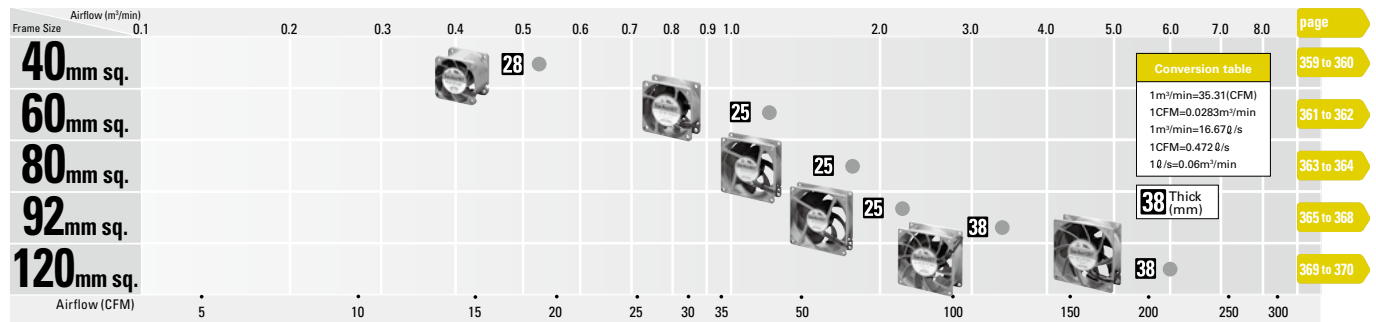

Model Numbering System

Not every combination of the following codes or characters is available. Contact us for an available combination.

9GT	04	12	P	3	J	001
Type name / frame material 9GT / Plastics	Frame size 04 : 40×40mm 06 : 60×60mm 08 : 80×80mm 09 : 92×92mm 12 : 120×120mm	Voltage 12 : 12V 24 : 24V	PWM control function	Frame thickness 1 : 38mm thick 3 : 28mm thick 4 : 25mm thick	Speed code	Individual customer's spec

How to Read Specifications

DC Fan											DC	
Model No.	① Rated Voltage [V]	② Operating Voltage Range [V]	③ Rated Current [A]	④ Rated Input [W]	⑤ Rated Speed [min ⁻¹]	⑥ Max. Airflow [m ³ /min] [CFM]		⑦ Max. Static Pressure [Pa] [inchH ₂ O]		⑧ SPL [dB(A)]	⑨ Operating Temperature [°C]	⑩ Expected Life [h]
9GA0412G7001	12	7 to 13.8	0.17	2.04	13,100	0.36	12.7	192	0.77	42	-20 to +70	40,000/60°C (70,000/40°C)

- ① Rated Voltage This is the necessary voltage to drive the fan. 12VDC, 24VDC and 48VDC are available.
- ② Operating Voltage Range... The voltage range over which fan operation is guaranteed
- ③ Rated Current The current value during the fan's rated operation without load
- ④ Rated Input The input value during the fan's rated operation without load
- ⑤ Rated Speed The rotating speed during the fan's rated operation without load
- ⑥ Max. Airflow The maximum air volume that the fan can output during rated operation (according to the company's dual-chamber device).
The volume of air generated by the fan in a given time period
- ⑦ Max. Static Pressure The maximum static pressure value that the fan can output during rated operation (according to the company's dual-chamber device). The static pressure is the fan's force to propel air by overcoming the resistance of the device that uses the fan when it propels air.
- ⑧ SPL..... "SPL" is Sound Pressure Level. The noise level during the fan's rated operation.
Please refer to the technical material section for the method used to measure the noise level.
- ⑨ Operating Temperature The temperature range over which fan operation is guaranteed (Non- condensing)
- ⑩ Expected Life The fan's expected operating life when the fan operates continuously at the rated voltage at a temperature of 60°C and at relative humidity of 90%. Expected life at 40°C ambient is just reference value.
Please refer to the technical material section for the expected operating life.

DC Fan Common Specifications

Material Frame,Impeller:Plastics / Frame:Aluminum,Impeller:Plastics

* For details, refer to the appropriate page.

Expected LifeVaries for each model (L10:Survival rate:90% at 60°C ,rated voltage, and continuously run in a free air state)

* Splash proof fan: Varies for each model (Indoor, L10:Survival rate:90% at 60°C ,rated voltage, and continuously run in a free air state)

Motor ProtectionBurnout protection at locked rotor condition and Reverse polarity protection

Dielectric StrengthAC50/60Hz 500VAC 1minute(between lead conductor and frame)

Insulation Resistance10M Ω or more at 500VDC megger (between lead conductor and frame)

Sound Pressure Level(SPL) ..Expressed as the value at 1m from air inlet side

Lead WireFor details, refer to the appropriate page.

Overheating protection function

Protection Functions:

If the fan blades are restricted, an overcurrent occurs and leads to a rise in the fan coil temperature. This can result in reduced performance, damage, or a fire. To prevent this from occurring, SANYO DENKI's fans incorporate an overheating protection function. Refer to the catalog for the types of protection functions.

Burnout protection function at locked rotor condition

- Current cutoff system

If the fan blades are restricted, the coil current is cut off at regular cycles to prevent overheating of the coil. When the hindrance is removed, the fan restarts automatically.

Reverse polarity protection function

No problem about fan even if positive & negative lead are connected in reverse.

However, when wiring fans with sensors or PWM speed control function, connecting positive and negative leads in reverse may damage the fans.

40 mm sq.

San Ace 40T

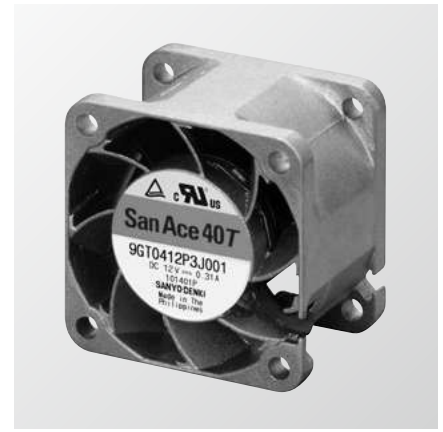

General Specifications

- Material Frame: Aluminum, Impeller: Plastics (Flammability: UL94V-1)
- Expected Life Refer to specifications (L10: Survival rate: 90% at 85°C, rated voltage, and continuously run in a free air state)
- Lead Wire ⊕ red ⊖ black (Sensor) yellow (Control) brown
- Storage Temperature -40°C to +85°C (Non-condensing)

40×40×28mm (Mass : 55g) **9GT** type

Specifications

The following nos. have PWM controls and pulse sensors.

Model No.	Rated Voltage [V]	Operating Voltage Range [V]	PWM duty cycle ^{Note1)} [%]	Rated Current [A]	Rated Input [W]	Rated Speed [min ⁻¹]	Max. Airflow [m ³ /min] [CFM]	Max. Static Pressure [Pa] [inchH ₂ O]	SPL [dB(A)]	Operating Temperature [°C]	Expected Life [h]
9GT0412P3J001	12	10.2 to 13.8	100	0.31	3.72	11,700	0.52 18.4	206 0.827	48	-40 to +85	40,000/85°C
			30	0.08	0.96	4,100	0.18 6.36	25.2 0.100	21		
9GT0424P3J001	24	20.4 to 27.6	100	0.15	3.60	11,700	0.52 18.4	206 0.827	48		
			30	0.05	1.20	4,100	0.18 6.36	25.2 0.100	21		

Note : Fan does not rotate when PWM duty cycle is 0%.

※PWM Frequency : 25kHz

Other sensor specifications are available as options. Please refer to the index (p. 506).

Dimensions (unit: mm)

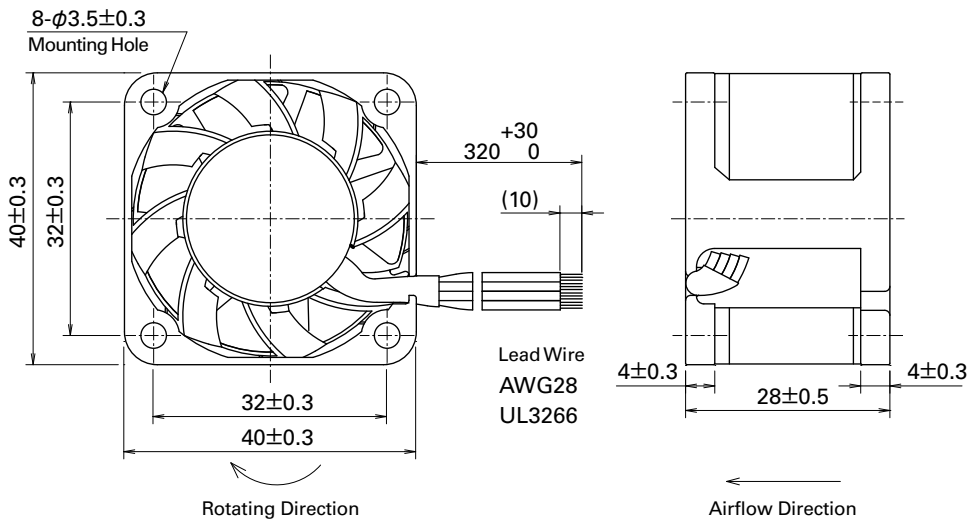

Reference Dimensions of Mounting Holes and Vent Opening (unit: mm)

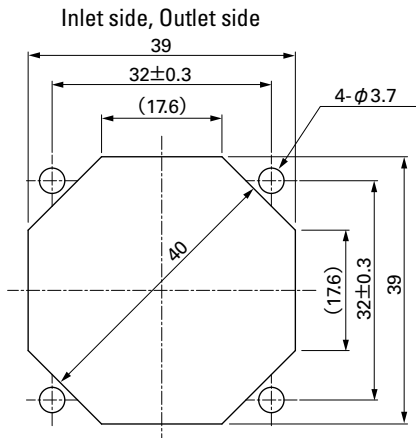

Options (unit: mm)

Finger Guards

Model : 109-059 Surface treatment : Nickel-chrome plating (silver)
 : 109-059H : Cation electropainting (black)

Color

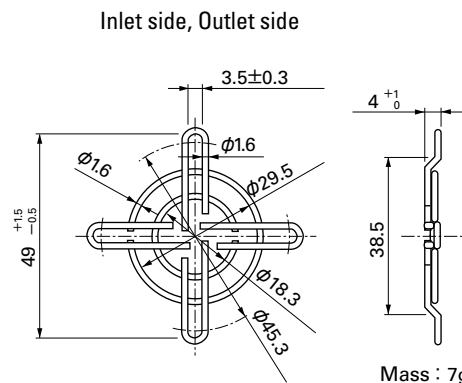

Mass : 7g

Airflow - Static Pressure Characteristics

PWM Duty Cycle

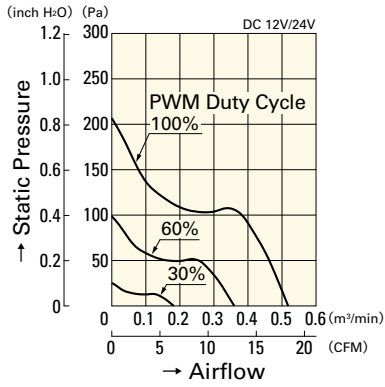

9GT0412P3J001

9GT0424P3J001

Operating Voltage Range

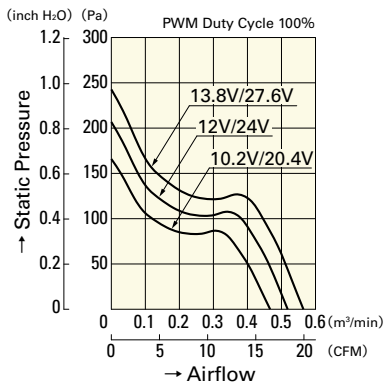

9GT0412P3J001

9GT0424P3J001

PWM Duty - Speed Characteristics Example

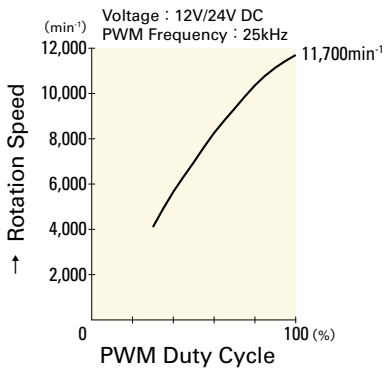

9GT0412P3J001

9GT0424P3J001

DC

Wide Temperature Range Fan 40mm

60mm sq.

San Ace 60T



General Specifications

- Material Frame: Aluminum, Impeller: Plastics (Flammability: UL94V-1)
- Expected Life Refer to specifications (L10:Survival rate:90% at 85°C ,
rated voltage, and continuously run in a free air state)
- Lead Wire ⊕red ⊖black (Sensor) yellow (Control) brown
- Storage Temperature -40°C to +85°C (Non-condensing)

60×60×25mm (Mass : 100g) **9GT** type

Specifications

The following nos. **have PWM controls and pulse sensors.**

Model No.	Rated Voltage [V]	Operating Voltage Range [V]	PWM duty cycle ^{※1)} [%]	Rated Current [A]	Rated Input [W]	Rated Speed [min ⁻¹]	Max. Airflow [m ³ /min] [CFM]	Max. Static Pressure [Pa] [InchH ₂ O]	SPL [dB(A)]	Operating Temperature [°C]	Expected Life [h]
9GT0612P4G001	12	10.2 to 13.8	100	0.56	6.72	10,000	1.26 44.5	243 0.97	52	-40 to +85	40,000/85°C
			30	0.11	1.32	4,100	0.52 18.3	42.8 0.17	25		
9GT0624P4G001	24	20.4 to 27.6	100	0.28	6.72	10,000	1.26 44.5	243 0.97	52		
			30	0.06	1.44	4,100	0.52 18.3	42.8 0.17	25		

Note : Fan does not rotate when PWM duty cycle is 0%.

※PWM Frequency : 25kHz

Other sensor specifications are available as options. Please refer to the index (p. 506).

Dimensions (unit: mm)

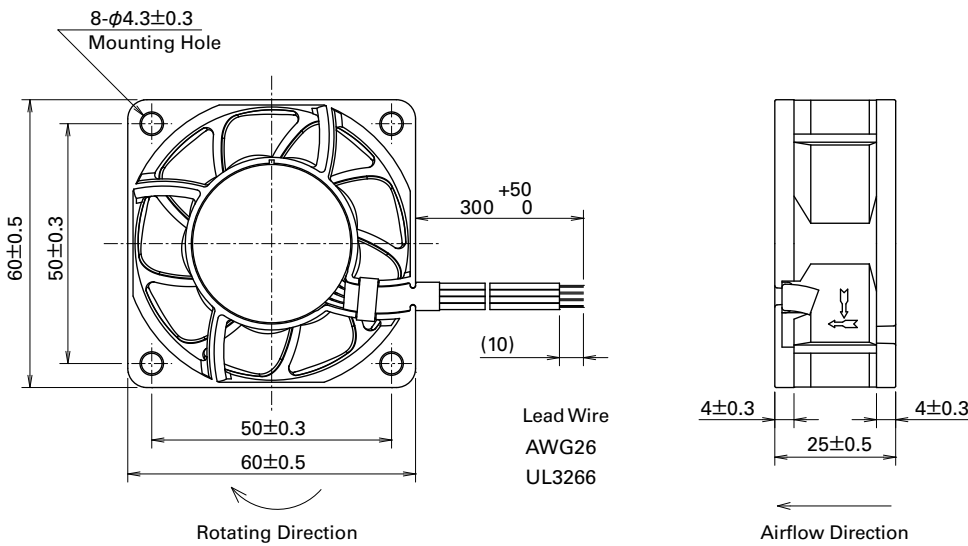

Reference Dimensions of Mounting Holes and Vent Opening (unit: mm)

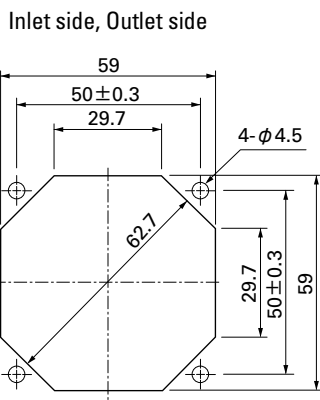

Options (unit: mm)

Finger Guards

Model : 109-139E Surface treatment : Nickel-chrome plating (silver)
: 109-139H : Cation electropainting (black)

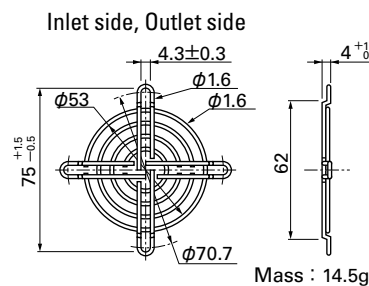

Airflow - Static Pressure Characteristics

PWM Duty Cycle

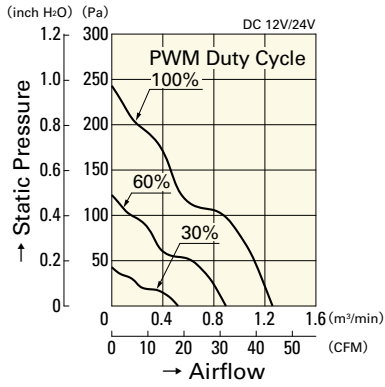

9GT0612P4G001

9GT0624P4G001

Operating Voltage Range

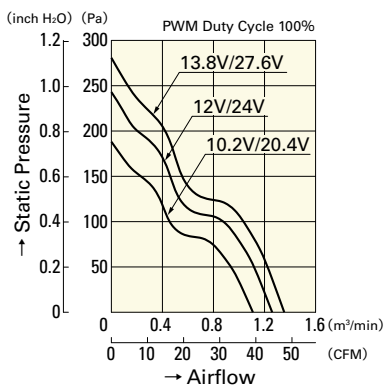

9GT0612P4G001

9GT0624P4G001

PWM Duty - Speed Characteristics Example

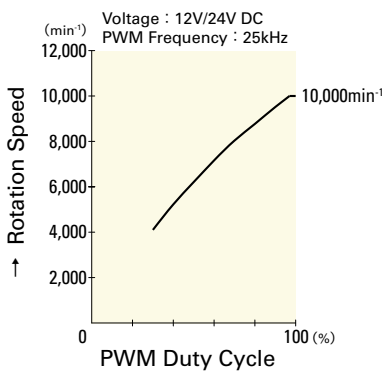

9GT0612P4G001

9GT0624P4G001

DC

Wide Temperature Range Fan 60mm

80 mm sq.

San Ace 80T



General Specifications

- Material Frame: Aluminum, Impeller: Plastics (Flammability: UL94V-1)
- Expected Life Refer to specifications (L10:Survival rate:90% at 85°C ,
rated voltage, and continuously run in a free air state)
- Lead Wire ⊕red ⊖black (Sensor) yellow (Control) brown
- Storage Temperature -40°C to +85°C (Non-condensing)

80×80×25 mm (Mass : 130g) **9GT** type

Specifications

The following nos. **have PWM controls and pulse sensors.**

Model No.	Rated Voltage [V]	Operating Voltage Range [V]	PWM duty cycle [※] [%]	Rated Current [A]	Rated Input [W]	Rated Speed [min ⁻¹]	Max. Airflow [m ³ /min] [CFM]	Max. Static Pressure [Pa] [InchH ₂ O]	SPL [dB(A)]	Operating Temperature [°C]	Expected Life [h]
9GT0812P4S001	12	10.2 to 13.8	100	0.46	5.52	6,700	1.86 65.7	143 0.57	46	-40 to +85	40,000/85°C
			30	0.09	1.08	2,650	0.73 25.7	22.3 0.08	26		
9GT0824P4S001	24	20.4 to 27.6	100	0.22	5.28	6,700	1.86 65.7	143 0.57	46		
			30	0.05	1.20	2,650	0.73 25.7	22.3 0.08	26		

Note : Fan does not rotate when PWM duty cycle is 0%.

※PWM Frequency : 25kHz

Other sensor specifications are available as options. Please refer to the index (pp. 506 to 507).

Dimensions (unit: mm)

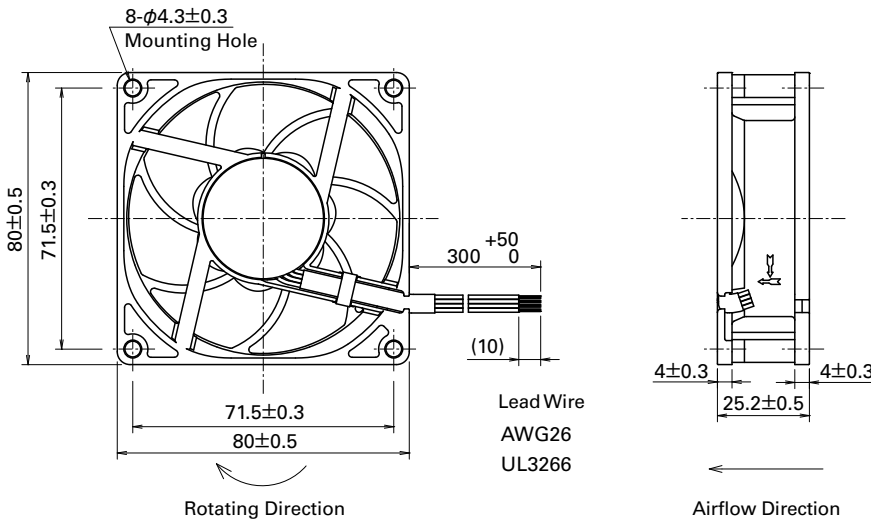

Options (unit: mm)

Finger Guards

Model : 109-049C Surface treatment : Nickel-chrome plating (silver) Color

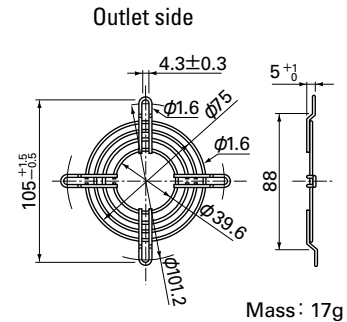

Model : 109-049E Surface treatment : Nickel-chrome plating (silver) Color
: 109-049H : Cation electropainting (black)

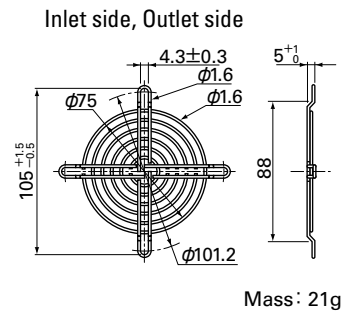

Reference Dimensions of Mounting Holes and Vent Opening (unit: mm)

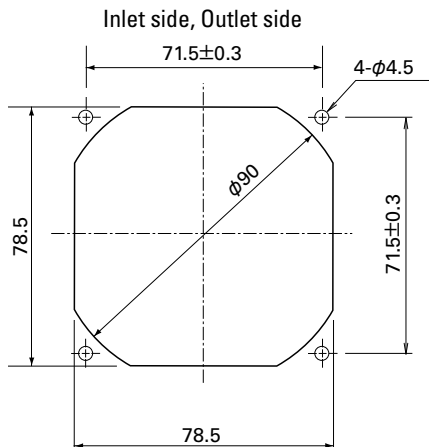

Airflow - Static Pressure Characteristics

PWM Duty Cycle

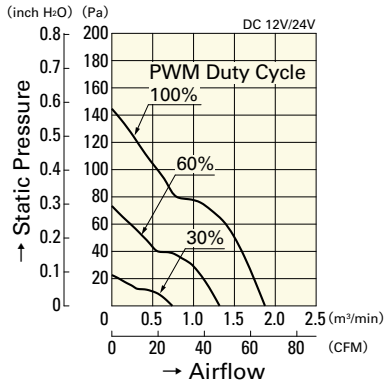

9GT0812P4S001

9GT0824P4S001

Operating Voltage Range

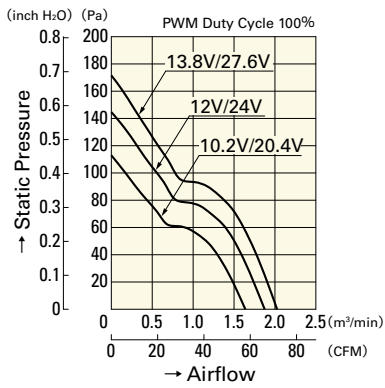

9GT0812P4S001

9GT0824P4S001

PWM Duty - Speed Characteristics Example

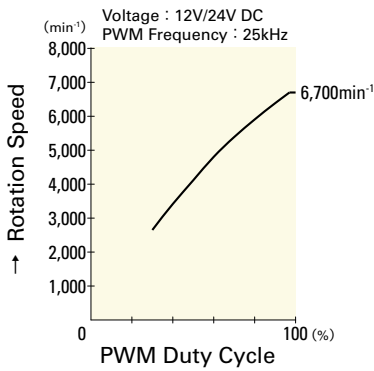

9GT0812P4S001

9GT0824P4S001

DC

Wide Temperature Range Fan 80mm

92mm sq.

San Ace 92T



General Specifications

- Material..... Frame: Aluminum, Impeller: Plastics (Flammability: UL94V-1)
- Expected Life Refer to specifications (L10:Survival rate:90% at 85°C ,
rated voltage, and continuously run in a free air state)
- Lead Wire ⊕red ⊖black (Sensor) yellow (Control) brown
- Storage Temperature ... -40°C to +85°C (Non-condensing)

92×92×25mm (Mass : 150g) **9GT type**

Specifications

The following nos. **have PWM controls and pulse sensors.**

Model No.	Rated Voltage [V]	Operating Voltage Range [V]	PWM duty cycle [※] [%]	Rated Current [A]	Rated Input [W]	Rated Speed [min ⁻¹]	Max. Airflow [m ³ /min] [CFM]	Max. Static Pressure [Pa] [InchH ₂ O]	SPL [dB(A)]	Operating Temperature [°C]	Expected Life [h]
9GT0912P4J001	12	10.2 to 13.8	100	0.42	5.04	5,000	2.20 77.7	105 0.42	44	-40 to +85	40,000/85°C
			30	0.07	0.84	1,850	0.81 28.7	14.3 0.05	18		
9GT0924P4J001	24	20.4 to 27.6	100	0.21	5.04	5,000	2.20 77.7	105 0.42	44		
			30	0.05	1.20	1,850	0.81 28.7	14.3 0.05	18		

Note : Fan does not rotate when PWM duty cycle is 0%.

※PWM Frequency : 25kHz

Other sensor specifications are available as options. Please refer to the index (p. 507).

Dimensions (unit: mm)

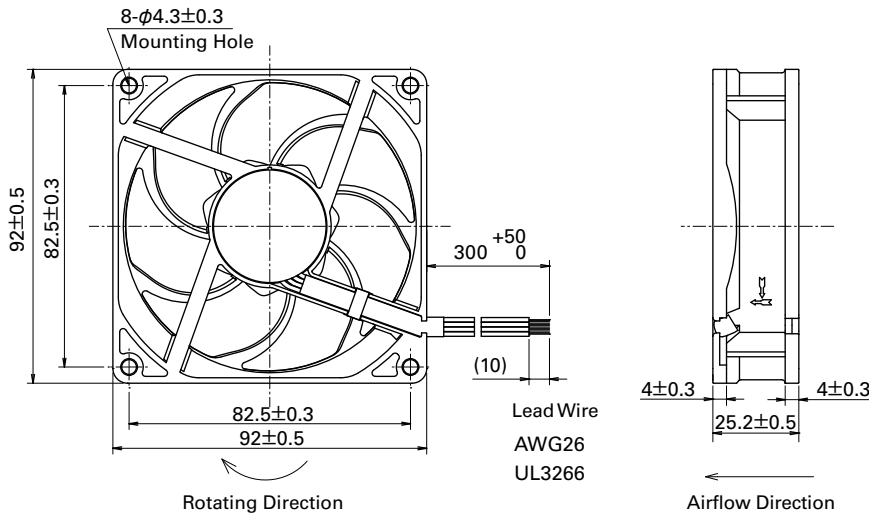

Options (unit: mm)

Finger Guards

Model : 109-099C Surface treatment : Nickel-chrome plating (silver) Color

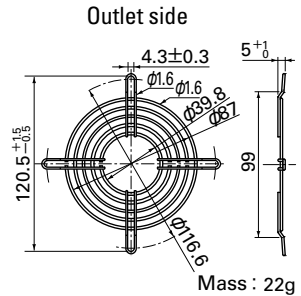

Model : 109-099E Surface treatment : Nickel-chrome plating (silver) Color
: 109-099H : Cation electropainting (black)

Inlet side, Outlet side

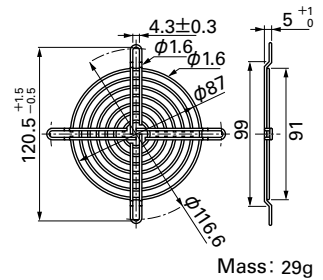

Reference Dimensions of Mounting Holes and Vent Opening (unit: mm)

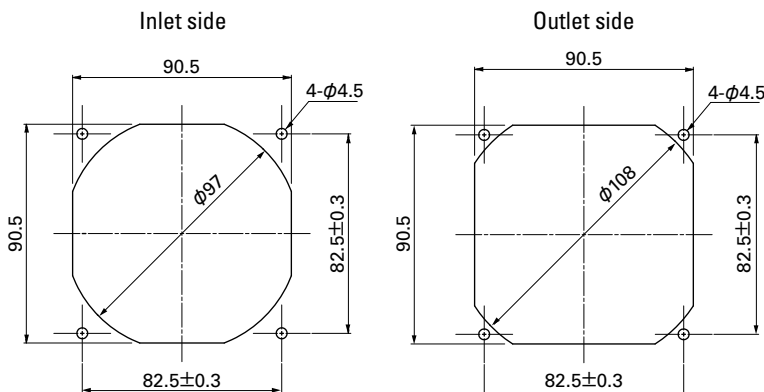

Airflow - Static Pressure Characteristics

PWM Duty Cycle

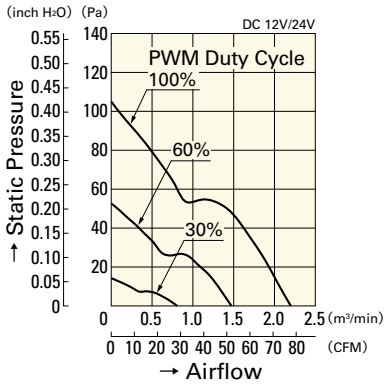

9GT0912P4J001

9GT0924P4J001

Operating Voltage Range

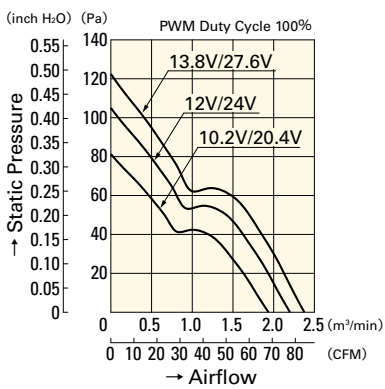

9GT0912P4J001

9GT0924P4J001

PWM Duty - Speed Characteristics Example

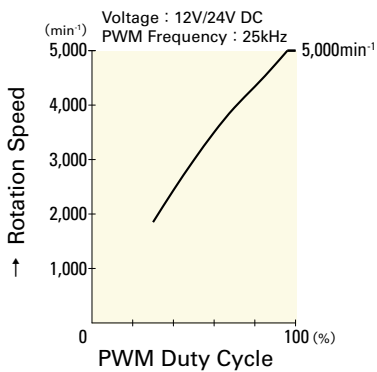

9GT0912P4J001

9GT0924P4J001

DC

Wide Temperature Range Fan 92mm

92mm sq.

San Ace 92T



General Specifications

- Material Frame: Aluminum, Impeller: Plastics (Flammability: UL94V-1)
- Expected Life Refer to specifications (L10:Survival rate:90% at 85°C ,
rated voltage, and continuously run in a free air state)
- Lead Wire ⊕red ⊖black (Sensor) yellow (Control) brown
- Storage Temperature -40°C to +85°C (Non-condensing)

92×92×38mm (Mass : 270g) **9GT** type

Specifications

The following nos. **have PWM controls and pulse sensors.**

Model No.	Rated Voltage [V]	Operating Voltage Range [V]	PWM duty cycle [※] [%]	Rated Current [A]	Rated Input [W]	Rated Speed [min ⁻¹]	Max. Airflow [m ³ /min] [CFM]	Max. Static Pressure [Pa] [InchH ₂ O]	SPL [dB(A)]	Operating Temperature [°C]	Expected Life [h]
9GT0912P1M001	12	10.2 to 13.8	100	1.50	18.0	8,100	3.30 116.6	315 1.26	58	-40 to +85	40,000/85°C
			30	0.30	3.6	3,750	1.50 53.0	72.0 0.29	37		
9GT0924P1M001	24	20.4 to 27.6	100	0.75	18.0	8,100	3.30 116.6	315 1.26	58		
			30	0.15	3.6	3,750	1.50 53.0	72.0 0.29	37		

Note : Fan does not rotate when PWM duty cycle is 0%.

※PWM Frequency : 25kHz

Other sensor specifications are available as options. Please refer to the index (p. 507).

Dimensions (unit: mm)

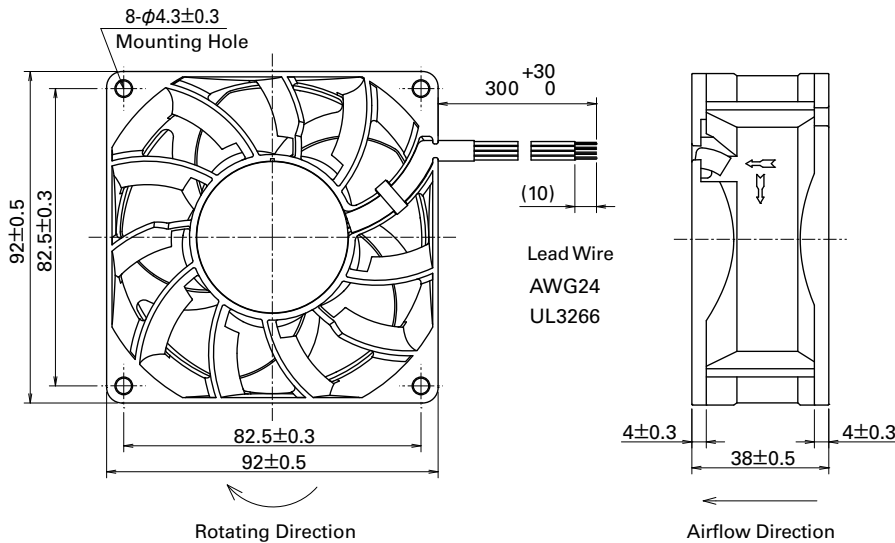

Options (unit: mm)

Finger Guards

Model : 109-099C Surface treatment : Nickel-chrome plating (silver) Color : Nickel-chrome plating (silver)

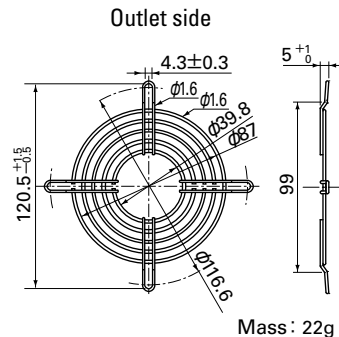

Model : 109-099E Surface treatment : Nickel-chrome plating (silver) Color : Nickel-chrome plating (silver)
: 109-099H Surface treatment : Cation electropainting (black) Color : Cation electropainting (black)

Inlet side, Outlet side

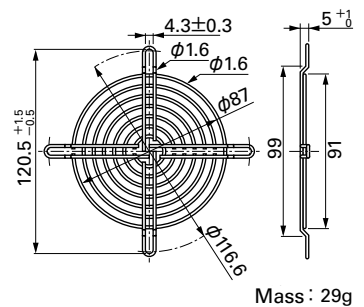

Reference Dimensions of Mounting Holes and Vent Opening (unit: mm)

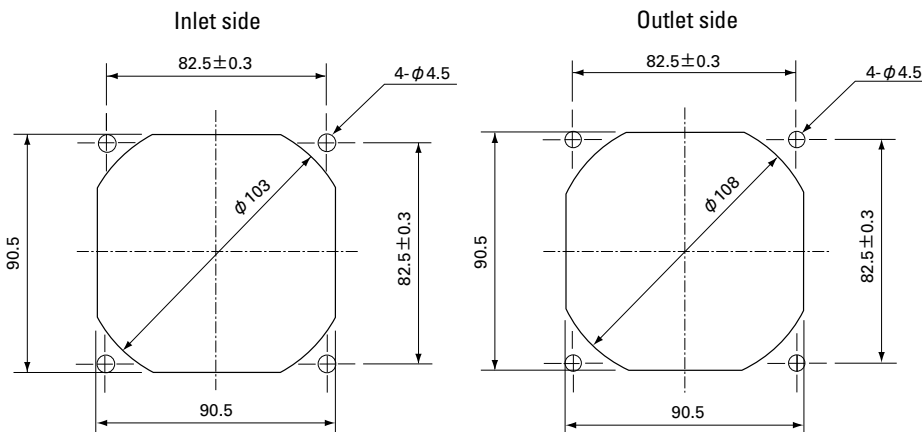

Airflow - Static Pressure Characteristics

PWM Duty Cycle

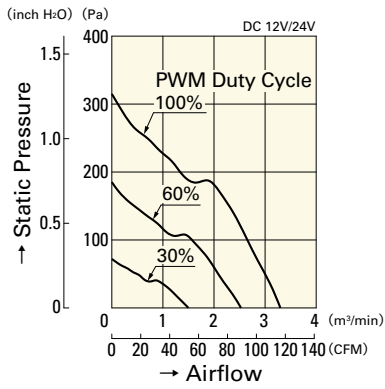

9GT0912P1M001

9GT0924P1M001

Operating Voltage Range

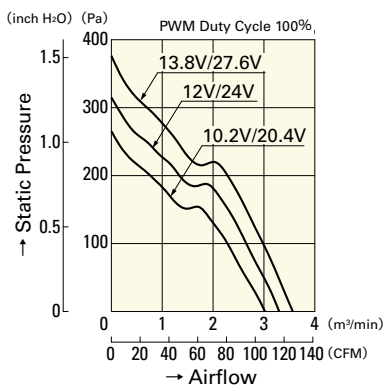

9GT0912P1M001

9GT0924P1M001

PWM Duty - Speed Characteristics Example

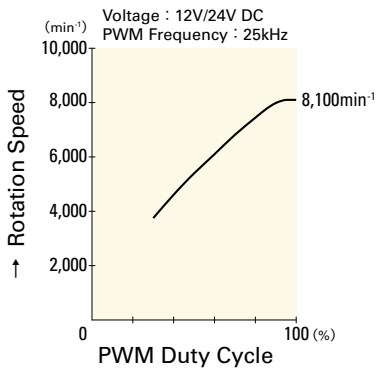

9GT0912P1M001

9GT0924P1M001

DC

Wide Temperature Range Fan 92mm

120mm sq.

San Ace 120T



General Specifications

- Material Frame: Aluminum, Impeller: Plastics (Flammability: UL94V-1)
- Expected Life Refer to specifications (L10:Survival rate:90% at 85°C ,
rated voltage, and continuously run in a free air state)
- Lead Wire ⊕red ⊖black (Sensor) yellow (Control) brown
- Storage Temperature -40°C to +85°C (Non-condensing)

120×120×38mm [Mass : 420g] **9GT type**

Specifications

The following nos. **have PWM controls and pulse sensors.**

Model No.	Rated Voltage [V]	Operating Voltage Range [V]	PWM duty cycle ^{Notes} [%]	Rated Current [A]	Rated Input [W]	Rated Speed [min ⁻¹]	Max. Airflow [m ³ /min] [CFM]	Max. Static Pressure [Pa] [InchH ₂ O]	SPL [dB(A)]	Operating Temperature [°C]	Expected Life [h]
9GT1212P1S001	12	9.0 to 13.8	100	2.2	26.4	5,600	6.00 211.8	270 1.08	58	-40 to +85	40,000/85°C
			35	0.48	5.76	2,900	3.00 106.0	85.6 0.34	41		
9GT1224P1S001	24	18.0 to 27.6	100	1.1	26.4	5,600	6.00 211.8	270 1.08	58		
			35	0.24	5.76	2,900	3.00 106.0	85.6 0.34	41		

Note : Fan does not rotate when PWM duty cycle is 0%.

※PWM Frequency : 25kHz

Other sensor specifications are available as options. Please refer to the index (p. 507).

Dimensions (unit: mm)

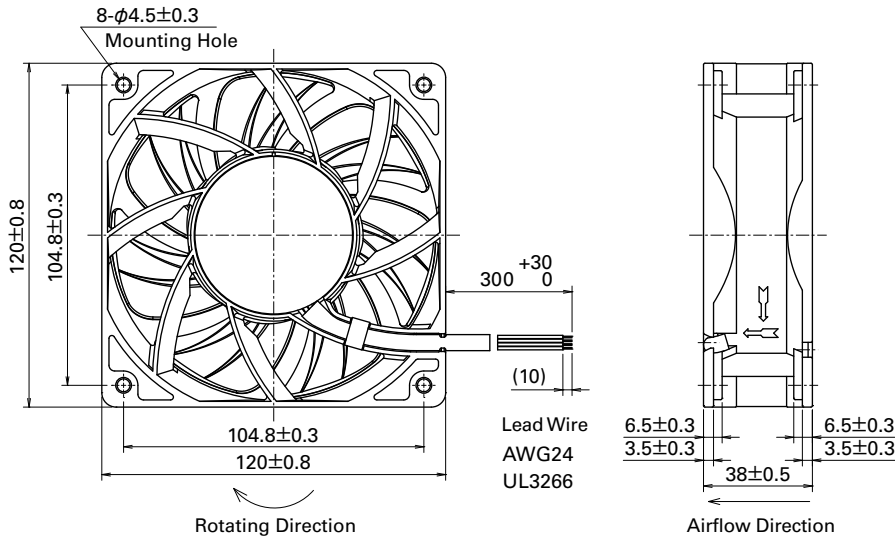

Options (unit: mm)

Finger Guards

Model : 109-019C Surface treatment : Nickel-chrome plating (silver)
: 109-019H : Cation electropainting (black)

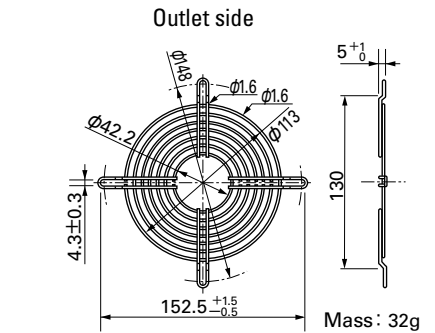

Model : 109-019E Surface treatment : Nickel-chrome plating (silver)
: 109-019K : Cation electropainting (black)

Inlet side, Outlet side

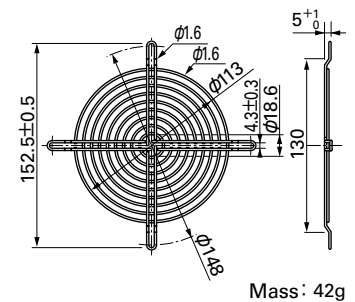

Reference Dimensions of Mounting Holes and Vent Opening (unit: mm)

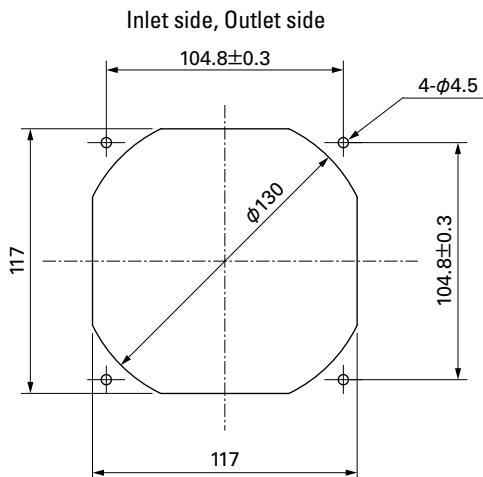

Airflow - Static Pressure Characteristics

PWM Duty Cycle

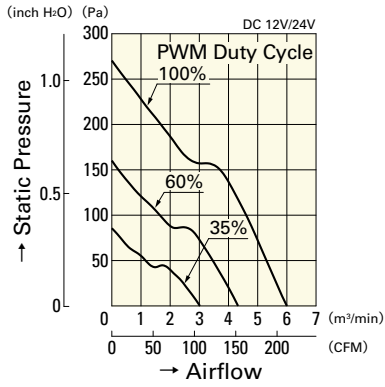

9GT1212P1S001

9GT1224P1S001

Operating Voltage Range

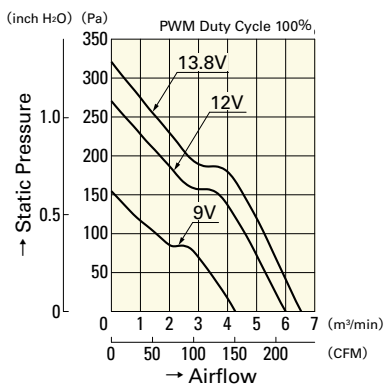

9GT1212P1S001

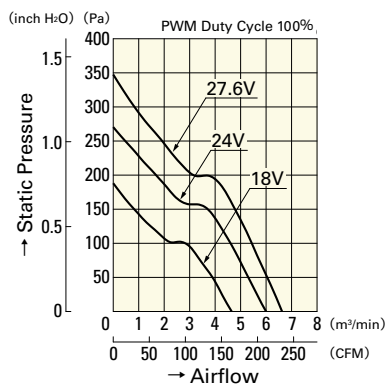

9GT1224P1S001

PWM Duty - Speed Characteristics Example

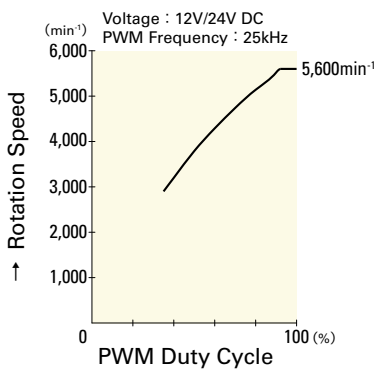

9GT1212P1S001

9GT1224P1S001

DC

Wide Temperature Range Fan 120mm

Centrifugal Fan

Cooling fan blows air in a centrifugal course. It features high static pressure.

Related product

Splash Proof Centrifugal Fan ⇒ p. 293

Domain Diagram

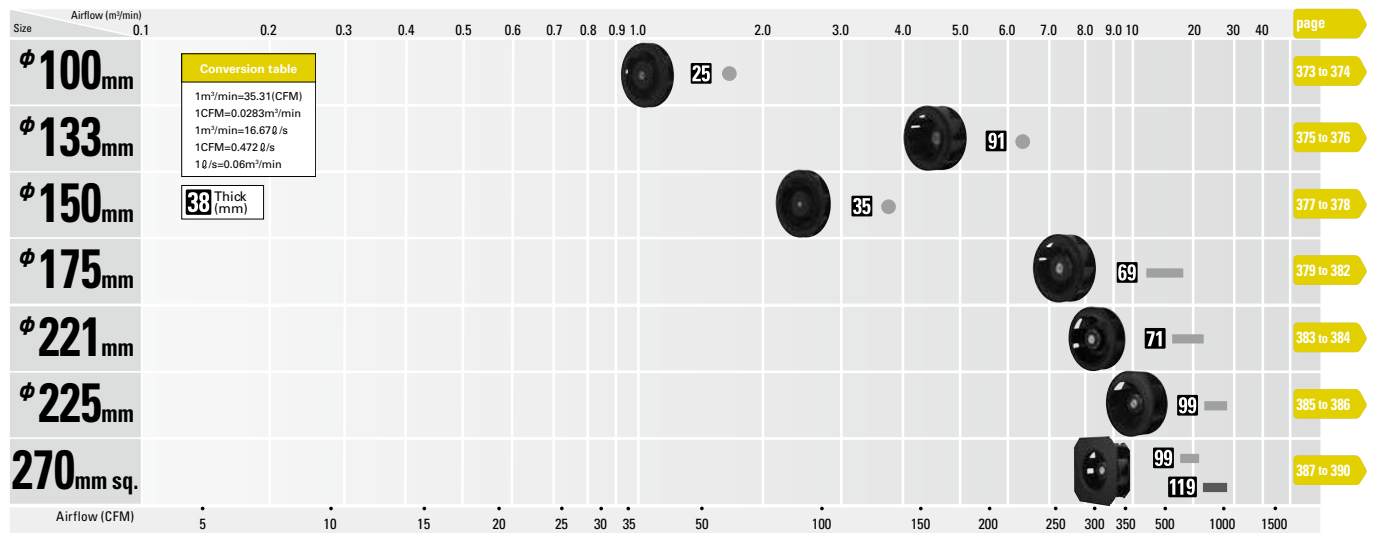

Model Numbering System

Not every combination of the following codes or characters is available. Contact us for an available combination.

9T	M	48	P	4	H	01
Type name 9T: Centrifugal Fan	Impeller size M: φ100mm J: φ133mm N: φ150mm G: φ175mm P: φ221mm S: φ225mm GA: φ175mm	Voltage 24: 24V 48: 48V	PWM control function P	Frame thickness 0: 69mm thick MIN 1: 35mm thick 4: 25mm thick	Speed code H,G etc	Individual customer's spec 2 or 3 digits

Bracket-mounted Centrifugal Fan

9B1T	P	48	P	0	H	001
Type name 9B1T: Bracket-mounted Centrifugal Fan	Impeller size P: φ221mm S: φ225mm	Voltage 24: 24V 48: 48V	PWM control function P	Frame thickness 0: 99mm thick / 119mm thick	Speed code H,G etc	Individual customer's spec 3 digits

How to Read Specifications

DC Fan											DC	
Model No.	① Rated Voltage [V]	② Operating Voltage Range [V]	③ Rated Current [A]	④ Rated Input [W]	⑤ Rated Speed [min ⁻¹]	⑥ Max. Airflow [m ³ /min] [CFM]		⑦ Max. Static Pressure [Pa] [inchH ₂ O]		⑧ SPL [dB(A)]	⑨ Operating Temperature [°C]	⑩ Expected Life [h]
9GA0412G7001	12	7 to 13.8	0.17	2.04	13,100	0.36	12.7	192	0.77	42	-20 to +70	40,000/60°C (70,000/40°C)

- ① Rated Voltage This is the necessary voltage to drive the fan. 12VDC, 24VDC and 48VDC are available.
- ② Operating Voltage Range The voltage range over which fan operation is guaranteed
- ③ Rated Current The current value during the fan's rated operation without load
- ④ Rated Input The input value during the fan's rated operation without load
- ⑤ Rated Speed The rotating speed during the fan's rated operation without load
- ⑥ Max. Airflow The maximum air volume that the fan can output during rated operation (according to the company's dual-chamber device).
The volume of air generated by the fan in a given time period
- ⑦ Max. Static Pressure The maximum static pressure value that the fan can output during rated operation (according to the company's dual-chamber device). The static pressure is the fan's force to propel air by overcoming the resistance of the device that uses the fan when it propels air.
- ⑧ SPL "SPL" is Sound Pressure Level. The noise level during the fan's rated operation.
Please refer to the technical material section for the method used to measure the noise level.
- ⑨ Operating Temperature The temperature range over which fan operation is guaranteed (Non- condensing)
- ⑩ Expected Life The fan's expected operating life when the fan operates continuously at the rated voltage at a temperature of 60°C and at relative humidity of 90%. Expected life at 40°C ambient is just reference value.
Please refer to the technical material section for the expected operating life.

DC Fan Common Specifications

Material Frame,Impeller:Plastics / Frame:Aluminum,Impeller:Plastics

* For details, refer to the appropriate page.

Expected Life Varies for each model (L10:Survival rate:90% at 60°C ,rated voltage, and continuously run in a free air state)

* Splash proof fan: Varies for each model (Indoor, L10:Survival rate:90% at 60°C ,rated voltage, and continuously run in a free air state)

Motor Protection Burnout protection at locked rotor condition and Reverse polarity protection

Dielectric Strength AC50/60Hz 500VAC 1minute(between lead conductor and frame)

Insulation Resistance 10M Ω or more at 500VDC megger (between lead conductor and frame)

Sound Pressure Level(SPL) Expressed as the value at 1m from air inlet side

Lead Wire For details, refer to the appropriate page.

Overheating protection function

Protection Functions:

If the fan blades are restricted, an overcurrent occurs and leads to a rise in the fan coil temperature. This can result in reduced performance, damage, or a fire. To prevent this from occurring, SANYO DENKI's fans incorporate an overheating protection function. Refer to the catalog for the types of protection functions.

Burnout protection function at locked rotor condition

- Current cutoff system

If the fan blades are restricted, the coil current is cut off at regular cycles to prevent overheating of the coil. When the hindrance is removed, the fan restarts automatically.

Reverse polarity protection function

No problem about fan even if positive & negative lead are connected in reverse.

However, when wiring fans with sensors or PWM speed control function, connecting positive and negative leads in reverse may damage the fans.

φ 100_{mm}

San Ace C100



General Specifications

- Material Motor case: Aluminum,
Impeller: Plastics (Flammability: UL94V-0)
- Expected Life Refer to specifications (L10:Survival rate: 90% at 60°C ,
rated voltage, and continuously run in a free air state)
- Lead Wire ⊕red ⊖black (Sensor) yellow (Control) brown
- Storage Temperature -30°C to +70°C (Non-condensing)

φ 100mm × 25mm (Mass : 150g) **9T type**

Specifications When our inlet nozzle [Option (Model NO. : 109-1080)] is mounted. The following nos. **have PWM controls and pulse sensors.**

Model No.	Rated Voltage [V]	Operating Voltage Range [V]	PWM duty cycle* [%]	Rated Current [A]	Rated Input [W]	Rated Speed [min ⁻¹]	Max. Airflow [m ³ /min] [CFM]	Max. Static Pressure [Pa] [inchH ₂ O]	SPL [dB(A)]	Operating Temperature [°C]	Expected Life [h]
9TM24P4H01	24	21.6 to 26.4	100	0.44	10.56	6,400	1.77 62.5	560 2.25	60	-20 to +70	40,000/60°C
			0	0.05	1.2	2,000	0.51 18.0	48 0.19	34		
9TM48P4H01	48	36 to 60	100	0.22	10.56	6,400	1.77 62.5	560 2.25	60	-20 to +70	40,000/60°C
			0	0.04	1.92	2,000	0.51 18.0	48 0.19	34		

Note : Max input is 14W at rated voltage.

※ PWM Frequency : 25kHz

Dimensions (unit: mm)

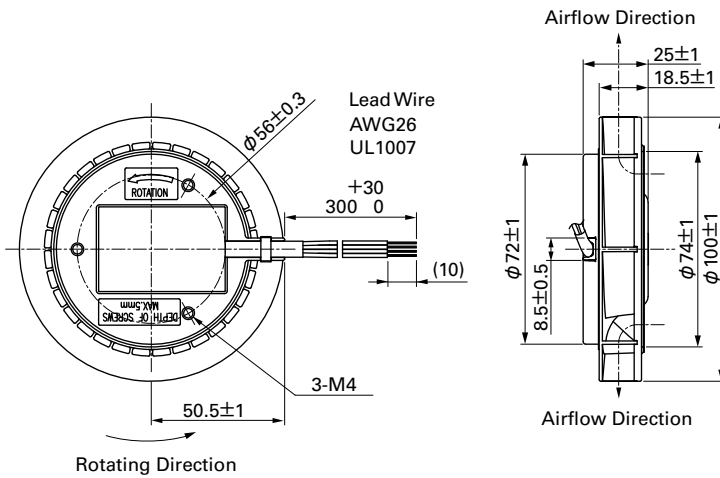

Reference Dimensions of Mounting Holes and Vent Opening (unit: mm)

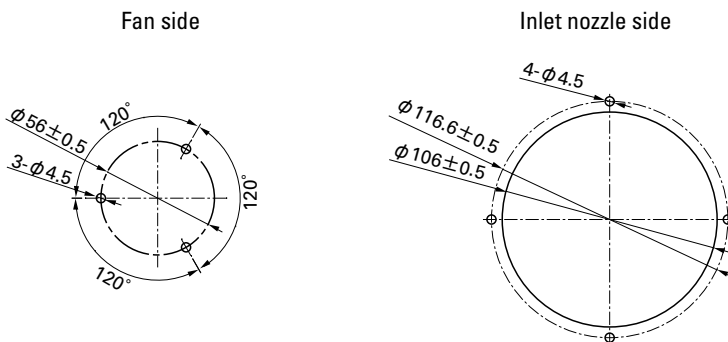

Options (unit: mm)

Inlet Nozzle

Model : 109-1080 Material: Steel sheet Surface treatment: Electro nickel plating (silver) Color

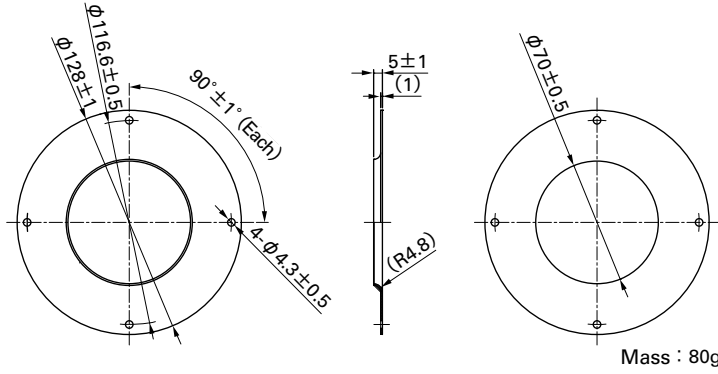

Finger Guards

Model : 109-099E Surface treatment : Nickel-chrome plating (silver) Color : 109-099H : Cation electropainting (black)

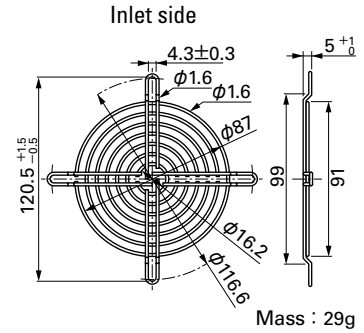

Inlet nozzle: Equipment to be mounted in inlet side for adjusting incoming airflow.

Reference Diagram for Mounting

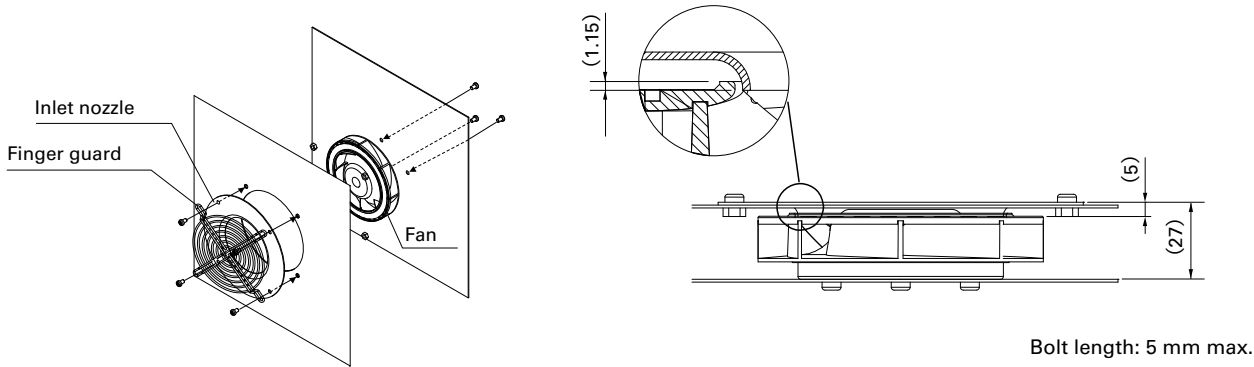

Bolt length: 5 mm max.

Airflow - Static Pressure Characteristics

PWM Duty Cycle

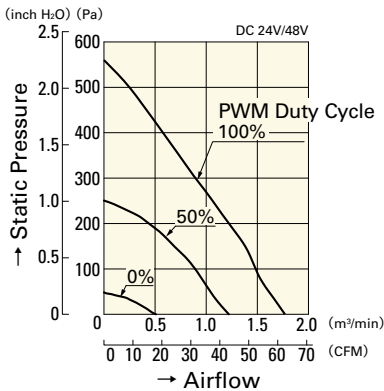

9TM24P4H01
9TM48P4H01

Operating Voltage Range

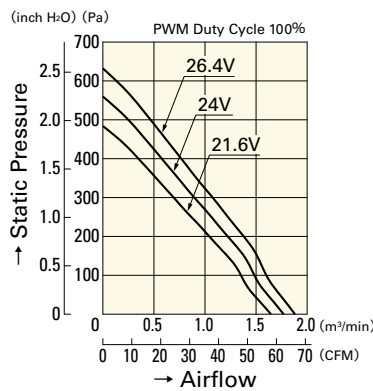

9TM24P4H01

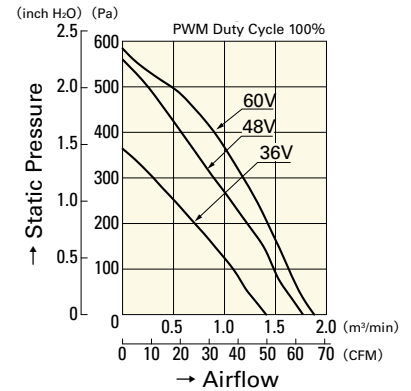

9TM48P4H01

PWM Duty - Speed Characteristics Example

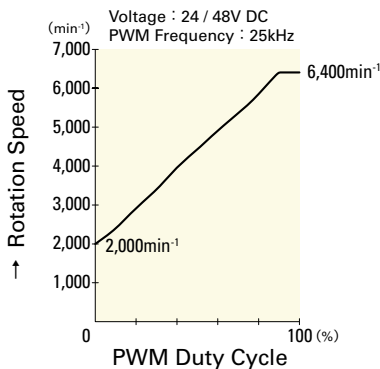

9TM24P4H01
9TM48P4H01

φ133mm

San Ace C133

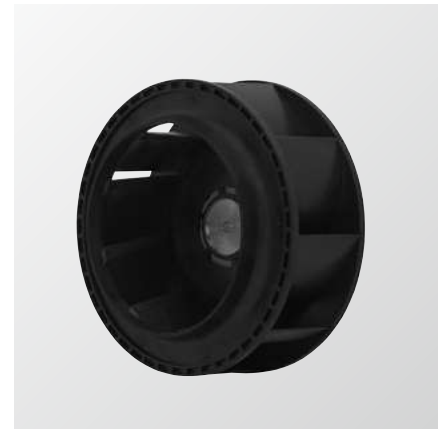

General Specifications

- Material..... Motor case: Aluminum,
Impeller: Plastics (Flammability: UL94V-0)
- Expected Life Refer to specifications (L10:Survival rate: 90% at 60°C ,
rated voltage, and continuously run in a free air state)
- Lead Wire ⊕red ⊖black (Sensor) yellow (Control) brown
- Storage Temperature -30°C to +70°C (Non-condensing)

φ133mm×91mm (Mass : 660g) **9T type**

Specifications When our inletnozzle [Option (Model : 109-1069)] is mounted. The following nos. **have PWM controls and pulse sensors.**

Model No.	Rated Voltage [V]	Operating Voltage Range [V]	PWM duty cycle ^{Note①} [%]	Rated Current [A]	Rated Input [W]	Rated Speed [min ⁻¹]	Max. Airflow [m ³ /min] [CFM]	Max. Static Pressure [Pa] [inchH ₂ O]	SPL [dB(A)]	Operating Temperature [°C]	Expected Life [h]
9TJ24P0H61	24	20.4 to 27.6	100	1.2	28.8	4,150	6.39 226	395 1.59	61	-20 to +70	40,000/60°C
9TJ48P0H01	48	36 to 72	100	0.55	26.4	4,150	6.39 226	395 1.59	61		

Note : Fan does not rotate when PWM duty cycle is 0%.

*PWM Frequency : 25kHz

Dimensions (unit: mm)

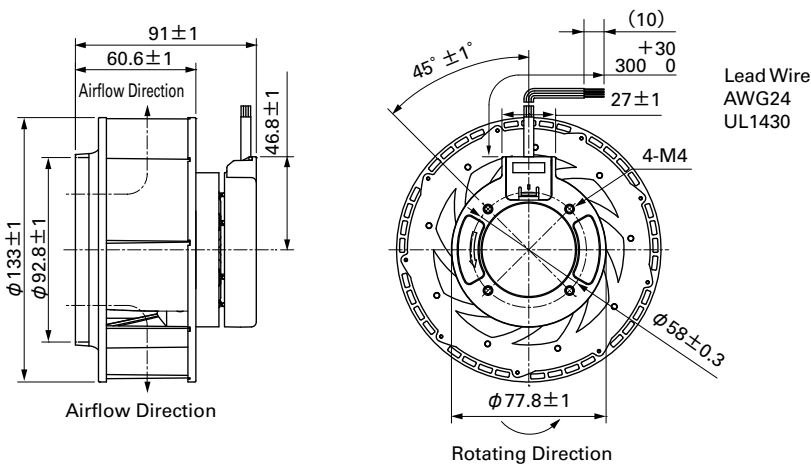

Reference Dimensions of Mounting Holes and Vent Opening (unit: mm)

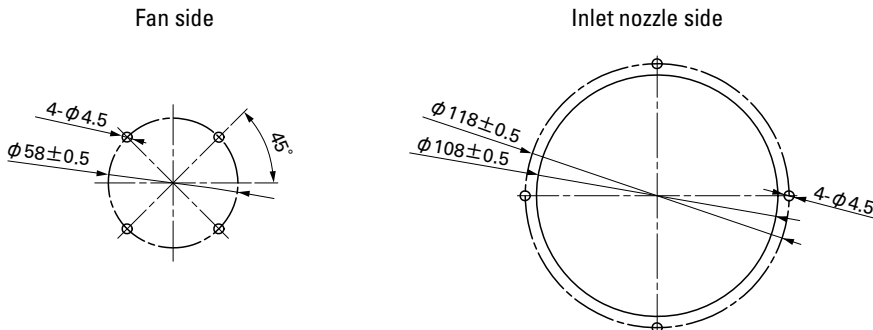

Options (unit: mm)

Inlet Nozzle

Model : 109-1069 Material : Steel sheet Surface treatment : Electro nickel plating Color (silver)
 : 109-1069H : Steel sheet : Cation electropainting (black)

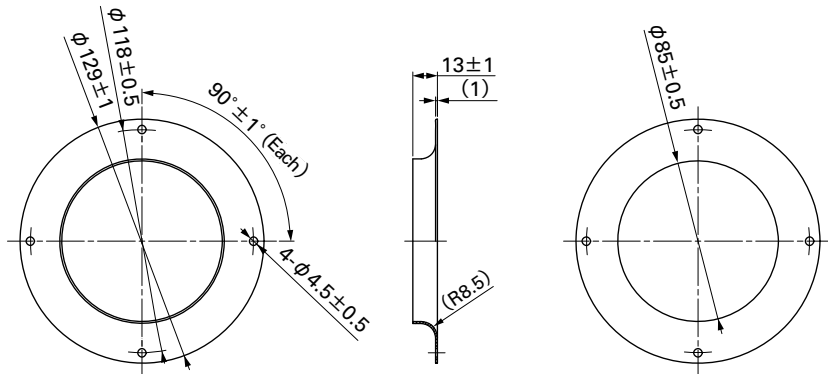

Mass : 76g

Finger Guards

Model : 109-1112 Surface treatment : Nickel-chrome plating (silver) Color (silver)

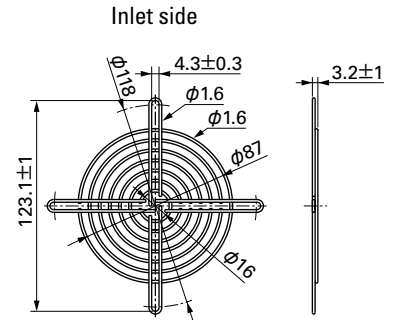

Mass : 65g

Inlet nozzle: Equipment to be mounted in inlet side for adjusting incoming airflow.

Reference Diagram for Mounting

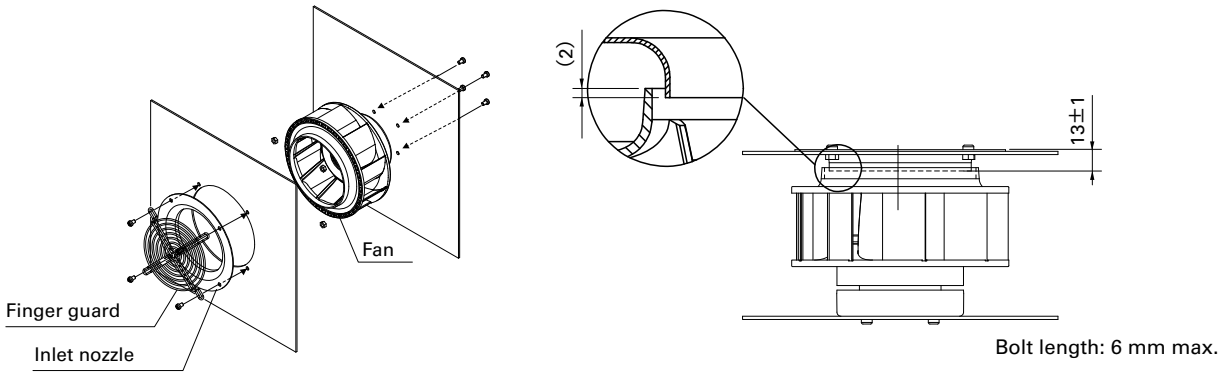

Airflow - Static Pressure Characteristics

PWM Duty Cycle

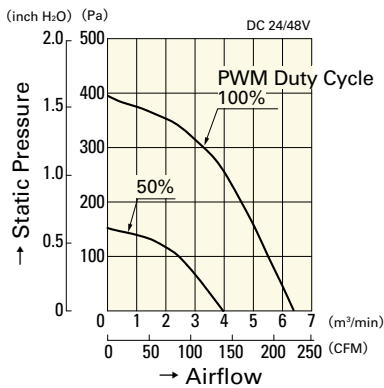

9TJ24P0H61
9TJ48P0H01

Operating Voltage Range

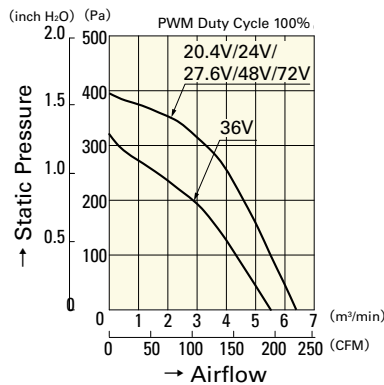

9TJ24P0H61
9TJ48P0H01

PWM Duty Speed Characteristics Example

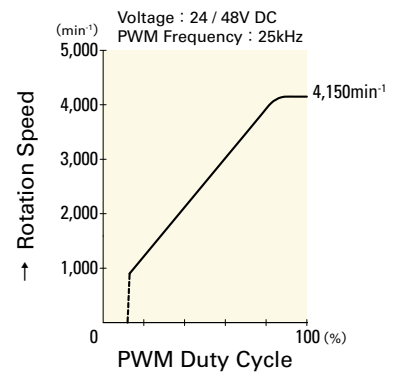

9TJ24P0H61
9TJ48P0H01

φ 150mm

San Ace C150



General Specifications

- Material Motor case: Aluminum,
Impeller: Plastics (Flammability: UL94V-0)
- Expected Life Refer to specifications (L10:Survival rate: 90% at 60°C ,
rated voltage, and continuously run in a free air state)
- Lead Wire ⊕red ⊖black (Sensor) yellow (Control) brown
- Storage Temperature -30°C to +70°C (Non-condensing)

φ 150mm × 35mm (Mass : 330g) **9T type**

Specifications When our inletnozzle[Option(Model : 109-1081)]is mounted. The following nos. **have PWM controls and pulse sensors.**

Model No.	Rated Voltage [V]	Operating Voltage Range [V]	PWM duty cycle ^{Max(F)} [%]	Rated Current [A]	Rated Input [W]	Rated Speed [min ⁻¹]	Max. Airflow [m ³ /min] [CFM]	Max. Static Pressure [Pa] [inchH ₂ O]	SPL [dB(A)]	Operating Temperature [°C]	Expected Life [h]
9TN24P1H01	24	20.4 to 27.6	100	0.62	14.9	3,800	3.83 135	410 1.65	59	-20 to +70	40,000/60°C
9TN48P1H01	48	36.0 to 55.2	100	0.32	15.4	3,800	3.83 135	390 1.57	59		

Note 1 : Fan does not rotate when PWM duty cycle is 0% .
Note 2 : Max input of 9TN24P1H01 : 21.4W, 9TN48P1H01 : 22W.

※PWM Frequency : 25kHz

Dimensions (unit: mm)

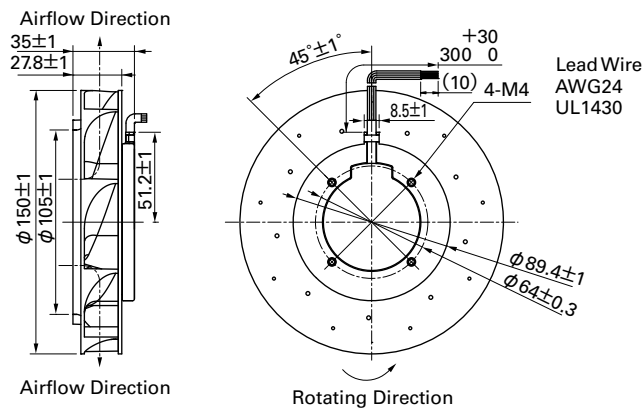

Reference Dimensions of Mounting Holes and Vent Opening (unit: mm)

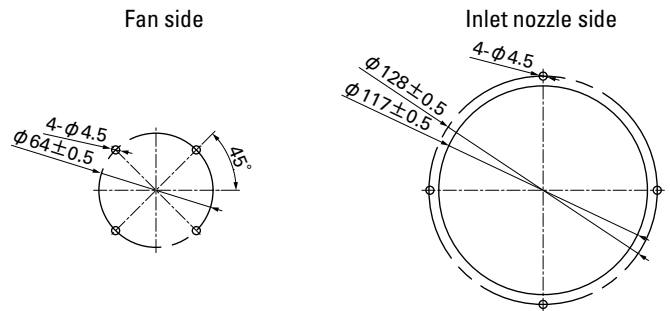

Options (unit: mm)

Inlet Nozzle

Model : 109-1081 Material : Steel sheet Surface treatment : Electro nickel plating (silver) Color : Steel sheet
: 109-1081H : Steel sheet : Cation electropainting (black)

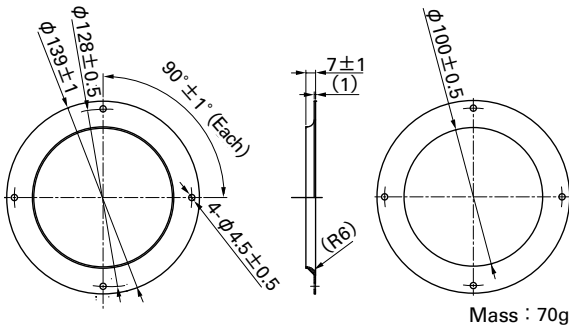

Inlet nozzle: Equipment to be mounted in inlet side for adjusting incoming airflow.

Finger Guards

Model : 109-1104 Surface treatment : Nickel-chrome plating (silver) Color : 109-1104H : Cation electropainting (black)

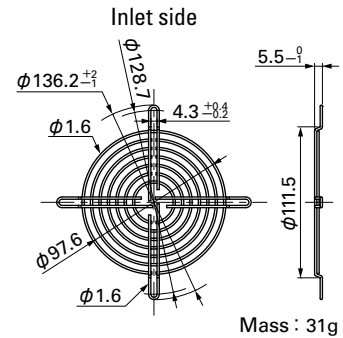

Reference Diagram for Mounting

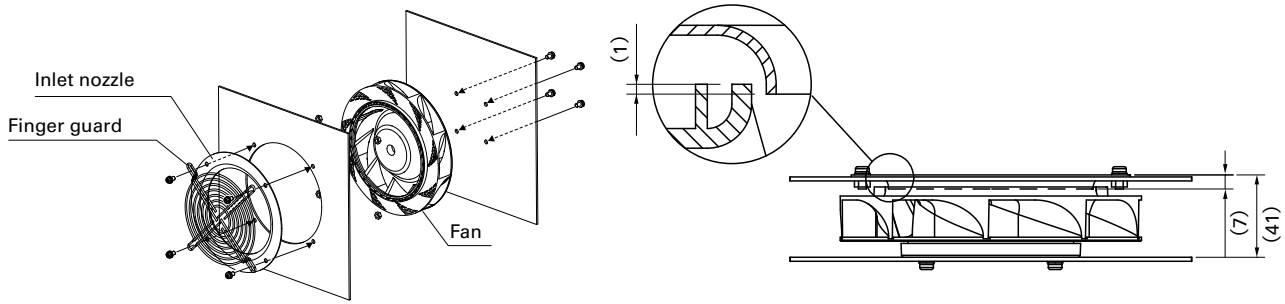

Bolt length: 4 to 6 mm.

Airflow - Static Pressure Characteristics

PWM Duty Cycle

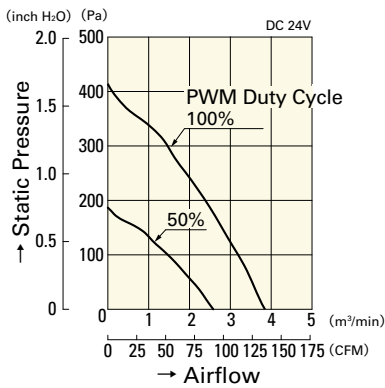

9TN24P1H01

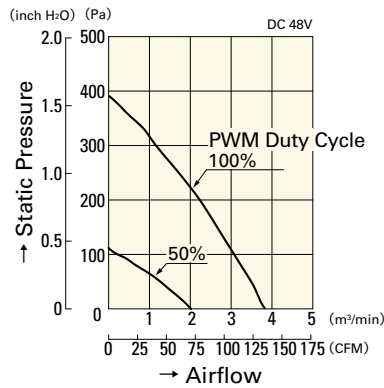

9TN48P1H01

Operating Voltage Range

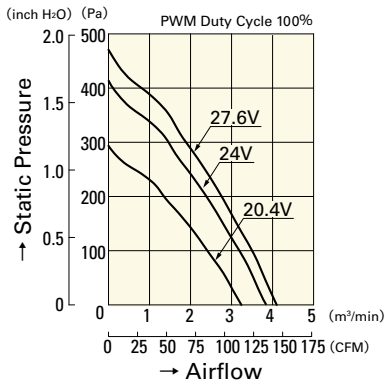

9TN24P1H01

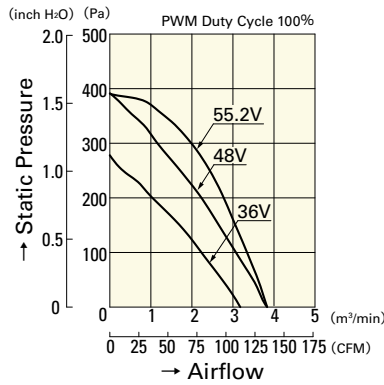

9TN48P1H01

PWM Duty - Speed Characteristics Example

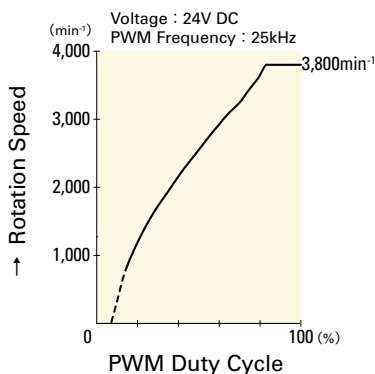

9TN24P1H01

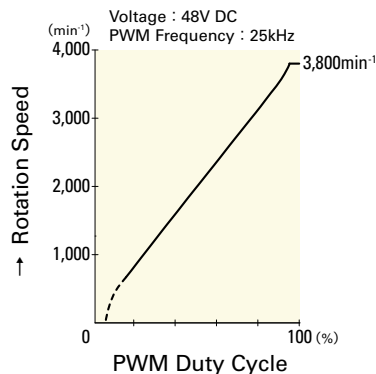

9TN48P1H01

φ 175mm

San Ace C175

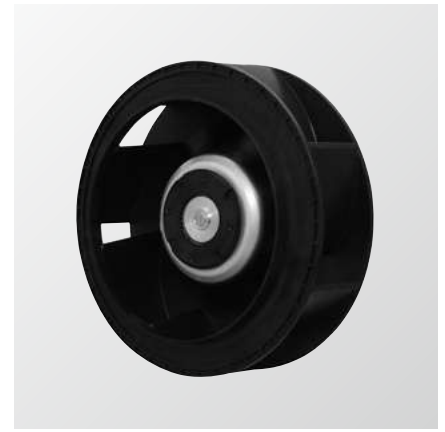

General Specifications

- Material Motor case: Aluminum,
Impeller: Plastics (Flammability: UL94V-0)
- Expected Life Refer to specifications (L10:Survival rate: 90% at 60°C ,
rated voltage, and continuously run in a free air state)
- Lead Wire ⊕red ⊖black (Sensor) yellow (Control) brown
- Storage Temperature -30°C to +70°C (Non-condensing)

φ 175mm × 69mm (Mass : 720g) **9T type**

Specifications

When inlet nozzle [Option (Model : 109-1073)] is mounted. The following nos. **have PWM controls and pulse sensors.**

Model No.	Rated Voltage [V]	Operating Voltage Range [V]	PWM duty cycle [※] [%]	Rated Current [A]	Rated Input [W]	Rated Speed [min ⁻¹]	Max. Airflow [m ³ /min] [CFM]	Max. Static Pressure [Pa] [inchH ₂ O]	SPL [dB(A)]	Operating Temperature [°C]	Expected Life [h]
9TGA24P0H001	24	16 to 36	100	4.8	115	4,950	15.3 541	830 3.33	77	-20 to +70	40,000/60°C (70,000/40°C)
			15	0.14	3.36	800	2.5 88.3	21.8 0.088	38		
9TGA48P0G001	48	36 to 72	100	3.5	168	5,700	17.6 622	1,100 4.42	80		
			15	0.07	3.36	800	2.5 88.3	21.8 0.088	38		

Note 1 : Fan does not rotate when PWM duty cycle is 0% .

※PWM Frequency : 25kHz

Note 2 : Max input of 9TGA24P0H001: 210 W, 9TGA48P0G001: 325 W at rated voltage.

Dimensions (unit: mm)

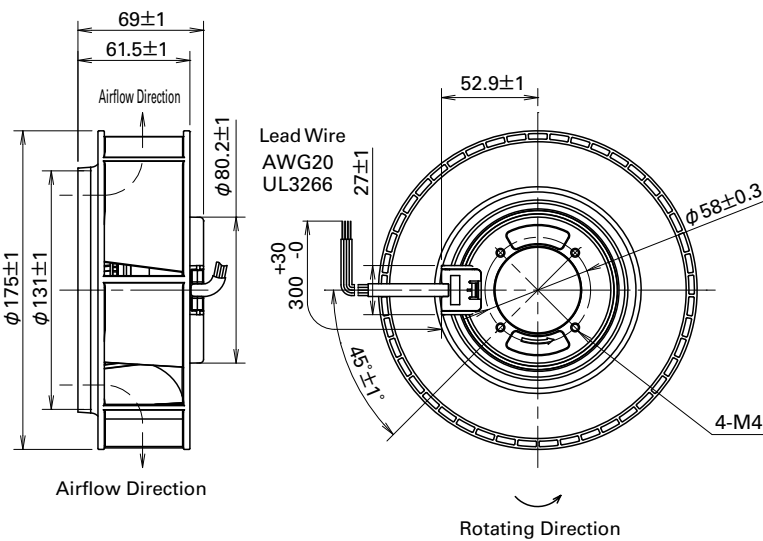

Reference Dimensions of Mounting Holes and Vent Opening (unit: mm)

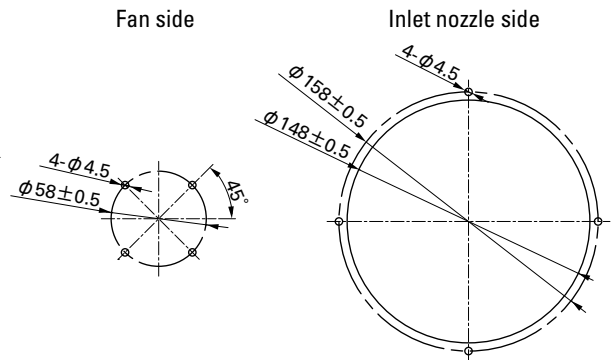

Options (unit: mm)

Inlet Nozzle

Model : 109-1073 Material : Steel sheet Surface treatment : Electro nickel plating Color (silver)
: 109-1073H : Steel sheet : Cation electropainting (black)

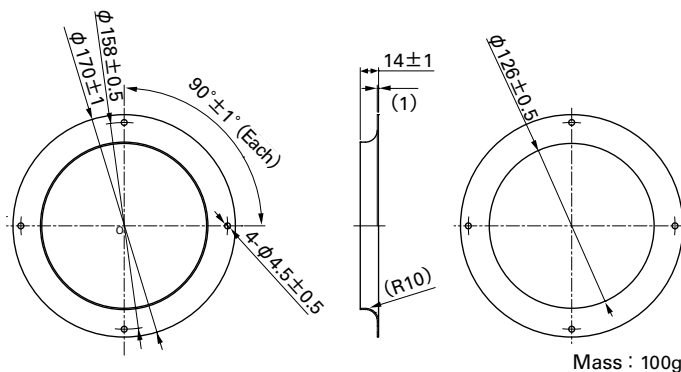

Finger Guards

Model : 109-722 Surface treatment : Nickel-chrome plating Color (silver)

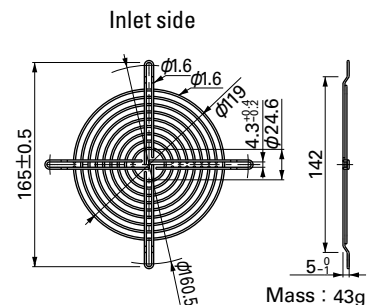

Inlet nozzle: Equipment to be mounted in inlet side for adjusting incoming airflow.

Reference Diagram for Mounting

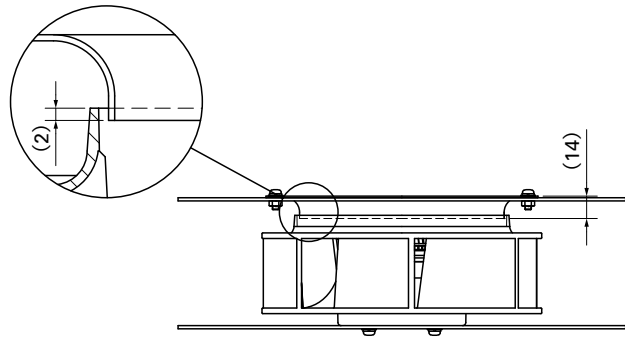
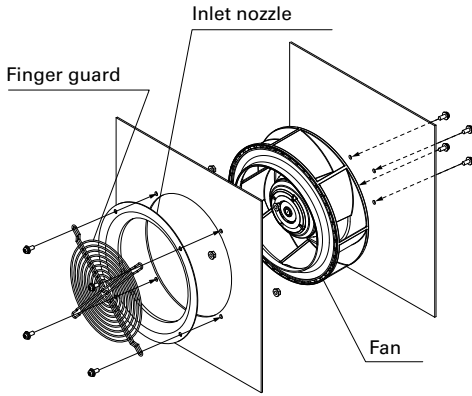

Bolt length: 6 mm max.

Airflow - Static Pressure Characteristics

PWM Duty Cycle

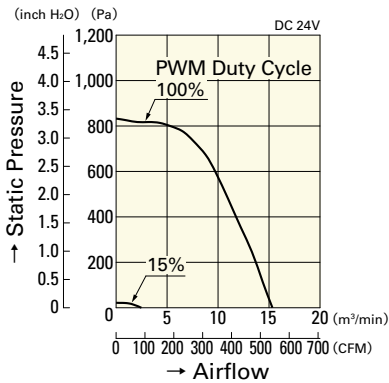

9TGA24P0H001

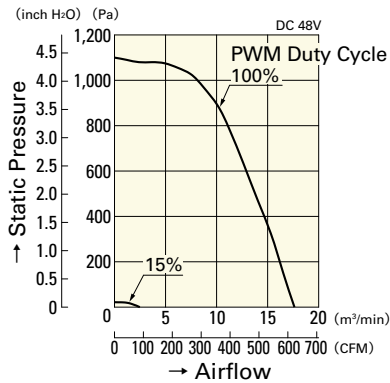

9TGA48P0G001

Operating Voltage Range

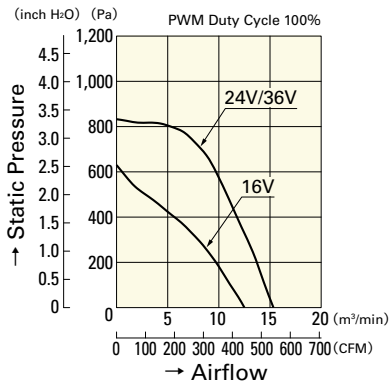

9TGA24P0H001

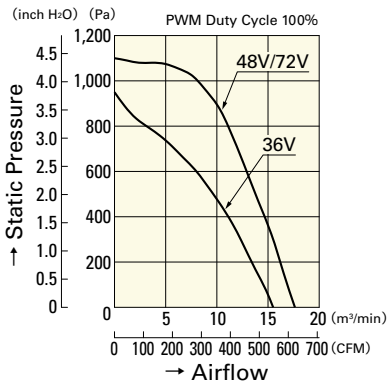

9TGA48P0G001

PWM Duty - Speed Characteristics Example

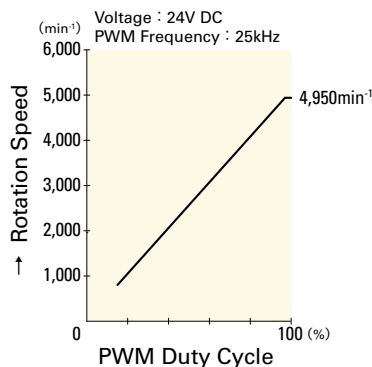

9TGA24P0H001

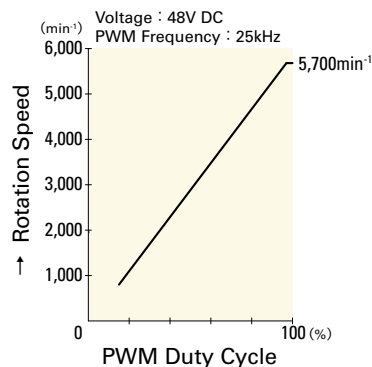

9TGA48P0G001

φ 175mm

San Ace C175



General Specifications

- Material Motor case: Aluminum,
Impeller: Plastics (Flammability: UL94V-0)
- Expected Life Refer to specifications (L10:Survival rate: 90% at 60°C ,
rated voltage, and continuously run in a free air state)
- Lead Wire ⊕red ⊖black (Sensor) yellow (Control) brown
- Storage Temperature -30°C to +70°C (Non-condensing)

φ 175mm × 69mm (Mass : 750g) **9T type**

Specifications

When inlet nozzle [Option (Model : 109-1073)] is mounted. The following nos. **have PWM controls and pulse sensors.**

Model No.	Rated Voltage [V]	Operating Voltage Range [V]	PWM duty cycle ^{Note(1)} [%]	Rated Current [A]	Rated Input [W]	Rated Speed [min ⁻¹]	Max. Airflow [m ³ /min] [CFM]	Max. Static Pressure [Pa] [inchH ₂ O]	SPL [dB(A)]	Operating Temperature [°C]	Expected Life [h]
9TG24P0G01	24	20.4 to 27.6	100	3.9	93.6	4,700	14.0 494.7	885 3.55	73	-20 to +60	40,000/60°C
9TG24P0S01				2.35	56.40	3,900	11.6 409.8	609 2.45	69	-20 to +70	
9TG48P0G01	48	36 to 55.2		1.95	93.6	4,700	14.0 494.7	885 3.55	73		

Note 1 : Fan does not rotate when PWM duty cycle is 0% .
Note 2 : Max input is 130 W at rated voltage.

*PWM Frequency : 25kHz

Other sensor specifications are available as options. Please refer to the index (p. 510).

Dimensions (unit: mm)

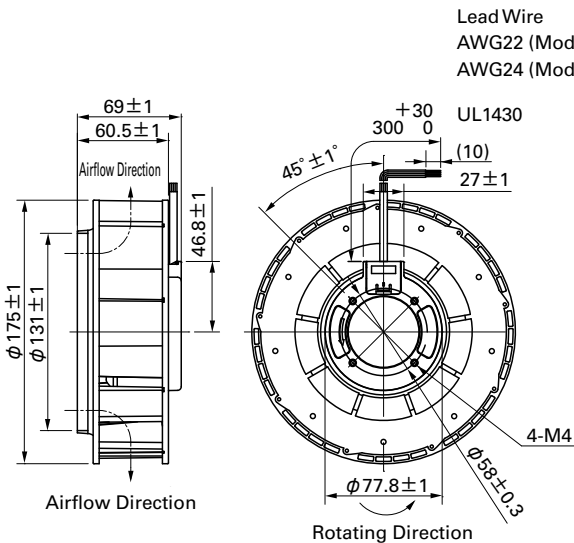

Reference Dimensions of Mounting Holes and Vent Opening (unit: mm)

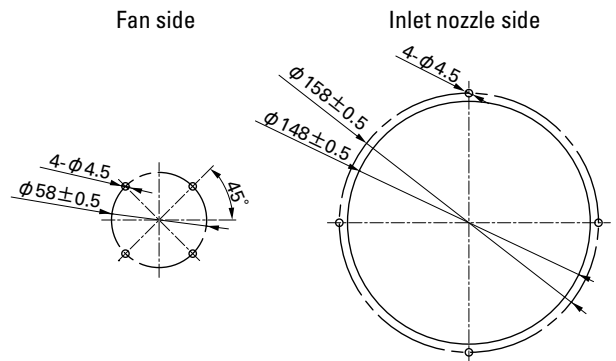

Options (unit: mm)

Inlet Nozzle

Model : 109-1073 Material : Steel sheet Surface treatment : Electro nickel plating (silver) Color : (silver)
: 109-1073H : Steel sheet : Cation electropainting (black)

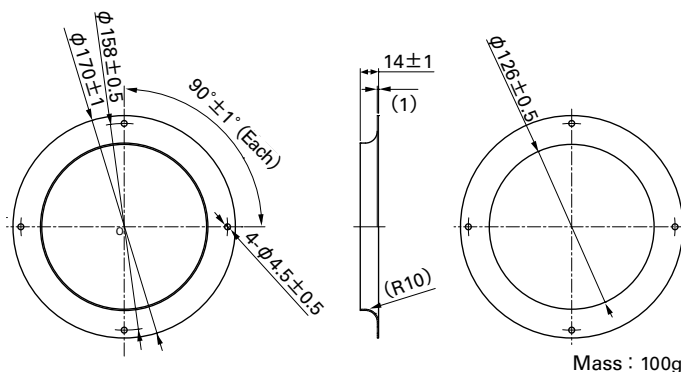

Finger Guards

Model : 109-722 Surface treatment : Nickel-chrome plating (silver) Color : (silver)

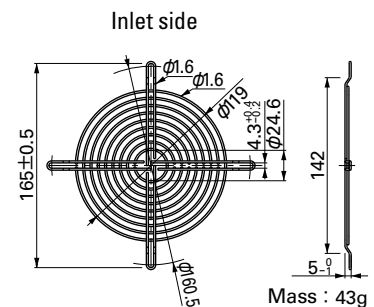

Inlet nozzle: Equipment to be mounted in inlet side for adjusting incoming airflow.

Reference Diagram for Mounting

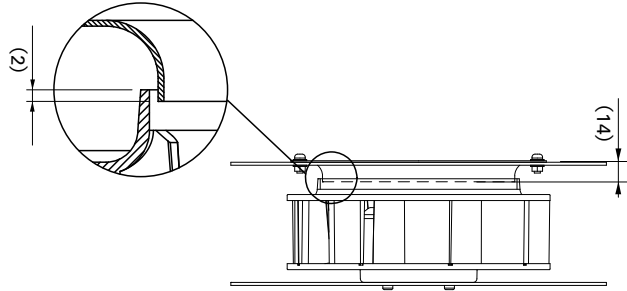
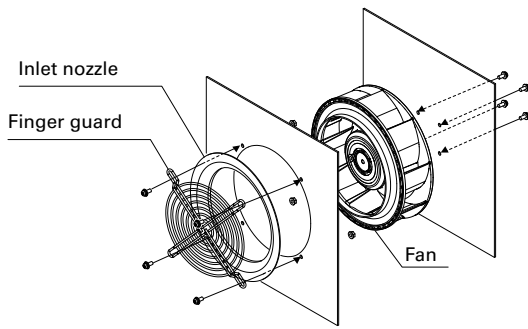

Bolt length: 4 to 6 mm.
To prevent bolts from loosening, use plain washers and spring washers.

Airflow - Static Pressure Characteristics

PWM Duty Cycle

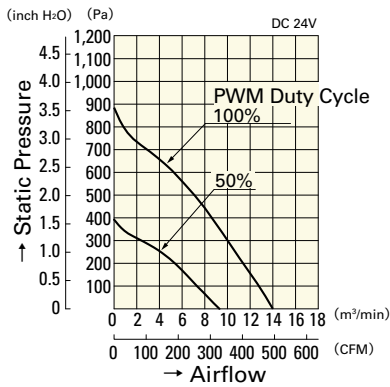

9TG24P0G01

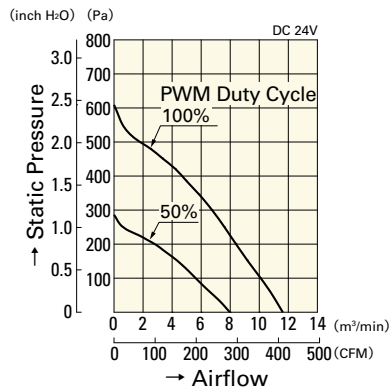

9TG24P0S01

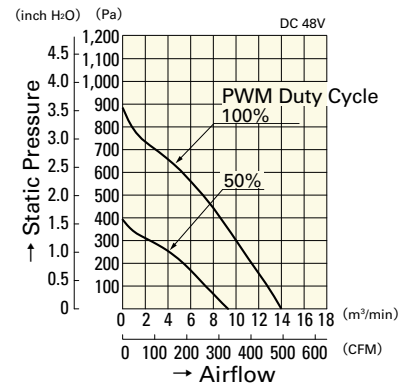

9TG48P0G01

Operating Voltage Range

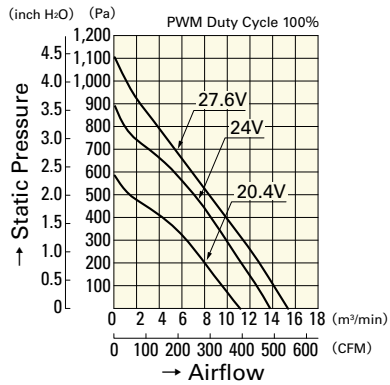

9TG24P0G01

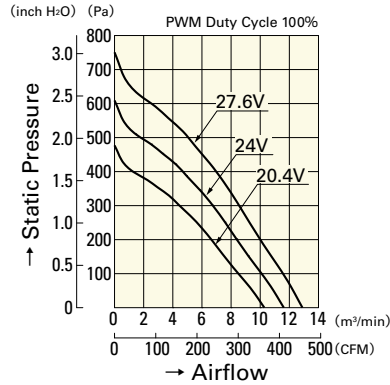

9TG24P0S01

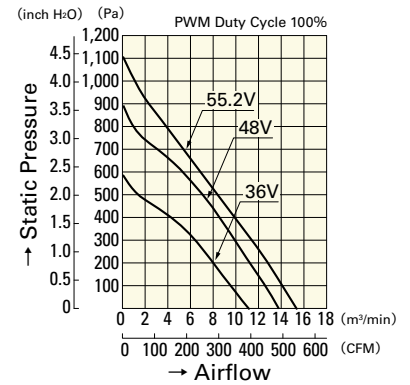

9TG48P0G01

PWM Duty - Speed Characteristics Example

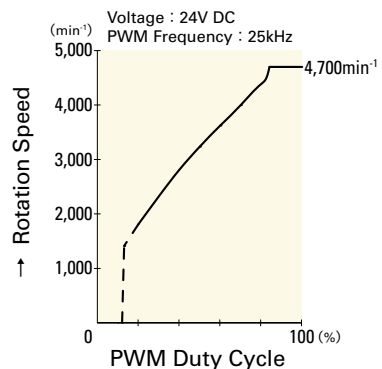

9TG24P0G01

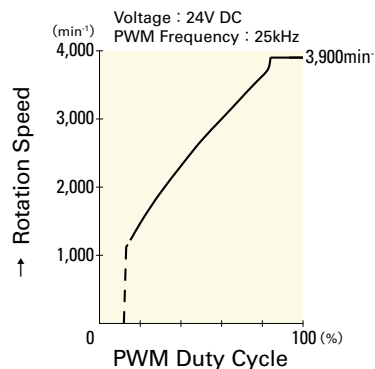

9TG24P0S01

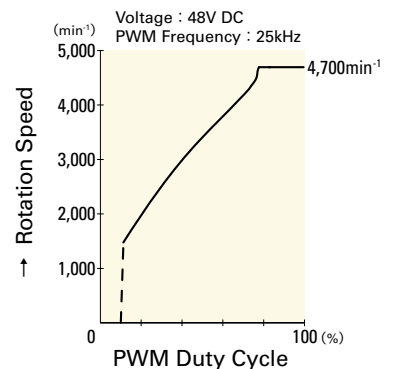

9TG48P0G01

ϕ 221mm

San Ace C221



General Specifications

- Material Motor case: Aluminum,
Impeller: Plastics (Flammability: UL94V-0)
- Expected Life Refer to specifications (L10:Survival rate: 90% at 60°C ,
rated voltage, and continuously run in a free air state)
- Lead Wire ⊕red ⊖black (Sensor) yellow (Control) brown
- Storage Temperature -30°C to +70°C (Non-condensing)

ϕ 221mm×71mm (Mass : 1,050g) **9T type**

Specifications

When inlet nozzle [Option (Model : 109-1135)] is mounted. The following nos. **have PWM controls and pulse sensors.**

Model No.	Rated Voltage [V]	Operating Voltage Range [V]	PWM duty cycle ^{*)} [%]	Rated Current [A]	Rated Input [W]	Rated Speed [min ⁻¹]	Max. Airflow [m ³ /min] [CFM]	Max. Static Pressure [Pa] [inchH ₂ O]	SPL [dB(A)]	Operating Temperature [°C]	Expected Life [h]
9TP24P0H001	24	16 to 36	100	3.2	76.8	3,050	17.6 622	530 2.13	71	-20 to +70	40,000/60°C (70,000/40°C)
			15	0.4	9.6	1,000	5.75 203	57.4 0.23	53		
9TP48P0G001	48	36 to 72	100	2.75	132	3,650	21 742	760 3.05	74	-20 to +60	
			15	0.2	9.6	1,000	5.75 203	57.4 0.23	53		
9TP48P0H001	48	36 to 72	100	1.6	76.8	3,050	17.6 622	530 2.13	71	-20 to +70	
			15	0.2	9.6	1,000	5.75 203	57.4 0.23	53		

Note 1 : Fan does not rotate when PWM duty cycle is 0%.

*)PWM Frequency : 25kHz

Note 2 : Max input of 9TP48P0G001: 280 W, 9TP24P0H001 / 9TP48P0H001: 160 W at rated voltage.

Dimensions (unit: mm)

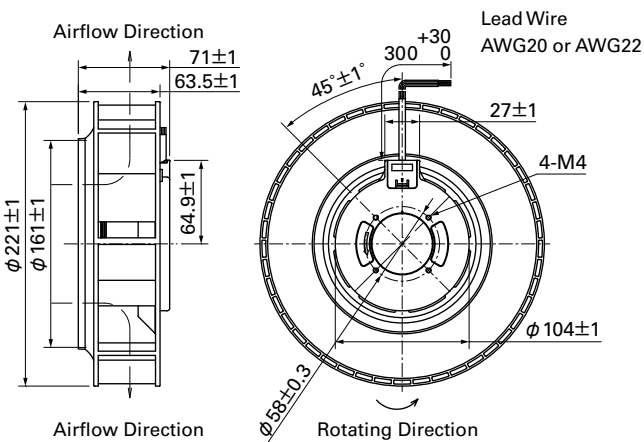

Reference Dimensions of Mounting Holes and Vent Opening (unit: mm)

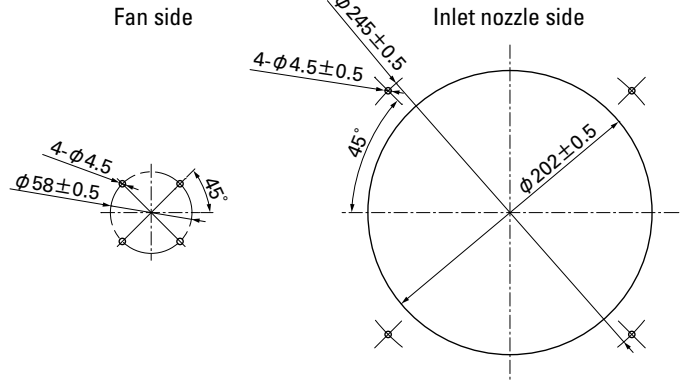

Options (unit: mm)

Inlet Nozzle

Model : 109-1135 Material : Steel sheet Surface treatment : Electro nickel plating Color (silver)

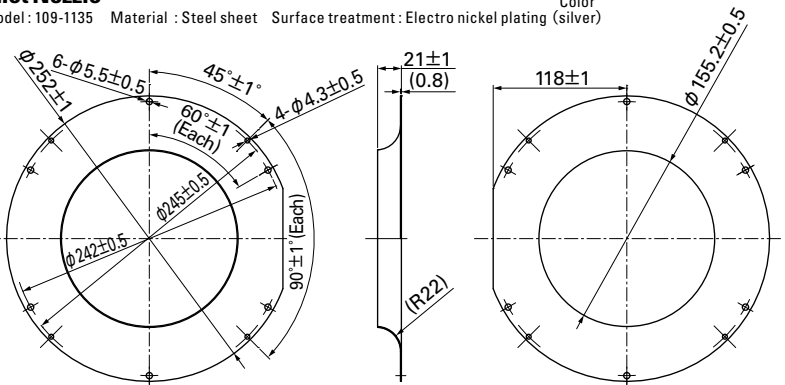

Mass: 230g

Finger Guards

Model : 109-1138 Surface treatment : Nickel-chrome plating Color (silver)

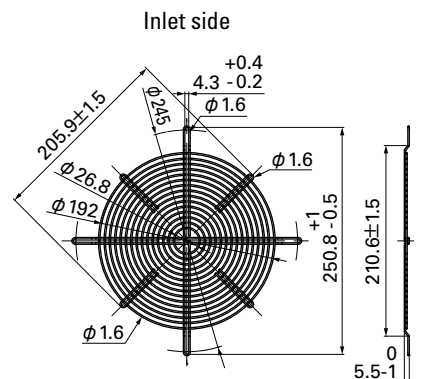

Mass: 105g

Inlet nozzle: Equipment to be mounted in inlet side for adjusting incoming airflow.

Reference Diagram for Mounting

Bracket-mounted model of this fan is available. For details, please refer to pp. 387 to 388.

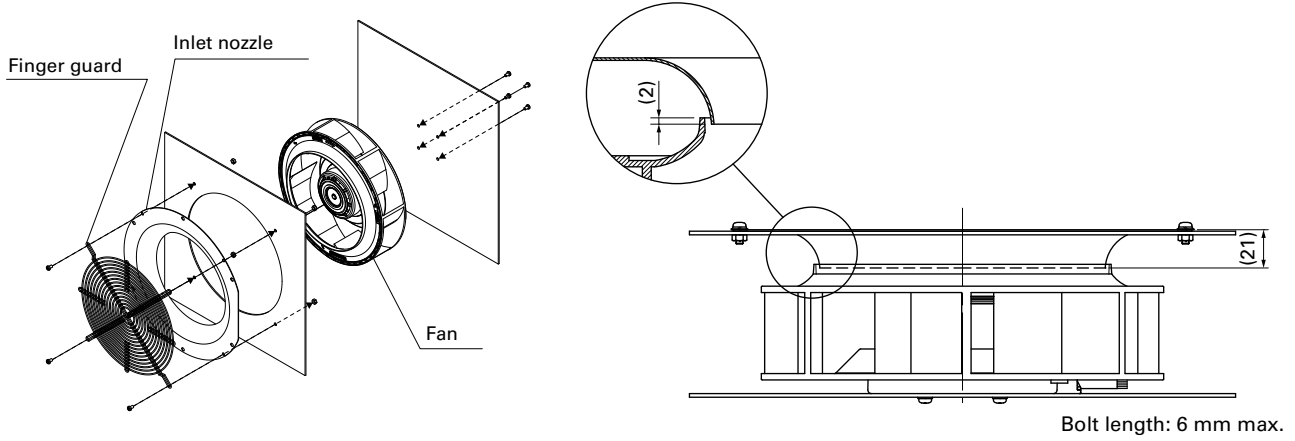

Airflow - Static Pressure Characteristics

PWM Duty Cycle

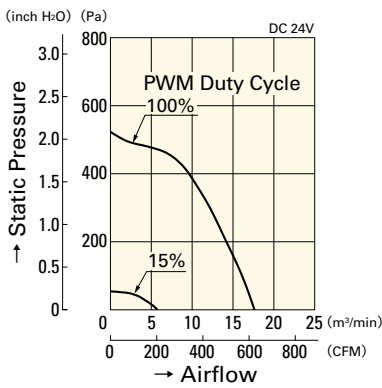

9TP24P0H001

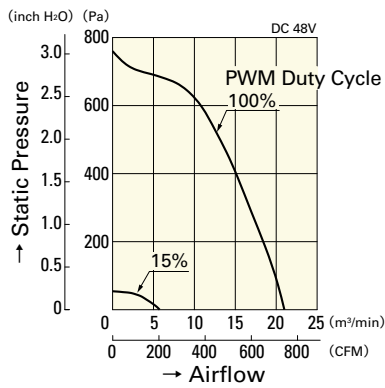

9TP48P0G001

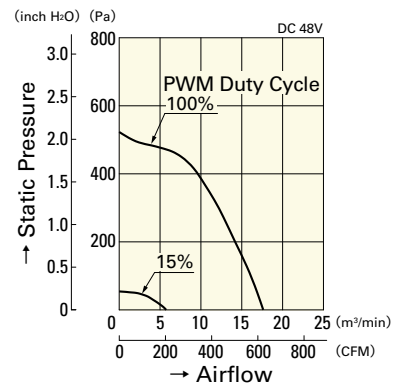

9TP48P0H001

Operating Voltage Range

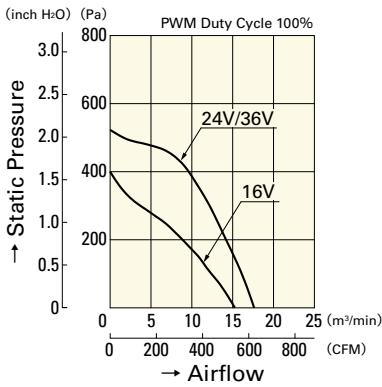

9TP24P0H001

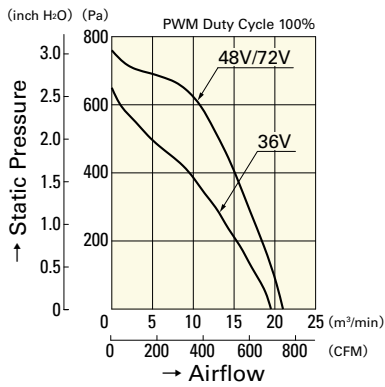

9TP48P0G001

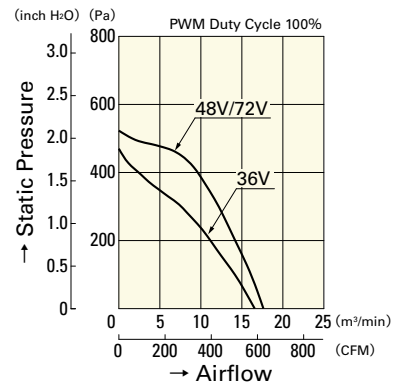

9TP48P0H001

PWM Duty - Speed Characteristics Example

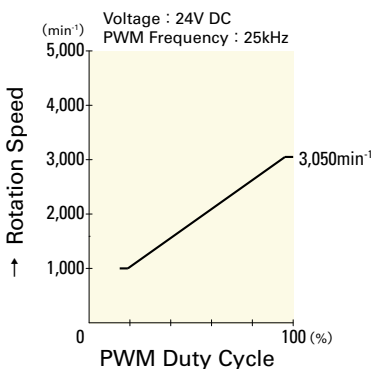

9TP24P0H001

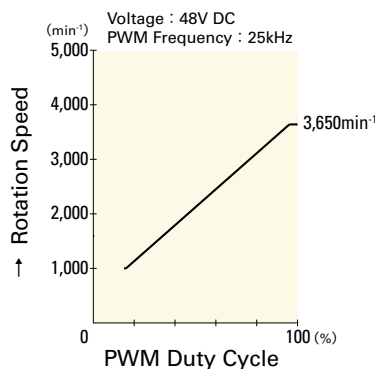

9TP48P0G001

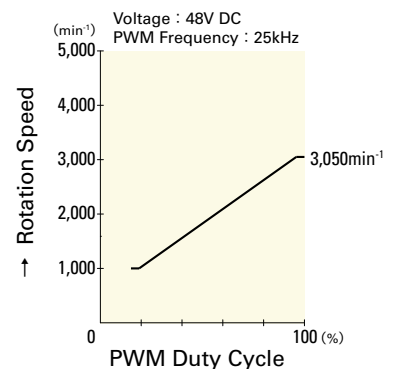

9TP48P0H001

φ 225mm

San Ace C225



General Specifications

- Material Motor case: Aluminum,
Impeller: Plastics (Flammability: UL94V-0)
- Expected Life Refer to specifications (L10:Survival rate: 90% at 60°C ,
rated voltage, and continuously run in a free air state)
- Lead Wire ⊕red ⊖black (Sensor) yellow (Control) brown
- Storage Temperature -30°C to +70°C (Non-condensing)

φ225mm×99mm (Mass : 1,220g) **9T type**

Specifications

When inlet nozzle [Option (Model : 109-1134)] is mounted. The following nos. **have PWM controls and pulse sensors.**

Model No.	Rated Voltage [V]	Operating Voltage Range [V]	PWM duty cycle _{Non(0)} [%]	Rated Current [A]	Rated Input [W]	Rated Speed [min ⁻¹]	Max. Airflow [m ³ /min] [CFM]	Max. Static Pressure [Pa] [inchH ₂ O]	SPL [dB(A)]	Operating Temperature [°C]	Expected Life [h]
9TS48P0G001	48	36 to 72	100	3.65	175.2	3,550	28.1 992	861 3.46	74.5	-20 to +60	40,000/60°C (70,000/40°C)
			15	0.24	11.5	1,000	7.85 277	68.5 0.28	52.0		
9TS48P0H001			100	2.08	99.8	2,900	22.7 802	590 2.37	70.5	-20 to +70	
			15	0.24	11.5	1,000	7.85 277	68.5 0.28	52.0		

Note 1 : Fan does not rotate when PWM duty cycle is 0% .

※PWM Frequency : 25kHz

Note 2 : Max input of 9TS48P0G001: 380 W, 9TS48P0H001: 200 W at rated voltage.

Dimensions (unit: mm)

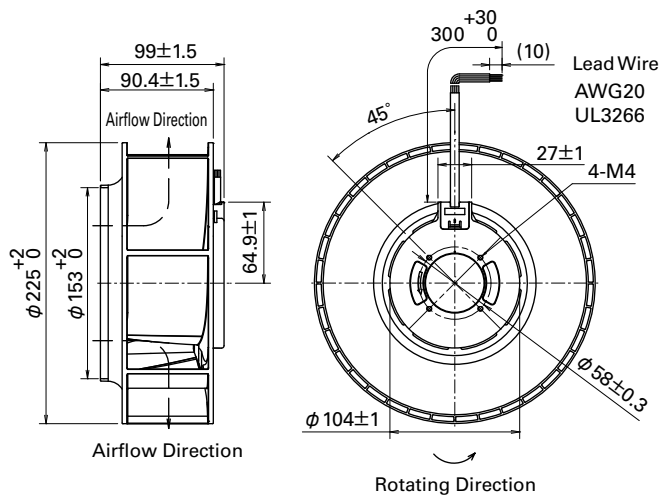

Reference Dimensions of Mounting Holes and Vent Opening (unit: mm)

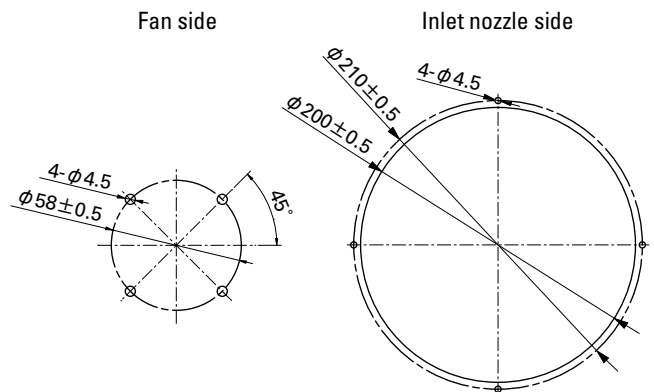

Options (unit: mm)

Inlet Nozzle

Model : 109-1134 Material : Steel sheet Surface treatment : Electro nickel plating (silver) Color (silver)

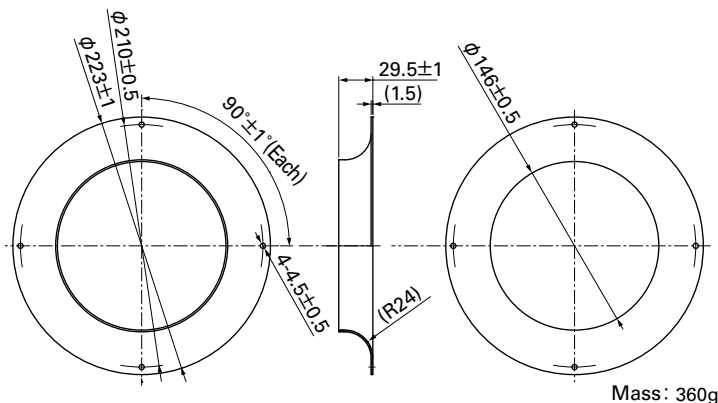

Finger Guards

Model : 109-1137 Surface treatment : Nickel-chrome plating (silver) Color (silver)

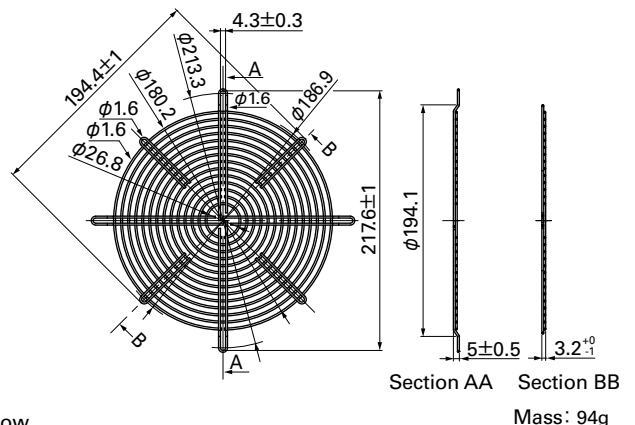

Inlet nozzle: Equipment to be mounted in inlet side for adjusting incoming airflow.

Reference Diagram for Mounting

Bracket-mounted model of this fan is available. For details, please refer to pp. 389 to 390.

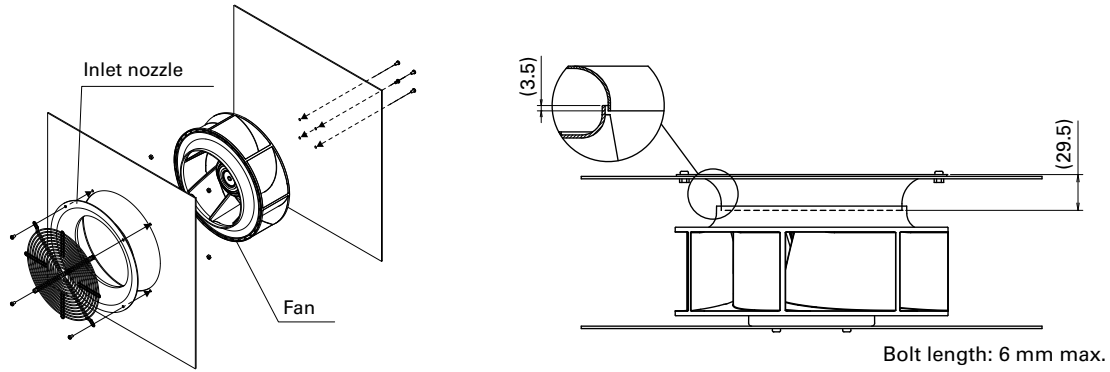

Airflow - Static Pressure Characteristics

PWM Duty Cycle

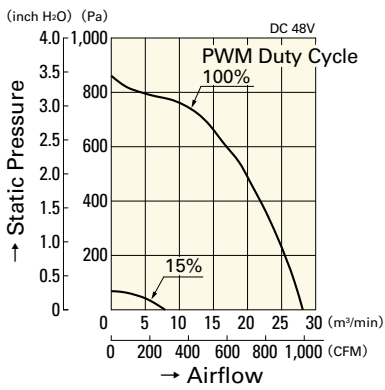

9TS48P0G001

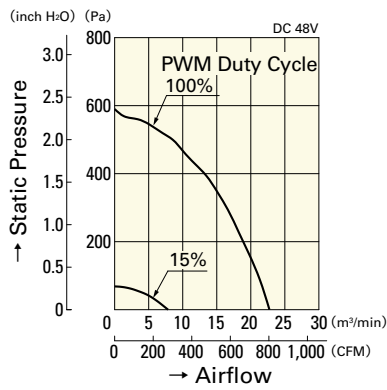

9TS48P0H001

Operating Voltage Range

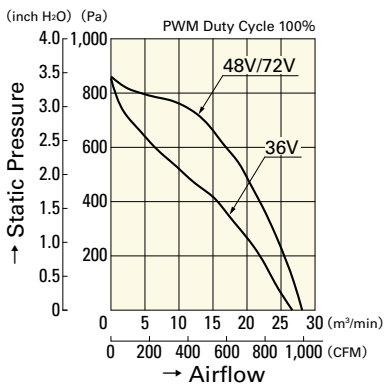

9TS48P0G001

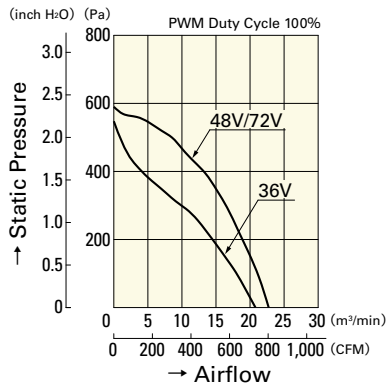

9TS48P0H001

PWM Duty - Speed Characteristics Example

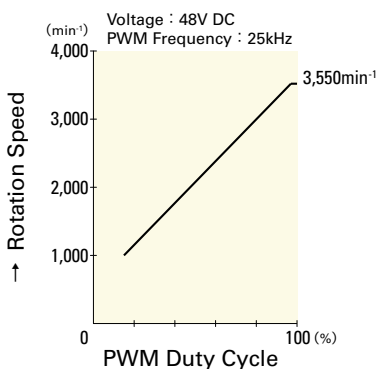

9TS48P0G001

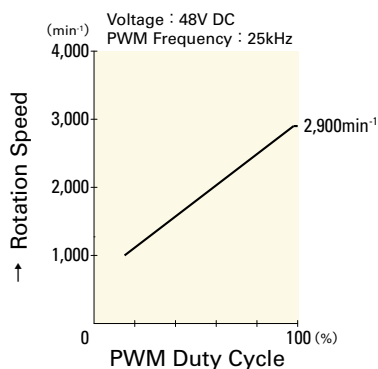

9TS48P0H001

270mm sq.

San Ace C270



General Specifications

- Material Motor case: Aluminum,
Impeller: Plastics (Flammability: UL94V-0)
Bracket: Aluminum, Plastics (Flammability: UL94V-0)
- Expected Life Refer to specifications (L10:Survival rate: 90% at 60°C ,
rated voltage, and continuously run in a free air state)
- Lead Wire ⊕red ⊖black (Sensor) yellow (Control) brown
- Storage Temperature -30°C to +70°C (Non-condensing)

270mm×270mm×99mm (Mass : 1,700g) **9B1T type**

Specifications

The following nos. **have PWM controls and pulse sensors.**

Model No.	Rated Voltage [V]	Operating Voltage Range [V]	PWM duty cycle _{Non(0%)} [%]	Rated Current [A]	Rated Input [W]	Rated Speed [min ⁻¹]	Max. Airflow [m ³ /min] [CFM]	Max. Static Pressure [Pa] [inchH ₂ O]	SPL [dB(A)]	Operating Temperature [°C]	Expected Life [h]
9B1TP24P0H001	24	16 to 36	100	3.2	76.8	3,050	17.6 622	530 2.13	71	-20 to +70	40,000/60°C (70,000/40°C)
			15	0.4	9.6	1,000	5.75 203	57.4 0.23	53		
9B1TP48P0G001	48	36 to 72	100	2.75	132	3,650	21.0 742	760 3.05	74	-20 to +60	
			15	0.2	9.6	1,000	5.75 203	57.4 0.23	53		
9B1TP48P0H001			100	1.6	76.8	3,050	17.6 622	530 2.13	71	-20 to +70	
			15	0.2	9.6	1,000	5.75 203	57.4 0.23	53		

Note 1 : Fan does not rotate when PWM duty cycle is 0% .

※PWM Frequency : 25kHz

Note 2 : Max input of 9B1TP24P0H001/9B1TP48P0H001 : 160W. 9B1TP48P0G001 : 280W at rated voltage.

Dimensions (unit: mm)

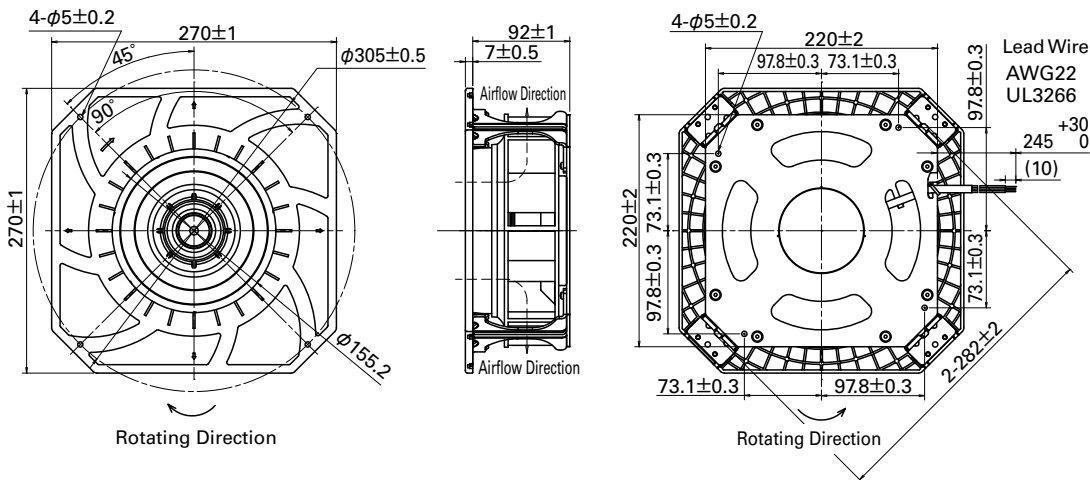

Reference Dimensions of Mounting Holes and Opening (unit: mm)

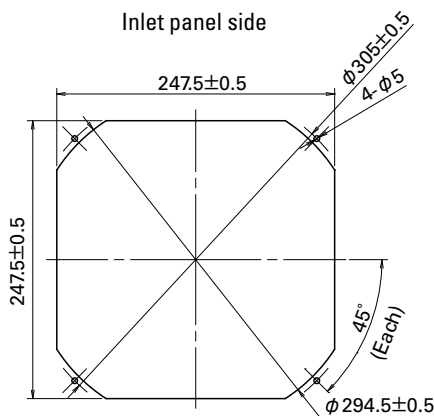

Options (unit: mm)

Finger Guards

Model : 109-1146 Surface treatment : Nickel-chrome plating (silver) Color

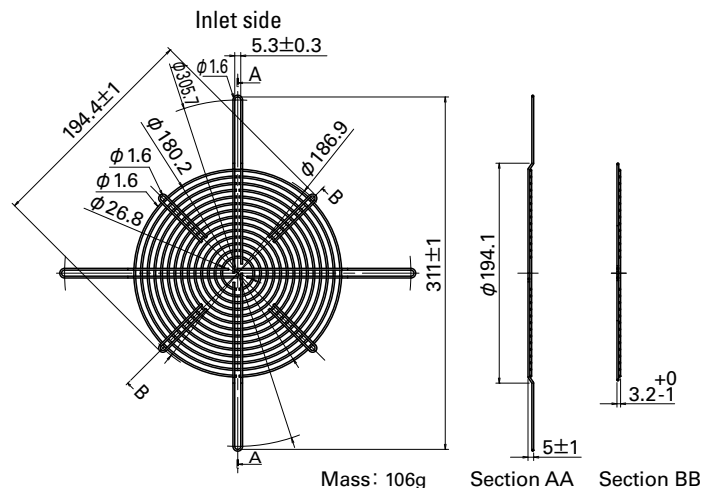

Reference Diagram for Mounting

Finger guard 109-1146 should be mounted with four holes as in the drawing.

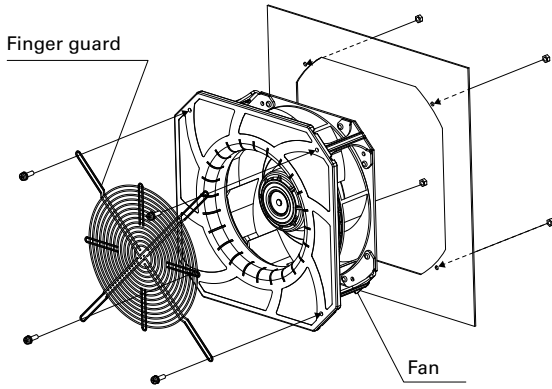

Airflow - Static Pressure Characteristics

PWM Duty Cycle

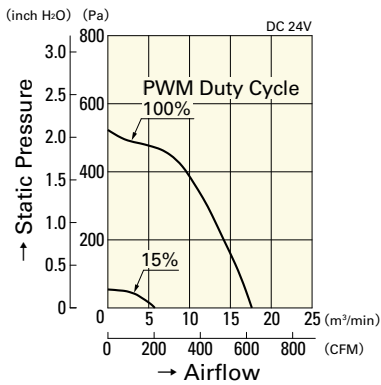

9B1TP24P0H001

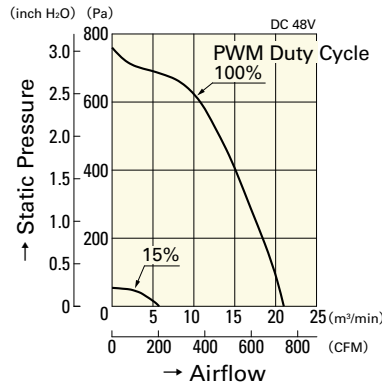

9B1TP48P0G001

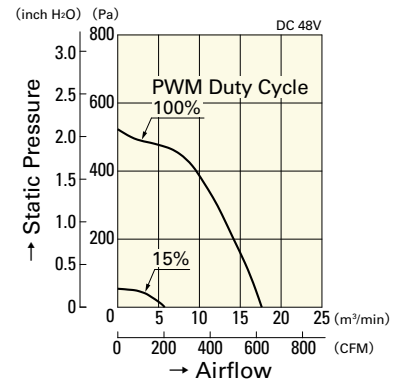

9B1TP48P0H001

Operating Voltage Range

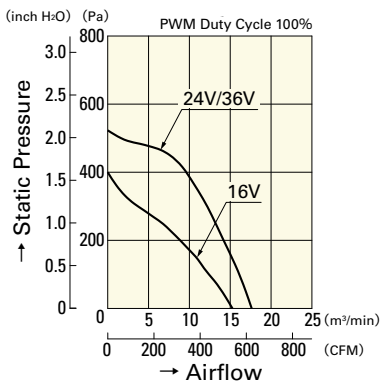

9B1TP24P0H001

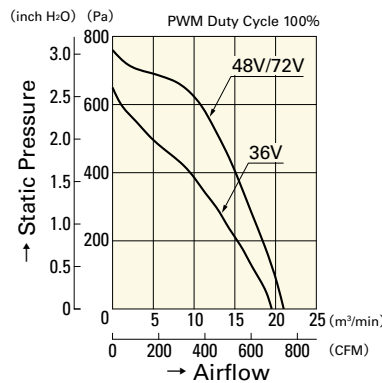

9B1TP48P0G001

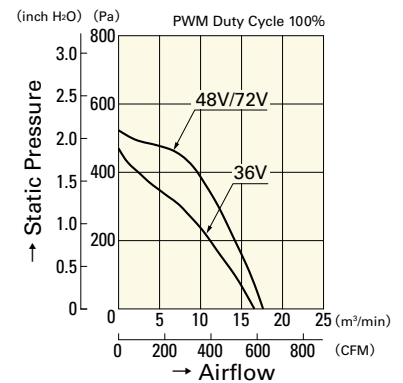

9B1TP48P0H001

PWM Duty - Speed Characteristics Example

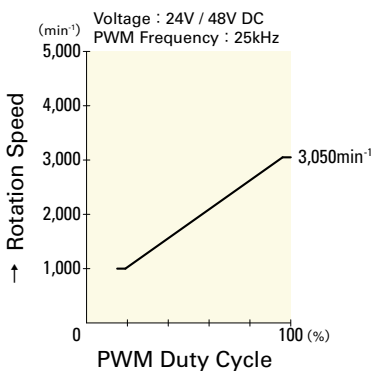

9B1TP24P0H001
9B1TP48P0H001

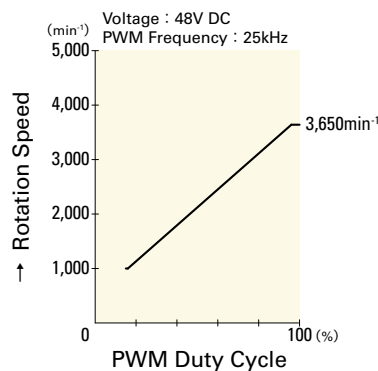

9B1TP48P0G001

270mm sq.

San Ace C270



General Specifications

- Material Motor case: Aluminum,
Impeller: Plastics (Flammability: UL94V-0)
Bracket: Aluminum, Plastics (Flammability: UL94V-0)
- Expected Life Refer to specifications (L10:Survival rate: 90% at 60°C ,
rated voltage, and continuously run in a free air state)
- Lead Wire ⊕red ⊖black (Sensor) yellow (Control) brown
- Storage Temperature -30°C to +70°C (Non-condensing)

270mm×270mm×119mm (Mass : 1,920g) **9B1T type**

Specifications

The following nos. have PWM controls and pulse sensors.

Model No.	Rated Voltage [V]	Operating Voltage Range [V]	PWM duty cycle _{Non(0)} [%]	Rated Current [A]	Rated Input [W]	Rated Speed [min ⁻¹]	Max. Airflow [m ³ /min] [CFM]	Max. Static Pressure [Pa] [inchH ₂ O]	SPL [dB(A)]	Operating Temperature [°C]	Expected Life [h]
9B1TS48P0G001	48	36 to 72	100	3.65	175.2	3,550	28.1 992	861 3.46	74.5	-20 to +60	40,000/60°C (70,000/40°C)
			15	0.24	11.5	1,000	7.85 277	68.5 0.28	52.0		
9B1TS48P0H001			100	2.08	99.8	2,900	22.7 802	590 2.37	70.5	-20 to +70	
			15	0.24	11.5	1,000	7.85 277	68.5 0.28	52.0		

Note 1 : Fan does not rotate when PWM duty cycle is 0% .

※PWM Frequency : 25kHz

Note 2 : Max input of 9B1TS48P0G001 : 380W, 9B1TS48P0H001 : 200W at rated voltage.

Dimensions (unit: mm)

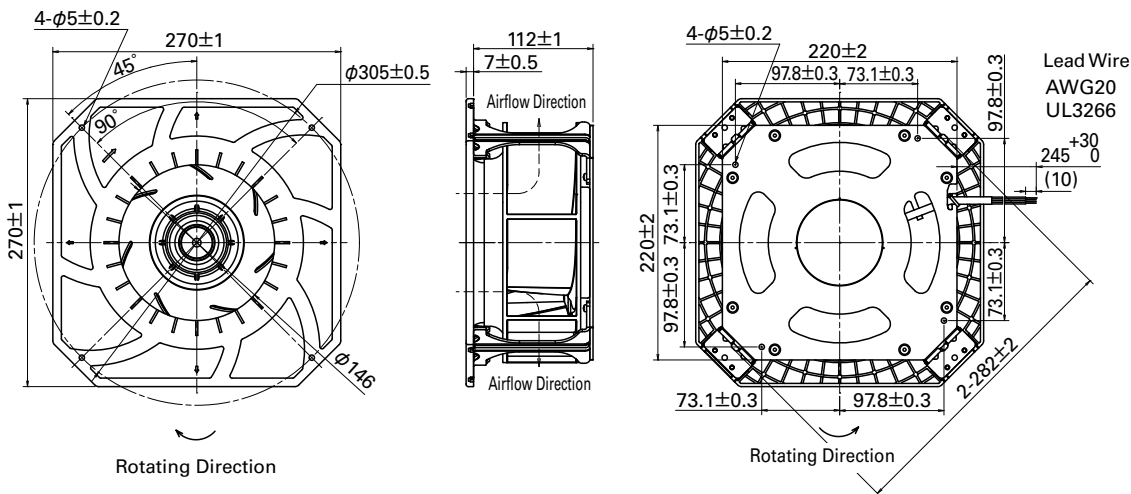

Reference Dimensions of Mounting Holes and Opening (unit: mm)

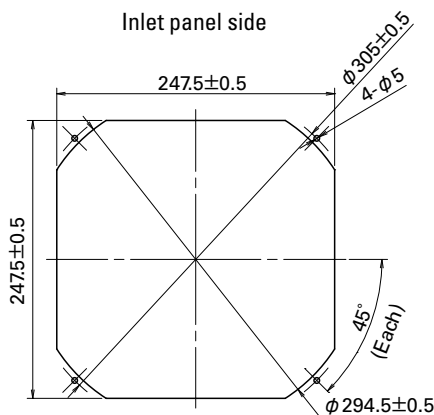

Options (unit: mm)

Finger Guards

Model : 109-1146 Surface treatment : Nickel-chrome plating (silver)

Color

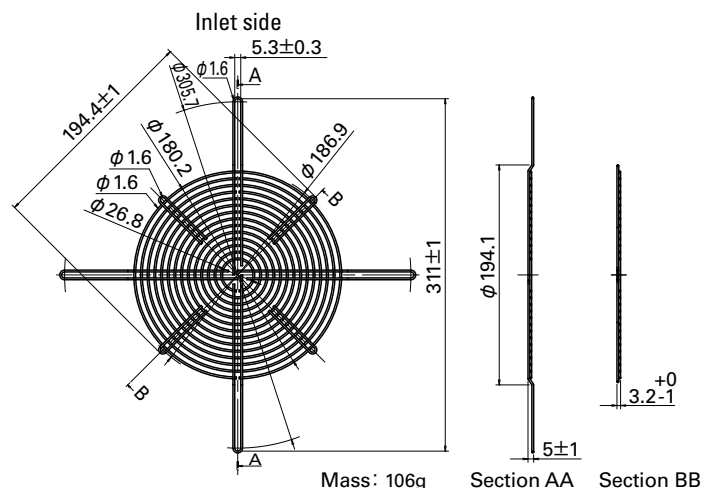

Reference Diagram for Mounting

Finger guard 109-1146 should be mounted with four holes as in the drawing.

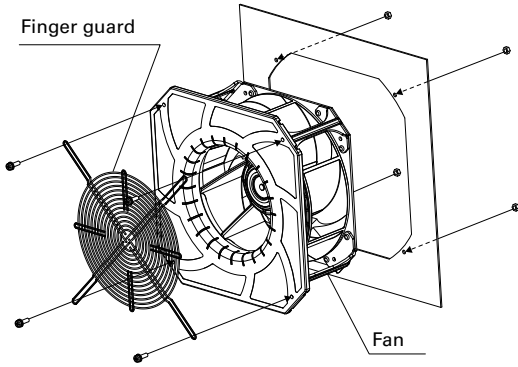

Airflow - Static Pressure Characteristics

PWM Duty Cycle

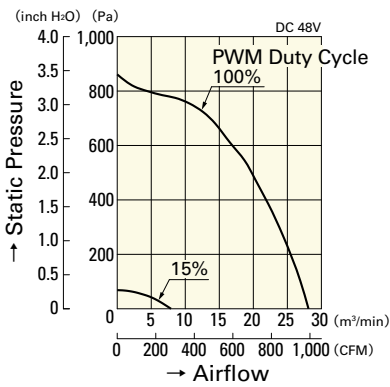

9B1TS48P0G001

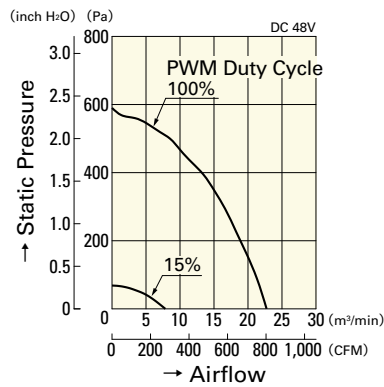

9B1TS48P0H001

Operating Voltage Range

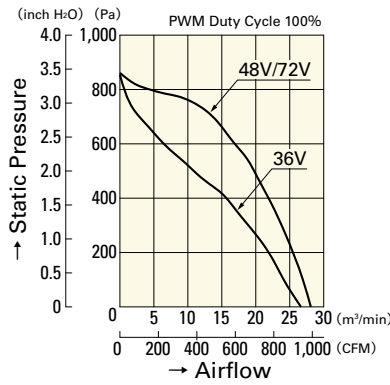

9B1TS48P0G001

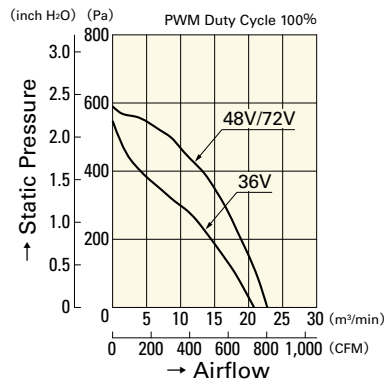

9B1TS48P0H001

PWM Duty - Speed Characteristics Example

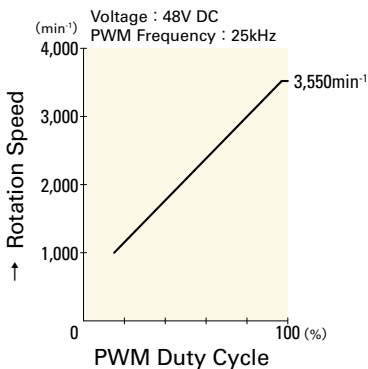

9B1TS48P0G001

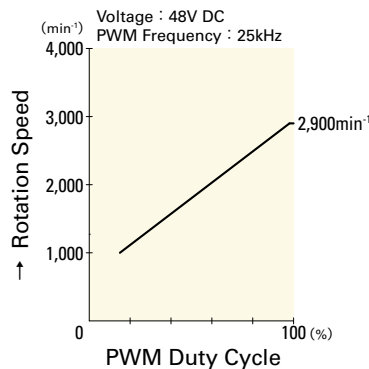

9B1TS48P0H001

Blower

Cooling fan specialized for high static pressure

Domain Diagram

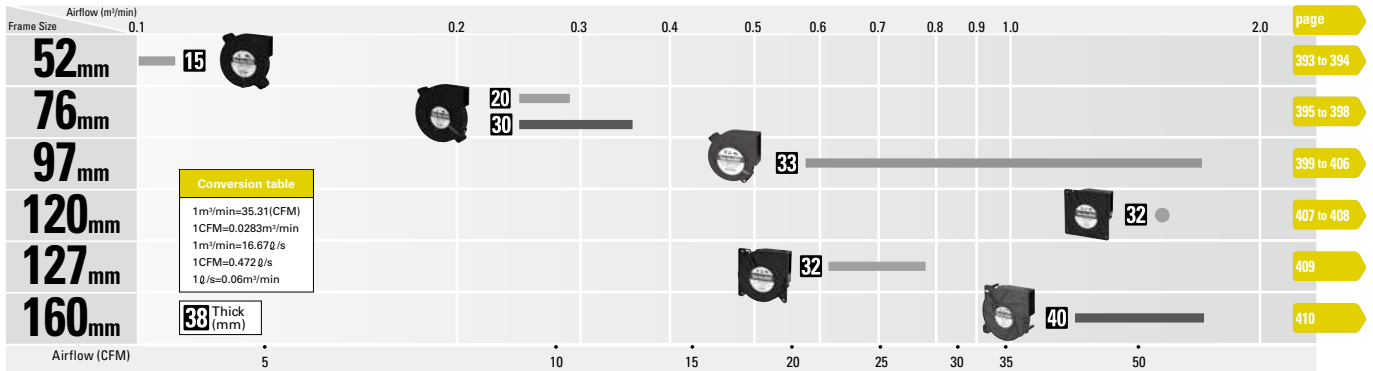

Model Numbering System

Not every combination of the following codes or characters is available. Contact us for an available combination.

109B	C	12	H	C	2	-1
Type name / frame material 109B / Plastics 9B / Plastics	Frame size C : 52mm F : 120mm D : 76mm J : 127mm M : 97mm G : 160mm	Voltage 12 : 12V 24 : 24V etc	Speed code F,G,H,K,M,S etc	Sensor specifications A : Without a sensor C : With a pulse sensor D : With a lock sensor	Frame thickness 1 : 40mm thick 2 : 30mm thick, 32mm thick, 33mm thick 7 : 15mm thick 6 : 20mm thick	Individual customer's spec

9B	MB	12	G	2	01	-1
Type name / frame material 9B / Plastics	Frame size MB : 97mm FB : 120mm	Voltage 12 : 12V 24 : 24V	Speed code G / S / H etc	Frame thickness 2 : 32mm thick / 33mm thick	Sensor specifications 01 : With a pulse sensor 02 : Without a sensor	Individual customer's spec

Fans with PWM control function

Example :

9B	MB	12	P	2	G	01
Type name / frame material 9B / Plastics	Frame size MB : 97mm FB : 120mm	Voltage 12 : 12V	PWM control function	Frame thickness 2 : 32mm thick / 33mm thick	Speed code	Individual customer's spec 2 or 3 digits

How to Read Specifications

DC Fan											DC	
Model No.	① Rated Voltage [V]	② Operating Voltage Range [V]	③ Rated Current [A]	④ Rated Input [W]	⑤ Rated Speed [min ⁻¹]	⑥ Max. Airflow [m ³ /min] [CFM]		⑦ Max. Static Pressure [Pa] [inchH ₂ O]		⑧ SPL [dB(A)]	⑨ Operating Temperature [°C]	⑩ Expected Life [h]
9GA0412G7001	12	7 to 13.8	0.17	2.04	13,100	0.36	12.7	192	0.77	42	-20 to +70	40,000/60°C (70,000/40°C)

- ① Rated Voltage This is the necessary voltage to drive the fan. 12VDC, 24VDC and 48VDC are available.
- ② Operating Voltage Range... The voltage range over which fan operation is guaranteed
- ③ Rated Current The current value during the fan's rated operation without load
- ④ Rated Input The input value during the fan's rated operation without load
- ⑤ Rated Speed The rotating speed during the fan's rated operation without load
- ⑥ Max. Airflow The maximum air volume that the fan can output during rated operation (according to the company's dual-chamber device).
The volume of air generated by the fan in a given time period
- ⑦ Max. Static Pressure The maximum static pressure value that the fan can output during rated operation (according to the company's dual-chamber device). The static pressure is the fan's force to propel air by overcoming the resistance of the device that uses the fan when it propels air.
- ⑧ SPL "SPL" is Sound Pressure Level. The noise level during the fan's rated operation.
Please refer to the technical material section for the method used to measure the noise level.
- ⑨ Operating Temperature The temperature range over which fan operation is guaranteed (Non- condensing)
- ⑩ Expected Life The fan's expected operating life when the fan operates continuously at the rated voltage at a temperature of 60°C and at relative humidity of 90%. Expected life at 40°C ambient is just reference value.
Please refer to the technical material section for the expected operating life.

DC Fan Common Specifications

Material Frame,Impeller:Plastics / Frame:Aluminum,Impeller:Plastics

* For details, refer to the appropriate page.

Expected LifeVaries for each model (L10:Survival rate:90% at 60°C ,rated voltage, and continuously run in a free air state)

* Splash proof fan: Varies for each model (Indoor, L10:Survival rate:90% at 60°C ,rated voltage, and continuously run in a free air state)

Motor Protection Burnout protection at locked rotor condition and Reverse polarity protection

Dielectric StrengthAC50/60Hz 500VAC 1minute(between lead conductor and frame)

Insulation Resistance10M Ω or more at 500VDC megger (between lead conductor and frame)

Sound Pressure Level(SPL) ..Expressed as the value at 1m from air inlet side

Lead WireFor details, refer to the appropriate page.

Overheating protection function

Protection Functions:

If the fan blades are restricted, an overcurrent occurs and leads to a rise in the fan coil temperature. This can result in reduced performance, damage, or a fire. To prevent this from occurring, SANYO DENKI's fans incorporate an overheating protection function. Refer to the catalog for the types of protection functions.

Burnout protection function at locked rotor condition

- Current cutoff system

If the fan blades are restricted, the coil current is cut off at regular cycles to prevent overheating of the coil. When the hindrance is removed, the fan restarts automatically.

Reverse polarity protection function

No problem about fan even if positive & negative lead are connected in reverse.

However, when wiring fans with sensors or PWM speed control function, connecting positive and negative leads in reverse may damage the fans.

52mm**San Ace B52****General Specifications**

- Material Frame: Plastics (Flammability: UL94V-0),
Impeller: Plastics (Flammability: UL94V-0)
- Expected Life Refer to specifications (L10:Survival rate: 90% at 60°C ,
rated voltage, and continuously run in a free air state)
- Lead Wire ⊕red ⊖black (Sensor) yellow
- Storage Temperature -30°C to +70°C (Non-condensing)

52mm × 15mm [Mass : 33g] **9BC type****Specifications** The following nos. **have pulse sensors.**

Model No.	Rated Voltage [V]	Operating Voltage Range [V]	Rated Current [A]	Rated Input [W]	Rated Speed [min ⁻¹]	Max. Airflow [m ³ /min] [CFM]	Max. Static Pressure [Pa] [inchH ₂ O]	SPL [dB(A)]	Operating Temperature [°C]	Expected Life [h]
109BC12GC7-1	12	6 to 13.8	0.12	1.44	6,200	0.125 4.4	215 0.86	43	-20 to +70	40,000/60°C (70,000/40°C)
109BC12HC7-1			0.10	1.20	5,600	0.112 4.0	165 0.66	40		
109BC12FC7-1			0.08	0.96	5,100	0.101 3.6	130 0.52	38		
109BC12MC7-1			0.06	0.72	4,600	0.091 3.2	100 0.40	35		
109BC24GC7-1	24	12 to 27.6	0.07	1.68	6,200	0.125 4.4	215 0.86	43		
109BC24HC7-1			0.05	1.20	5,600	0.112 4.0	165 0.66	40		
109BC24FC7-1			0.04	0.96	5,100	0.101 3.6	130 0.52	38		

Other sensor specifications are available as options. Please refer to the index (p. 495).

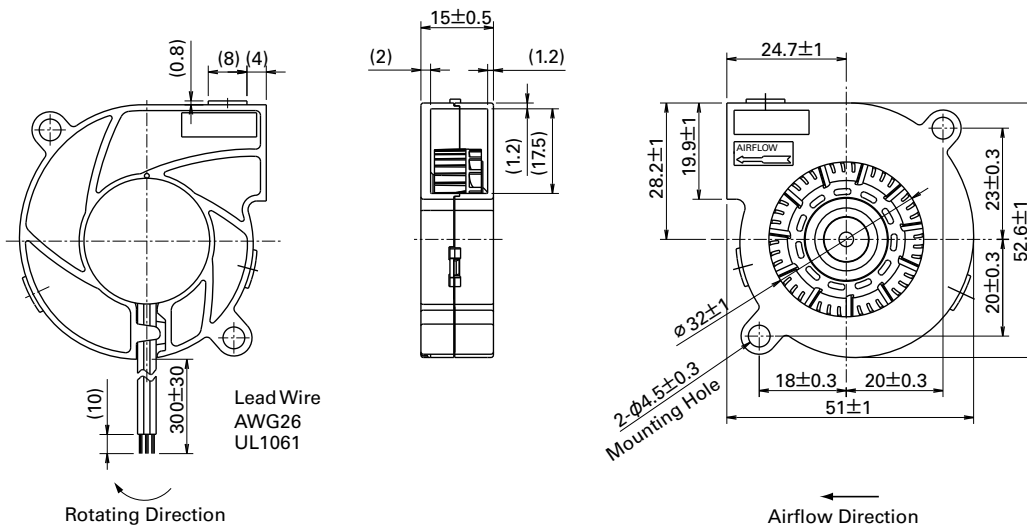
Dimensions (unit: mm)

Airflow - Static Pressure Characteristics

G speed

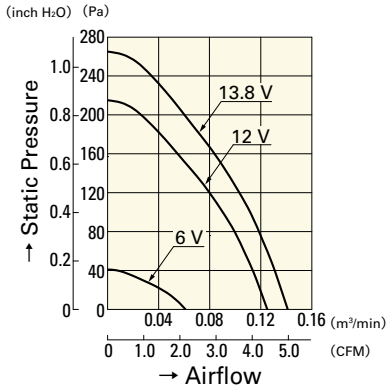

109BC12GC7-1

H speed

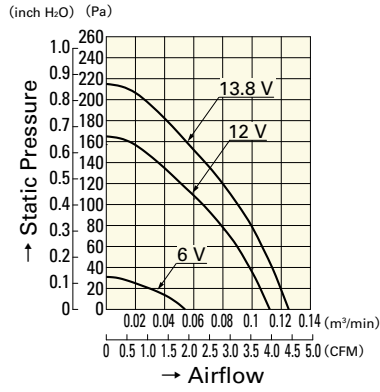

109BC12HC7-1

F speed

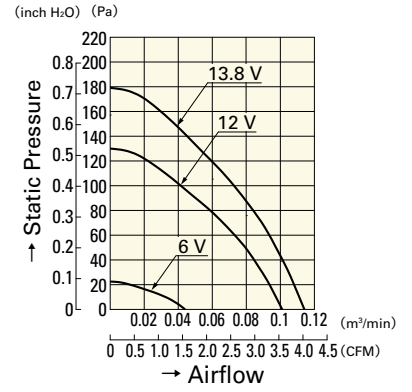

109BC12FC7-1

M speed

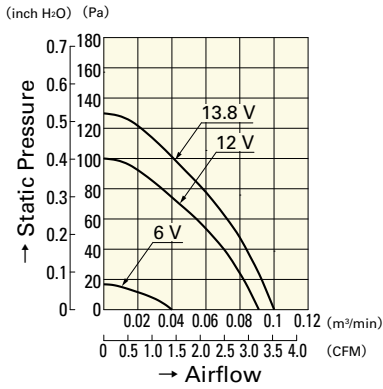

109BC12MC7-1

G speed

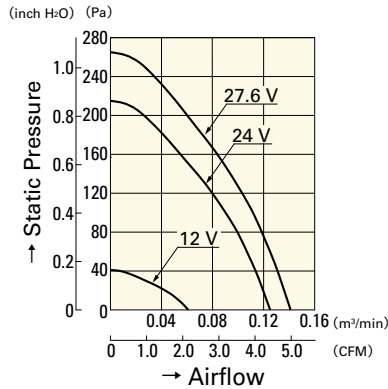

109BC24GC7-1

H speed

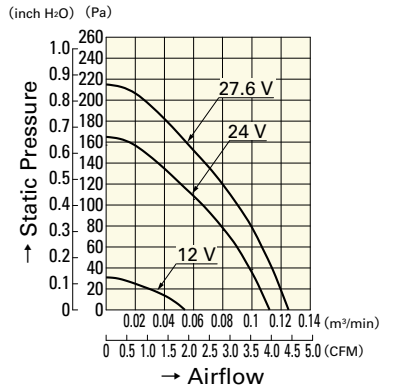

109BC24HC7-1

F speed

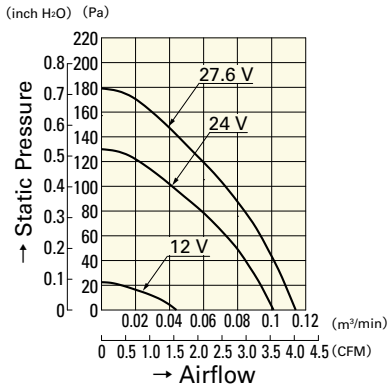

109BC24FC7-1

DC

Blower 52mm

76_{mm}

San Ace B76



General Specifications

- Material Frame: Plastics (Flammability: UL94V-0),
Impeller: Plastics (Flammability: UL94V-0)
- Expected Life Refer to specifications (L10:Survival rate: 90% at 60°C ,
rated voltage, and continuously run in a free air state)
- Lead Wire ⊕red ⊖black (Sensor) yellow
- Storage Temperature -30°C to +70°C (Non-condensing)

76mm×20mm (Mass : 58g) **9BD type**Specifications The following nos. **have pulse sensors.**

Model No.	Rated Voltage [V]	Operating Voltage Range [V]	Rated Current [A]	Rated Input [W]	Rated Speed [min ⁻¹]	Max. Airflow [m ³ /min] [CFM]	Max. Static Pressure [Pa] [inchH ₂ O]	SPL [dB(A)]	Operating Temperature [°C]	Expected Life [h]
9BD12SC6-1	12	5 to 13.8	0.28	3.36	4,500	0.29 10.2	300 1.20	43	-20 to +70	40,000/60°C (70,000/40°C)
9BD12HC6-1			0.21	2.52	4,200	0.27 9.5	230 0.92	41		
9BD12FC6-1		5.5 to 13.8	0.18	2.16	3,900	0.25 8.8	200 0.80	39		
9BD24SC6-1	24	10 to 27.6	0.14	3.36	4,500	0.29 10.2	300 1.20	43		
9BD24HC6-1			0.12	2.88	4,200	0.27 9.5	230 0.92	41		
9BD24FC6-1			0.10	2.4	3,900	0.25 8.8	200 0.80	39		

Other sensor specifications are available as options. Please refer to the index (p. 500).

Dimensions (unit: mm)

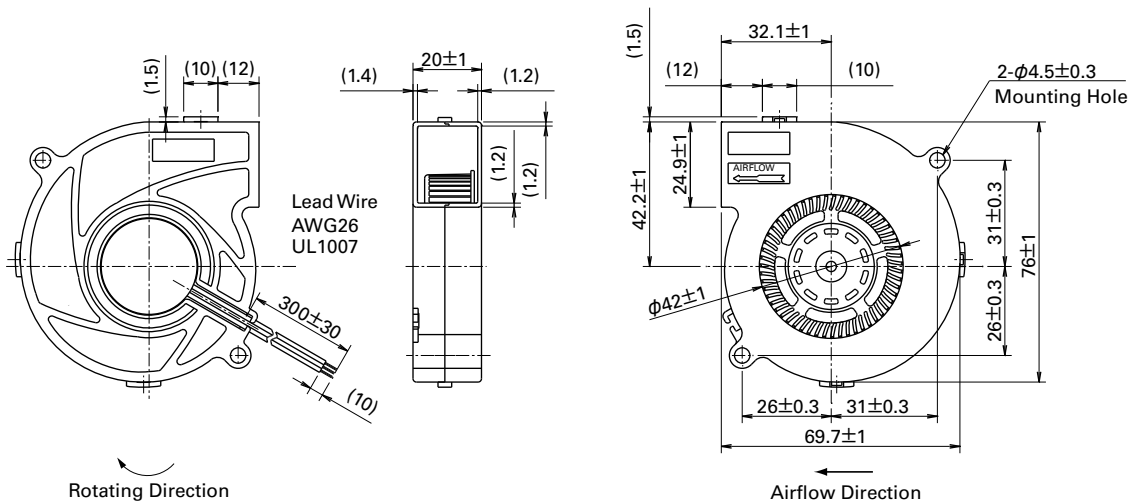

Airflow - Static Pressure Characteristics

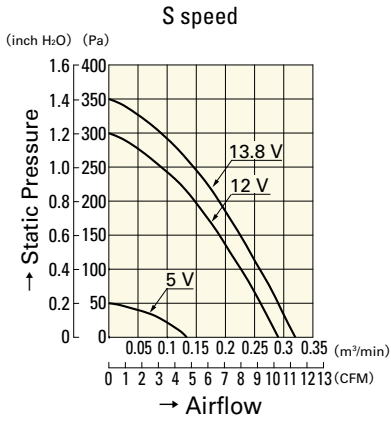

9BD12SC6-1

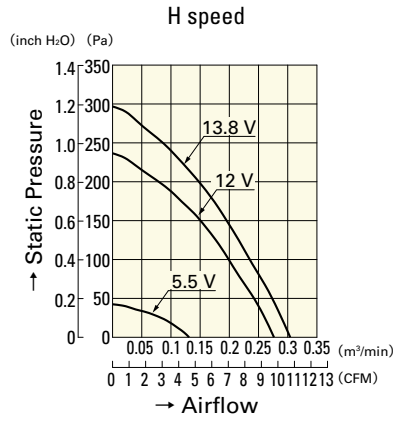

9BD12HC6-1

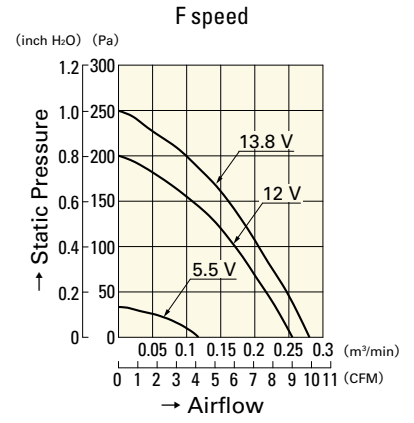

9BD12FC6-1

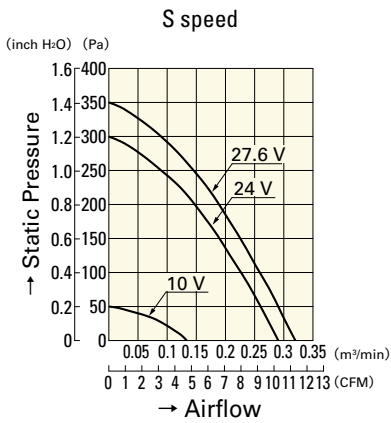

9BD24SC6-1

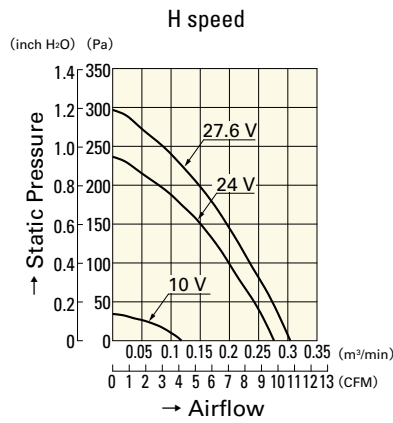

9BD24HC6-1

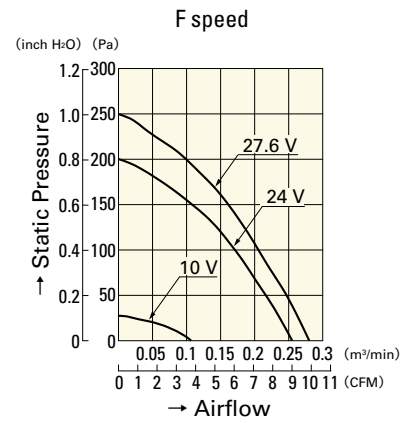

9BD24FC6-1

DC

Blower 76mm

76_{mm}

San Ace B76



General Specifications

- Material Frame: Plastics (Flammability: UL94V-0),
Impeller: Plastics (Flammability: UL94V-1)
- Expected Life Refer to specifications (L10:Survival rate: 90% at 60°C,
rated voltage, and continuously run in a free air state)
- Lead Wire ⊕red ⊖black or blue (Sensor) yellow
- Storage Temperature -30°C to +70°C (Non-condensing)

76mm×30mm (Mass : 100g) **9BD type**

Specifications The following nos. have pulse sensors.

Model No.	Rated Voltage [V]	Operating Voltage Range [V]	Rated Current [A]	Rated Input [W]	Rated Speed [min ⁻¹]	Max. Airflow [m ³ /min] [CFM]	Max. Static Pressure [Pa] [inchH ₂ O]	SPL [dB(A)]	Operating Temperature [°C]	Expected Life [h]
109BD12HC2	12	10.2 to 13.8	0.37	4.44	3,000	0.36 12.7	151.9 0.610	41.5	-20 to +60	40,000/60°C
109BD12FC2			0.27	3.24	2,600	0.31 10.9	98 0.394	37		
109BD12MC2			0.14	1.68	2,100	0.25 8.8	58.8 0.236	32.5		
109BD24HC2	24	20.4 to 27.6	0.17	4.08	3,000	0.36 12.7	151.9 0.610	41.5	-20 to +60	
109BD24FC2			0.14	3.36	2,600	0.31 10.9	98 0.394	37	-20 to +70	
109BD24MC2			0.10	2.40	2,100	0.25 8.8	58.8 0.236	32.5	-20 to +70	

Other sensor specifications are available as options. Please refer to the index (p. 495).

Dimensions (unit: mm)

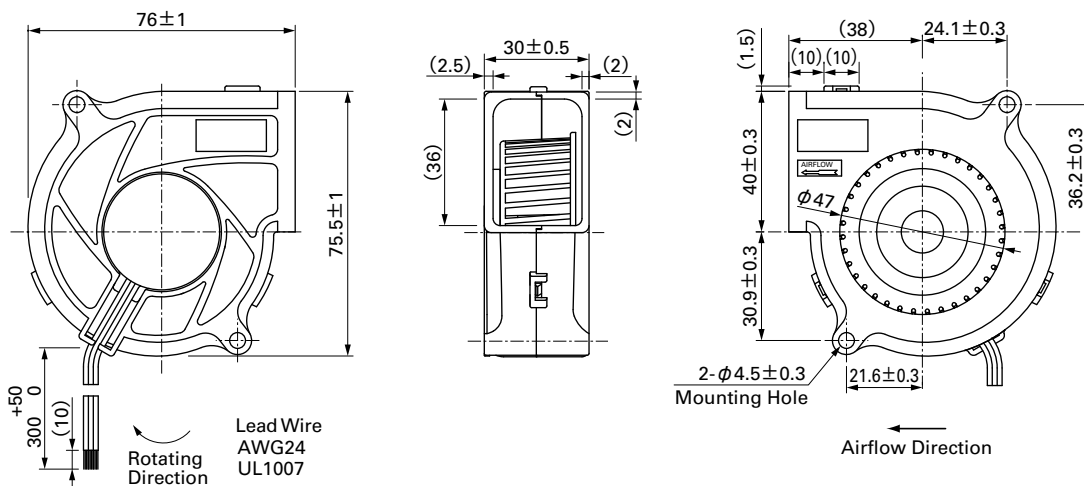

Airflow - Static Pressure Characteristics

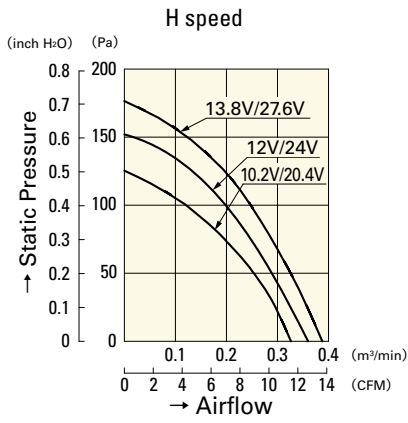

109BD12HC2
109BD24HC2

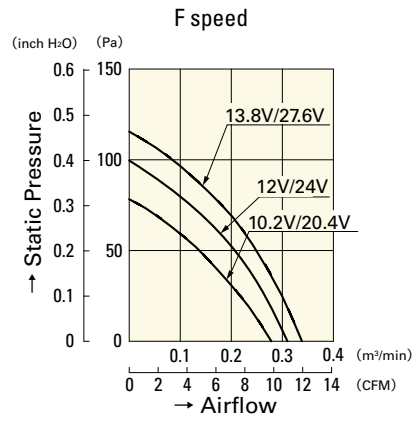

109BD12FC2
109BD24FC2

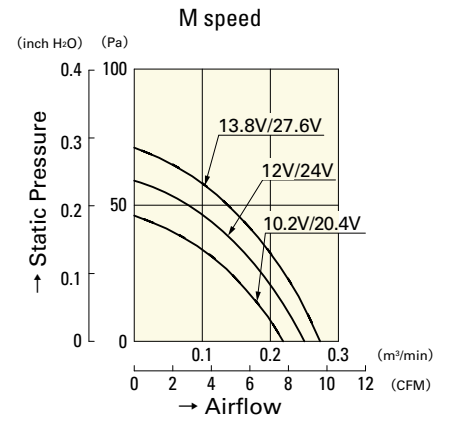

109BD12MC2
109BD24MC2

97 mm

San Ace B97



General Specifications

- Material..... Frame: Plastics (Flammability: UL94V-0),
Impeller: Plastics (Flammability: UL94V-0)
- Expected Life Refer to specifications (L10:Survival rate: 90% at 60°C ,
rated voltage, and continuously run in a free air state)
- Lead Wire ⊕red ⊖black (Sensor) yellow
- Storage Temperature -30°C to +70°C (Non-condensing)

97 mm × 33 mm (Mass : 175g) **9BM type**Specifications The following nos. **have pulse sensors.**

Model No.	Rated Voltage [V]	Operating Voltage Range [V]	Rated Current [A]	Rated Input [W]	Rated Speed [min ⁻¹]	Max. Airflow [m ³ /min] [CFM]	Max. Static Pressure [Pa] [inchH ₂ O]	SPL [dB(A)]	Operating Temperature [°C]	Expected Life [h]
109BM12GC2-1	12	7 to 13.8	0.60	7.20	3,800	0.82 28.9	281 1.129	51.5	-20 to +70	40,000/60°C (70,000/40°C)
109BM12HC2-1			0.40	4.80	3,300	0.71 25.1	204 0.819	48.5		
109BM12MC2-1			0.26	3.12	2,700	0.58 20.5	119 0.478	43.5		
109BM24GC2-1	24	12 to 27.6	0.31	7.44	3,800	0.82 28.9	281 1.129	51.5		
109BM24HC2-1			0.26	6.24	3,300	0.71 25.1	204 0.819	48.5		
109BM24MC2-1			0.15	3.60	2,700	0.58 20.5	119 0.478	43.5		

Other sensor specifications are available as options. Please refer to the index (p. 495).

Dimensions (unit: mm)

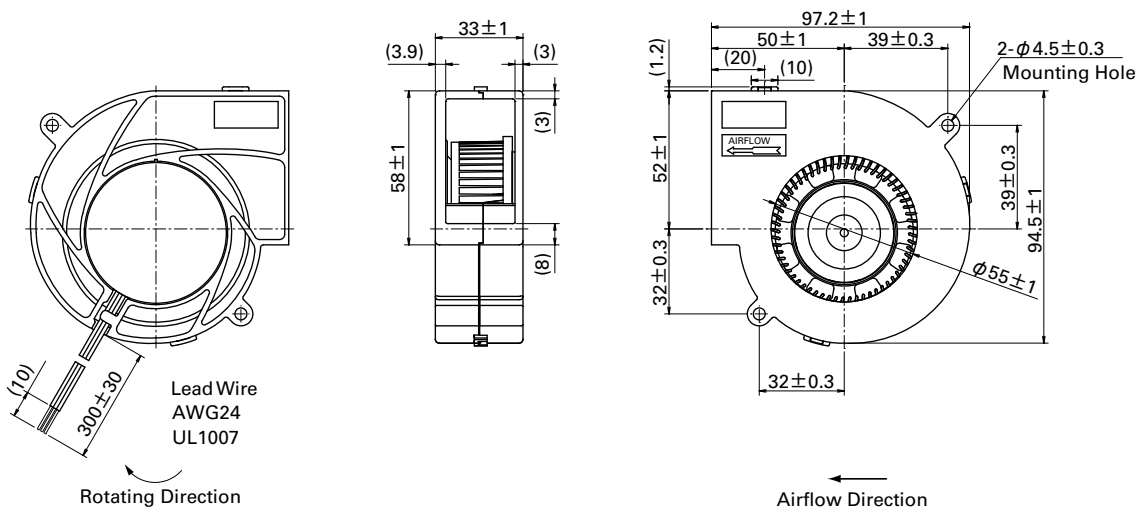

Airflow - Static Pressure Characteristics

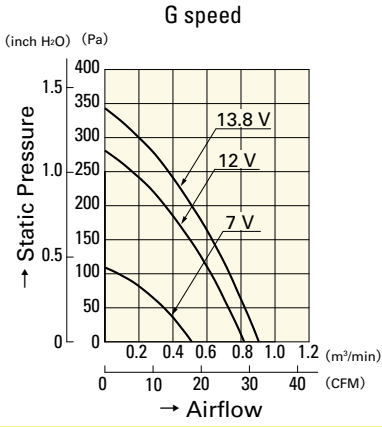

109BM12GC2-1

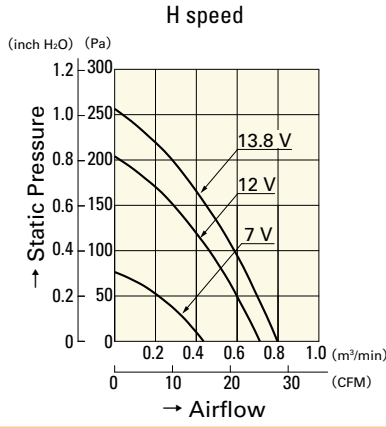

109BM12HC2-1

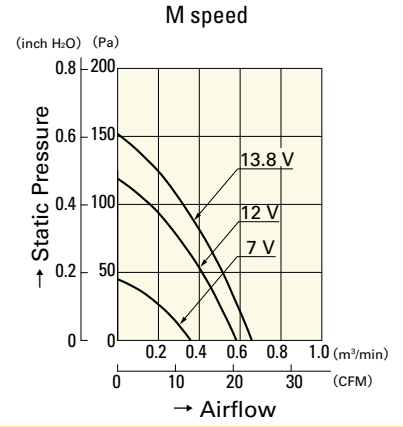

109BM12MC2-1

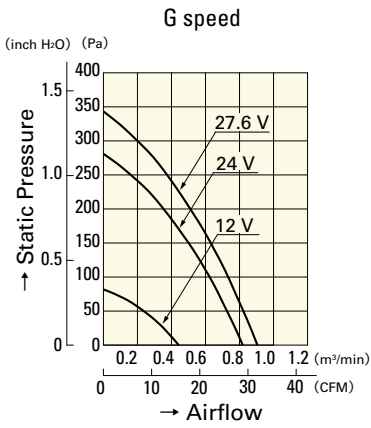

109BM24GC2-1

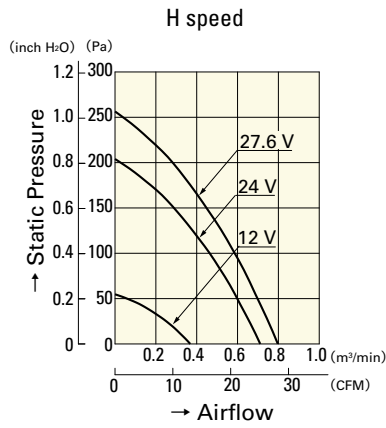

109BM24HC2-1

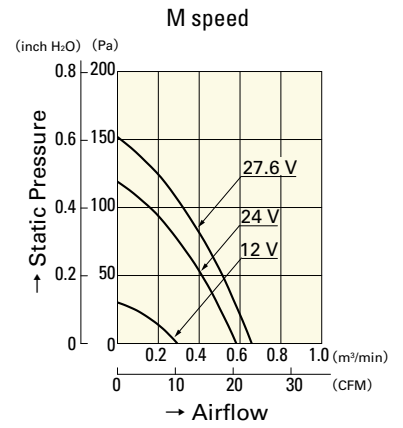

109BM24MC2-1

DC
Blower 97mm

97 mm

San Ace B97



General Specifications

- Material Frame: Plastics (Flammability: UL94V-0),
Impeller: Plastics (Flammability: UL94V-0)
- Expected Life Refer to specifications (L10:Survival rate: 90% at 60°C,
rated voltage, and continuously run in a free air state)
- Lead Wire ⊕red ⊖black (Sensor) yellow (Control) brown
(For models without PWM control function, there is no speed control wiring.)
- Storage Temperature ... -30°C to +70°C (Non-condensing)

97 mm × 33 mm (Mass : 190g) **9BMB type**

Specifications The following nos. have PWM controls and pulse sensors.

Model No.	Rated Voltage [V]	Operating Voltage Range [V]	PWM duty cycle ^{Note1)} [%]	Rated Current [A]	Rated Input [W]	Rated Speed [min ⁻¹]	Max. Airflow [m ³ /min] [CFM]	Max. Static Pressure [Pa] [inchH ₂ O]	SPL [dB(A)]	Operating Temperature [°C]	Expected Life [h]
9BMB12P2K01	12	10.8 to 13.2	100	3.4	40.8	6,850	1.61 56.8	1,280 5.14	66	-20 to +70	40,000/60°C
9BMB12P2G01			100	1.8	21.6	5,750	1.34 47.3	760 3.050	61		
9BMB12P2S01		10.2 to 13.8	100	1.4	16.8	5,250	1.22 43.1	610 2.450	59		
9BMB12P2H01			100	1.1	13.2	4,850	1.11 39.2	490 1.968	57		
9BMB12P2F01			100	0.9	10.8	4,500	1.04 36.7	410 1.64	56		
9BMB24P2K01	24	21.6 to 26.4	100	1.62	38.88	6,850	1.61 56.8	1,280 5.14	66		
9BMB24P2G01			100	0.83	19.92	5,750	1.34 47.3	760 3.05	61		
9BMB24P2S01			100	0.7	16.8	5,250	1.22 43.1	610 2.450	59		
9BMB24P2H01			100	0.55	13.2	4,850	1.11 39.2	490 1.968	57		
9BMB24P2F01			100	0.45	10.8	4,500	1.04 36.7	410 1.640	56		

Note: Fan does not rotate when PWM duty cycle is 0%.

※PWM Frequency : 25kHz

The following nos. have pulse sensors.

Model No.	Rated Voltage [V]	Operating Voltage Range [V]	Rated Current [A]	Rated Input [W]	Rated Speed [min ⁻¹]	Max. Airflow [m ³ /min] [CFM]	Max. Static Pressure [Pa] [inchH ₂ O]	SPL [dB(A)]	Operating Temperature [°C]	Expected Life [h]
9BMB12K201	12	7 to 13.2	3.4	40.8	6,850	1.61 56.8	1,280 5.14	66	-20 to +70	40,000/60°C
9BMB12G201			1.80	21.6	5,750	1.34 47.3	760 3.052	61		
9BMB12S201			1.40	16.8	5,250	1.22 43.1	610 2.450	59		
9BMB12H201			1.10	13.2	4,850	1.11 39.2	490 1.968	57		
9BMB12F201			0.90	10.8	4,500	1.04 36.7	410 1.647	56		
9BMB24K201	24	12 to 26.4	1.62	38.88	6,850	1.61 56.8	1,280 5.14	66		
9BMB24G201			0.83	19.9	5,750	1.34 47.3	760 3.052	61		
9BMB24S201			0.70	16.8	5,250	1.22 43.1	610 2.450	59		
9BMB24H201			0.55	13.2	4,850	1.11 39.2	490 1.968	57		
9BMB24F201			0.45	10.8	4,500	1.04 36.7	410 1.647	56		

Other sensor specifications are available as options. Please refer to the index (p. 501).

Dimensions (unit: mm) (With PWM control function · With pulse sensor)

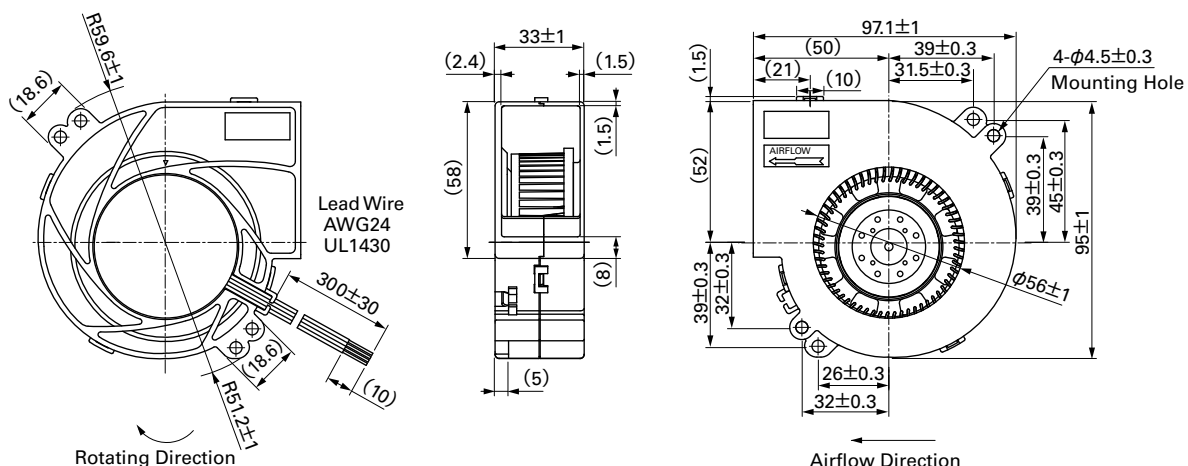

Airflow - Static Pressure Characteristics

PWM Duty - Speed Characteristics Example

PWM Duty Cycle

Operating Voltage Range

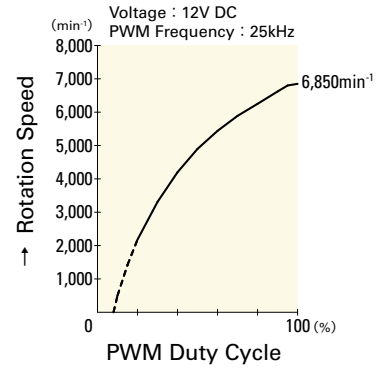
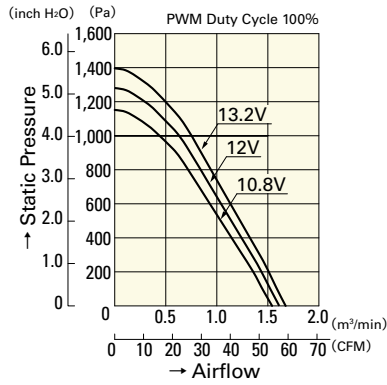
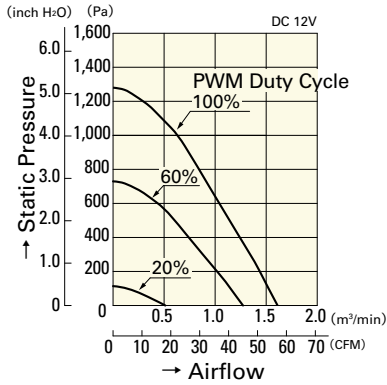

9BMB12P2K01

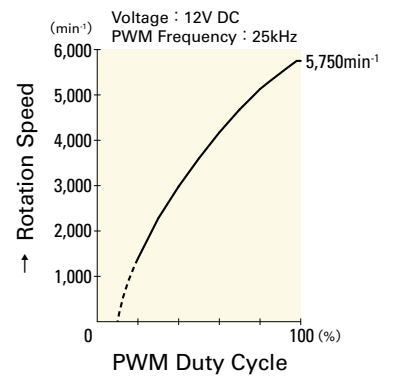
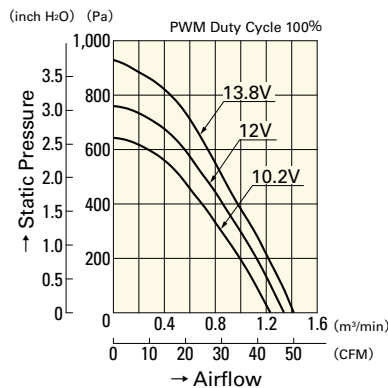
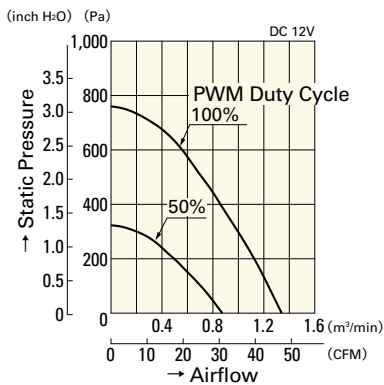

9BMB12P2G01

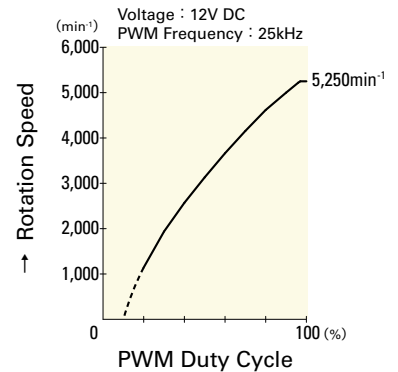
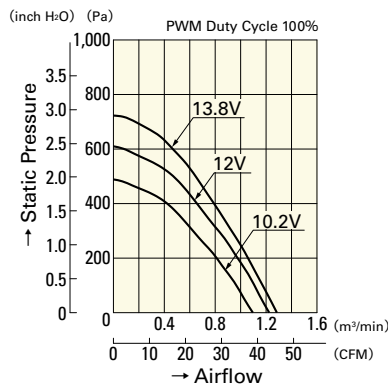
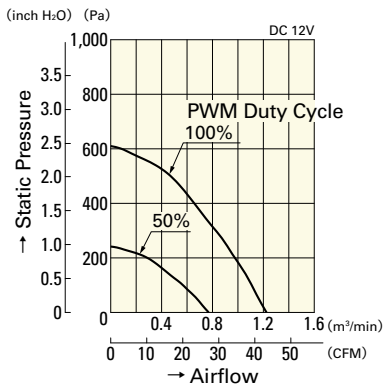

9BMB12P2S01

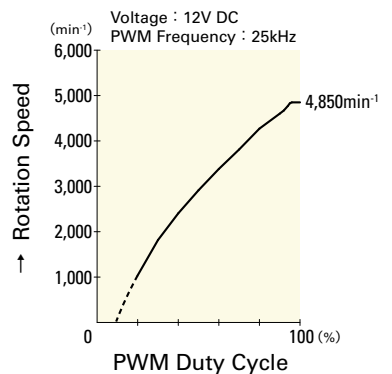
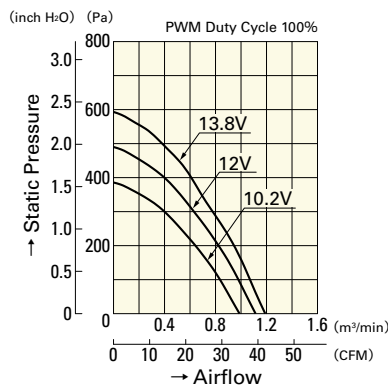
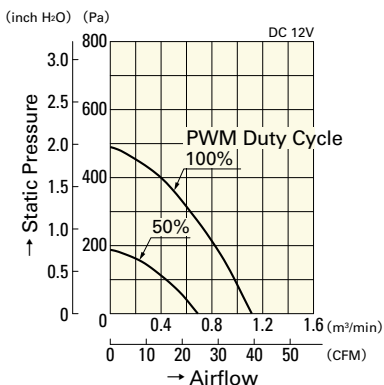

9BMB12P2H01

DC

Blower 97mm

97mm

San Ace B97

97mm × 33mm [Mass : 190g]

Airflow - Static Pressure Characteristics

PWM Duty - Speed Characteristics Example

PWM Duty Cycle

Operating Voltage Range

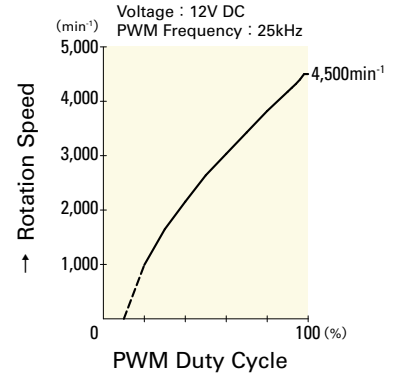
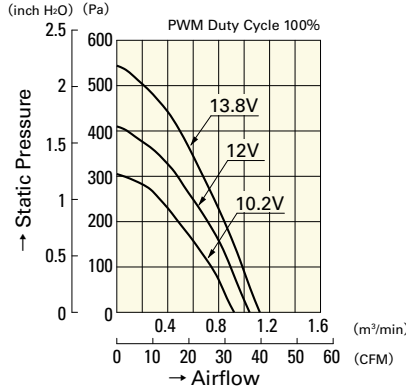
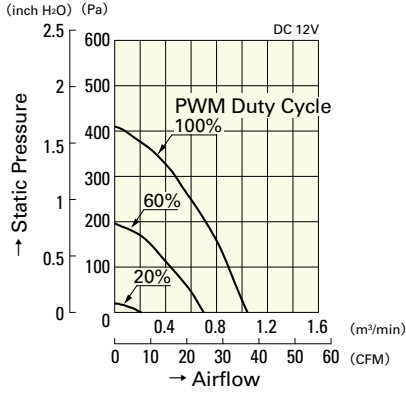

9BMB12P2F01

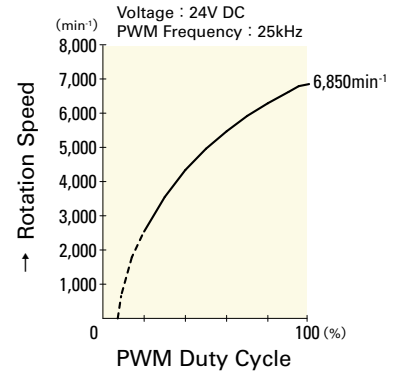
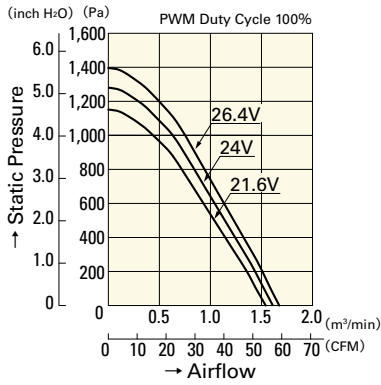
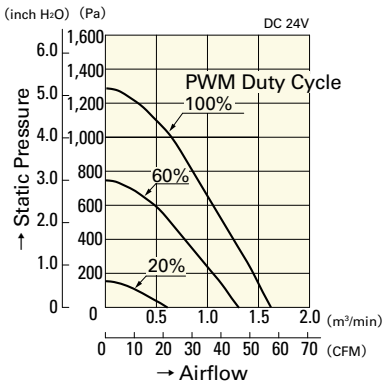

9BMB24P2K01

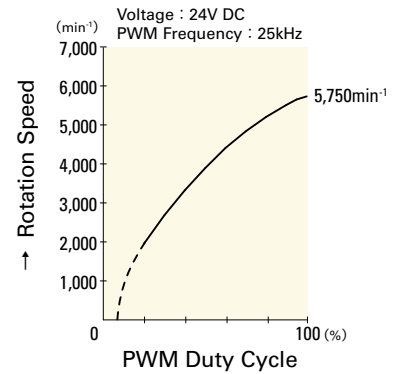
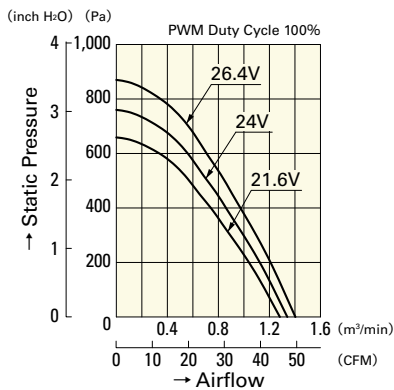
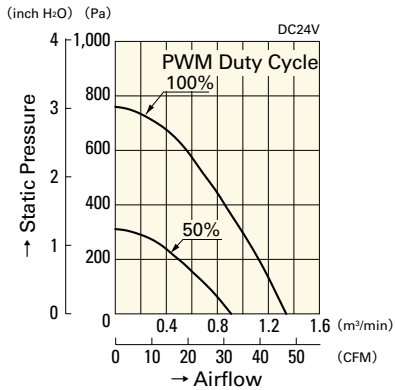

9BMB24P2G01

Airflow - Static Pressure Characteristics

PWM Duty Cycle

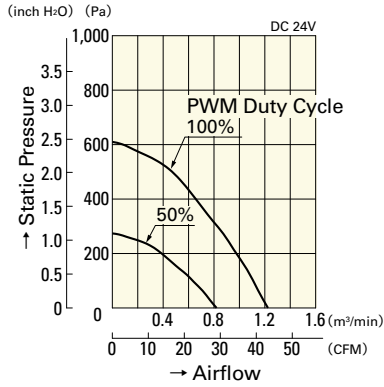

Operating Voltage Range

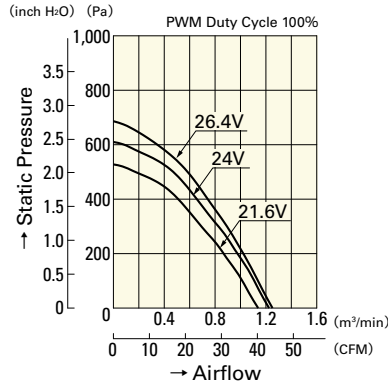

PWM Duty - Speed Characteristics Example

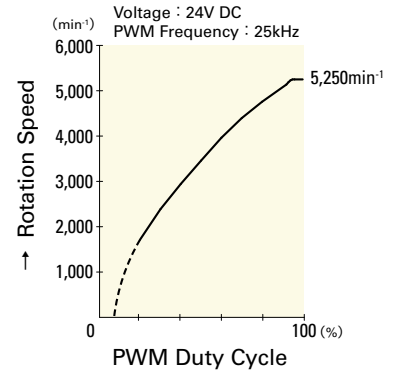

9BMB24P2S01

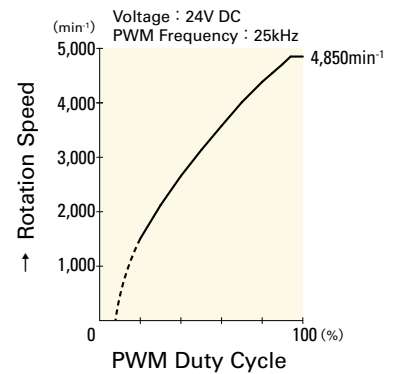
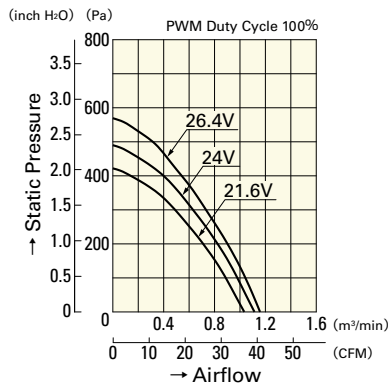
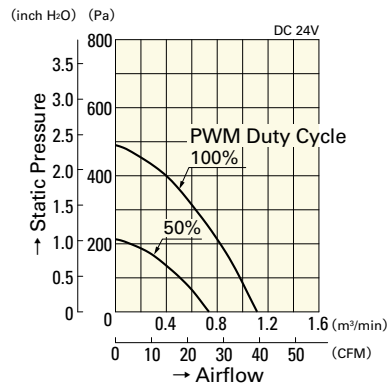

9BMB24P2H01

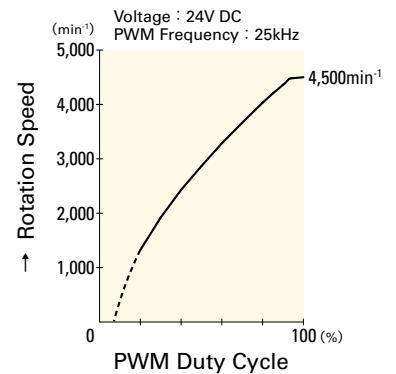
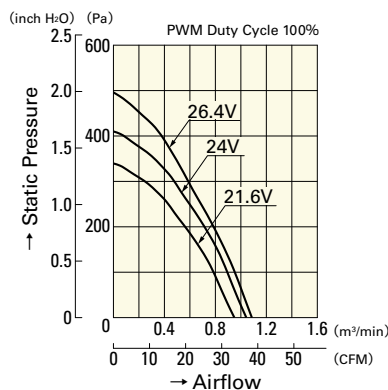
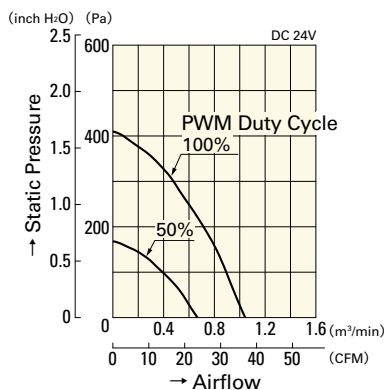

9BMB24P2F01

DC
Blower 97mm

97mm

San Ace B97

97mm × 33mm [Mass : 190g]

Airflow - Static Pressure Characteristics

Operating Voltage Range

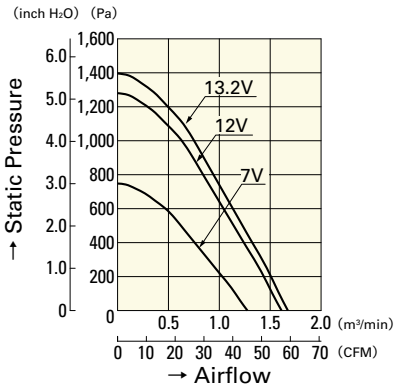

9BMB12K201

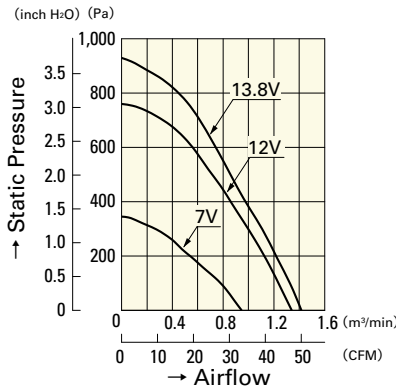

9BMB12G201

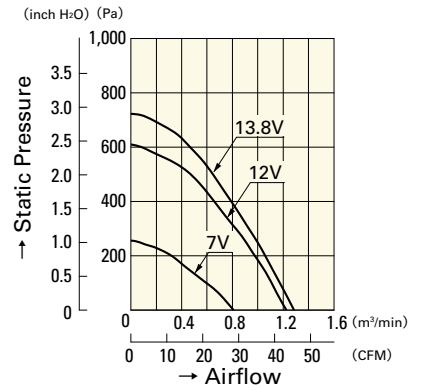

9BMB12S201

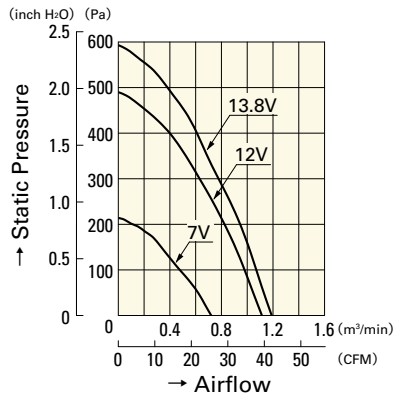

9BMB12H201

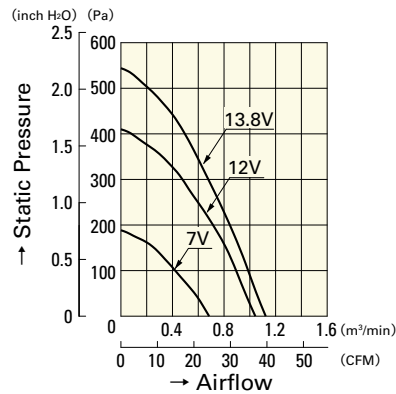

9BMB12F201

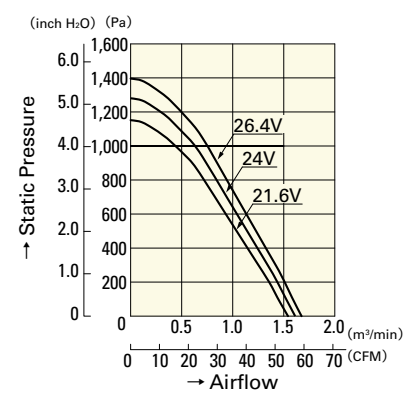

9BMB24K201

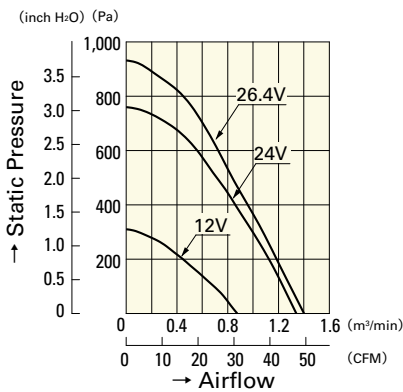

9BMB24G201

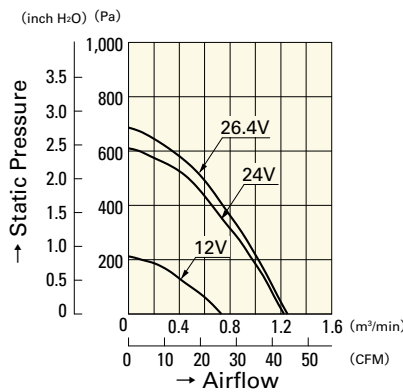

9BMB24S201

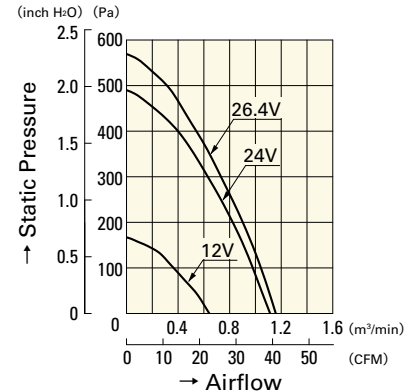

9BMB24H201

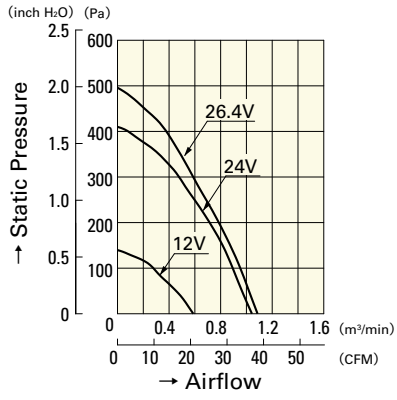

9BMB24F201

Blower 97mm DC

120mm**San Ace B120****General Specifications**

- Material Frame: Plastics (Flammability: UL94V-0),
Impeller: Plastics (Flammability: UL94V-0)
- Expected Life Refer to specifications (L10:Survival rate: 90% at 60°C ,
rated voltage, and continuously run in a free air state)
- Lead Wire ⊕red ⊖black (Sensor) yellow (Control) brown
- Storage Temperature -30°C to +70°C (Non-condensing)

120mm×32mm (Mass : 340g) **9BFB type** **Specifications** The following nos. **have PWM controls and pulse sensors.**

Model No.	Rated Voltage [V]	Operating Voltage Range [V]	PWM duty cycle* [%]	Rated Current [A]	Rated Input [W]	Rated Speed [min ⁻¹]	Max. Airflow [m ³ /min] [CFM]	Max. Static Pressure [Pa] [InchH ₂ O]	SPL [dB(A)]	Operating Temperature [°C]	Expected Life [h]
9BFB12P2H003 <small>(Note)</small>	12	10.8 to 13.2	100	2.3	27.6	3,750	1.6 56.5	1,250 5.02	62	-20 to +70	40,000/60°C (70,000/40°C)
9BFB24P2H003	24	21.6 to 26.4	100 0	1.1 0.12	26.4 2.88	3,750 1,300	1.6 56.5 0.46 16.2	1,250 5.02 43 0.17	62 41		

Note : Fan does not rotate when PWM duty cycle is 0%.

※PWM Frequency : 25kHz

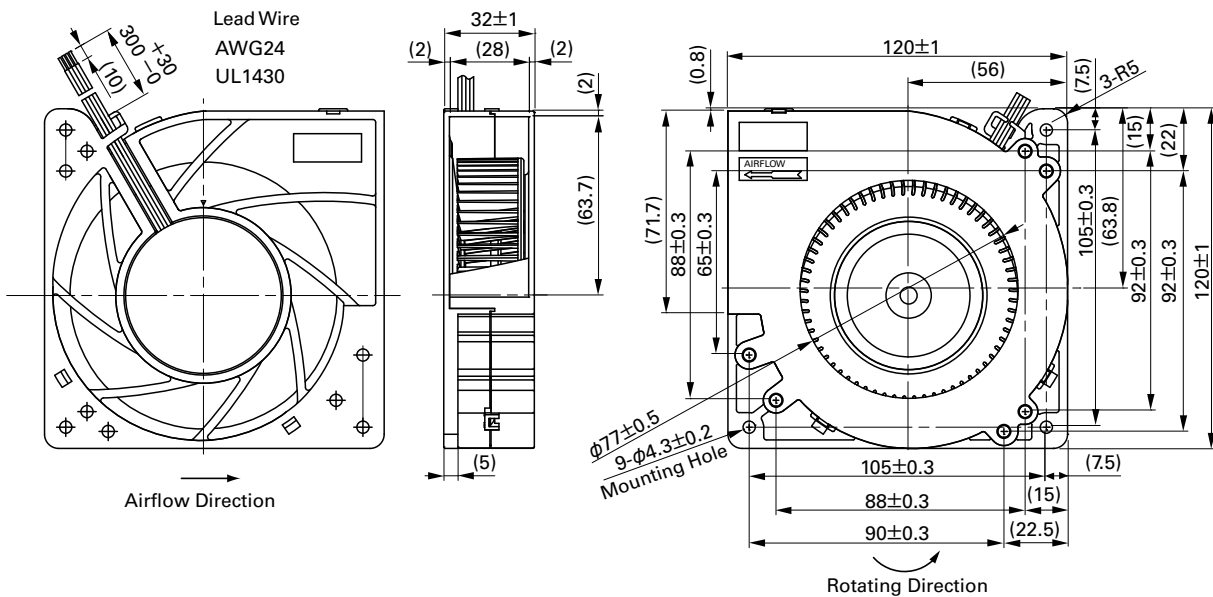
Dimensions (unit: mm)

Airflow - Static Pressure Characteristics

PWM Duty Cycle

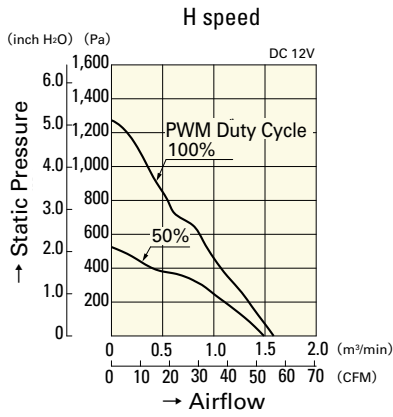

9BFB12P2H003

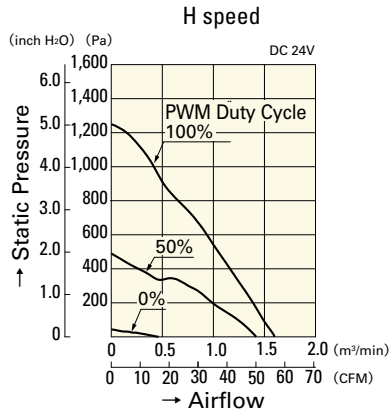

9BFB24P2H003

Operating Voltage Range

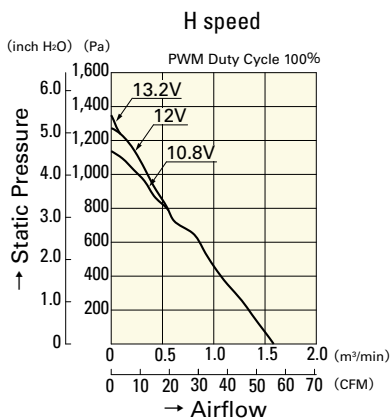

9BFB12P2H003

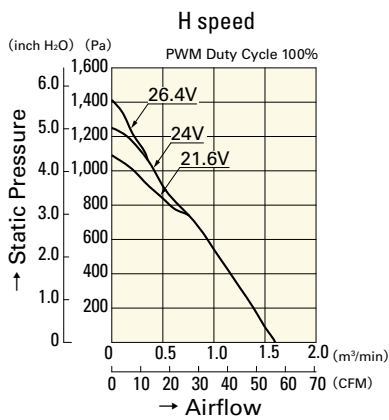

9BFB24P2H003

PWM Duty - Speed Characteristics Example

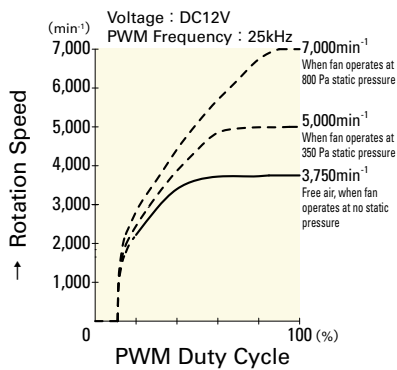

9BFB12P2H003

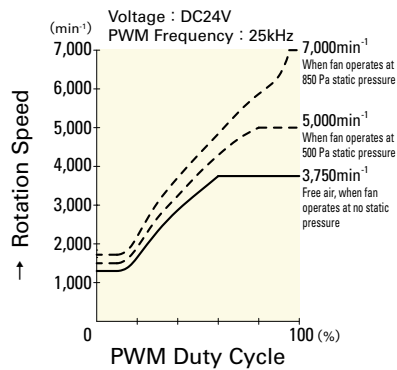

9BFB24P2H003

Blower 120mm DC

127mm**San Ace B127****General Specifications**

- Material..... Frame: Plastics (Flammability: UL94V-0),
Impeller: Plastics (Flammability: UL94V-1)
- Expected Life Refer to specifications (L10:Survival rate: 90% at 60°C ,
rated voltage, and continuously run in a free air state)
- Lead Wire ⊕red ⊖black or blue (Sensor) yellow
- Storage Temperature -30°C to +70°C (Non-condensing)

127mm×32mm (Mass : 290g) **9BJ type****Specifications** The following nos. **have pulse sensors.**

Model No.	Rated Voltage [V]	Operating Voltage Range [V]	Rated Current [A]	Rated Input [W]	Rated Speed [min ⁻¹]	Max. Airflow [m ³ /min] [CFM]	Max. Static Pressure [Pa] [inchH ₂ O]	SPL [dB(A)]	Operating Temperature [°C]	Expected Life [h]	
109BJ12HC2	12	10.2 to 13.8	0.52	6.24	2,400	0.78	27.5	205.8	0.826	46	40,000/60°C
109BJ12MC2			0.29	3.48	1,900	0.61	21.5	109.8	0.441	40	
109BJ24HC2	24	20.4 to 27.6	0.26	6.24	2,400	0.78	27.5	205.8	0.826	46	
109BJ24MC2			0.15	3.6	1,900	0.61	21.5	109.8	0.441	40	

Other sensor specifications are available as options. Please refer to the index (p. 495).

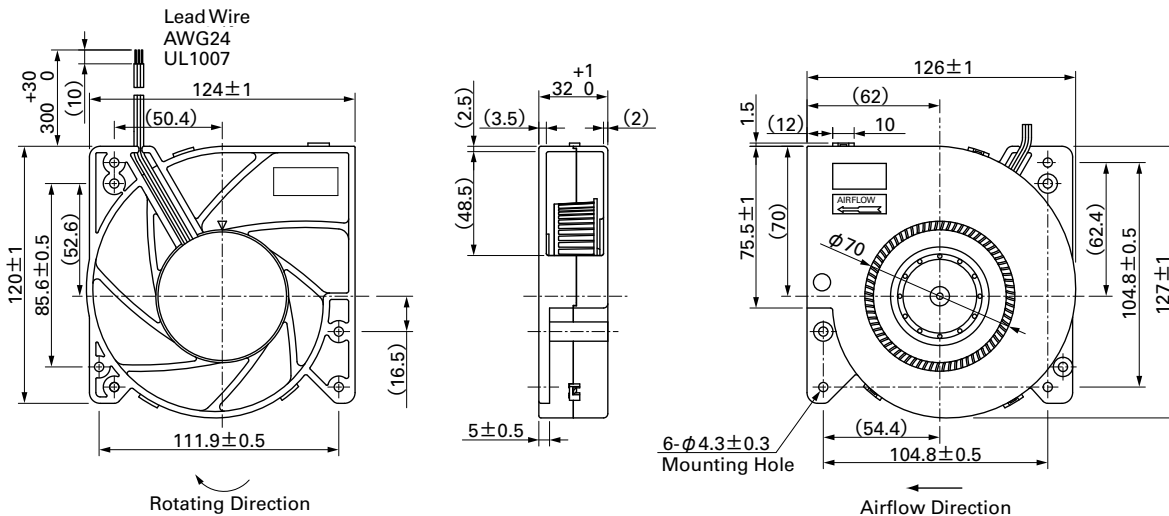
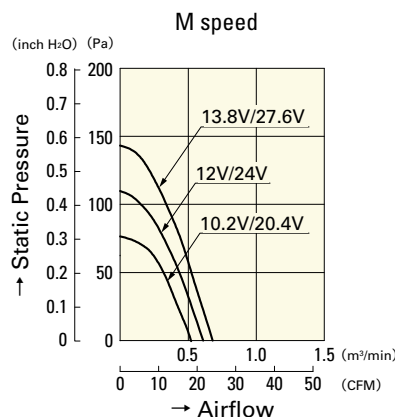
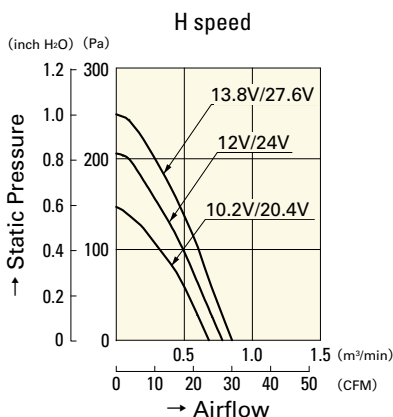
Dimensions (unit: mm)**Airflow - Static Pressure Characteristics**
109BJ12HC2
109BJ24HC2
109BJ12MC2
109BJ24MC2

160mm

San Ace B160



General Specifications

- Material Frame: Plastics (Flammability: UL94V-0),
Impeller: Plastics (Flammability: UL94V-1)
- Expected Life Refer to specifications (L10:Survival rate: 90% at 60°C ,
rated voltage, and continuously run in a free air state)
- Lead Wire ⊕red ⊖black or blue (Sensor) yellow
- Storage Temperature -30°C to +70°C (Non-condensing)

160mm×40mm (Mass : 580g) **9BG type**

Specifications

The following nos. **have pulse sensors**.

Model No.	Rated Voltage [V]	Operating Voltage Range [V]	Rated Current [A]	Rated Input [W]	Rated Speed [min ⁻¹]	Max. Airflow [m ³ /min] [CFM]	Max. Static Pressure [Pa] [inchH ₂ O]	SPL [dB(A)]	Operating Temperature [°C]	Expected Life [h]
109BG12HC1	12	10.2 to 13.8	1.3	15.6	2,300	1.62 57.2	313.6 1.259	55	- 20 to + 60	40,000/60°C
109BG12MC1			0.64	7.68	1,800	1.26 44.5	156.8 0.629	50		
109BG24HC1	24	20.4 to 27.6	0.62	14.88	2,300	1.62 57.2	313.6 1.259	55		
109BG24MC1			0.31	7.44	1,800	1.26 44.5	156.8 0.629	50		

Other sensor specifications are available as options. Please refer to the index (p. 495).

Dimensions (unit: mm)

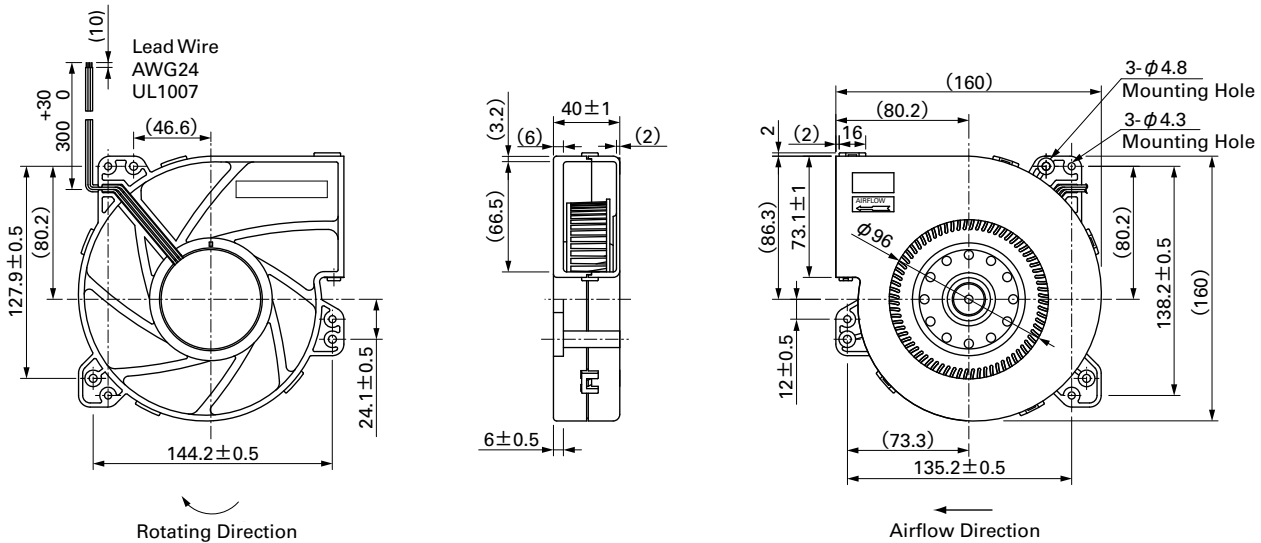

Airflow - Static Pressure Characteristics

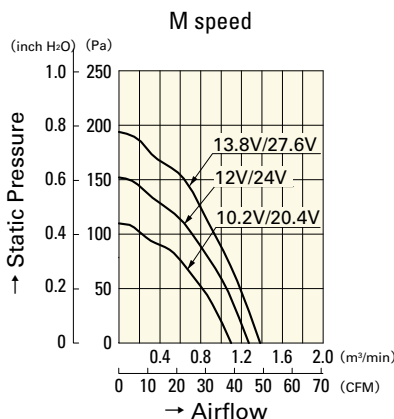
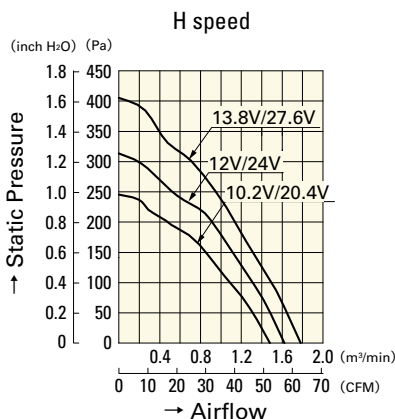

109BG12HC1
109BG24HC1

109BG12MC1
109BG24MC1

DC

Blower 127mm/160mm

ACDC Fan

This fan works while internally converting AC power into DC power, providing the superior performance of a DC fan with the flexibility of AC input.

Domain Diagram

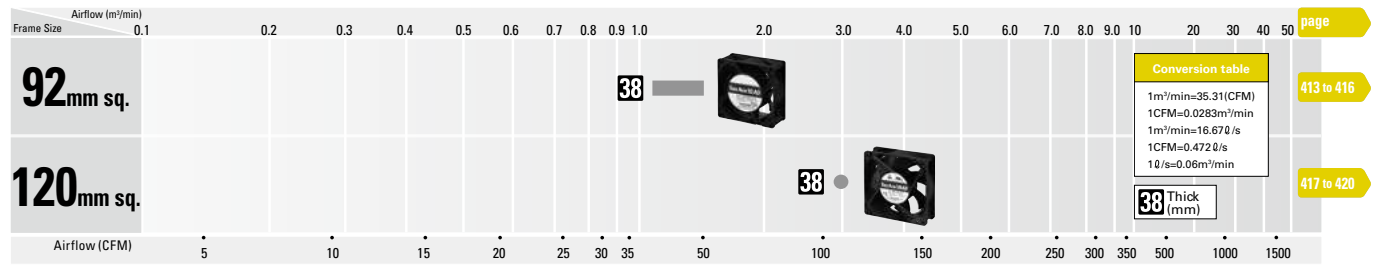

Model Numbering System

Not every combination of the following codes or characters is available. Contact us for an available combination.

9AD	09	01	H	1	2	
Type name / frame material 9AD / Plastics	Frame size 09: 92×92mm 12: 120×120mm	Voltage 100V to 240V	Speed code H, M	Frame thickness 1: 38mm thick	Sensor specifications 2: Without a sensor H: With a low-speed sensor	Frame form Nil: Plastics frame: Ribbed frame 1: Plastics frame: Ribless frame

How to Read Specifications

ACDC Fan											AC		
Model No.	① Rated Voltage [V]	② Operating Voltage Range [V]	③ Frequency [Hz]	④ Rated Current [A]	⑤ Rated Input [W]	⑥ Rated Speed [min ⁻¹]	⑦ Max. Airflow [m ³ /min] [CFM]		⑧ Max. Static Pressure [Pa] [inchH ₂ O]		⑨ SPL [dB(A)]	⑩ Operating Temperature [°C]	⑪ Expected Life [h]
9AD0901H12	100 to 240	90 to 264	50/60	0.08	4.5	3,850	1.50	53.0	90	0.36	40	-20 to +75	60,000/60°C
9AD0901M12				0.06	3.0	3,100	1.18	41.7	56	0.22	33		

- ① Rated Voltage This is the necessary voltage to drive the fan.
Single-phase 100 VAC to 240 VAC are also available.
- ② Operating Voltage Range ... The voltage range over which fan operation is guaranteed. 50/60Hz compatible.
- ③ Frequency This is a frequency of alternating current(AC). The frequencies of 50Hz and 60Hz are existing in Japan.
- ④ Rated Current The current value during the fan's rated operation without load.
- ⑤ Rated Input The input value during the fan's rated operation without load.
- ⑥ Rated Speed The rotating speed during the fan's rated operation without load.
- ⑦ Max. Airflow The maximum air volume that the fan can output during rated operation
(according to the company's dual-chamber device).
The volume of air generated by the fan in a given time period.
- ⑧ Max. Static Pressure The maximum static pressure value that the fan can output during rated operation
(according to the company's dual-chamber device).
The static pressure is the fan's force to propel air by overcoming the resistance of the device that uses the fan when it propels air.
- ⑨ SPL "SPL" is Sound Pressure Level. The noise level during the fan's rated operation.
Please refer to the technical material section for the method used to measure the noise level.
- ⑩ Operating Temperature The temperature range over which fan operation is guaranteed (Non- condensing)
- ⑪ Expected Life The fan's expected operating life when the fan operates continuously at the rated voltage at a temperature of 60° C and at relative humidity of 90%.
Please refer to the technical material section for the expected operating life.

ACDC Fan Common Specifications

- Material** Frame, Impeller: Plastics * For details, refer to the appropriate page.
- Expected Life** Varies for each model
(L10:Survival rate:90% at 60°C , rated voltage,and continuously run in a free air state)
- Motor Construction** Brushless DC motor
- Motor Protection System** .. Burnout protection at locked rotor condition
- Dielectric Strength** 50/60Hz 1500VAC 1minute
(between input terminal and frame, and between sensor output and frame)
- Insulation Resistance** 10M Ω or more at 500VDC megger (between lead conductor and frame)
- Sound Pressure Level(SPL)** .. Expressed as the value at 1m from air inlet side
- Operating Voltage Range** .. Varies depending on models.
- Lead Wire** For details, refer to the appropriate page.

Overheating protection function

Protection Functions
If the fan blades are restricted, an overcurrent occurs and leads to a rise in the fan coil temperature. This can result in reduced performance, damage, or a fire. To prevent this from occurring, SANYO DENKI's fans incorporate an overheating protection function.

Burnout protection function at locked rotor condition

- Current cutoff system (ACDC fan only)
If the fan blades are restricted, the coil current is cut off at regular cycles to prevent overheating of the coil. When the hindrance is removed, the fan restarts automatically.

92mm sq.

San Ace 92AD



General Specifications

- Material Frame: Plastics (Flammability: UL94V-0), Impeller: Plastics (Flammability: UL94V-0)
 - Expected Life Refer to specifications (L10:Survival rate: 90% at 60°C , rated voltage,and continuously run in a free air state)
 - Storage Temperature -30°C to +75°C (Non-condensing)
- * Do not weld directly onto AC input terminals.

92×92×38mm (Mass : 250g) **9AD type**

Specifications

The model no. below has **ribs and no sensors**. For models without ribs, append "1" to the model no.

Model No.	Rated Voltage [V]	Operating Voltage Range [V]	Frequency [Hz]	Rated Current [A]	Rated Input [W]	Rated Speed [min ⁻¹]	Max. Airflow [m ³ /min] [CFM]	Max. Static Pressure [Pa] [inchH ₂ O]	SPL [dB(A)]	Operating Temperature [°C]	Expected Life [h]
9AD0901H12	100 to 240	90 to 264	50/60	0.08	4.5	3,850	1.50 53.0	90 0.36	40	-20 to +75	60,000/60°C
9AD0901M12				0.06	3.0	3,100	1.18 41.7	56 0.22	33		

The model no. below has **ribs and low-speed sensors**. For models without ribs, append "1" to the model no.

Model No.	Rated Voltage [V]	Operating Voltage Range [V]	Frequency [Hz]	Rated Current [A]	Rated Input [W]	Rated Speed [min ⁻¹]	Max. Airflow [m ³ /min] [CFM]	Max. Static Pressure [Pa] [inchH ₂ O]	SPL [dB(A)]	Operating Temperature [°C]	Expected Life [h]
9AD0901H1H	100 to 240	90 to 264	50/60	0.08	4.5	3,850	1.50 53.0	90 0.36	40	-20 to +75	60,000/60°C
9AD0901M1H				0.06	3.0	3,100	1.18 41.7	56 0.22	33		

- Set Models** Fan, finger guard, plug cord, screws, etc. can be purchased in one package. For details, please refer to pp. 453 to 456.

Dimensions (unit: mm) (With ribs)

without Sensor

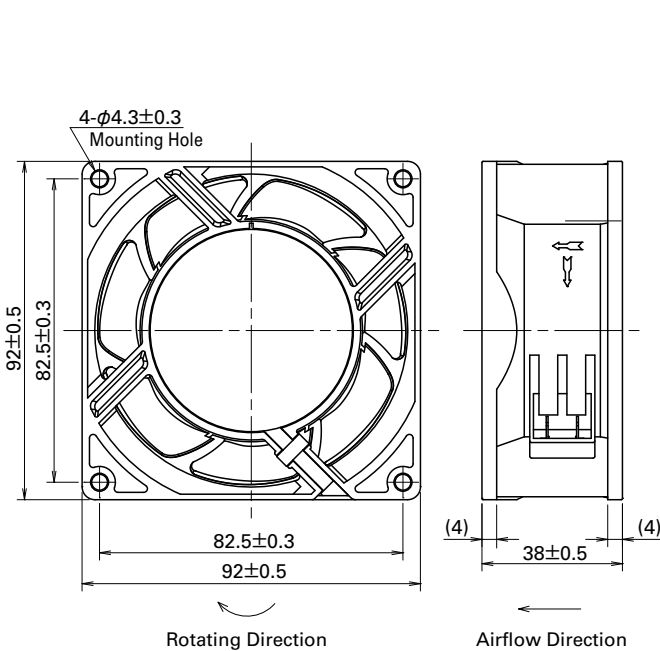

with Low-speed sensor

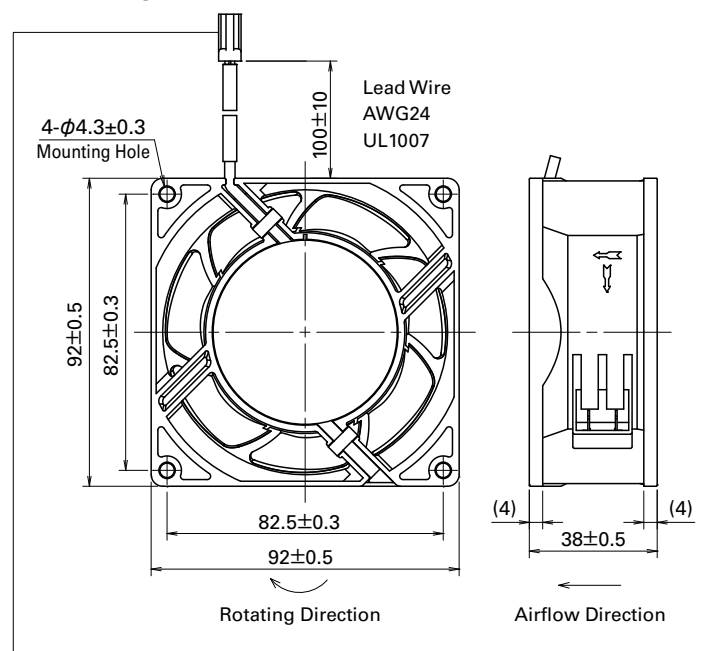

Connector: Tyco Electronics 171822-2
 (Pin1 Sensor output: Yellow Pin2 -: Black)
 Contact: Tyco Electronics 170262-1
 * Recommended connectors and contacts are listed below.
 Connector: Tyco Electronics 172211-2
 Contact: Tyco Electronics 170376-1

Reference Dimensions of Mounting Holes and Vent Opening (unit: mm)

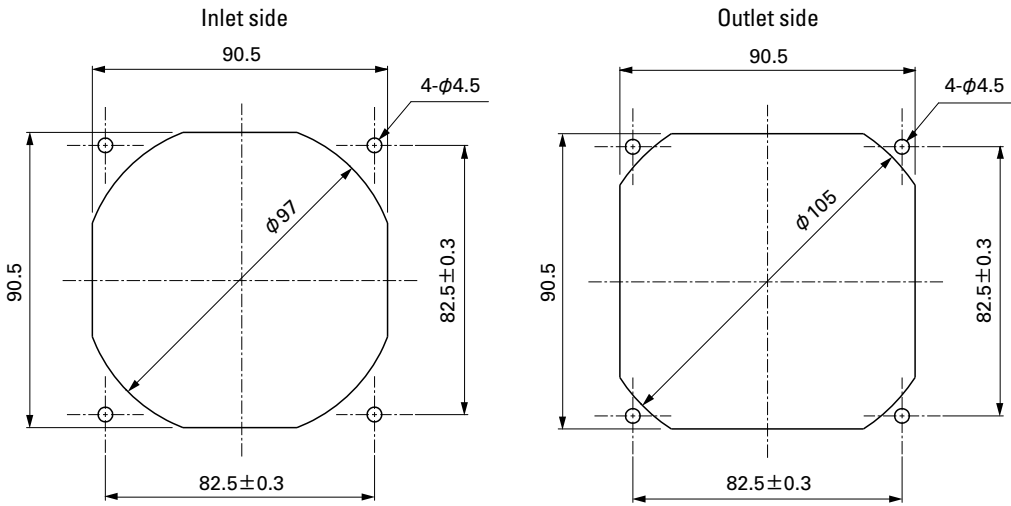

Options (unit: mm)

Finger Guards

Model : 109-099C Surface treatment : Nickel-chrome plating (silver) Color : Nickel-chrome plating (silver)

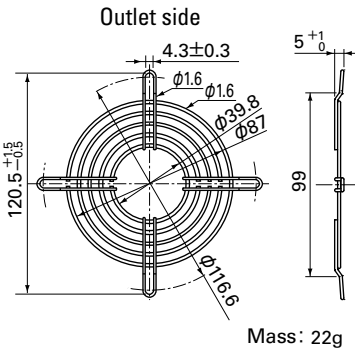

Resin Finger Guards

Model : 109-1001G

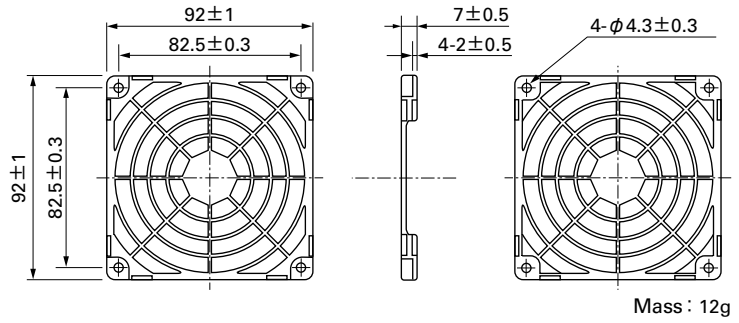

Model : 109-099E Surface treatment : Nickel-chrome plating (silver) Color : Nickel-chrome plating (silver)
: 109-099H : Cation electropainting (black)

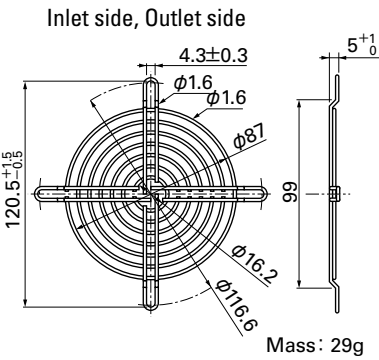

Resin Filter Kits

Model: 109-1001F13 (13PPI), 109-1001F20 (20PPI), 109-1001F30 (30PPI), 109-1001F40 (40PPI)

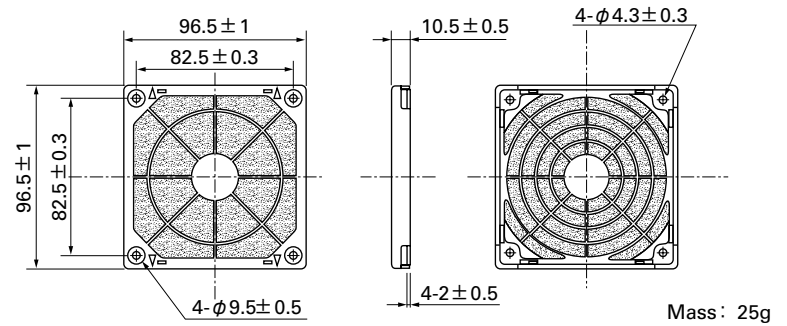

92mm sq.

San Ace 92AD

92×92×38mm [Mass : 250g]

Options (unit: mm)

Plug Cord

(Products compliant with Electrical Appliance and Material Safety Law, UL/CSA [c-UL] CERTIFIED)
 UL FILE No. E43202
 Model : 489-1635-L10/489-1635-L21

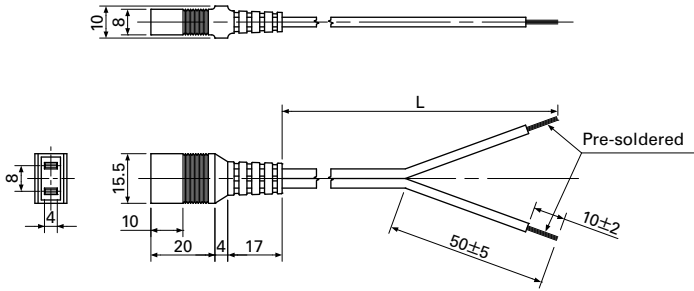

Model	Power cord length (L) [mm]	Mass [g]
489-1635-L10	1,000	38
489-1635-L21	2,100	74

Wiring Harness for Sensor

Model: 489-1636

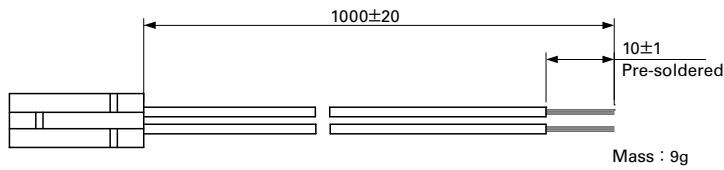

Airflow - Static Pressure Characteristics

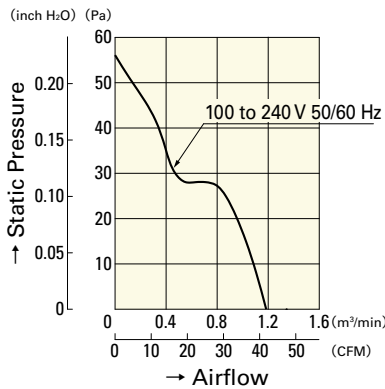
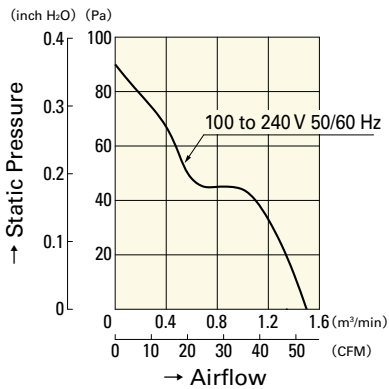

9AD0901H12
9AD0901H1H

9AD0901M12
9AD0901M1H

Wiring Diagram

Standard

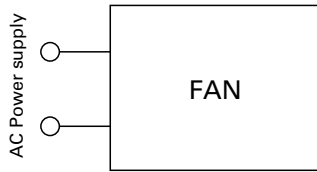

with Sensor

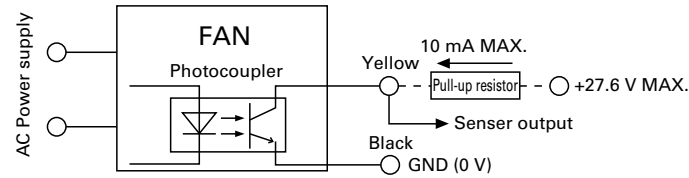

Specifications for Low-speed Sensors

Typical standard model: 9AD0901H1H

Output circuit: Open collector

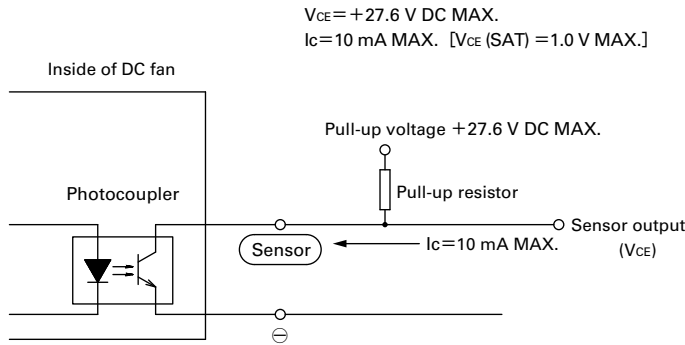

Sensor scheme

Example 1: when steady running

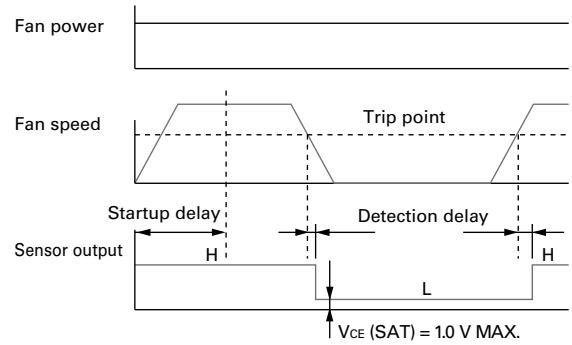

Example 2: when the rotor is locked when the fan motor is turned on and released after the start-up delay time.

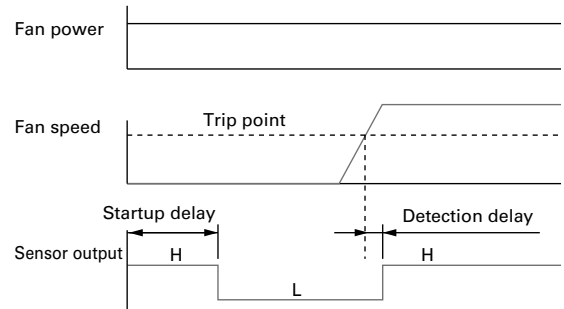

9AD0901H1H

Startup delay: $18 \pm 3 \text{ s}$

Detection delay: 3 s MAX.

Trip point: $1,700 \text{ min}^{-1}$

9AD0901M1H

Startup delay: $36 \pm 3 \text{ s}$

Detection delay: 3 s MAX.

Trip point: 850 min^{-1}

120mm sq.

San Ace 120AD



General Specifications

- Material Frame: Plastics (Flammability: UL94V-0), Impeller: Plastics (Flammability: UL94V-1)
 - Expected Life Refer to specifications (L10:Survival rate: 90% at 60°C , rated voltage,and continuously run in a free air state)
 - Storage Temperature -30°C to +75°C (Non-condensing)
- * Do not weld directly onto AC input terminals.

120×120×38mm [Mass : 290g] **9AD type**

Specifications

The model no. below has **ribs and no sensors**. For models without ribs, append "1" to the model no.

Model No.	Rated Voltage [V]	Operating Voltage Range [V]	Frequency [Hz]	Rated Current [A]	Rated Input [W]	Rated Speed [min ⁻¹]	Max. Airflow [m ³ /min] [CFM]	Max. Static Pressure [Pa] [inchH ₂ O]	SPL [dB(A)]	Operating Temperature [°C]	Expected Life [h]
9AD1201H12	100 to 240	90 to 264	50/60	0.08	4.4	3,250	3.0 106	84 0.34	42	-20 to +75	60,000/60°C

The model no. below has **ribs and low-speed sensors**. For models without ribs, append "1" to the model no.

Model No.	Rated Voltage [V]	Operating Voltage Range [V]	Frequency [Hz]	Rated Current [A]	Rated Input [W]	Rated Speed [min ⁻¹]	Max. Airflow [m ³ /min] [CFM]	Max. Static Pressure [Pa] [inchH ₂ O]	SPL [dB(A)]	Operating Temperature [°C]	Expected Life [h]
9AD1201H1H	100 to 240	90 to 264	50/60	0.08	4.4	3,250	3.0 106	84 0.34	42	-20 to +75	60,000/60°C

- Set Models** Fan, finger guard, plug cord, screws, etc. can be purchased in one package. For details, please refer to pp. 453 to 456.

Dimensions (unit: mm) (With ribs)

without Sensor

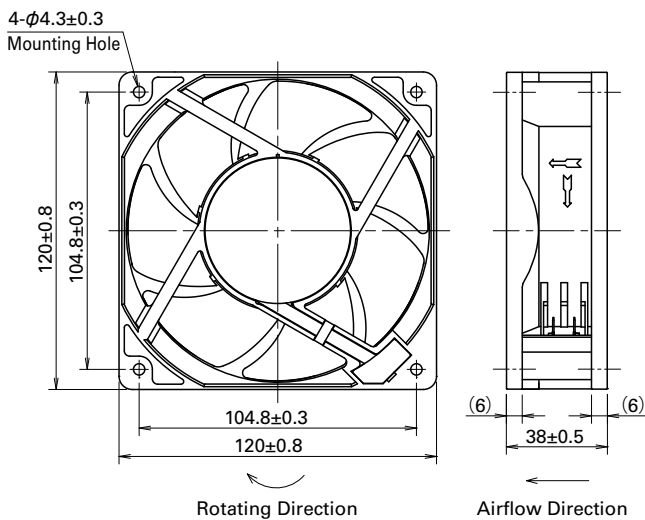

with Low-speed sensor

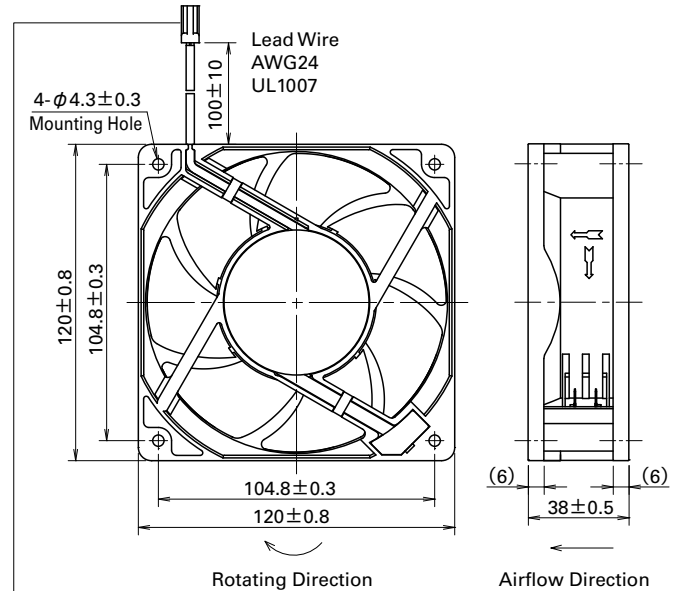

Connector: Tyco Electronics 171822-2
 (Pin1 Sensor output: Yellow Pin2 -: Black)
 Contact: Tyco Electronics 170262-1
 * Recommended connectors and contacts are listed below.
 Connector: Tyco Electronics 172211-2
 Contact: Tyco Electronics 170376-1

Reference Dimensions of Mounting Holes and Vent Opening (unit: mm)

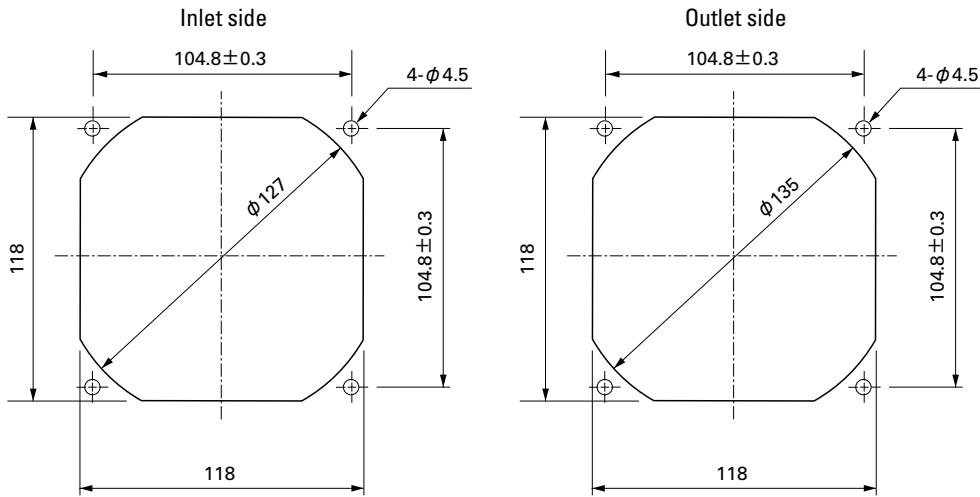

Options (unit: mm)

Finger Guards

Model : 109-019C Surface treatment : Nickel-chrome plating (silver) Color
 : 109-019H : Cation electropainting (black)

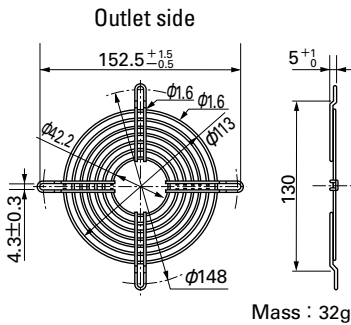

Resin Finger Guards

Model : 109-1000G

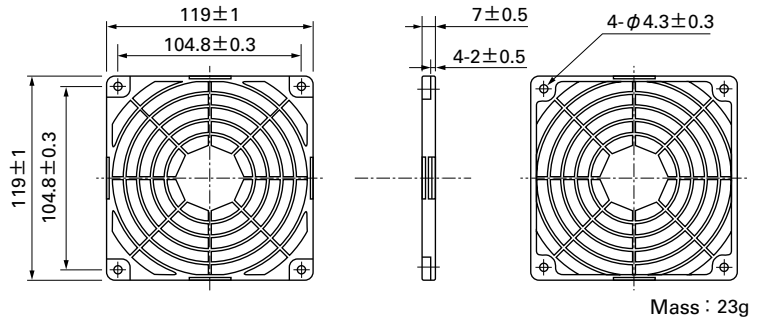

Model : 109-019E Surface treatment : Nickel-chrome plating (silver) Color
 : 109-019K : Cation electropainting (black)

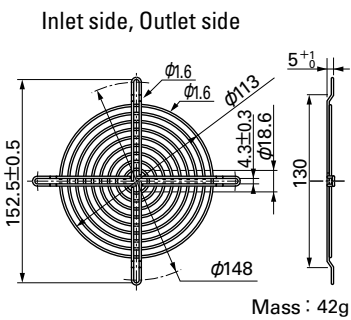

Resin Filter Kits

Model: 109-1000F13 (13PPI), 109-1000F20 (20PPI), 109-1000F30 (30PPI), 109-1000F40 (40PPI)

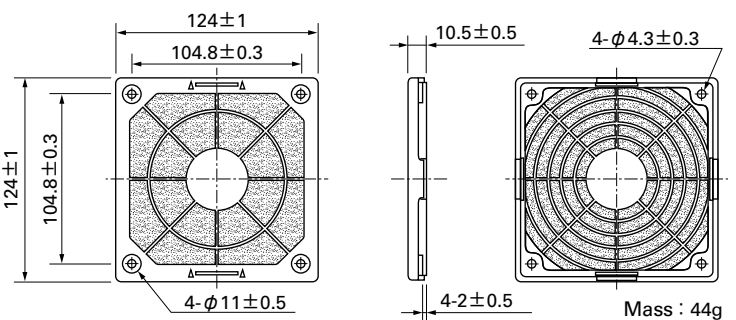

120 mm sq.

San Ace 120AD

120×120×38mm [Mass : 290g]

Options (unit: mm)

Plug Cord

(Products compliant with Electrical Appliance and Material Safety Law, UL/CSA [c-UL] CERTIFIED)
 UL FILE No. E43202
 Model : 489-1635-L10/489-1635-L21

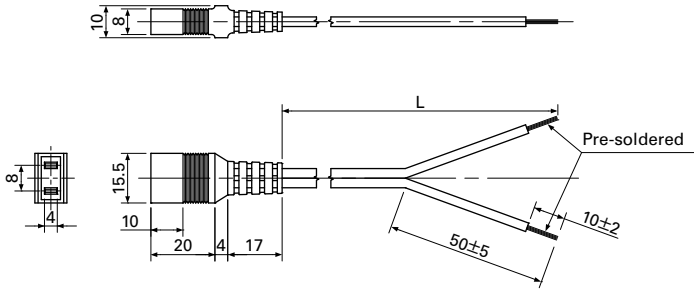

Model	Power cord length (L) [mm]	Mass [g]
489-1635-L10	1,000	38
489-1635-L21	2,100	74

Wiring Harness for Sensor

Model: 489-1636

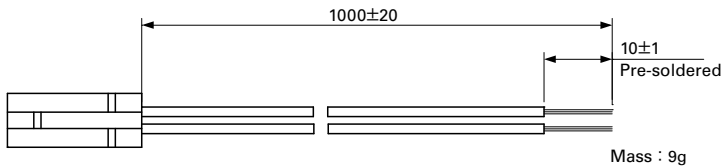

Airflow - Static Pressure Characteristics

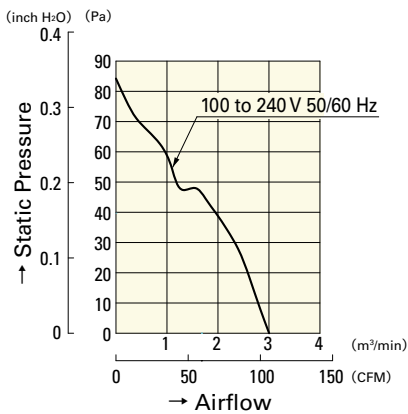

9AD1201H12

9AD1201H1H

Wiring Diagram

without Sensor

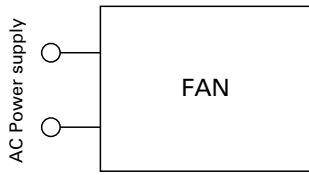

with Low-speed sensor

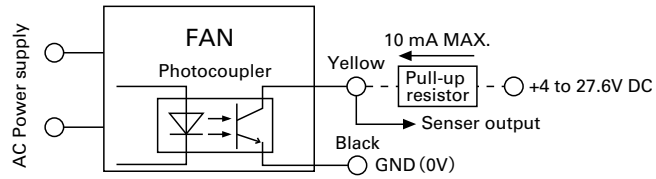

Specifications for Low-speed Sensors

Model No.: 9AD1201H1H

Output circuit: Open collector

$V_{CE} = +27.6 \text{ V DC MAX.}$
 $I_C = 10 \text{ mA MAX. [} V_{CE(SAT)} = 1.0 \text{ V MAX.]}$

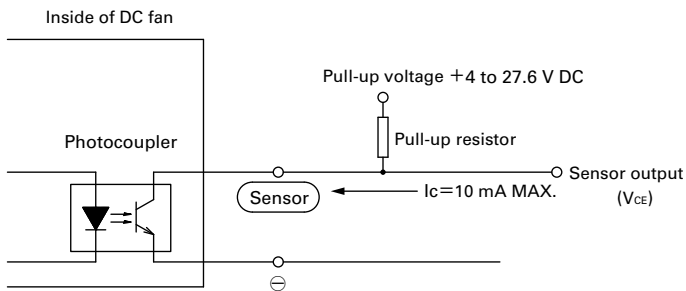

Sensor scheme

Example 1: when steady running

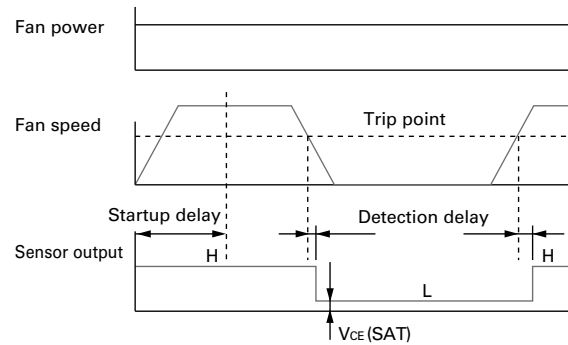

Example 2: when the rotor is locked when the fan motor is turned on and released after the start-up delay time.

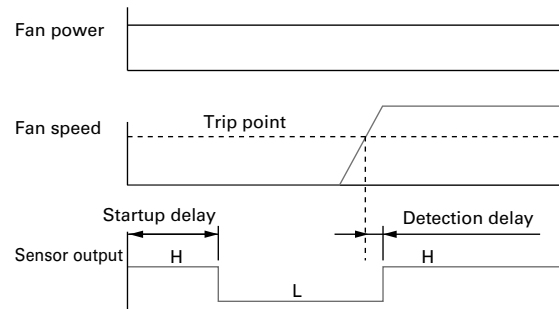

Startup delay: $18 \pm 3 \text{ s}$
 Detection delay: 3 s MAX.
 Trip point: $1,700 \text{ min}^{-1}$

AC Fan

The cooling fan operates at 100V to 230V AC.

Domain Diagram

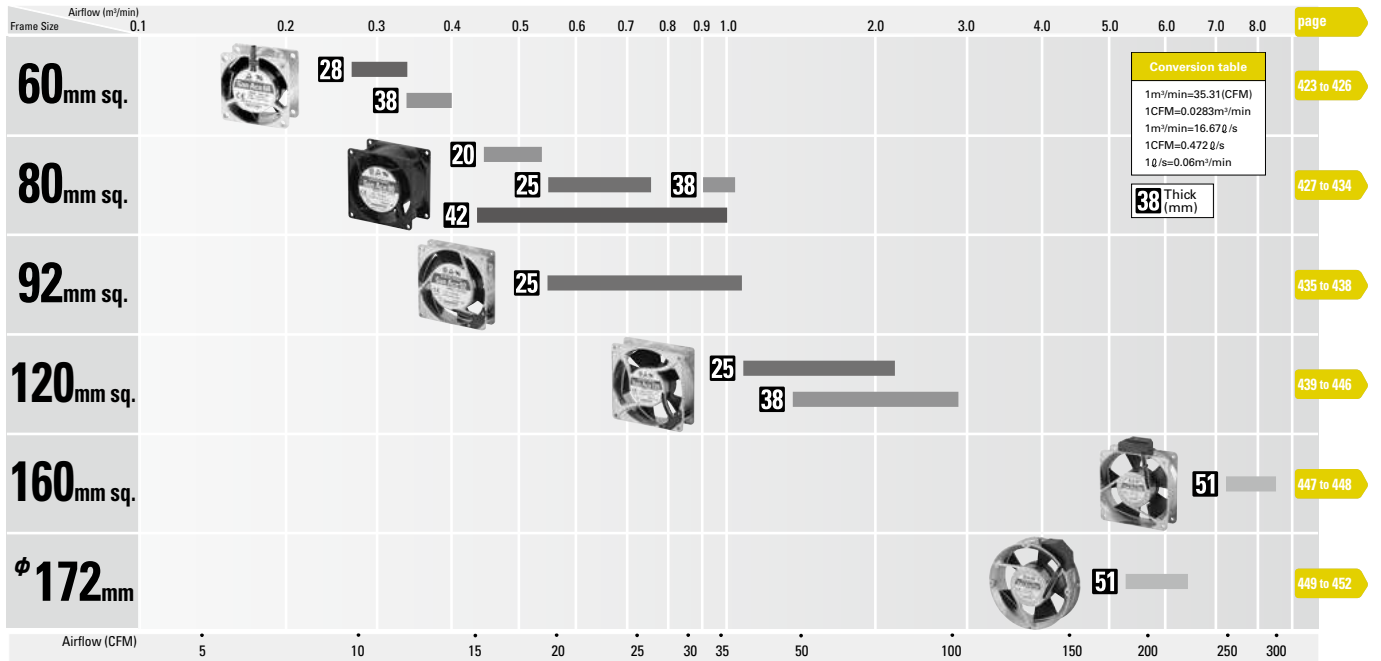

How to Read Specifications

AC Fan											AC		
Model No.	① Rated Voltage [V]	② Frequency [Hz]	③ Input [W]	④ Current [A]	⑤ Locked Rotor Current [A]	⑥ Rated Speed [min ⁻¹]	⑦ Max. Airflow [m ³ /min] [CFM]		⑧ Max. Static Pressure [Pa] [inchH ₂ O]		⑨ SPL [dB(A)]	⑩ Operating Temperature [°C]	⑪ Expected Life [h]
109-180	100	50/60	5/4	0.06/0.05	0.07/0.06	2,250/2,700	0.27/0.33	9.5/11.7	11.8/18.6	0.047/0.075	24/26	-30 to +70	25,000
109-183	115				0.06/0.05								

- ① Rated Voltage This is the necessary voltage to drive the fan.
Single-phase 100VAC, 115VAC, 200VAC and 230VAC are also available.
- ② Frequency This is a frequency of alternating current(AC). The frequencies of 50Hz and 60Hz are existing in Japan.
Performance of AC fan varies depending on the frequency.
Example: Rated speed 2,250/2,700 = 50Hz → 2,250, 60Hz → 2,700
- ③ Input The input value during the fan's rated operation without load.
- ④ Current The current value during the fan's rated operation without load.
- ⑤ Locked Rotor Current This is a current when rotor of motor that applies rated voltage is locked.
- ⑥ Rated Speed The rotating speed during the fan's rated operation without load.
- ⑦ Max. Airflow The maximum air volume that the fan can output during rated operation (according to the company's dual-chamber device).
The volume of air generated by the fan in a given time period.
- ⑧ Max. Static Pressure The maximum static pressure value that the fan can output during rated operation (according to the company's dual-chamber device).
The static pressure is the fan's force to propel air by overcoming the resistance of the device that uses the fan when it propels air.
- ⑨ SPL "SPL" is Sound Pressure Level. The noise level during the fan's rated operation.
Please refer to the technical material section for the method used to measure the noise level.
- ⑩ Operating Temperature The temperature range over which fan operation is guaranteed (Non- condensing)
- ⑪ Expected Life The fan's expected operating life when the fan operates continuously at the rated voltage at a temperature of 60°C and at relative humidity of 90%.
Please refer to the technical material section for the expected operating life.

AC Fan Common Specifications

- Material** Frame:Aluminum, Impeller:Plastics
- Expected Life** Varies for each model
(L10:Survival rate:90% at 60°C ,rated voltage,and continuously run in a free air state)
- Motor Construction** Shaded coil motor (60mm sq. 80mm sq. 92mm sq. 120mm sq.)
Capacitor motor (160mm sq. φ 172mm)
- Motor Protection System** Burnout protection at locked rotor condition
- Dielectric Strength** 50/60Hz 1500VAC 1minute
(between input terminal and frame or between lead conductor and frame *For details, refer to the appropriate page.)
- Insulation Resistance** 10M Ω or more at 500VDC megger
- Sound Pressure Level(SPL)** Expressed as the value at 1m from air inlet side
- Operating Voltage Range** Voltage of each model ± 10%
- Lead Wire** For details, refer to the appropriate page.

Overheating protection function AC

Protection Functions
If the fan blades are restricted, an overcurrent occurs and leads to a rise in the fan coil temperature. This can result in reduced performance, damage, or a fire. To prevent this from occurring, SANYO DENKI's fans incorporate an overheating protection function.

Burnout protection function at locked rotor condition

- Impedance protection (60mm sq. 80mm sq. 92mm sq. 120mm sq.)
This system is used for shading coil-type fans. When the blades are restricted, the current is reduced by the impedance of the coil itself to prevent a temperature rise in the coil. However, if the applied voltage exceeds the specification range, an overcurrent can occur and result in overheating, and so care needs to be taken.
- Thermal protection (160mm sq. φ 172mm)
This system is used for condenser phase-type fans. A temperature sensor is incorporated in the coil so that if the temperature exceeds the specification temperature, the current is cut off to prevent overheating of the coil.

60mm sq.

San Ace 60



General Specifications

- Material Frame: Aluminum,
Impeller: Plastics (Flammability: UL94V-1)
- Expected Life Refer to specifications (L10: Survival rate: 90% at 60°C ,
rated voltage, and continuously run in a free air state)
- Dielectric Strength 50/60Hz 1,500VAC 1minute (between lead conductor and frame)
- Lead Wire Black, 2pcs
- Storage Temperature -30°C to +70°C (Non-condensing)
- Operating Voltage Range Voltage of each model ± 10%

60×60×28mm (Mass : 120g)

Specifications

Model No.	Rated Voltage [V]	Frequency [Hz]	Input [W]	Current [A]	Locked Rotor Current [A]	Rated Speed [min ⁻¹]	Max. Airflow [m ³ /min] [CFM]	Max. Static Pressure [Pa] [inchHzO]	SPL [dB(A)]	Operating Temperature [°C]	Expected Life [h]
109-180	100	50/60	5/4	0.06/0.05	0.07/0.06	2,250/2,700	0.27/0.33 9.5/11.7	11.8/18.6 0.047/0.075	24/26	-30 to +70	25,000/60°C
109-183	115										

Set Models Fan, finger guard, plug cord, screws, etc. can be purchased in one package. For details, please refer to pp. 453 to 456.

Dimensions (unit: mm)

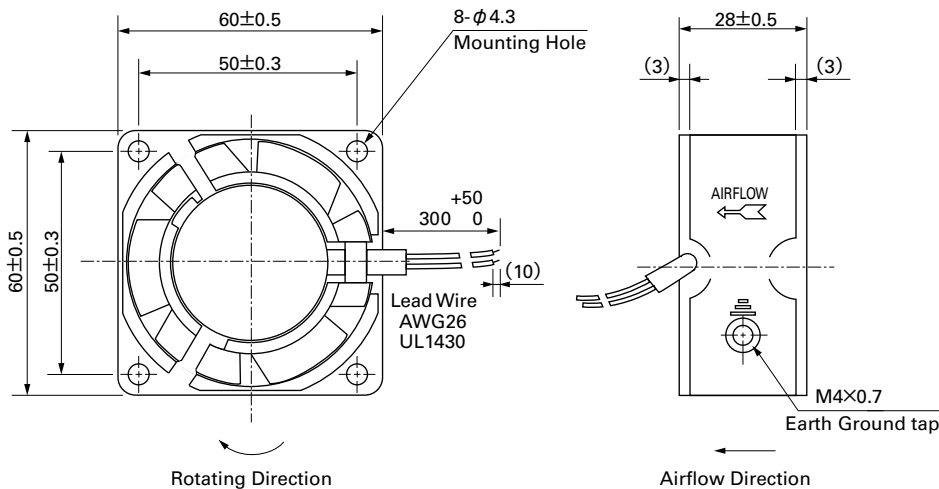

Reference Dimensions of Mounting Holes and Vent Opening (unit: mm)

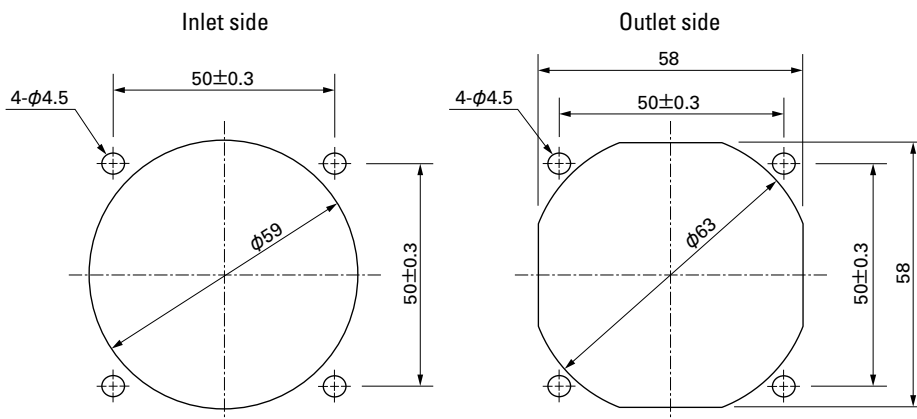

Wiring Diagram

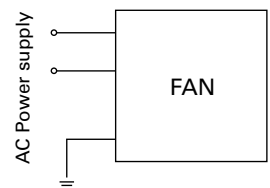

Options (unit: mm)

Finger Guards

Model : 109-139E Surface treatment : Nickel-chrome plating (silver) Color (silver)
 : 109-139H : Cation electropainting (black)

Inlet side, Outlet side

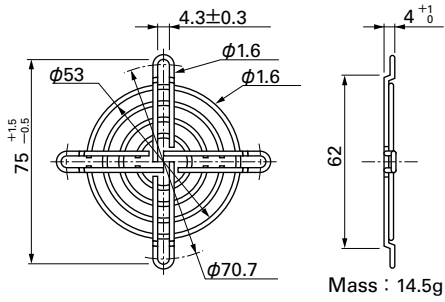

Resin Finger Guards

Model : 109-1003G

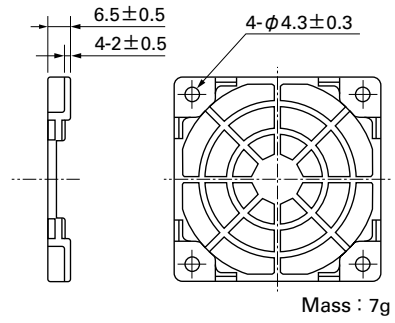
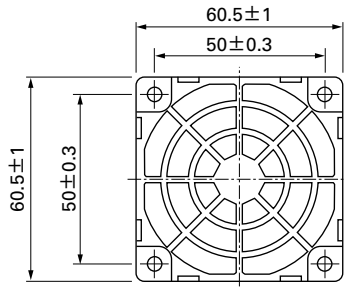

Resin Filter Kits

Model : 109-1003F13 (13PPI), 109-1003F20 (20PPI)
 : 109-1003F30 (30PPI), 109-1003F40 (40PPI)

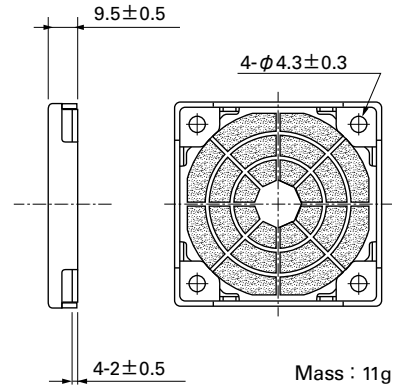
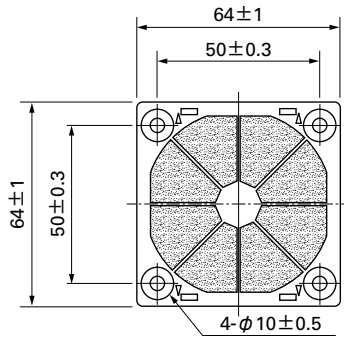

Airflow - Static Pressure Characteristics

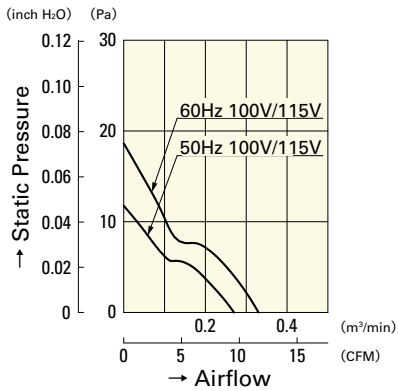

109-180

109-183

60mm sq.

San Ace 60



General Specifications

- Material..... Frame: Aluminum,
Impeller:Plastics (Flammability: UL94V-1)
- Expected Life Refer to specifications (L10: Survival rate: 90% at 60°C ,
rated voltage, and continuously run in a free air state)
- Dielectric Strength 50/60Hz 1,500VAC 1minute (between lead conductor and frame)
- Lead Wire Black, 2pcs
- Storage Temperature ... -30°C to +70°C (Non-condensing)
- Operating Voltage Range ... Voltage of each model ± 10%

60×60×38mm [Mass : 170g]

Specifications

Model No.	Rated Voltage [V]	Frequency [Hz]	Input [W]	Current [A]	Locked Rotor Current [A]	Rated Speed [min ⁻¹]	Max. Airflow [m ³ /min] [CFM]	Max. Static Pressure [Pa] [inchHzO]	SPL [dB(A)]	Operating Temperature [°C]	Expected Life [h]
109-130	100	50/60	6/5	0.08/0.07	0.08/0.07	2,600/3,150	0.33/0.4 11.7/14.1	16.3/23.3 0.065/0.094	28/30	-30 to +60	25,000/60°C
109-133	115			0.07/0.06	0.07/0.06						

Set Models Fan, finger guard, plug cord, screws, etc. can be purchased in one package. For details, please refer to pp. 453 to 456.

Dimensions (unit: mm)

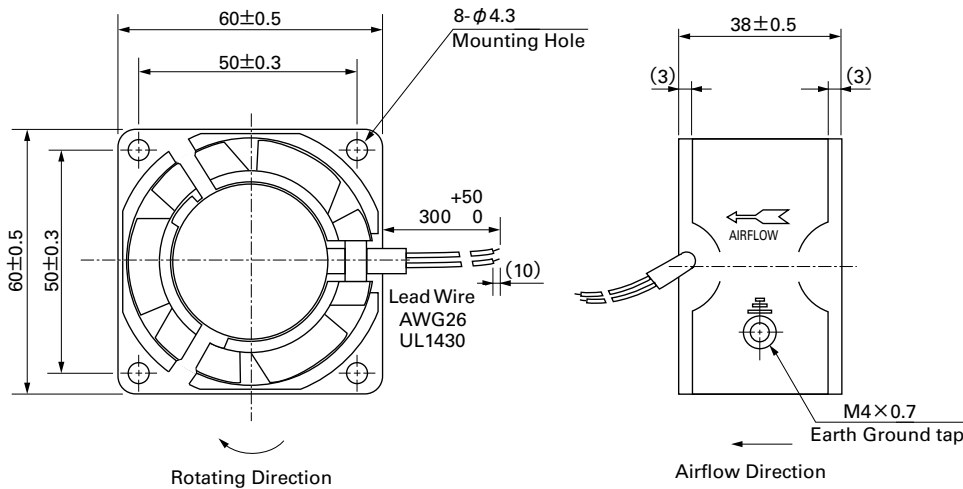

Reference Dimensions of Mounting Holes and Vent Opening (unit: mm)

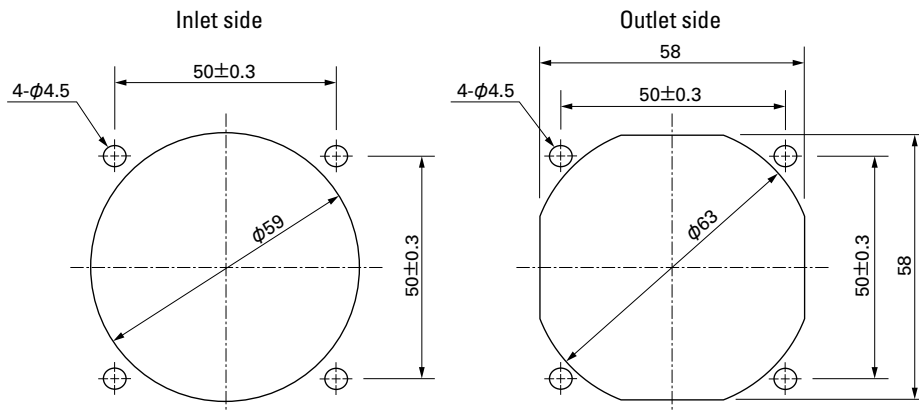

Wiring Diagram

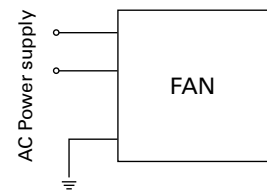

Options (unit: mm)

Finger Guards

Model : 109-139E Surface treatment : Nickel-chrome plating (silver) Color
 : 109-139H : Cation electropainting (black)

Inlet side, Outlet side

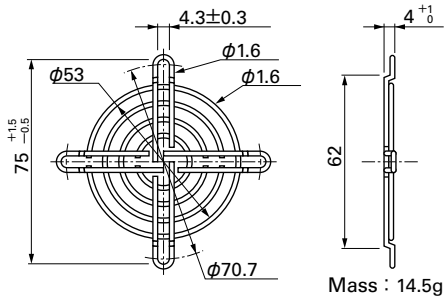

Resin Finger Guards

Model : 109-1003G

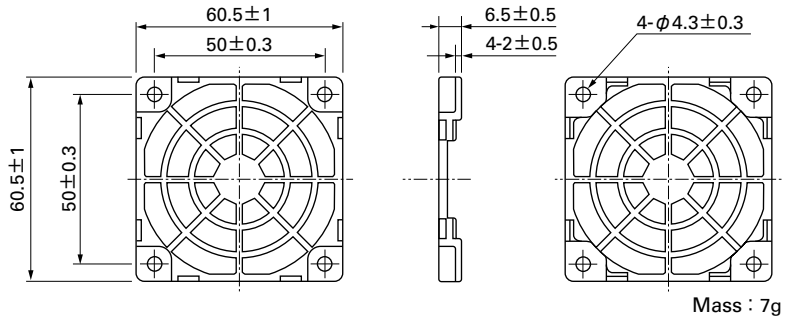

Resin Filter Kits

Model : 109-1003F13 (13PPI), 109-1003F20 (20PPI)
 : 109-1003F30 (30PPI), 109-1003F40 (40PPI)

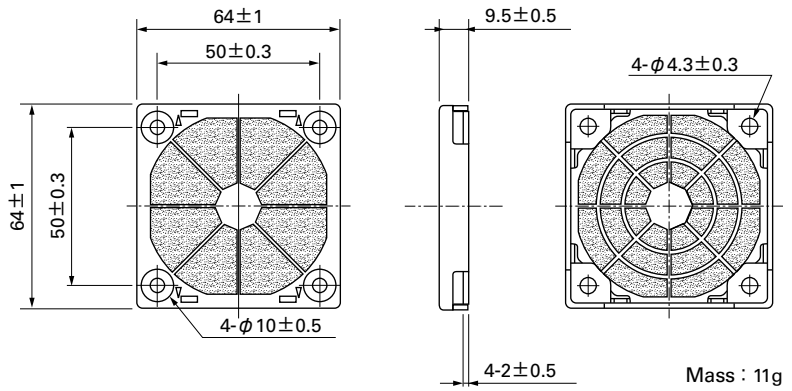

Airflow - Static Pressure Characteristics

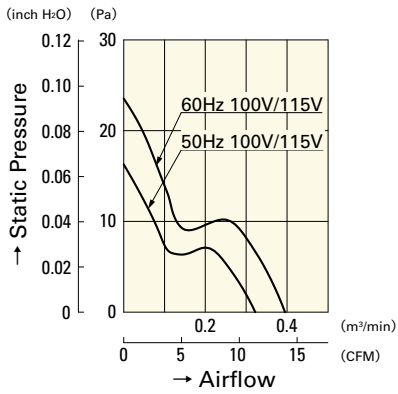

109-130

109-133

80 mm sq.

San Ace 80



General Specifications

- Material Frame: Aluminum,
Impeller:Plastics (Flammability: UL94V-1)
- Expected Life Refer to specifications (L10:Survival rate: 90% at 60°C ,
rated voltage,and continuously run in a free air state)
- Dielectric Strength 50/60Hz 1,500VAC 1minute (between lead conductor and frame)
- Lead Wire Black, 2pcs
- Storage Temperature -30°C to +70°C (Non-condensing)
- Operating Voltage Range Voltage of each model ± 10%

80×80×20mm (Mass : 180g)

Specifications

Model No.	Rated Voltage [V]	Frequency [Hz]	Input [W]	Current [A]	Locked Rotor Current [A]	Rated Speed [min ⁻¹]	Max. Airflow [m ³ /min] (CFM)	Max. Static Pressure [Pa] [inchHzO]	SPL [dB(A)]	Operating Temperature [°C]	Expected Life [h]
109-210	100	50/60	6/5	0.07/0.06	0.07/0.06	2,500/3,000	0.44/0.53 15.5/18.7	23.5/31.4 0.094/0.126	26/31	-30 to +60	25,000/60°C
109-213	115			0.06/0.05	0.06/0.05						

Set Models Fan, finger guard, plug cord, screws, etc. can be purchased in one package.
For details, please refer to pp. 453 to 456.

Dimensions (unit: mm)

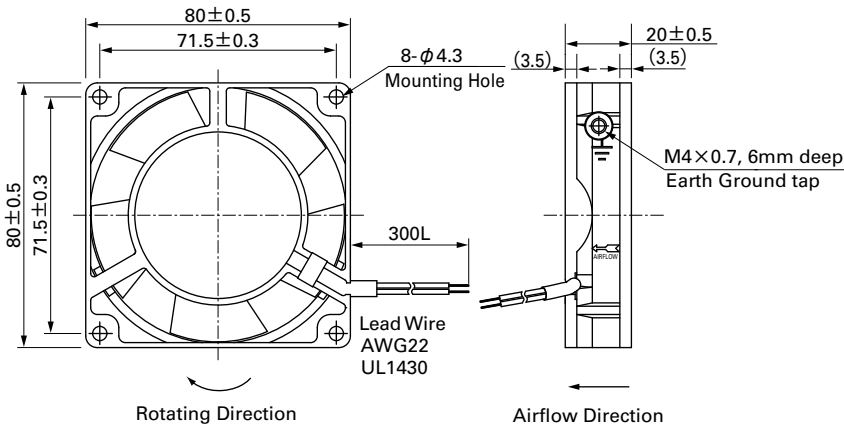

Reference Dimensions of Mounting Holes and Vent Opening (unit: mm)

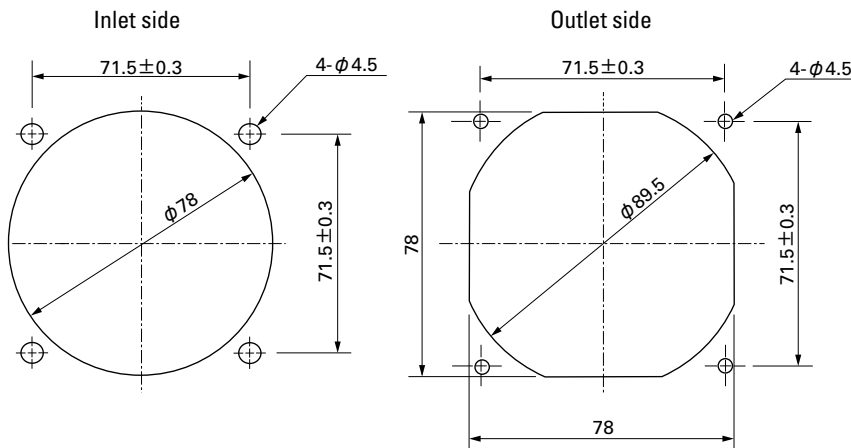

Wiring Diagram

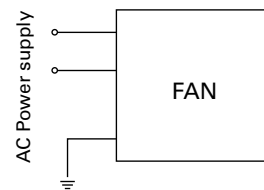

Options (unit: mm)

Finger Guards

Model : 109-049C Color : Nickel-chrome plating (silver)
 Surface treatment : Nickel-chrome plating (silver)
 : 109-049H Color : Cation electropainting (black)

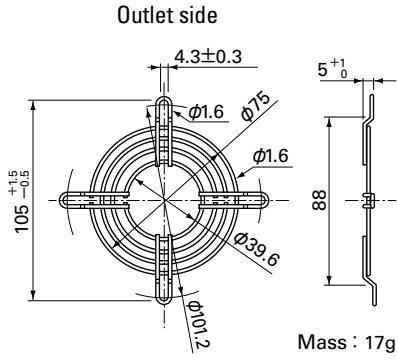

Resin Finger Guards

Model : 109-1002G

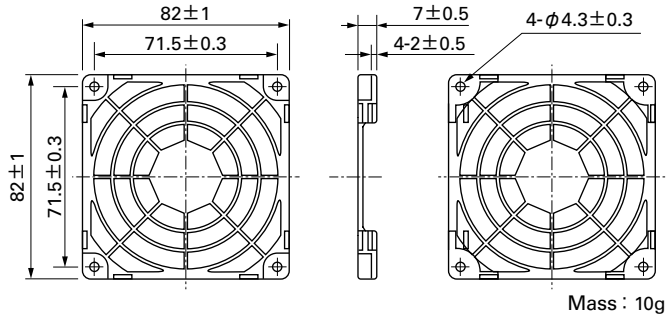

Model : 109-049E Color : Nickel-chrome plating (silver)
 Surface treatment : Nickel-chrome plating (silver)
 : 109-049H Color : Cation electropainting (black)

Resin Filter Kits

Model : 109-1002F13 (13PPI), 109-1002F20 (20PPI)
 : 109-1002F30 (30PPI), 109-1002F40 (40PPI)

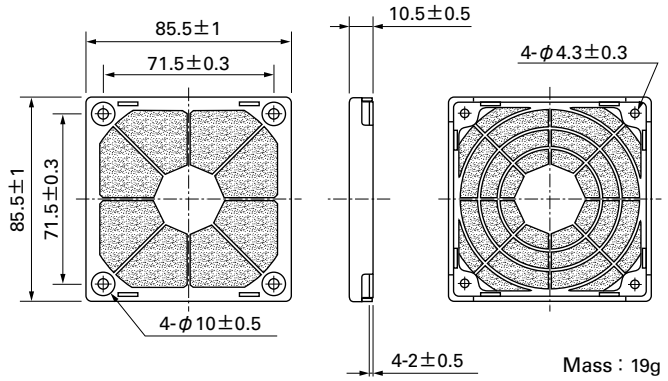
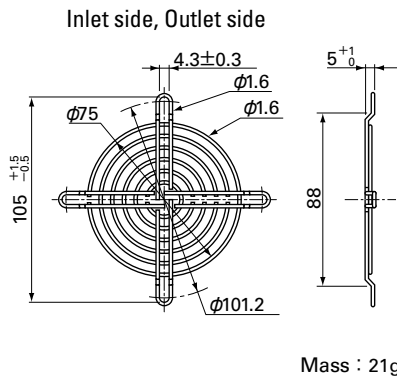

Airflow - Static Pressure Characteristics

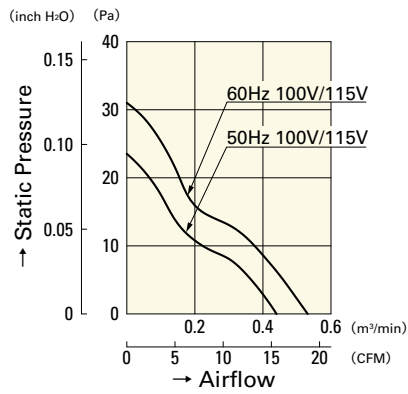

109-210

109-213

80 mm sq.

San Ace 80



General Specifications

- Material Frame: Aluminum,
Impeller:Plastics (Flammability: UL94V-1)
- Expected Life Refer to specifications (L10:Survival rate: 90% at 60°C ,
rated voltage,and continuously run in a free air state)
- Dielectric Strength 50/60Hz 1,500VAC 1minute (between input terminal and frame)
- Storage Temperature -30°C to +70°C (Non-condensing)
- Operating Voltage Range Voltage of each model ± 10%

80×80×25mm (Mass : 270g)

Specifications

Model No.	Rated Voltage [V]	Frequency [Hz]	Input [W]	Current [A]	Locked Rotor Current [A]	Rated Speed [min ⁻¹]	Max. Airflow [m ³ /min] [CFM]	Max. Static Pressure [Pa] [inchHzO]	SPL [dB(A)]	Operating Temperature [°C]	Expected Life [h]
109S050	100	50/60	9/7	0.12/0.1	0.13/0.11	2,650/3,100	0.63/0.76 22.3/26.9	27.5/38.3 0.110/0.154	30/33	-30 to +60	25,000/60°C
109S053	115			0.1 /0.08	0.11/0.09						
109S051	200			0.06/0.05	0.06/0.05						
109S054	230			0.05/0.04	0.05/0.04						
109S030	100			0.12/0.1	0.13/0.11	2,350/2,700	0.55/0.63 19.4/22.3	21.6/28.4 0.087/0.114	28/30		
109S033	115			0.1 /0.08	0.11/0.09						
109S031	200			0.06/0.05	0.06/0.05						
109S034	230			0.05/0.04	0.05/0.04						

Set Models Fan, finger guard, plug cord, screws, etc. can be purchased in one package. For details, please refer to pp. 453 to 456.

Dimensions (unit: mm)

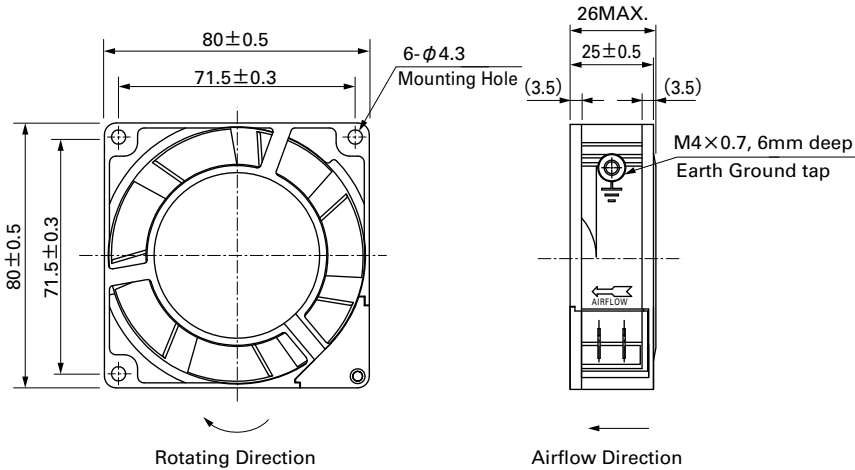

Reference Dimensions of Mounting Holes and Vent Opening (unit: mm)

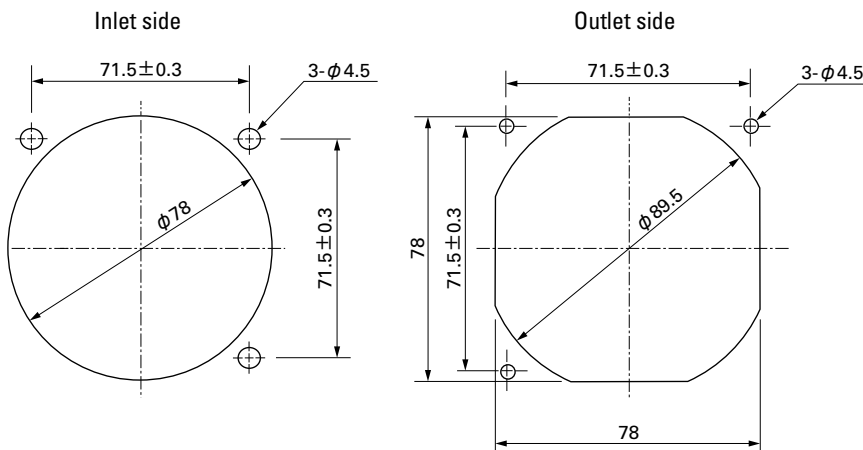

Wiring Diagram

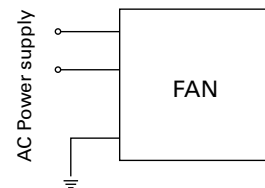

Options (unit: mm)

Finger Guards

Model : 109-049C Surface treatment : Nickel-chrome plating (silver) Color : Nickel-chrome plating (silver)

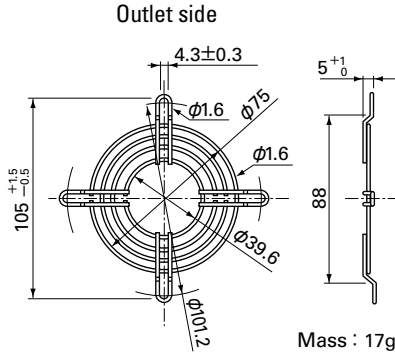

Resin Finger Guards

Model : 109-1002G

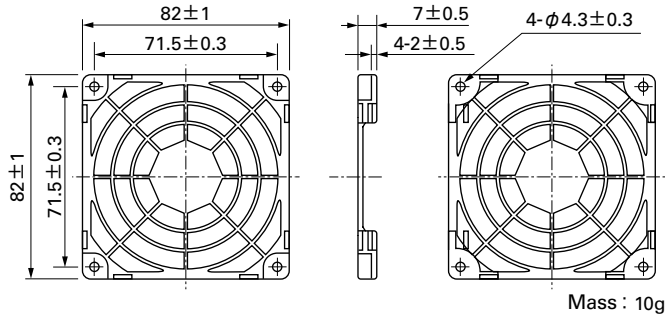

Model : 109-049E Surface treatment : Nickel-chrome plating (silver) Color : Nickel-chrome plating (silver)
Model : 109-049H Surface treatment : Cation electropainting (black) Color : Cation electropainting (black)

Resin Filter Kits

Model : 109-1002F13 (13PPI), 109-1002F20 (20PPI)
Model : 109-1002F30 (30PPI), 109-1002F40 (40PPI)

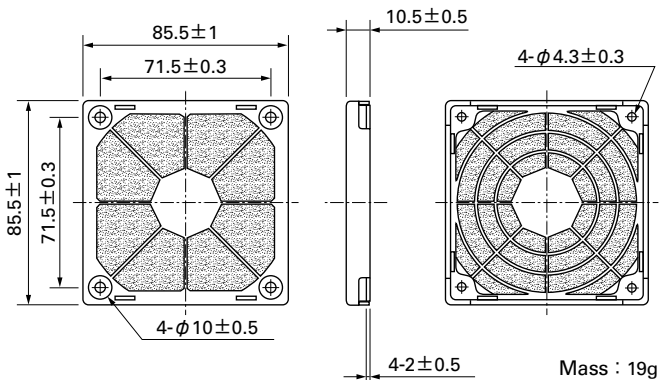
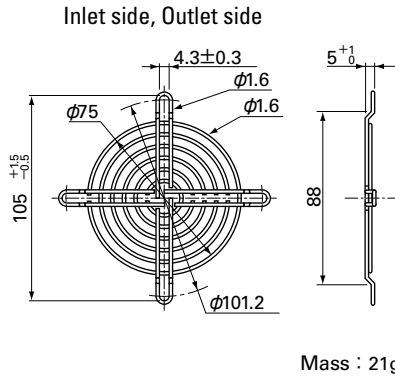

Plug Cord

(Products compliant with Electrical Appliance and Material Safety Law)
Model : 489-016-L10/489-016-L21

(UL/CSA CERTIFIED)
UL FILE No.E50197 CSA FILE No.LR67048
Model : 489-047-L10/489-047-L21

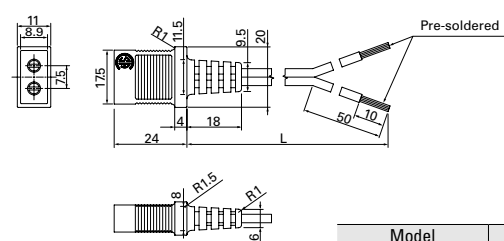
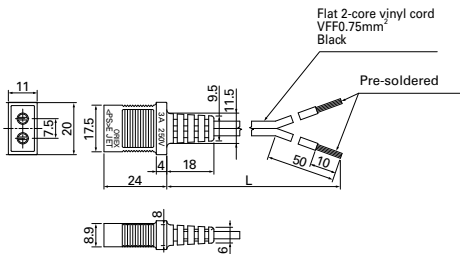

Model	Power cord length (L) [mm]	Mass [g]
489-016-L10	1,000	34
489-016-L21	2,100	64
489-047-L10	1,000	38
489-047-L21	2,100	71

Airflow - Static Pressure Characteristics

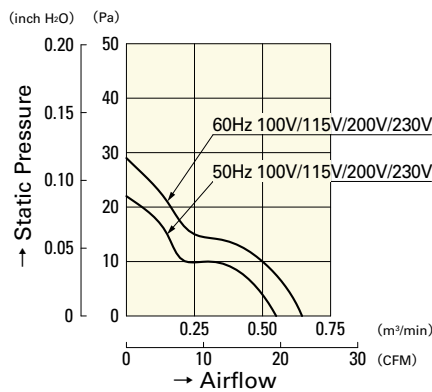
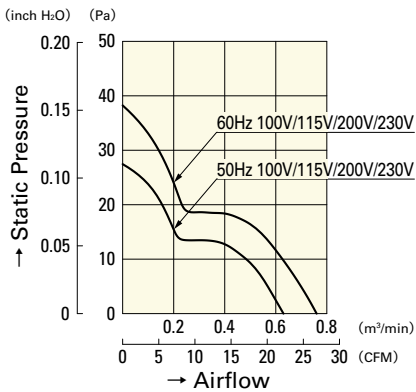

109S050
109S053
109S051
109S054

109S030
109S033
109S031
109S034

80mm sq.

San Ace 80



General Specifications

- Material..... Frame: Aluminum,
Impeller:Plastics (Flammability: UL94V-1)
- Expected Life Refer to specifications (L10:Survival rate: 90% at 60°C ,
rated voltage,and continuously run in a free air state)
- Dielectric Strength 50/60Hz 1,500VAC 1minute (between input terminal and frame)
- Storage Temperature -30°C to +70°C (Non-condensing)
- Operating Voltage Range Voltage of each model ± 10%

80×80×38mm [Mass : 400g]

Specifications

Model No.	Rated Voltage [V]	Frequency [Hz]	Input [W]	Current [A]	Locked Rotor Current [A]	Rated Speed [min ⁻¹]	Max. Airflow [m ³ /min] [CFM]	Max. Static Pressure [Pa] [inchHzO]	SPL [dB(A)]	Operating Temperature [°C]	Expected Life [h]
109-150	100	50/60	9/8	0.13/0.11	0.17/0.15	2,700/3,150	0.9/1.05 31.8/37.1	31.4/44.1 0.126/0.177	35/39	-30 to +60	25,000/60°C
109-153	115			0.11/0.1	0.14/0.12						
109-151	200			0.07/0.06	0.09/0.08						
109-154	230			0.06/0.05	0.08/0.07						

Set Models Fan, finger guard, plug cord, screws, etc. can be purchased in one package. For details, please refer to pp. 453 to 456.

Dimensions (unit: mm)

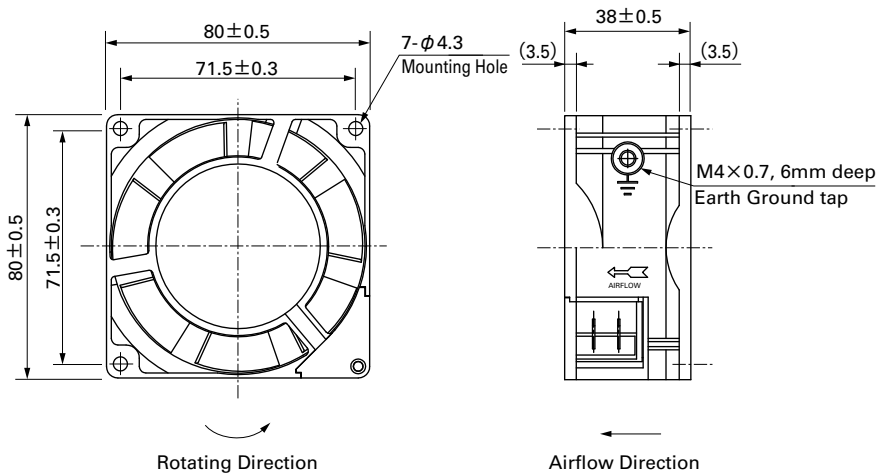

Reference Dimensions of Mounting Holes and Vent Opening (unit: mm)

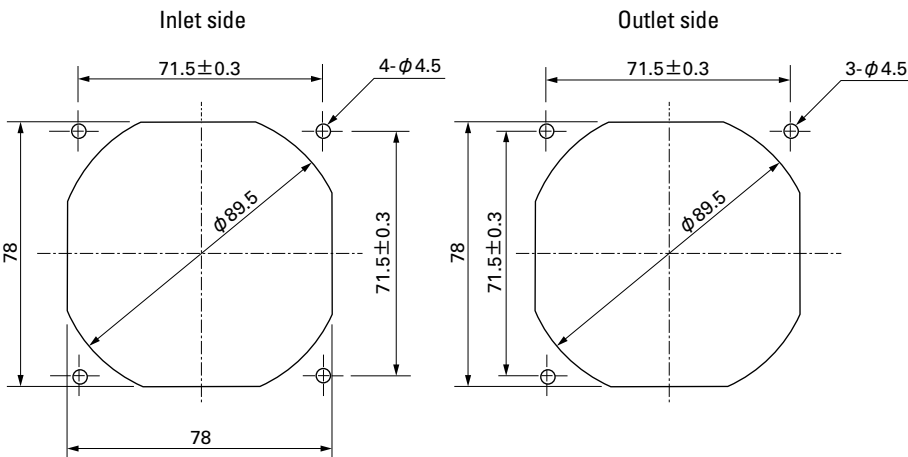

Wiring Diagram

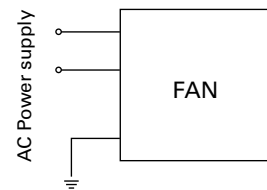

Options (unit: mm)

Finger Guards

Model : 109-049C Surface treatment : Nickel-chrome plating (silver) Color : Nickel-chrome plating (silver)

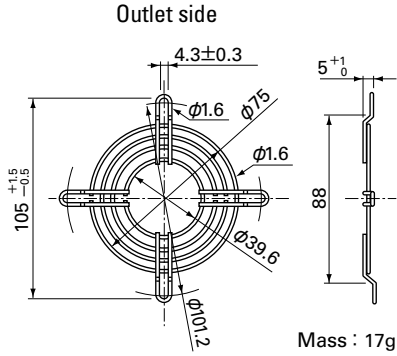

Resin Finger Guards

Model : 109-1002G

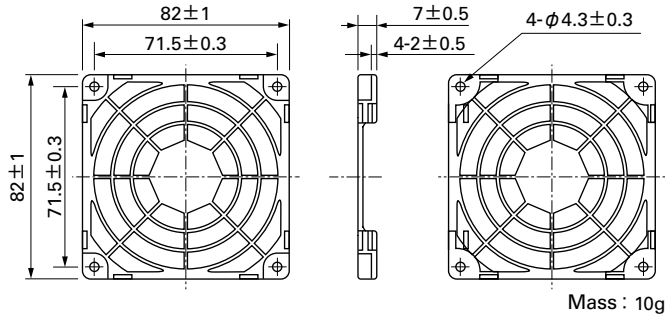

Model : 109-049E Surface treatment : Nickel-chrome plating (silver) Color : Nickel-chrome plating (silver)
Model : 109-049H Surface treatment : Cation electropainting (black) Color : Cation electropainting (black)

Resin Filter Kits

Model : 109-1002F13 (13PPI), 109-1002F20 (20PPI)
Model : 109-1002F30 (30PPI), 109-1002F40 (40PPI)

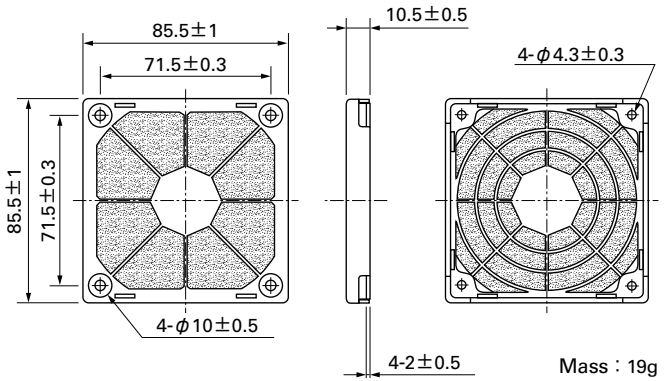
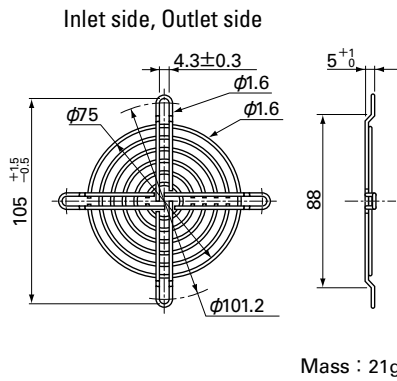

Plug Cord

(Products compliant with Electrical Appliance and Material Safety Law)
Model : 489-016-L10/489-016-L21

(UL/CSA CERTIFIED)
UL FILE No.E50197 CSA FILE No.LR67048
Model : 489-047-L10/489-047-L21

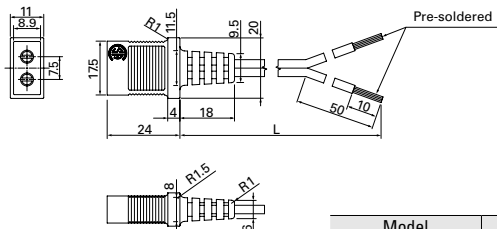
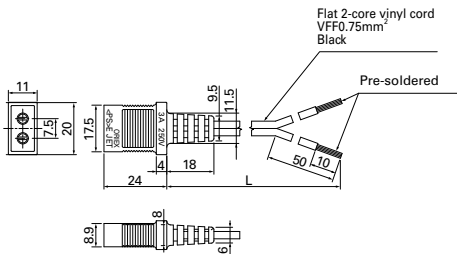

Model	Power cord length (L) [mm]	Mass [g]
489-016-L10	1,000	34
489-016-L21	2,100	64
489-047-L10	1,000	38
489-047-L21	2,100	71

Airflow - Static Pressure Characteristics

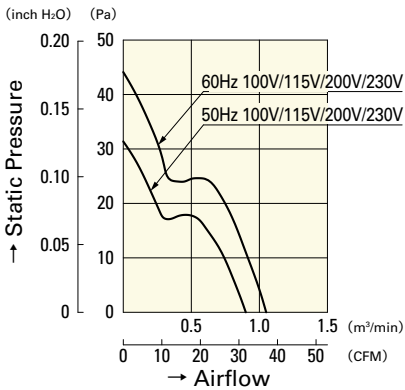

- 109-150**
- 109-153**
- 109-151**
- 109-154**

80 mm sq.

San Ace 80



General Specifications

- Material Frame: Aluminum,
Impeller:Plastics (Flammability: UL94V-1)
- Expected Life Refer to specifications (L10:Survival rate: 90% at 60°C ,
rated voltage,and continuously run in a free air state)
- Dielectric Strength 50/60Hz 1,500VAC 1minute (between input terminal and frame)
- Storage Temperature -30°C to +70°C (Non-condensing)
- Operating Voltage Range Voltage of each model ± 10%

80×80×42mm (Mass : 410g)

Specifications

Model No.	Rated Voltage [V]	Frequency [Hz]	Input [W]	Current [A]	Locked Rotor Current [A]	Rated Speed [min ⁻¹]	Max. Airflow [m ³ /min] [CFM]	Max. Static Pressure [Pa] [inchHzO]	SPL [dB(A)]	Operating Temperature [°C]	Expected Life [h]
109-040UL	100	50/60	10/9	0.13/0.11	0.16/0.14	2,650/3,100	0.85/1.0 30.0/35.3	24.5/35.3 0.098/0.142	40/44	-30 to +60	25,000/60°C
109-043UL	115			0.11/0.1	0.14/0.12						
109-041UL	200			0.07/0.06	0.08/0.07						
109-044UL	230			0.06/0.05	0.07/0.06						
109-047UL	100		4/3.5	0.05/0.05	0.05/0.05	1,500/1,500	0.43/0.43 15.2/15.2	8.8/8.8 0.035/0.035	24/24		
109-033UL	115	0.04/0.04		0.04/0.04							

Set Models Fan, finger guard, plug cord, screws, etc. can be purchased in one package. For details, please refer to pp. 453 to 456.

Dimensions (unit: mm)

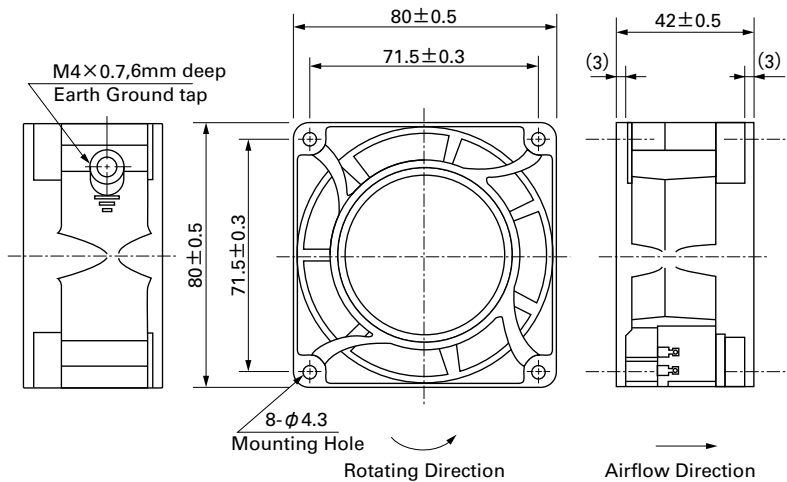

Reference Dimensions of Mounting Holes and Vent Opening (unit: mm)

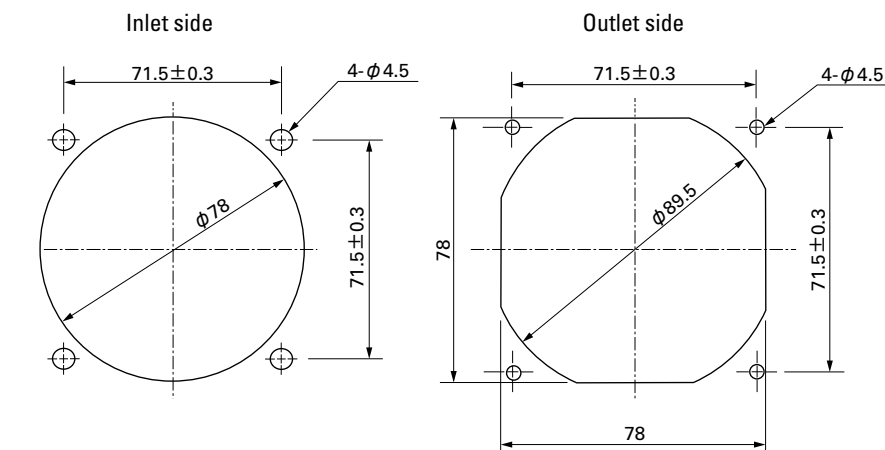

Wiring Diagram

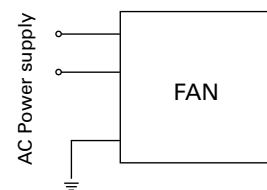

Options (unit: mm)

Finger Guards

Model : 109-049C Color Surface treatment : Nickel-chrome plating (silver)

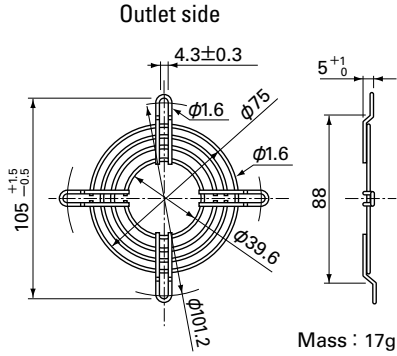

Resin Finger Guards

Model : 109-1002G

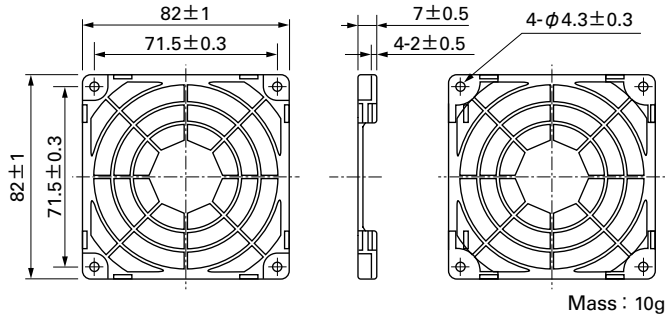

Model : 109-049E Color Surface treatment : Nickel-chrome plating (silver)
Model : 109-049H : Cation electropainting (black)

Resin Filter Kits

Model : 109-1002F13 (13PPI), 109-1002F20 (20PPI)
Model : 109-1002F30 (30PPI), 109-1002F40 (40PPI)

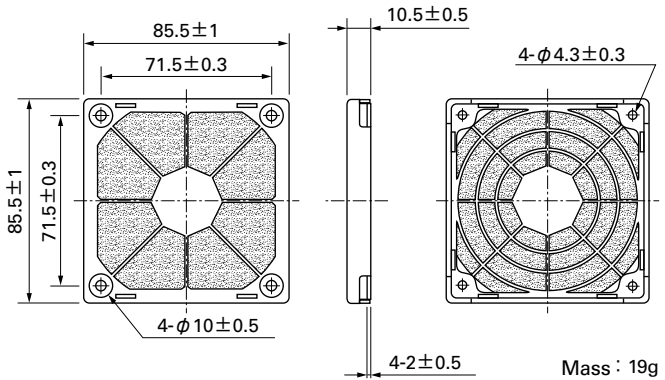
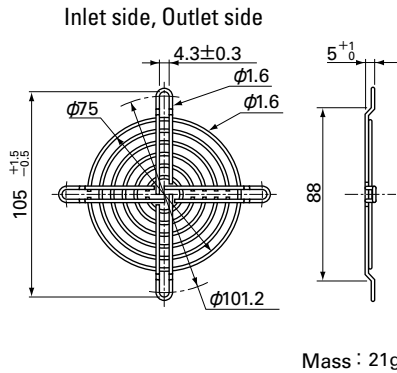

Plug Cord

(Products compliant with Electrical Appliance and Material Safety Law)
Model : 489-008-L10/489-008-L21/489-008-L35

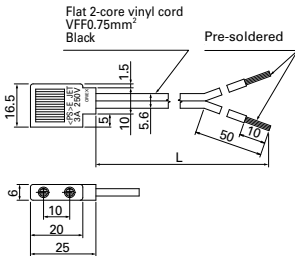

Model	Power cord length (L) [mm]	Mass [g]
489-008-L10	1,000	30
489-008-L21	2,100	61
489-008-L35	3,500	99

Airflow - Static Pressure Characteristics

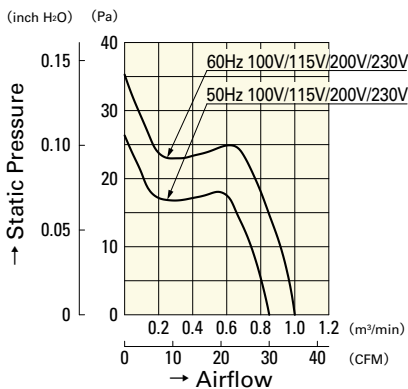

109-040UL
109-043UL
109-041UL
109-044UL

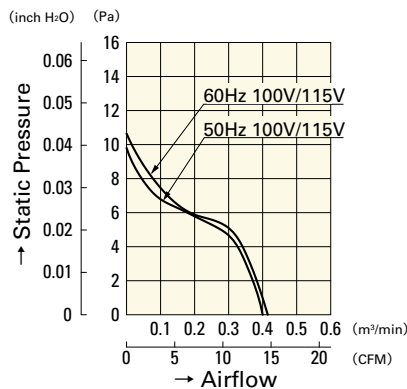

109-047UL
109-033UL

92mm sq.

San Ace 92



Only standard fans (without sensors) have acquired CSA certification.

General Specifications

- Material..... Frame: Aluminum, Impeller: Plastics (Flammability: UL94V-1)
- Expected Life Refer to specifications (L10:Survival rate: 90% at 60°C , rated voltage,and continuously run in a free air state)
- Dielectric Strength 50/60Hz 1,500VAC 1minute (between input terminal and frame)
- Dielectric Strength (With Sensor) ... Between AC input and DC input(Sensor output)
 - : 50/60Hz 1,000VAC 1minute
 - Between AC input and G
 - : 50/60Hz 1,500VAC 1minute,
 - Between G and DC input(Sensor output)
 - : 50/60Hz 1,000VAC 1minute
- Sensor-Purpose Lead Wire ... ⊕ brown ⊖ black (Sensor) yellow
- Storage Temperature -30°C to +70°C (Non-condensing)
- Operating Voltage Range ... Voltage of each model ±10%

92×92×25mm (Mass : 290g / 310g (with Sensor))

Specifications Standard

Model No.	Rated Voltage [V]	Frequency [Hz]	Input [W]	Current [A]	Locked Rotor Current [A]	Rated Speed [min ⁻¹]	Max. Airflow [m ³ /min] [CFM]	Max. Static Pressure [Pa] [inchH ₂ O]	SPL [dB(A)]	Operating Temperature [°C]	Expected Life [h]
109S091	100	50/60	8/7	0.1 /0.09	0.13/0.12	2,700/3,100	0.95/1.1 33.6/38.9	39.2/49.0 0.157/0.197	35/38	-30 to +60	25,000/60°C
109S093	115			0.09/0.08	0.11/0.1						
109S092	200		11/10	0.07/0.06	0.08/0.08						
109S094	230		10/9	0.06/0.05	0.07/0.07						
109S095	100		8/7	0.1 /0.09	0.11/0.1	2,400/2,800	0.84/0.98 29.7/34.6	31.4/40.2 0.126/0.161	32/35		
109S096	100		7/6	0.09/0.08	0.09/0.08	1,500/1,700	0.55/0.65 19.4/23	12.5/16.3 0.050/0.065	24/27		
109S193	115			0.08/0.07	0.08/0.07						
109S192	200		8/7	0.06/0.05	0.06/0.05						
109S194	230			0.05/0.04	0.05/0.04						

with Sensor

Model No.	Rated Voltage [V]	Frequency [Hz]	Input [W]	Current [A]	Locked Rotor Current [A]	Rated Speed [min ⁻¹]	Max. Airflow [m ³ /min] [CFM]	Max. Static Pressure [Pa] [inchH ₂ O]	SPL [dB(A)]	Operating Temperature [°C]	Expected Life [h]
109S491	100	50/60	8/7	0.1 /0.09	0.13/0.12	2,700/3,100	0.95/1.1 33.6/38.9	39.2/49.0 0.157/0.197	35/38	-10 to +60	25,000/60°C
109S493	115			0.09/0.08	0.11/0.1						
109S492	200		11/10	0.07/0.06	0.08/0.08						
109S494	230		10/9	0.06/0.05	0.07/0.07						
109S495	100		8/7	0.1 /0.09	0.11/0.1	2,400/2,800	0.84/0.98 29.7/34.6	31.4/40.2 0.126/0.161	32/35		
109S496			7/6	0.09/0.08	0.09/0.08	1,500/1,700	0.55/0.65 19.4/23	12.5/16.3 0.050/0.065	24/27		

Two types of power supplies, 5V (ITEM-20) and 12V (ITEM-30), are available in fans with sensor attached.

- Set Models** Fan, finger guard, plug cord, screws, etc. can be purchased in one package. For details, please refer to pp. 453 to 456.

Dimensions (unit: mm)

Standard

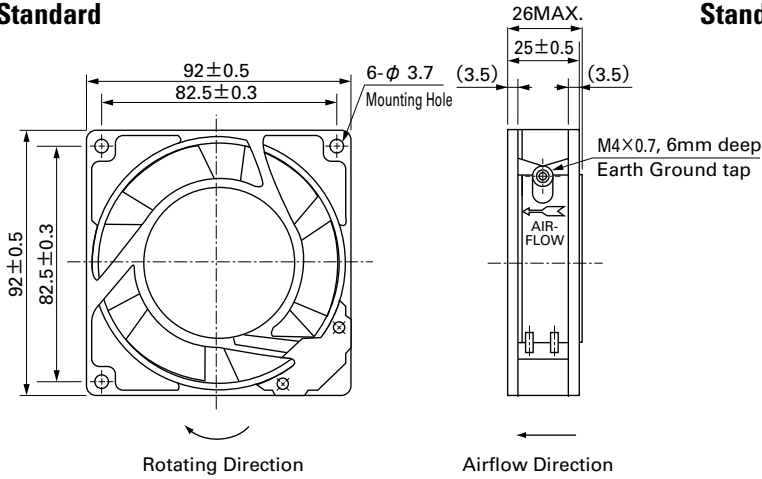

Reference Dimensions of Mounting Holes and Vent Opening (unit: mm)

Standard

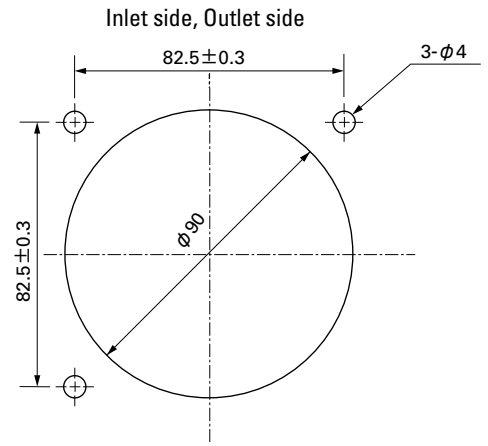

with Sensor

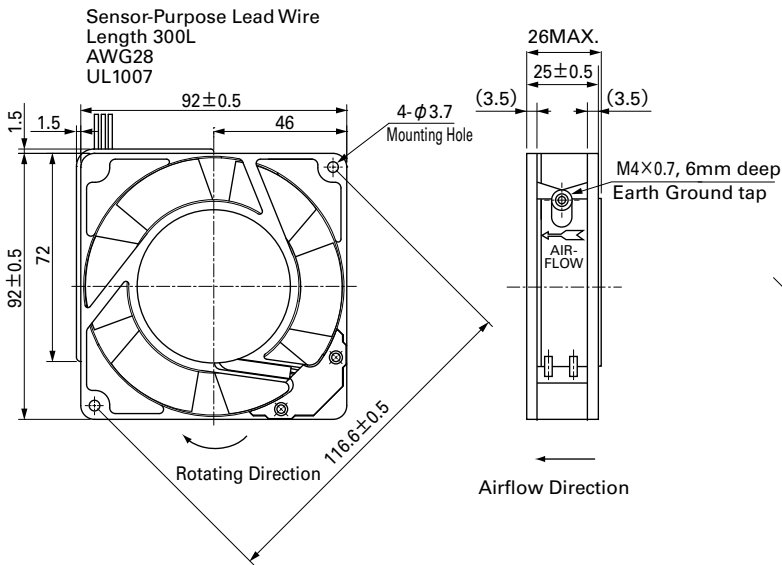

with Sensor

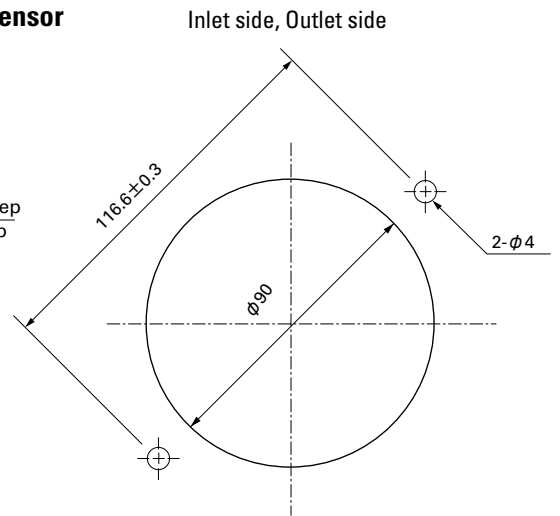

AC
AC Fan 92mm

Wiring Diagram

Standard

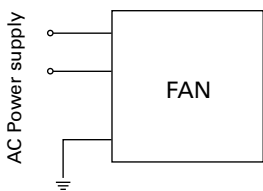

with Sensor

(For fan power supply)

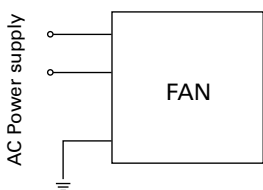

5V (ITEM-20)

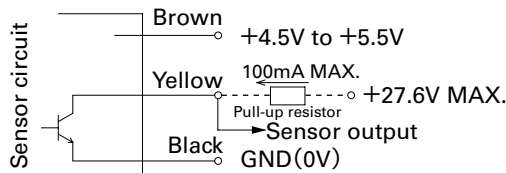

12V (ITEM-30)

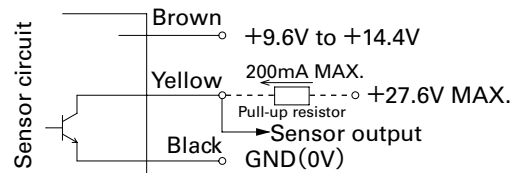

GND (Black) should be shared in case that power supply for sensor circuit (Brown) and that for sensor pull-up (Yellow) are separated.

92 mm sq.

San Ace 92

92×92×25mm [Mass : 290g / 310g (with Sensor)]

Options (unit: mm)

Finger Guards

Model : 109-099C Surface treatment : Nickel-chrome plating (silver) Color

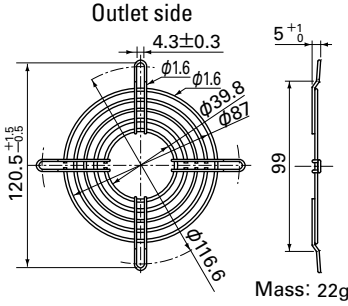

Resin Finger Guards

Model : 109-1001G

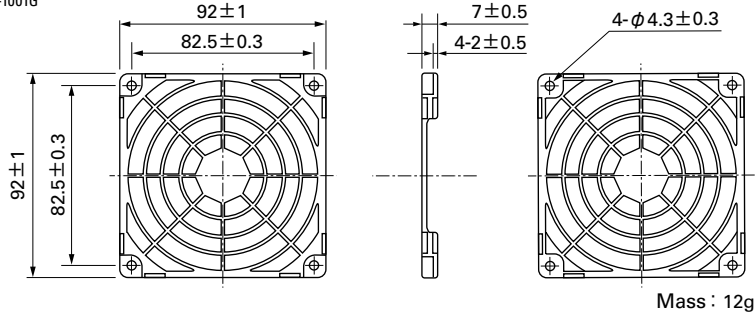

Model : 109-099E Surface treatment : Nickel-chrome plating (silver) Color
 : 109-099H : Cation electroplating (black)

Inlet side, Outlet side

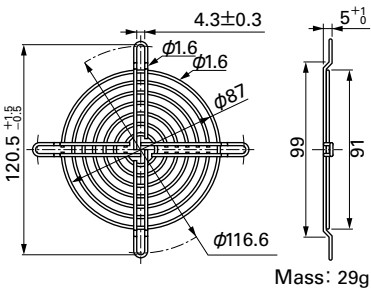

Resin Filter Kits

Model : 109-1001F13 (13PPI), 109-1001F20 (20PPI)
 : 109-1001F30 (30PPI), 109-1001F40 (40PPI)

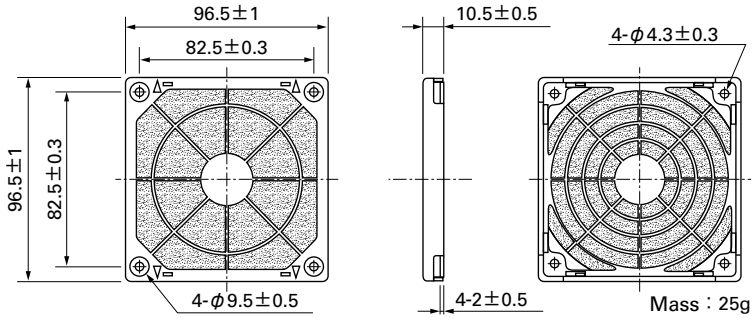

Plug Cord

(Products compliant with Electrical Appliance and Material Safety Law)
 Model : 489-016-L10/489-016-L21

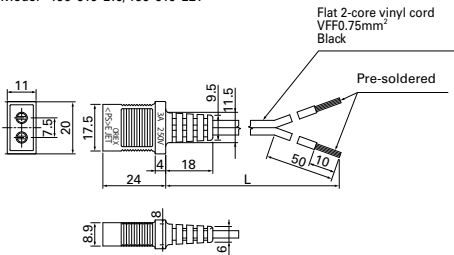

(UL/CSA CERTIFIED)
 UL FILE No.E50197 CSA FILE No.LR67048
 Model : 489-047-L10/489-047-L21

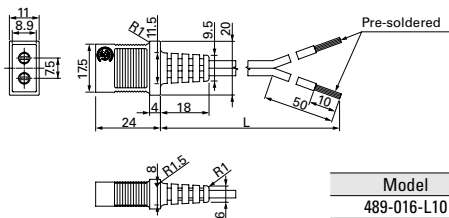

Model	Power cord length (L) [mm]	Mass [g]
489-016-L10	1,000	34
489-016-L21	2,100	64
489-047-L10	1,000	38
489-047-L21	2,100	71

Airflow - Static Pressure Characteristics

Standard

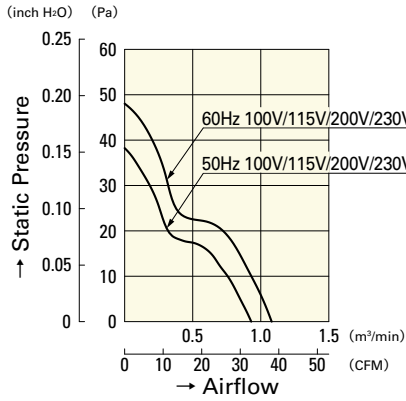

109S091

109S093

109S092

109S094

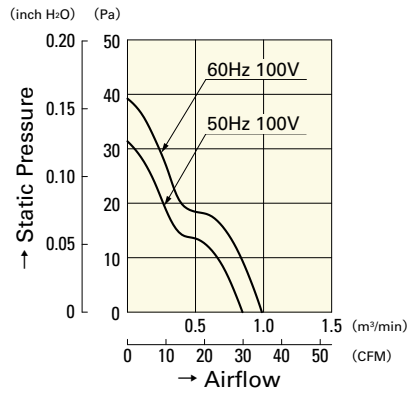

109S095

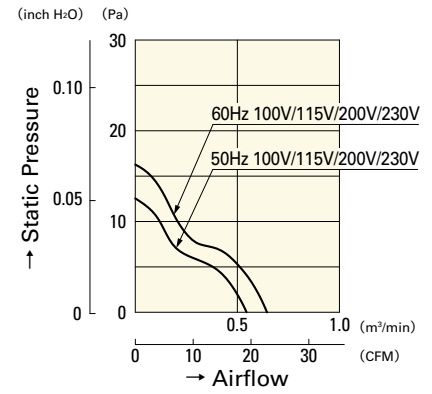

109S096

109S193

109S192

109S194

with Sensor

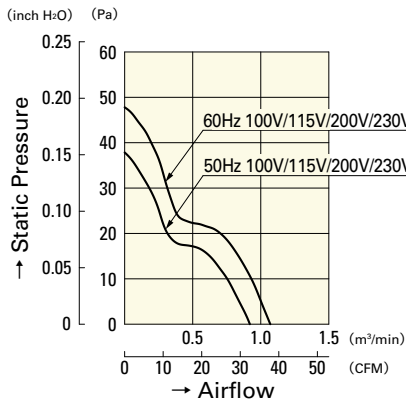

109S491

109S493

109S492

109S494

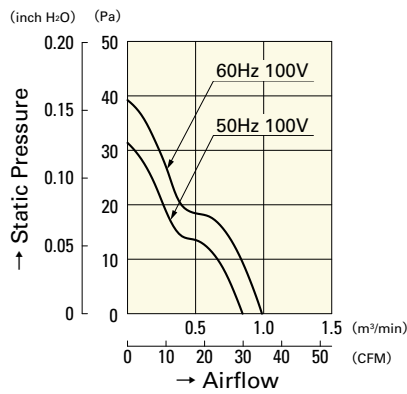

109S495

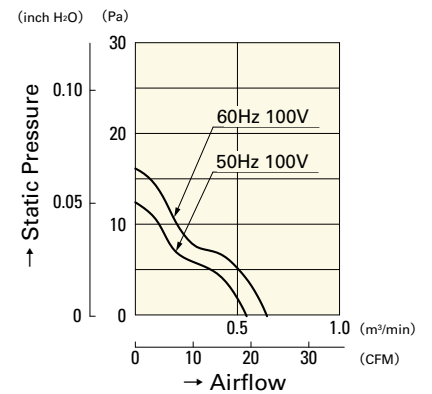

109S496

120mm sq.

San Ace 120



Only standard fans (without sensors) have acquired CSA certification.

General Specifications

- Material..... Frame: Aluminum,
Impeller: Plastics (Flammability: UL94V-1)
- Expected Life Refer to specifications (L10:Survival rate: 90% at 60°C ,
rated voltage,and continuously run in a free air state)
- Dielectric Strength 50/60Hz 1,500VAC 1minute (between input terminal and frame)
- Dielectric Strength (With Sensor) ... Between AC input and DC input(Sensor output)
: 50/60Hz 1,000VAC 1minute
Between AC input and G
: 50/60Hz 1,500VAC 1minute,
Between G and DC input(Sensor output)
: 50/60Hz 1,000VAC 1minute
- Sensor-Purpose Lead Wire ... ⊕ brown ⊖ black (Sensor) yellow
- Storage Temperature -30°C to+70°C (Non-condensing)
- Operating Voltage Range ... Voltage of each model ±10%

120×120×25mm [Mass : 370g / 390g (with Sensor)]

Specifications Standard

Model No.	Rated Voltage [V]	Frequency [Hz]	Input [W]	Current [A]	Locked Rotor Current [A]	Rated Speed [min ⁻¹]	Max. Airflow [m ³ /min] [CFM]	Max. Static Pressure [Pa] [inchHzO]	SPL [dB(A)]	Operating Temperature [°C]	Expected Life [h]
109S085	100	50/60	13.5/12	0.16/0.14	0.19/0.17	2,500/2,900	1.95/2.3 68.9/81.3	48 /51.9 0.193/0.216	38/41	-30 to +60	25,000/60°C
109S084	115			0.14/0.12	0.16/0.15						
109S088	200			0.08/0.07	0.1 /0.09						
109S087	230			0.07/0.06	0.08/0.07						
109S081	100		9.5/8.5	0.11	0.11/0.1	2,200/2,350	1.7 /1.8 60.1/63.6	29.4/26.5 0.118/0.106	34/35		
109S083	115		0.1	0.1 /0.09							
109S082	200		0.07	0.07/0.06							
109S089	230		0.06	0.06/0.05							
109S086	100	12/10	0.14/0.12	0.15/0.13	1,400/1,600	1.1 /1.25 38.9/44.2	14.7/18.6 0.059/0.075	24/27			

with Sensor

Model No.	Rated Voltage [V]	Frequency [Hz]	Input [W]	Current [A]	Locked Rotor Current [A]	Rated Speed [min ⁻¹]	Max. Airflow [m ³ /min] [CFM]	Max. Static Pressure [Pa] [inchHzO]	SPL [dB(A)]	Operating Temperature [°C]	Expected Life [h]
109S485	100	50/60	13.5/12	0.16/0.14	0.19/0.17	2,500/2,900	1.95/2.3 68.9/81.3	48 /51.9 0.193/0.216	38/41	-10 to +60	25,000/60°C
109S484	115			0.14/0.12	0.16/0.15						
109S488	200			0.08/0.07	0.1 /0.09						
109S487	230			0.07/0.06	0.08/0.07						
109S486	100		12/10	0.14/0.12	0.15/0.13	1,400/1,600	1.1 /1.25 38.9/44.2	14.7/18.6 0.059/0.075	24/27		

Two types of power supplies, 5V (ITEM-20) and 12V (ITEM-30), are available in fans with sensor attached.

- Set Models** Fan, finger guard, plug cord, screws, etc. can be purchased in one package.
For details, please refer to pp. 453 to 456.

■ Dimensions (unit: mm)

Standard

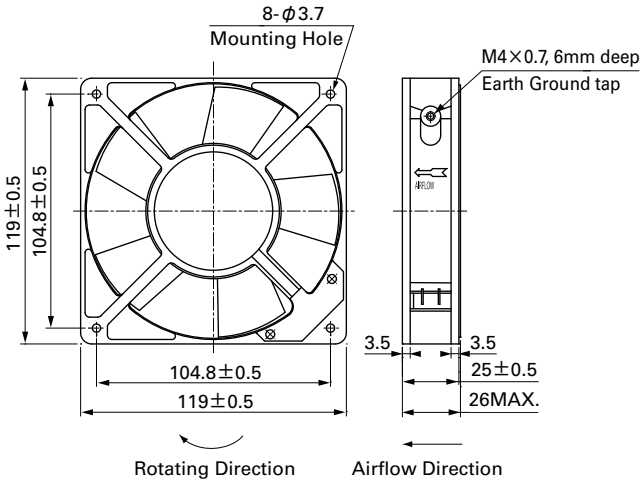

■ Reference Dimensions of Mounting Holes and Vent Opening (unit: mm)

Inlet side, Outlet side

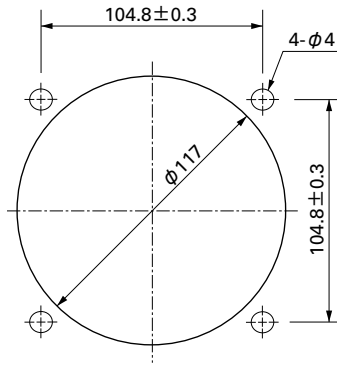

with Sensor

When mounting the model with a sensor, please screw-mount through both flanges as it has a sensor box.

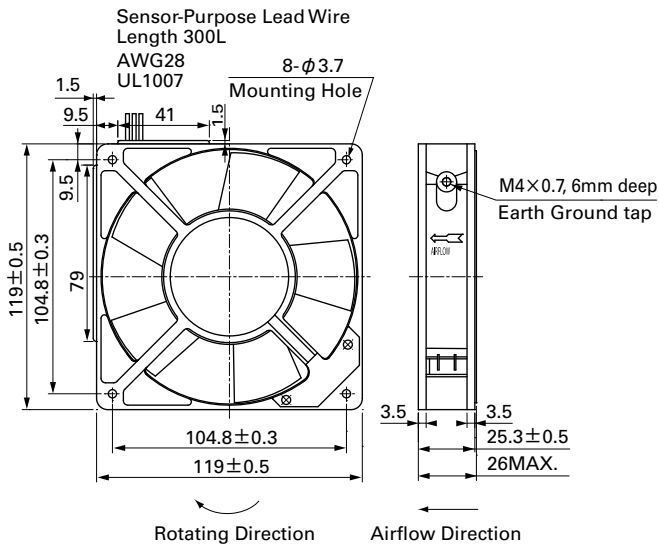

AC
AC Fan 120mm

■ Wiring Diagram

Standard

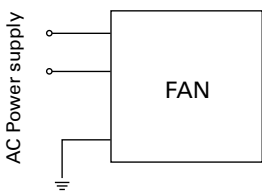

with Sensor

(For fan power supply)

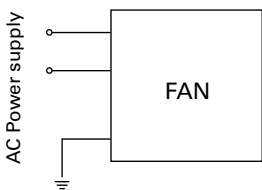

5V (ITEM-20)

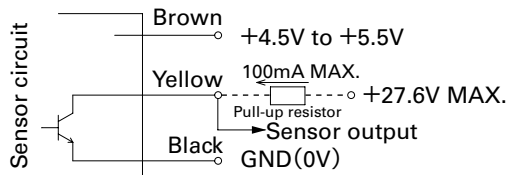

12V (ITEM-30)

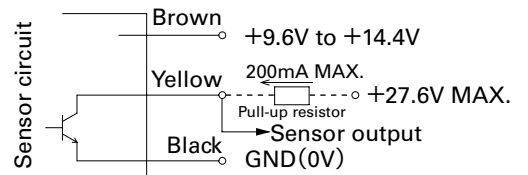

GND (Black) should be shared in case that power supply for sensor circuit (Brown) and that for sensor pull-up (Yellow) are separated.

120 mm sq.

San Ace 120

120×120×25 mm (Mass : 370g / 390g (with Sensor))

Options (unit: mm)

Finger Guards

Model : 109-019C Surface treatment : Nickel-chrome plating (silver) Color
 : 109-019H : Cation electropainting (black)

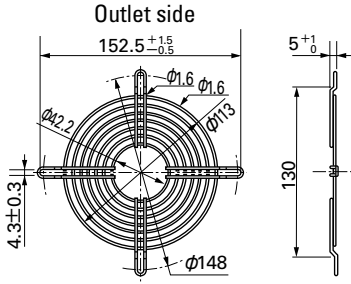

Mass : 32g

Resin Finger Guards

Model : 109-1000G

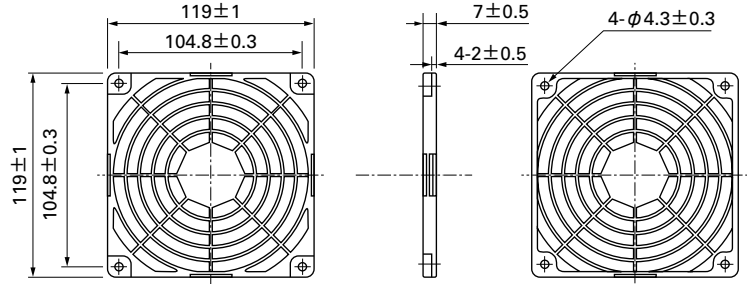

Mass : 23g

Model : 109-019E Surface treatment : Nickel-chrome plating (silver) Color
 : 109-019K : Cation electropainting (black)

Inlet side, Outlet side

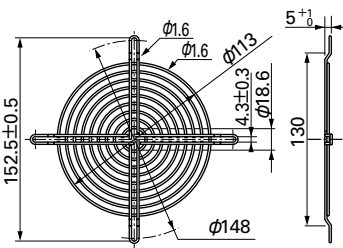

Mass : 42g

Resin Filter Kits

Model : 109-1000F13 (13PPI), 109-1000F20 (20PPI)
 : 109-1000F30 (30PPI), 109-1000F40 (40PPI)

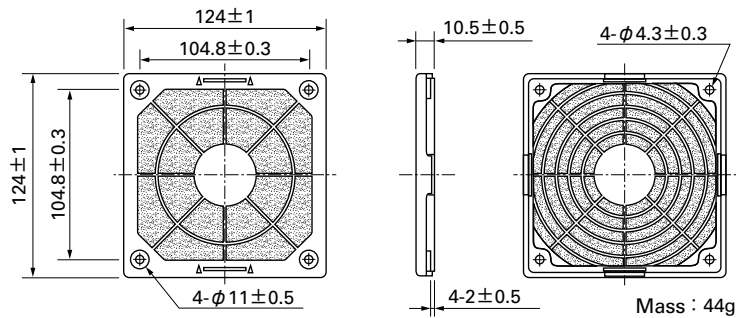

Mass : 44g

Plug Cord

(Products compliant with Electrical Appliance and Material Safety Law)
 Model : 489-016-L10/489-016-L21

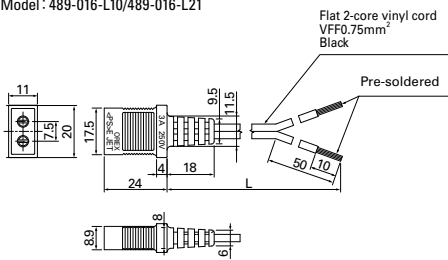

(UL/CSA CERTIFIED)
 UL FILE No.E50197 CSA FILE No.LR67048
 Model : 489-047-L10/489-047-L21

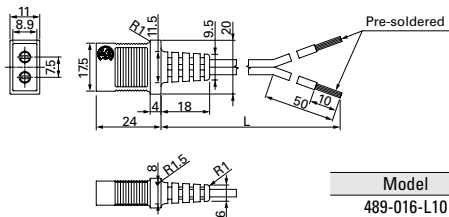

Model	Power cord length (L) [mm]	Mass [g]
489-016-L10	1,000	34
489-016-L21	2,100	64
489-047-L10	1,000	38
489-047-L21	2,100	71

Airflow - Static Pressure Characteristics

Standard

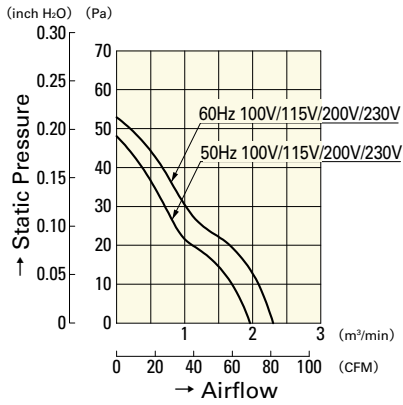

109S085

109S084

109S088

109S087

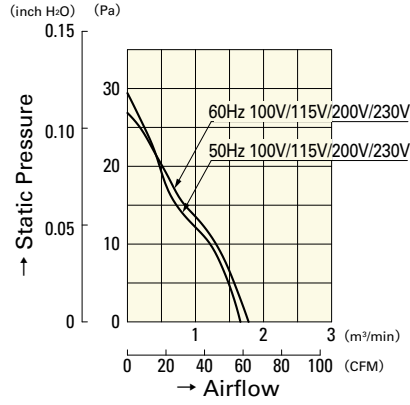

109S081

109S083

109S082

109S089

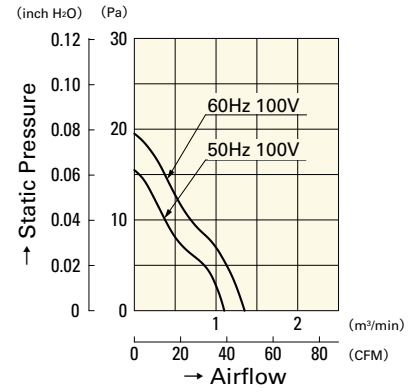

109S086

with Sensor

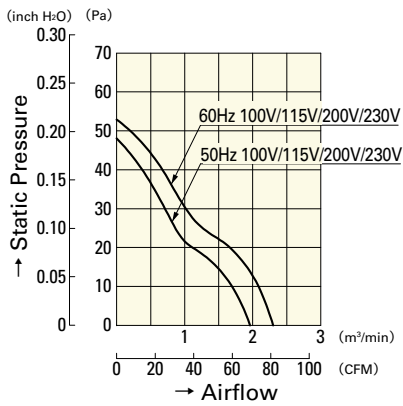

109S485

109S484

109S488

109S487

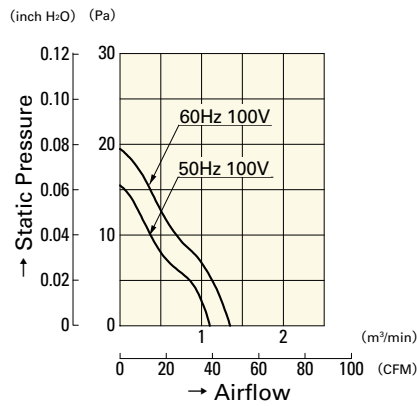

109S486

120mm sq.**San Ace 120**

Certifications vary by model no.
Please refer to pp. 514 to 515.

General Specifications

- Material..... Frame: Aluminum,
Impeller: Plastics (Flammability: UL94V-1)
- Expected Life Refer to specifications (L10:Survival rate: 90% at 60°C ,
rated voltage,and continuously run in a free air state)
- Dielectric Strength 50/60Hz 1,500VAC 1minute (between input terminal and frame)
- Dielectric Strength (With Sensor) ... Between AC input and DC input(Sensor output)
: 50/60Hz 1,000VAC 1minute
Between AC input and G
: 50/60Hz 1,500VAC 1minute,
Between G and DC input(Sensor output)
: 50/60Hz 1,000VAC 1minute
- Sensor-Purpose Lead Wire ... ⊕ brown ⊖ black (Sensor) yellow
- Storage Temperature -30°C to +70°C (Non-condensing)
- Operating Voltage Range ... Voltage of each model ±10%

120×120×38mm [Mass : 550g / 580g (with Sensor)]

Specifications Standard

Model No.	Rated Voltage [V]	Frequency [Hz]	Input [W]	Current [A]	Locked Rotor Current [A]	Rated Speed [min ⁻¹]	Max. Airflow [m ³ /min] [CFM]	Max. Static Pressure [Pa] [inchH ₂ O]	SPL [dB(A)]	Operating Temperature [°C]	Expected Life [h]
109S075UL	100	50/60	18/16	0.24/0.21	0.32/0.28	2,700/3,100	2.5 / 2.9 88.3/102.5	57.9/68.7 0.233/0.276	42/45	-30 to +60	25,000/60°C
109S074UL	115			0.21/0.18	0.27/0.24						
109S078UL	200			0.12/0.1	0.16/0.14						
109S072UL	230			0.11/0.09	0.14/0.13						
109S005	100		14/12	0.18/0.16	0.25/0.22	2,700/3,100	2.35/2.7 83 / 95.4	55.9/65.7 0.224/0.264	40/43		
109S005UL	100			0.16/0.14	0.21/0.18						
109S024	120			0.09/0.08	0.13/0.11						
109S024UL	115			0.08/0.07	0.11/0.09						
109S008	200		14/12	0.18/0.16	0.23/0.21	2,450/2,700	2.15/2.35 76 / 83	44.1/49.0 0.177/0.197	38/40		
109S008UL	200			0.16/0.14	0.16/0.15						
109S025	230			0.09/0.08	0.13/0.11						
109S025UL	230			0.08/0.07	0.11/0.09						
109S029UL	100		14/12	0.18/0.16	0.23/0.21	1,800/2,000	1.55/1.75 54.8/ 60.8	23.5/26.4 0.094/0.106	30/32		
109S013	100			0.16/0.14	0.16/0.15						
109S013UL	100			0.1 / 0.09	0.1 / 0.09						
109S006	115			0.13/0.11	0.13/0.11						
109S006UL	115	7/7	0.1 / 0.09	0.1 / 0.09	1,650/1,700	1.45/1.5 51.2/ 53	17.6/17.6 0.071/0.071	28/28			
109S010	200		0.13/0.11	0.13/0.11							
109S010UL	200		0.05/0.04	0.05/0.04							
109S010UL	240		0.06/0.05	0.06/0.05							
109S010UL	240	11/11	0.06/0.05	0.06/0.05	1,800/1,950	1.58/1.68 55.8/ 59.3	20.6/21.6 0.083/0.087	30/32			

with Sensor

Model No.	Rated Voltage [V]	Frequency [Hz]	Input [W]	Current [A]	Locked Rotor Current [A]	Rated Speed [min ⁻¹]	Max. Airflow [m ³ /min] [CFM]	Max. Static Pressure [Pa] [inchH ₂ O]	SPL [dB(A)]	Operating Temperature [°C]	Expected Life [h]
109S405UL	100	50/60	14/12	0.18/0.16	0.25/0.22	2,700/3,100	2.35/2.7 83/95.4	55.9/65.7 0.224/0.264	40/43	-10 to +60	25,000/60°C
109S424UL	115			0.16/0.14	0.21/0.18						
109S408UL	200			0.09/0.08	0.13/0.11						
109S425UL	230			0.08/0.07	0.11/0.09						
109S429UL	100		7/6	0.18/0.16	0.23/0.21	2,450/2,700	2.15/2.35 76/83	44.1/49.0 0.177/0.197	38/40		
109S406UL	100			0.09/0.08	0.1 / 0.09						
109S475UL	100			0.24/0.21	0.32/0.28						
109S474UL	115			0.21/0.18	0.27/0.24						
109S478UL	200		18/16	0.12/0.1	0.16/0.14	2,700/3,100	2.5 / 2.9 88.3/102.4	57.9/68.7 0.233/0.276	42/45		
109S472UL	230			0.11/0.09	0.14/0.13						

Two types of power supplies, 5V (ITEM-20) and 12V (ITEM-30), are available in fans with sensor attached.

- Set Models** Fan, finger guard, plug cord, screws, etc. can be purchased in one package.
For details, please refer to pp. 453 to 456.

Dimensions (unit: mm)

Standard

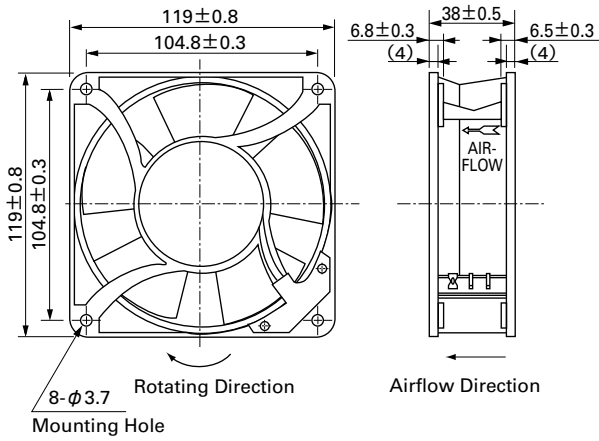

with Sensor

When mounting the model with a sensor, please screw-mount through both flanges as it has a sensor box.

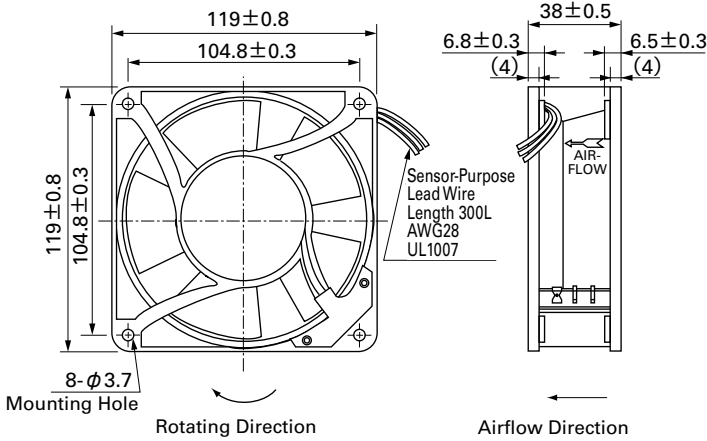

Reference Dimensions of Mounting Holes and Vent Opening (unit: mm)

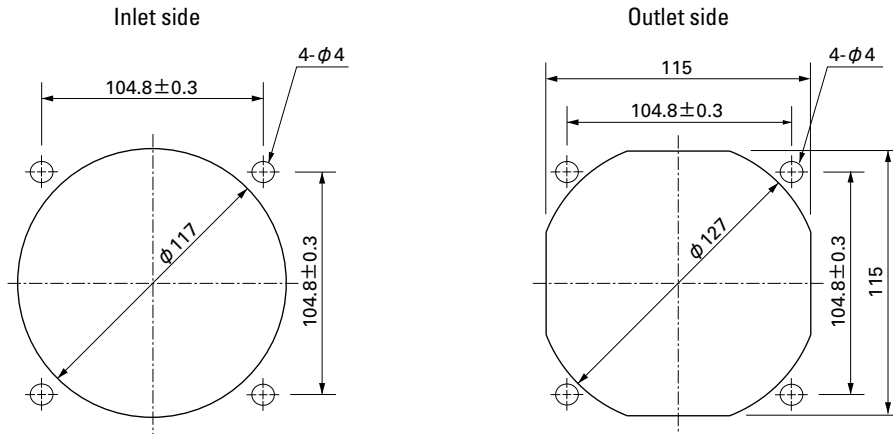

Wiring Diagram

Standard

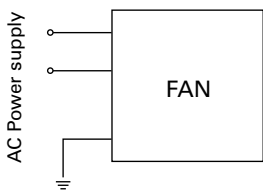

with Sensor

(For fan power supply)

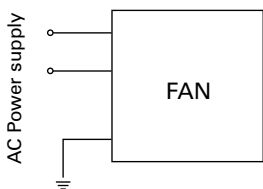

5V (ITEM-20)

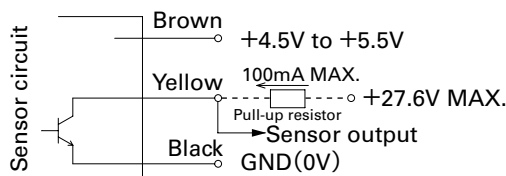

12V (ITEM-30)

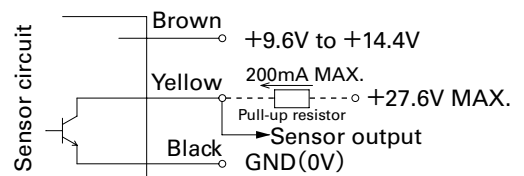

GND (Black) should be shared in case that power supply for sensor circuit (Brown) and that for sensor pull-up (Yellow) are separated.

120 mm sq.

San Ace 120

120×120×38mm [Mass : 550g / 580g (with Sensor)]

Options (unit: mm)

Finger Guards

Model : 109-019C Surface treatment : Nickel-chrome plating (silver) Color
: 109-019H : Cation electropainting (black)

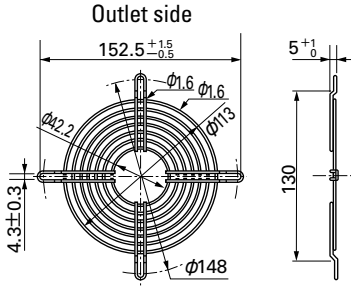

Mass : 32g

Resin Finger Guards

Model : 109-1000G

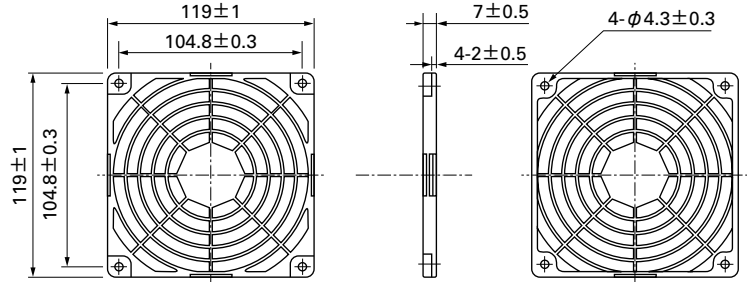

Mass : 23g

Model : 109-019E Surface treatment : Nickel-chrome plating (silver) Color
: 109-019K : Cation electropainting (black)

Inlet side, Outlet side

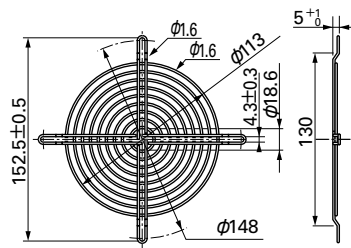

Mass : 42g

Resin Filter Kits

Model : 109-1000F13 (13PPI), 109-1000F20 (20PPI), 109-1000F30 (30PPI), 109-1000F40 (40PPI)

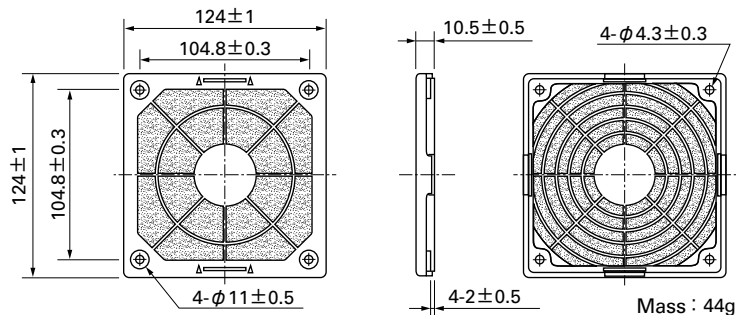

Mass : 44g

Filter Kits

Model : 109-018 Applicable models : AC Fan 120×120×38mm

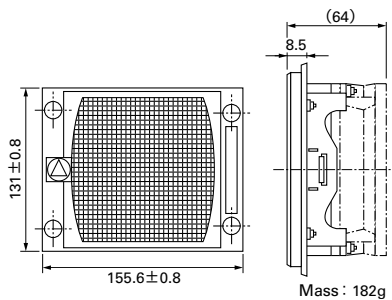

Mass : 182g

Screen Kits

Model : 109-020 Applicable models : AC Fan 120×120×38mm

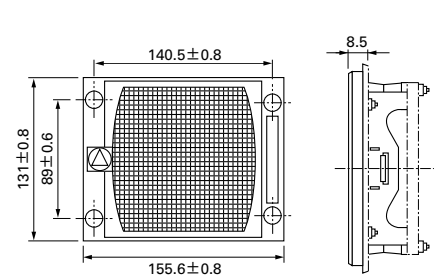

Mass : 135g

Neither filterkit nor screenkit can be installed on fans with sensor.

Plug Cord

Exclusive for fans without UL at the end of the model number.

(Products compliant with Electrical Appliance and Material Safety Law)
Model : 489-006-L10/489-006-L21/489-006-L35

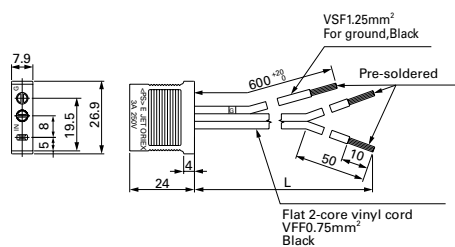

Model	Power cord length (L) [mm]	Mass [g]
489-006-L10	1,000	47
489-006-L21	2,100	76
489-006-L35	3,500	114

Exclusive for fans with UL at the end of the model number.

(Products compliant with Electrical Appliance and Material Safety Law)
Model : 489-037-L10/489-037-L21/489-037-L35

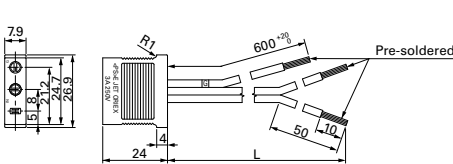

(UL/CSA CERTIFIED)

UL FILE No.E50197 CSA FILE No.LR67048
Model : 489-007-L10/489-007-L21

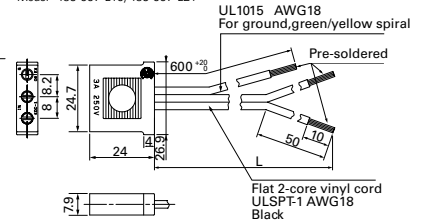

Model	Power cord length (L) [mm]	Mass [g]
489-037-L10	1,000	46
489-037-L21	2,100	76
489-037-L35	3,500	114
489-007-L10	1,000	48
489-007-L21	2,100	80

Airflow - Static Pressure Characteristics

Standard

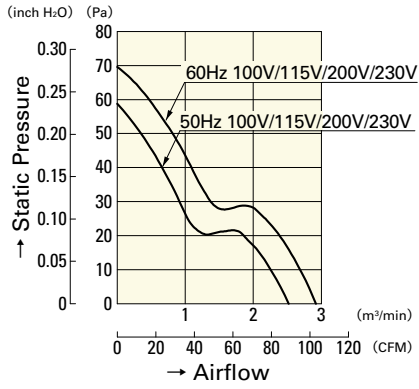

109S075UL **109S074UL**
109S078UL **109S072UL**

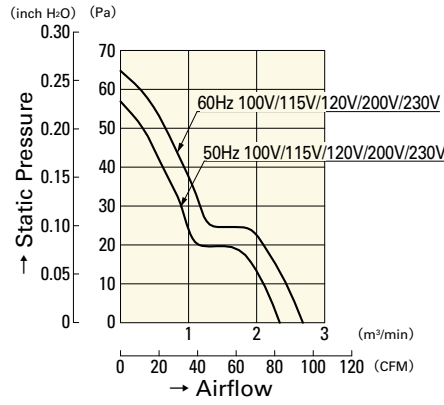

109S005 **109S005UL**
109S024 **109S024UL**
109S008 **109S008UL**
109S025 **109S025UL**

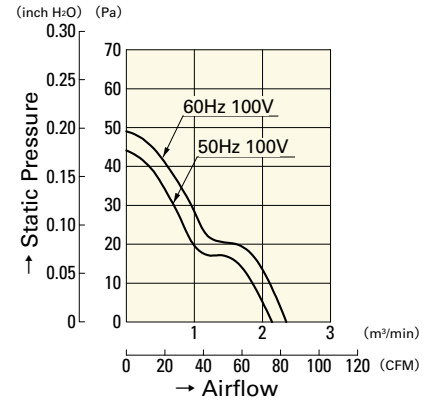

109S029UL

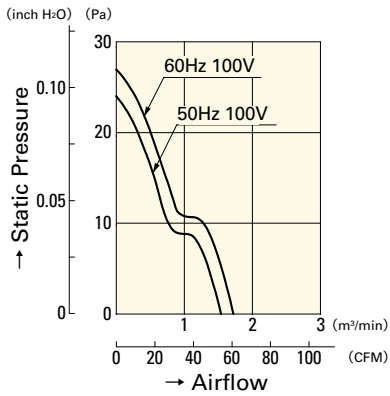

109S013
109S013UL

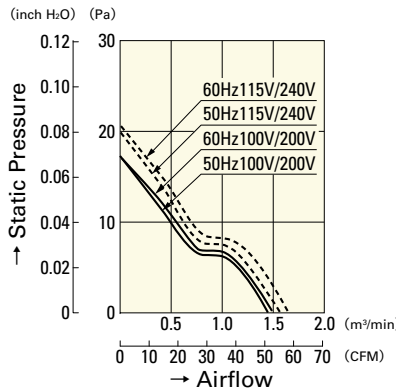

109S006 **109S006UL**
109S010 **109S010UL**

with Sensor

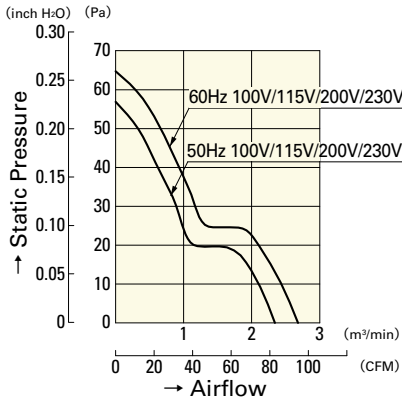

109S405UL **109S424UL**
109S408UL **109S425UL**

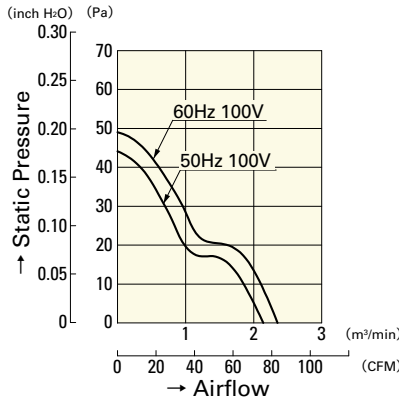

109S429UL

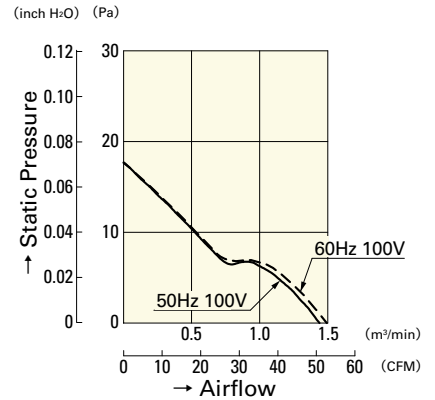

109S406UL

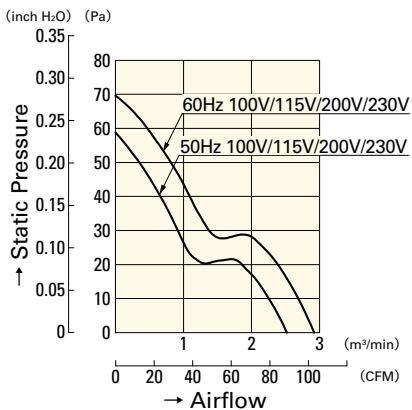

109S475UL **109S474UL**
109S478UL **109S472UL**

160 mm sq.

San Ace160



Only standard fans (without sensors) have acquired CSA certification.

General Specifications

- Material..... Frame: Aluminum, Impeller: Plastics (Flammability: UL94V-1)
- Expected Life Refer to specifications (L10:Survival rate: 90% at 60°C , rated voltage,and continuously run in a free air state)
- Dielectric Strength 50/60Hz 1,500VAC 1minute (between input terminal and frame)
- Dielectric Strength (With Sensor) ... Between AC input and DC input(Sensor output) : 50/60Hz 1,000VAC 1minute
Between AC input and G : 50/60Hz 1,500VAC 1minute,
Between G and DC input(Sensor output) : 50/60Hz 1,000VAC 1minute
- Sensor-Purpose Lead Wire ... ⊕ brown ⊖ black (Sensor) yellow
- Storage Temperature -30°C to +70°C (Non-condensing)
- Operating Voltage Range ... Voltage of each model ±10%

160×160×51mm (Mass : 1,100g)

Specifications Standard

Model No.	Rated Voltage [V]	Frequency [Hz]	Input [W]	Current [A]	Locked Rotor Current [A]	Rated Speed [min ⁻¹]	Max. Airflow [m ³ /min] [CFM]	Max. Static Pressure [Pa] [inchH ₂ O]	SPL [dB(A)]	Operating Temperature Range [°C]	Expected Life [h]
109-601	100	50/60	37.5/33	0.43/0.35	0.72/0.70	2,850/3,350	7.2/8.5 254.4/300.4	156.8/166.6 0.630/0.669	56/60	-30 to +60	25,000/60°C
109-604	115			0.39/0.31	0.62/0.61						
109-602	200			0.23/0.18	0.36/0.35						
109-603	230			0.21/0.16	0.32/0.31						

with Sensor

Model No.	Rated Voltage [V]	Frequency [Hz]	Input [W]	Current [A]	Locked Rotor Current [A]	Rated Speed [min ⁻¹]	Max. Airflow [m ³ /min] [CFM]	Max. Static Pressure [Pa] [inchH ₂ O]	SPL [dB(A)]	Operating Temperature Range [°C]	Expected Life [h]
109-641	100	50/60	37.5/33	0.43/0.35	0.72/0.70	2,850/3,350	7.2/8.5 254.4/300.4	156.8/166.6 0.630/0.669	56/60	-10 to +60	25,000/60°C
109-644	115			0.39/0.31	0.62/0.61						
109-642	200			0.23/0.18	0.36/0.35						
109-643	230			0.21/0.16	0.32/0.31						

Two types of power supplies, 5V (ITEM-20) and 12V (ITEM-30), are available in fans with sensor attached.

Set Models Fan, finger guard, plug cord, screws, etc. can be purchased in one package. For details, please refer to pp. 453 to 456.

Dimensions (unit: mm)

Standard

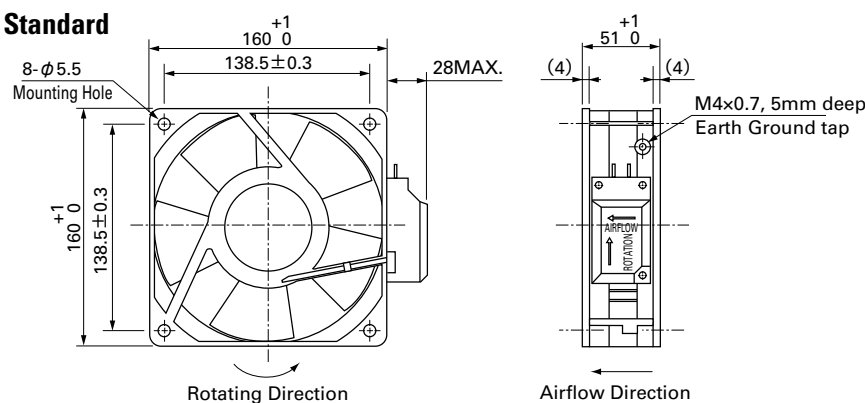

Reference Dimensions of Mounting Holes and Vent Opening (unit: mm)

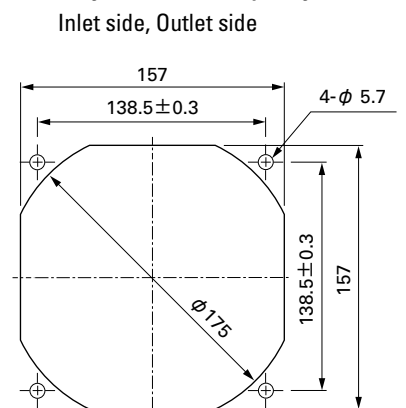

with Sensor

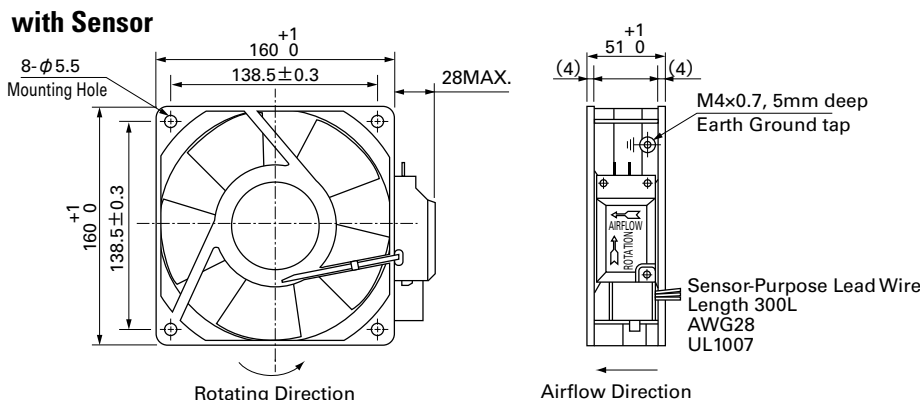

Wiring Diagram

Standard

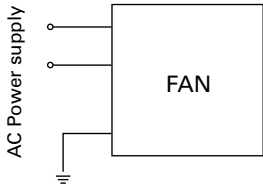

with Sensor (For fan power supply)

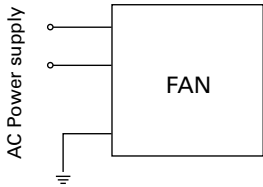

5V (ITEM-20)

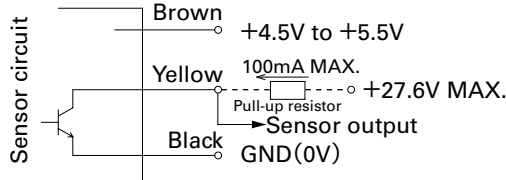

12V (ITEM-30)

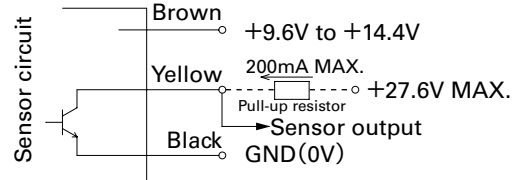

GND (Black) should be shared in case that power supply for sensor circuit (Brown) and that for sensor pull-up (Yellow) are separated.

Options (unit: mm)

Finger Guards

Model : 109-619E Surface treatment : Nickel-chrome plating (silver)
 : 109-619H : Cation electropainting (black)

Inlet side, Outlet side

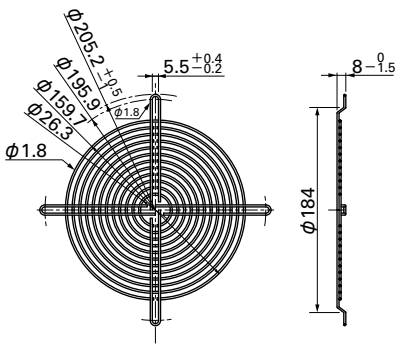

Mass : 85g

Model : 109-620 Surface treatment : Nickel-chrome plating (silver)
 Color : Cation electropainting (black)

Outlet side

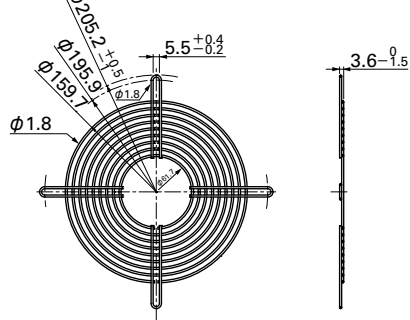

Mass : 74g

Plug Cord

(UL/CSA CERTIFIED)
 UL FILE No.E50197 CSA FILE No.LR67048
 Model : 489-084-L10/489-084-L21

Flat 2-core vinyl cord
 ULSP7-1
 AWG18 Black

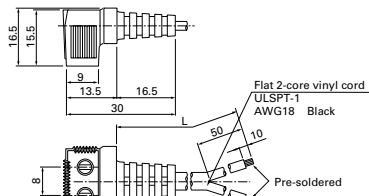

Model	Power cord length (L) [mm]	Mass [g]
489-084-L10	1,000	37
489-084-L21	2,100	70
489-086-L10	1,000	37
489-086-L21	2,100	70

(Products compliant with Electrical Appliance and Material Safety Law)
 Model : 489-1618-L10/489-1618-L21/489-1618-L28

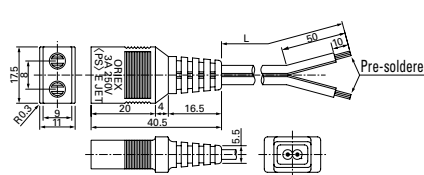

Model	Power cord length (L) [mm]	Mass [g]
489-1618-L10	1,000	34
489-1618-L21	2,100	63
489-1618-L28	2,800	83
489-1619-L10	1,000	34
489-1619-L21	2,100	64

(UL/CSA CERTIFIED)
 UL FILE No.E50197 CSA FILE No.LR67048
 Model : 489-086-L10/489-086-L21

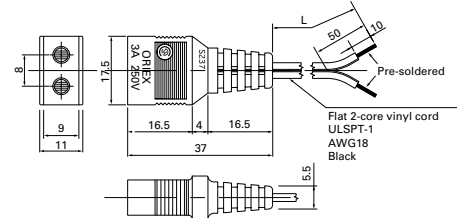

(Products compliant with Electrical Appliance and Material Safety Law)
 Model : 489-1619-L10/489-1619-L21

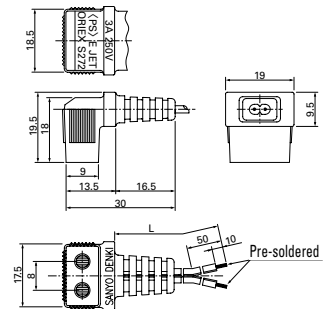

Airflow - Static Pressure Characteristics

Standard

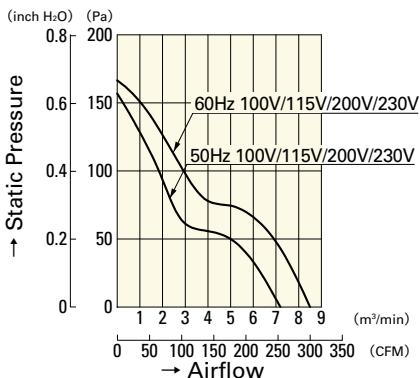

with Sensor

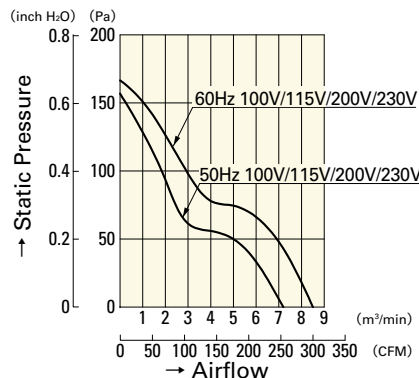

109-601 109-604

109-602 109-603

109-641 109-644

109-642 109-643

AC

AC Fan 160mm

φ172mm

San Ace 172



General Specifications

- Material Frame: Aluminum,
Impeller: Plastics (Flammability: UL94V-1)
- Expected Life Refer to specifications (L10:Survival rate: 90% at 60°C ,
rated voltage,and continuously run in a free air state)
- Dielectric Strength 50/60Hz 1,500VAC 1minute (between input terminal and frame)
- Storage Temperature -30°C to +70°C (Non-condensing)
- Operating Voltage Range ... Voltage of each model ±10%

φ172mm × 150mm × 51mm [Mass : 1,000g] **Sidecut type**

Specifications

Model No.	Rated Voltage [V]	Frequency [Hz]	Input [W]	Current [A]	Locked Rotor Current [A]	Rated Speed [min ⁻¹]	Max. Airflow [m ³ /min] [CFM]	Max. Static Pressure [Pa] [inchH ₂ O]	SPL [dB(A)]	Operating Temperature [°C]	Expected Life [h]
109S301	100	50/60	27/25	0.33/0.25	0.65/0.64	2,900/3,500	5.3/6.4 187.3/226.1	147/196 0.590/0.787	51/56	-30 to +60	25,000/60°C
109S304	115			0.29/0.22	0.55/0.54						
109S302	200			0.16/0.13	0.33/0.32						
109S303	230			0.14/0.11	0.28/0.27						

Set Models Fan, finger guard, plug cord, screws, etc. can be purchased in one package. For details, please refer to pp. 453 to 456.

Dimensions (unit: mm)

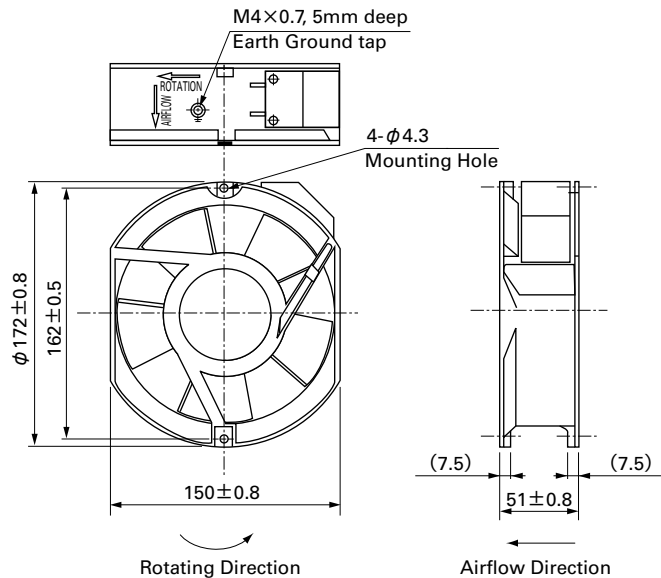

Reference Dimensions of Mounting Holes and Vent Opening (unit: mm)

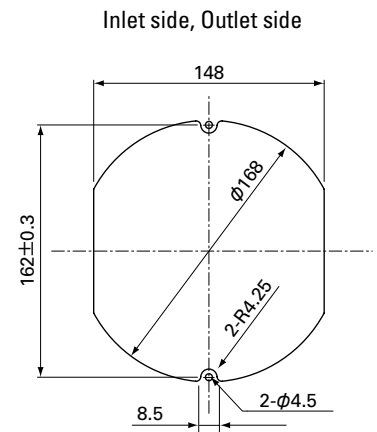

Wiring Diagram

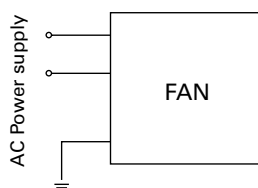

Options (unit: mm)

Finger Guards

Model : 109-319E Surface treatment : Nickel-chrome plating (silver) Color
 : 109-319H : Cation electropainting (black)

Inlet side, Outlet side

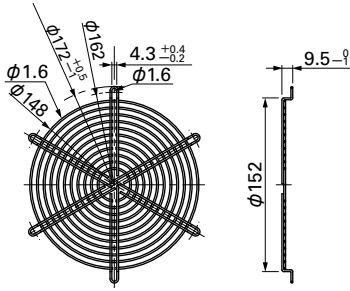

Mass : 69g

Outlet side

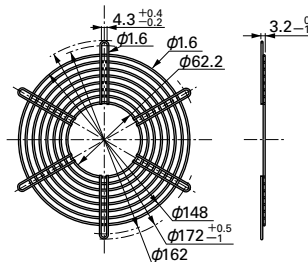

Mass : 53g

Plug Cord

(Products compliant with Electrical Appliance and Material Safety Law)
 Model : 489-1619-L10/489-1619-L21

(UL/CSA CERTIFIED)
 UL FILE No.E50197 CSA FILE No.LR67048
 Model : 489-084-L10/489-084-L21

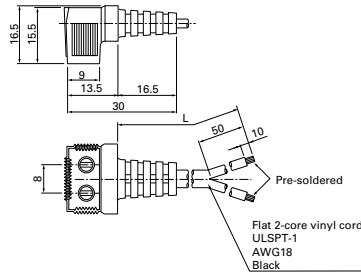
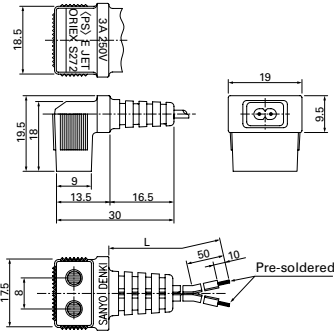

Model	Power cord length (L) [mm]	Mass [g]
489-1619-L10	1,000	34
489-1619-L21	2,100	64
489-084-L10	1,000	37
489-084-L21	2,100	70

Airflow - Static Pressure Characteristics

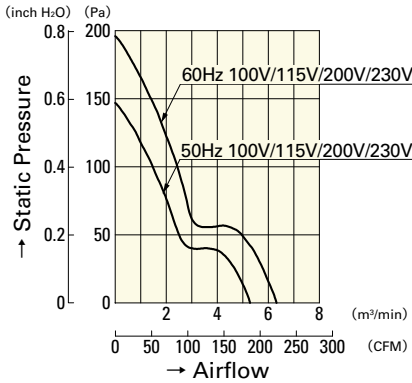

109S301	109S304
109S302	109S303

φ172mm

San Ace 172



General Specifications

- Material Frame: Aluminum,
Impeller: Plastics (Flammability: UL94V-1)
- Expected Life Refer to specifications (L10:Survival rate: 90% at 60°C ,
rated voltage, and continuously run in a free air state)
- Dielectric Strength 50/60Hz 1,500VAC 1minute (between input terminal and frame)
- Dielectric Strength (With Sensor) ... Between AC input and DC input(Sensor output)
: 50/60Hz 1,000VAC 1minute
Between AC input and G
: 50/60Hz 1,500VAC 1minute,
Between G and DC input(Sensor output)
: 50/60Hz 1,000VAC 1minute
- Sensor-Purpose Lead Wire ... ⊕ brown ⊖ black (Sensor) yellow
- Storage Temperature -30°C to +70°C (Non-condensing)
- Operating Voltage Range ... Voltage of each model ±10%

φ172mm×51mm (Mass : 1,000g) **Round type**

Specifications Standard

Model No.	Rated Voltage [V]	Frequency [Hz]	Input [W]	Current [A]	Locked Rotor Current [A]	Rated Speed [min ⁻¹]	Max. Airflow [m ³ /min] [CFM]	Max. Static Pressure [Pa] [inchHzO]	SPL [dB(A)]	Operating Temperature [°C]	Expected Life [h]
109-311	100	50/60	27/25	0.33/0.25	0.65/0.64	2,900/3,500	5.3/6.4 187.3/226.1	147/196 0.590/0.787	47/51	-30 to +60	25,000/60°C
109-314	115			0.29/0.22	0.55/0.54						
109-312	200			0.16/0.13	0.33/0.32						
109-313	230			0.14/0.11	0.28/0.27						

with Sensor

Model No.	Rated Voltage [V]	Frequency [Hz]	Input [W]	Current [A]	Locked Rotor Current [A]	Rated Speed [min ⁻¹]	Max. Airflow [m ³ /min] [CFM]	Max. Static Pressure [Pa] [inchHzO]	SPL [dB(A)]	Operating Temperature [°C]	Expected Life [h]
109-371	100	50/60	27/25	0.33/0.25	0.65/0.64	2,900/3,500	5.3/6.4 187.3/226.1	147/196 0.590/0.787	47/51	-10 to +60	25,000/60°C
109-374	115			0.29/0.22	0.55/0.54						
109-372	200			0.16/0.13	0.33/0.32						
109-373	230			0.14/0.11	0.28/0.27						

Two types of power supplies, 5V (ITEM-20) and 12V (ITEM-30), are available in fans with sensor attached.

Set Models Fan, finger guard, plug cord, screws, etc. can be purchased in one package.
For details, please refer to pp. 453 to 456.

Dimensions (unit: mm)

Standard

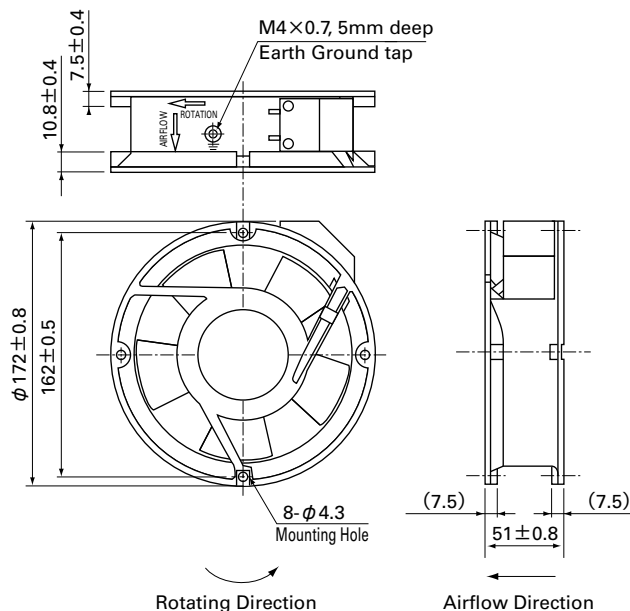

with Sensor

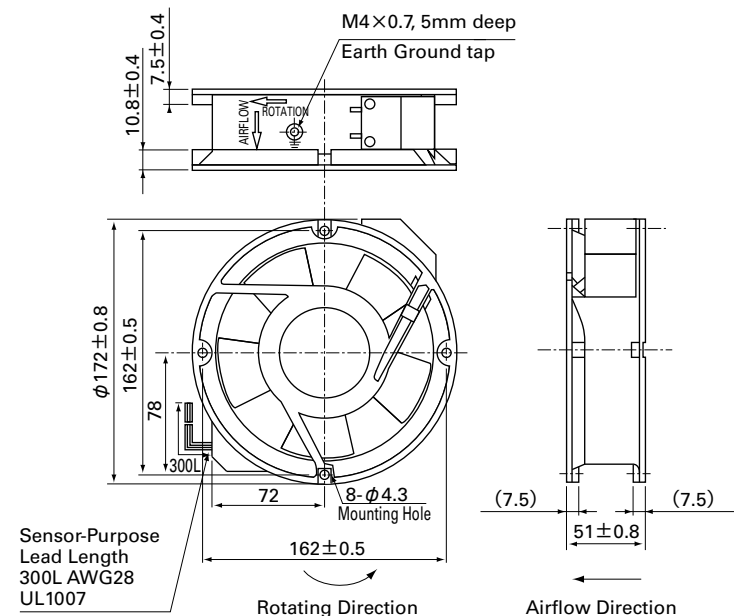

Reference Dimensions of Mounting Holes and Vent Opening (unit: mm)

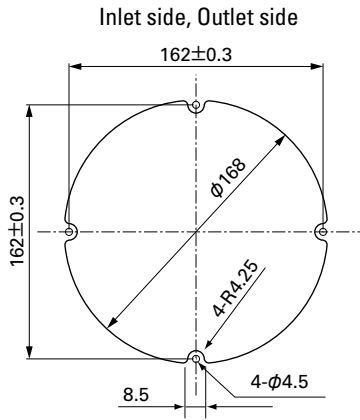

Wiring Diagram

Standard

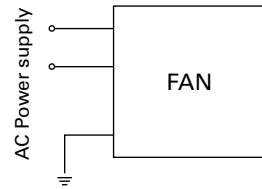

with Sensor

(For fan power supply)

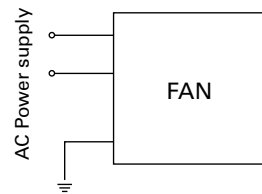

5V (ITEM-20)

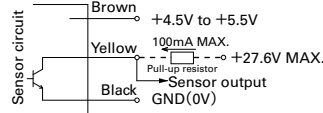

12V (ITEM-30)

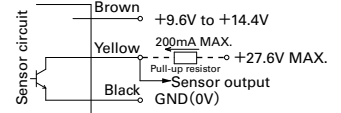

GND (Black) should be shared in case that power supply for sensor circuit (Brown) and that for sensor pull-up (Yellow) are separated.

Options (unit: mm)

Finger Guards

Model : 109-319E Surface treatment : Nickel-chrome plating (silver) Color : Nickel-chrome plating (silver)
 : 109-319H : Cation electropainting (black)

Inlet side, Outlet side

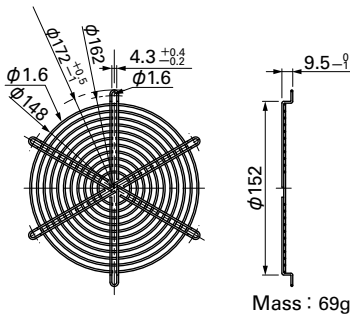

Model : 109-1066 Surface treatment : Nickel-chrome plating (silver) Color : Nickel-chrome plating (silver)

Inlet side, Outlet side

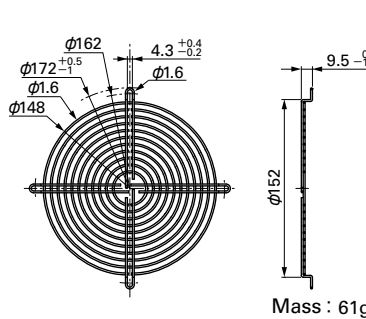

Model : 109-320 Surface treatment : Nickel-chrome plating (silver) Color : Nickel-chrome plating (silver)

Outlet side

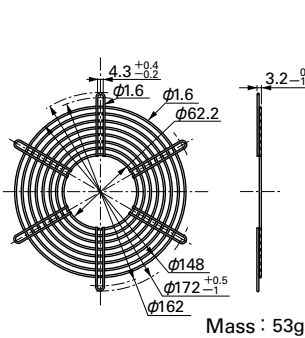

Model : 109-1068 Surface treatment : Nickel-chrome plating (silver) Color : Nickel-chrome plating (silver)

Outlet side

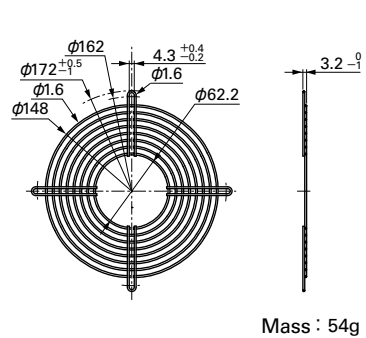

Plug Cord

(Products compliant with Electrical Appliance and Material Safety Law)
 Model : 489-1619-L10/489-1619-L21

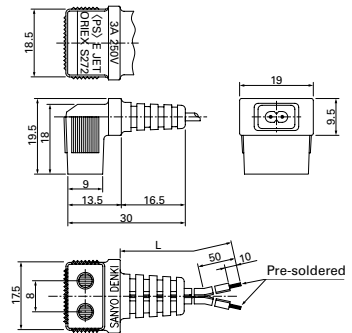

(UL/CSA CERTIFIED)
 UL FILE No. E50197 CSA FILE No. LR67048
 Model : 489-084-L10/489-084-L21

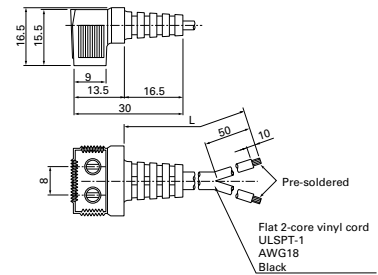

Model	Power cord length (L) [mm]	Mass [g]
489-1619-L10	1,000	34
489-1619-L21	2,100	64
489-084-L10	1,000	37
489-084-L21	2,100	70

Airflow - Static Pressure Characteristics

Standard

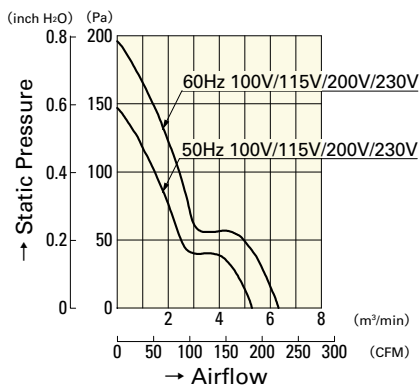

with Sensor

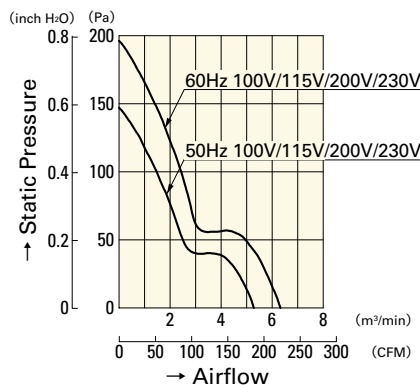

109-311 109-314
 109-312 109-313

109-371 109-374
 109-372 109-373

- Ideal fan sizes selected for various control panels, automated machines, and power supply units.
- You can purchase everything necessary in one order without the need for searching for the fan peripherals. It makes fan replacements easy.
- Delivered in one package, it simplifies storage and maintenance.

Set configuration items

Fan
+
Finger guards
+
Plug cord
+
Screws
(with flat washer and spring washer)
+
Hex nuts
+
Instruction manual



One order includes everything needed for operation.



*Package image

Plug cords are compliant with Electrical Appliance and Material Safety Law, but not UL/CSA certified.

■ Cooling Fan Set Models Line Up

Series	Fan size	Order no. (set model)	Set items					page		
			Fan	Voltage	Low-speed sensor	Plug cord	Finger guards		Mounting screws	
AC fan	60 × 60 × 28mm	ST1-109-180	109-180	100V		Plug cord is not included because of the exposed-lead structure.	109-139E	M4 × 40mm (4 screws)	p. 423	
		ST1-109-183	109-183	115V			109-139E			
	60 × 60 × 38mm	ST1-109-130	109-130	100V			109-139E	M4 × 55mm (4 screws)	p. 425	
		ST1-109-133	109-133	115V			109-139E			
	80 × 80 × 20mm	ST1-109-210	109-210	100V			109-049E	M4 × 40mm (4 screws)	p. 427	
		ST1-109-213	109-213	115V			109-049E			
	80 × 80 × 25mm	ST1-109S050	109S050	100V			489-016-L10	109-049E	M4 × 40mm (4 screws) *	p. 429
		ST1-109S053	109S053	115V			489-016-L10	109-049E		
		ST1-109S051	109S051	200V			489-016-L10	109-049E		
		ST1-109S054	109S054	230V			489-016-L10	109-049E		
		ST1-109S030	109S030	100V			489-016-L10	109-049E		
		ST1-109S033	109S033	115V			489-016-L10	109-049E		
		ST1-109S031	109S031	200V			489-016-L10	109-049E		
	80 × 80 × 38mm	ST1-109-150	109-150	100V			489-016-L10	109-049E	M4 × 55mm (4 screws) *	p. 431
		ST1-109-153	109-153	115V			489-016-L10	109-049E		
		ST1-109-151	109-151	200V			489-016-L10	109-049E		
		ST1-109-154	109-154	230V			489-016-L10	109-049E		
	80 × 80 × 42mm	ST1-109-040UL	109-040UL	100V			489-008-L10	109-049E	M4 × 55mm (4 screws)	p. 433
		ST1-109-043UL	109-043UL	115V			489-008-L10	109-049E		
		ST1-109-041UL	109-041UL	200V			489-008-L10	109-049E		
		ST1-109-044UL	109-044UL	230V			489-008-L10	109-049E		
		ST1-109-047UL	109-047UL	100V			489-008-L10	109-049E		
	92 × 92 × 25mm	ST1-109S091	109S091	100V			489-016-L10	109-099E	M3 × 40mm (4 screws) *	p. 435
		ST1-109S093	109S093	115V			489-016-L10	109-099E		
		ST1-109S092	109S092	200V			489-016-L10	109-099E		
		ST1-109S094	109S094	230V			489-016-L10	109-099E		
		ST1-109S095	109S095	100V			489-016-L10	109-099E		
		ST1-109S096	109S096	100V			489-016-L10	109-099E		
		ST1-109S193	109S193	115V			489-016-L10	109-099E		
		ST1-109S192	109S192	200V			489-016-L10	109-099E		
		ST1-109S194	109S194	230V			489-016-L10	109-099E		
		ST1-109S491-20	109S491-20	100V		○ (5V)	489-016-L10	109-099E		
		ST1-109S491-30	109S491-30			○ (12V)	489-016-L10	109-099E		
		ST1-109S493-20	109S493-20	115V		○ (5V)	489-016-L10	109-099E		
		ST1-109S493-30	109S493-30			○ (12V)	489-016-L10	109-099E		
		ST1-109S492-20	109S492-20	200V		○ (5V)	489-016-L10	109-099E		
		ST1-109S492-30	109S492-30			○ (12V)	489-016-L10	109-099E		
		ST1-109S494-20	109S494-20	230V		○ (5V)	489-016-L10	109-099E		
		ST1-109S494-30	109S494-30			○ (12V)	489-016-L10	109-099E		
		ST1-109S495-20	109S495-20	100V		○ (5V)	489-016-L10	109-099E		
		ST1-109S495-30	109S495-30			○ (12V)	489-016-L10	109-099E		
		ST1-109S496-20	109S496-20			○ (5V)	489-016-L10	109-099E		
	ST1-109S496-30	109S496-30			○ (12V)	489-016-L10	109-099E			
	ACDC fan (Low Power Consumption, Long Life)	92 × 92 × 38mm	ST1-9AD0901H12	9AD0901H12	100 to 240V		489-1635-L10	109-099E	M4 × 55mm (4 screws)	p. 413
			ST1-9AD0901M12	9AD0901M12			489-1635-L10	109-099E		
			ST1-9AD0901H1H	9AD0901H1H		○	489-1635-L10	109-099E		
			ST1-9AD0901M1H	9AD0901M1H		○	489-1635-L10	109-099E		
AC fan	120 × 120 × 25mm	ST1-109S085	109S085	100V		489-016-L10	109-019E	M3 × 40mm (4 screws)	p. 439	
		ST1-109S084	109S084	115V		489-016-L10	109-019E			
		ST1-109S088	109S088	200V		489-016-L10	109-019E			
		ST1-109S087	109S087	230V		489-016-L10	109-019E			
		ST1-109S081	109S081	100V		489-016-L10	109-019E			
		ST1-109S083	109S083	115V		489-016-L10	109-019E			
		ST1-109S082	109S082	200V		489-016-L10	109-019E			
		ST1-109S089	109S089	230V		489-016-L10	109-019E			
		ST1-109S086	109S086			489-016-L10	109-019E			
		ST1-109S485-20	109S485-20	100V		○ (5V)	489-016-L10			109-019E
		ST1-109S485-30	109S485-30			○ (12V)	489-016-L10			109-019E

* Though these are 2-hole or 3-hole frame mount types, 4 screws are included for extra.

Sale Notice of Cooling Fan Set Models

Series	Fan size	Order no. (set model)	Set items						page				
			Fan	Voltage	Low-speed sensor	Plug cord	Finger guards	Mounting screws					
AC fan	120×120×25mm	ST1-109S484-20	109S484-20	115V	○ (5V)	489-016-L10	109-019E	M3×40mm (4 screws)	p. 439				
		ST1-109S484-30	109S484-30		○ (12V)	489-016-L10	109-019E						
		ST1-109S488-20	109S488-20	200V	○ (5V)	489-016-L10	109-019E						
		ST1-109S488-30	109S488-30		○ (12V)	489-016-L10	109-019E						
		ST1-109S487-20	109S487-20	230V	○ (5V)	489-016-L10	109-019E						
		ST1-109S487-30	109S487-30		○ (12V)	489-016-L10	109-019E						
		ST1-109S486-20	109S486-20	100V	○ (5V)	489-016-L10	109-019E						
		ST1-109S486-30	109S486-30		○ (12V)	489-016-L10	109-019E						
ACDC fan (Low Power Consumption, Long Life)	120×120×38mm	ST1-9AD1201H12	9AD1201H12	100 to 240V		489-1635-L10	109-019E	M4×55mm (4 screws)	p. 417				
		ST1-9AD1201H1H	9AD1201H1H		○	489-1635-L10	109-019E						
AC fan	120×120×38mm	ST1-109S075UL	109S075UL	100V		489-037-L10	109-019E	M3×55mm (4 screws)	p. 443				
		ST1-109S074UL	109S074UL	115V		489-037-L10	109-019E						
		ST1-109S078UL	109S078UL	200V		489-037-L10	109-019E						
		ST1-109S072UL	109S072UL	230V		489-037-L10	109-019E						
		ST1-109S005	109S005	100V		489-006-L10	109-019E						
		ST1-109S005UL	109S005UL		489-037-L10	109-019E							
		ST1-109S024	109S024	120V		489-006-L10	109-019E						
		ST1-109S024UL	109S024UL	115V		489-037-L10	109-019E						
		ST1-109S008	109S008	200V		489-006-L10	109-019E						
		ST1-109S008UL	109S008UL		489-037-L10	109-019E							
		ST1-109S025	109S025	230V		489-006-L10	109-019E						
		ST1-109S025UL	109S025UL		489-037-L10	109-019E							
		ST1-109S029UL	109S029UL	100V		489-037-L10	109-019E						
		ST1-109S013	109S013		489-006-L10	109-019E							
		ST1-109S013UL	109S013UL		489-037-L10	109-019E							
		ST1-109S006	109S006		489-006-L10	109-019E							
		ST1-109S006UL	109S006UL	100V 115V		489-037-L10	109-019E						
		ST1-109S010	109S010	200V		489-006-L10	109-019E						
		ST1-109S010UL	109S010UL	200V 240V		489-037-L10	109-019E						
		ST1-109S405UL-20	109S405UL-20	100V	○ (5V)	489-037-L10	109-019E						
		ST1-109S405UL-30	109S405UL-30		○ (12V)	489-037-L10	109-019E						
		ST1-109S424UL-20	109S424UL-20	115V	○ (5V)	489-037-L10	109-019E						
		ST1-109S424UL-30	109S424UL-30		○ (12V)	489-037-L10	109-019E						
		ST1-109S408UL-20	109S408UL-20	200V	○ (5V)	489-037-L10	109-019E						
		ST1-109S408UL-30	109S408UL-30		○ (12V)	489-037-L10	109-019E						
		ST1-109S425UL-20	109S425UL-20	230V	○ (5V)	489-037-L10	109-019E						
		ST1-109S425UL-30	109S425UL-30		○ (12V)	489-037-L10	109-019E						
		ST1-109S429UL-20	109S429UL-20	100V	○ (5V)	489-037-L10	109-019E						
		ST1-109S429UL-30	109S429UL-30		○ (12V)	489-037-L10	109-019E						
		ST1-109S406UL-20	109S406UL-20	100V	○ (5V)	489-037-L10	109-019E						
		ST1-109S406UL-30	109S406UL-30		○ (12V)	489-037-L10	109-019E						
		ST1-109S475UL-20	109S475UL-20	100V	○ (5V)	489-037-L10	109-019E						
		ST1-109S475UL-30	109S475UL-30		○ (12V)	489-037-L10	109-019E						
		ST1-109S474UL-20	109S474UL-20	115V	○ (5V)	489-037-L10	109-019E						
		ST1-109S474UL-30	109S474UL-30		○ (12V)	489-037-L10	109-019E						
		ST1-109S478UL-20	109S478UL-20	200V	○ (5V)	489-037-L10	109-019E						
		ST1-109S478UL-30	109S478UL-30		○ (12V)	489-037-L10	109-019E						
		ST1-109S472UL-20	109S472UL-20	230V	○ (5V)	489-037-L10	109-019E						
		ST1-109S472UL-30	109S472UL-30		○ (12V)	489-037-L10	109-019E						
			160×160×51mm	ST1-109-601	109-601	100V				489-1618-L10	109-619E	M5×20mm (4 screws)	p. 447
				ST1-109-604	109-604	115V				489-1618-L10	109-619E		
				ST1-109-602	109-602	200V				489-1618-L10	109-619E		
				ST1-109-603	109-603	230V				489-1618-L10	109-619E		
ST1-109-641-20	109-641-20			100V	○ (5V)	489-1618-L10	109-619E						
ST1-109-641-30	109-641-30				○ (12V)	489-1618-L10	109-619E						
ST1-109-644-20	109-644-20			115V	○ (5V)	489-1618-L10	109-619E						
ST1-109-644-30	109-644-30				○ (12V)	489-1618-L10	109-619E						
ST1-109-642-20	109-642-20			200V	○ (5V)	489-1618-L10	109-619E						
ST1-109-642-30	109-642-30				○ (12V)	489-1618-L10	109-619E						

Series	Fan size	Order no. (set model)	Set items						page	
			Fan	Voltage	Low-speed sensor	Plug cord	Finger guards	Mounting screws		
AC fan	160×160×51mm	ST1-109-643-20	109-643-20	230V	○ (5V)	489-1618-L10	109-619E	M5×20mm (4 screws)	p. 447	
		ST1-109-643-30	109-643-30		○ (12V)	489-1618-L10	109-619E			
	φ 172×150×51mm	ST1-109S301	109S301	100V			489-1619-L10	109-319E	M4×25mm (4 screws) ※	p. 449
		ST1-109S304	109S304	115V			489-1619-L10	109-319E		
		ST1-109S302	109S302	200V			489-1619-L10	109-319E		
		ST1-109S303	109S303	230V			489-1619-L10	109-319E		
	φ 172×51mm	ST1-109-311	109-311	100V			489-1619-L10	109-319E	M4×25mm (4 screws)	p. 451
		ST1-109-314	109-314	115V			489-1619-L10	109-319E		
		ST1-109-312	109-312	200V			489-1619-L10	109-319E		
		ST1-109-313	109-313	230V			489-1619-L10	109-319E		
		ST1-109-371-20	109-371-20	100V		○ (5V)	489-1619-L10	109-319E		
		ST1-109-371-30	109-371-30			○ (12V)	489-1619-L10	109-319E		
		ST1-109-374-20	109-374-20	115V		○ (5V)	489-1619-L10	109-319E		
		ST1-109-374-30	109-374-30			○ (12V)	489-1619-L10	109-319E		
		ST1-109-372-20	109-372-20	200V		○ (5V)	489-1619-L10	109-319E		
		ST1-109-372-30	109-372-30			○ (12V)	489-1619-L10	109-319E		
		ST1-109-373-20	109-373-20	230V		○ (5V)	489-1619-L10	109-319E		
		ST1-109-373-30	109-373-30			○ (12V)	489-1619-L10	109-319E		

※ Though these are 2-hole or 3-hole frame mount types, 4 screws are included for extra.

PWM Controller

Features

Reduces system power consumption and fan noise

For PWM fan speed control, a PWM control circuit needs to be newly designed and configured.

By using this product, however, PWM control function fans can be fully utilized without the need for preparing new circuits, contributing to reducing the system power consumption and the fan noise.

Can be common-powered by the fan power supply

The controller can be powered by the fan power supply of rated voltage 12, 24, and 48 VDC, and no separate supply is required.

Maximum of four fans connectable

Up to four fans with PWM control function can be connected and controlled.

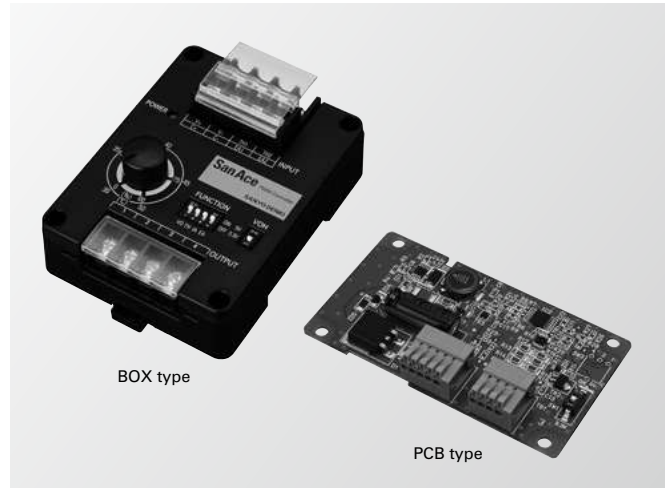

Specifications

	BOX type	PCB type		
Model no.	9PC8666X-S001	9PC8045D-V001	9PC8045D-R001	9PC8045D-T001
Size [mm]	86 (H) × 66 (W) × 38 (D)	80 (H) × 45 (W) × 17 (D)		
Rated voltage [V]	12 / 24 / 48			
Power consumption [W]	0.2*1			
Operating temperature [°C]	-20 to +70			
Input terminal	Input voltage range [V] (V+, V-)	7 to 60		
	Control voltage range [V]	0 to 5.5		
Output terminal	PWM signal output	V _{OH} (high level voltage): 3.3 or 5 VDC selectable		
	PWM frequency [kHz]	25		
	Output current	20 mA max. (total sum of 4 terminals)		
	Output breakdown voltage [V]	6.5		
	No. of connectable fans	Up to 4 fans		
Control functions*2	Voltage control, Internal adjustment (variable resistor) control, External adjustment (variable resistor) control*3, Thermistor control*3	Voltage control	Variable resistor control*3	Thermistor control*3
Mounting method	DIN rail mounting or screw mounting	Screw mounting		
Mass [g]	110	27		
Material	Case: Plastics	PCB: FR-4		

*1: When output terminals are turned on. *2: Control functions are mutually exclusive for BOX type.

*3: Variable resistor and thermistor are not supplied with the controller and need to be prepared separately.

Be noted that if applied input voltage or frequency is out of range of the connected fan, how the fan speed responds to the PWM duty cycle may be altered.

Front View (component names)

• BOX type

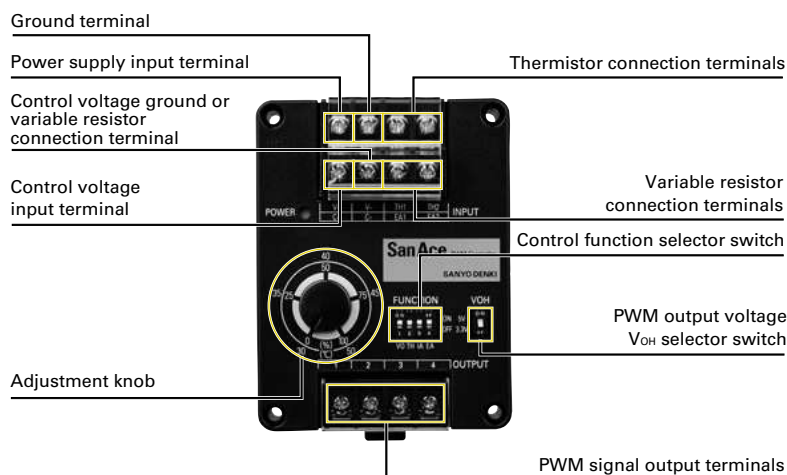

• PCB type

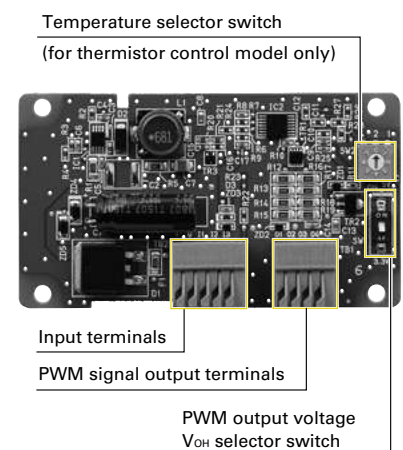

■ Connection Examples and PWM Signal Output Characteristics

Controller can be common-powered by the power supply for 12, 24, and 48 VDC rated voltage fans. It can also be powered by a separate supply as long as both supplies share the same ground.

Voltage control

Output duty cycle controlled with input voltage of 0 to 5 VDC. *Ensure that the input voltage does not exceed 5.5 VDC.

- BOX type

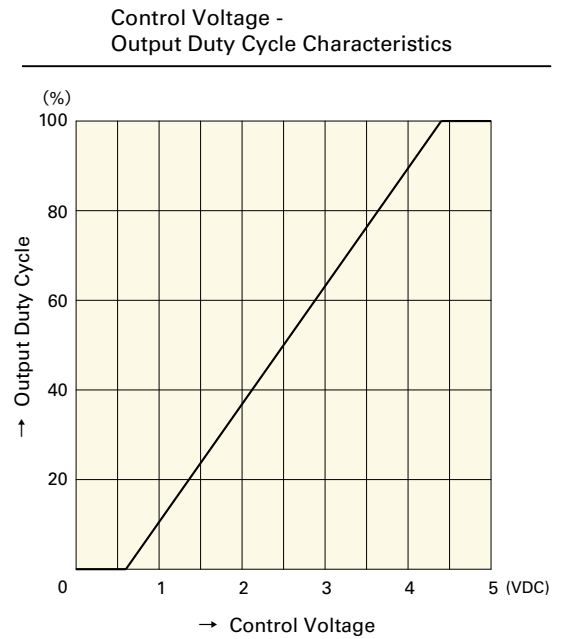
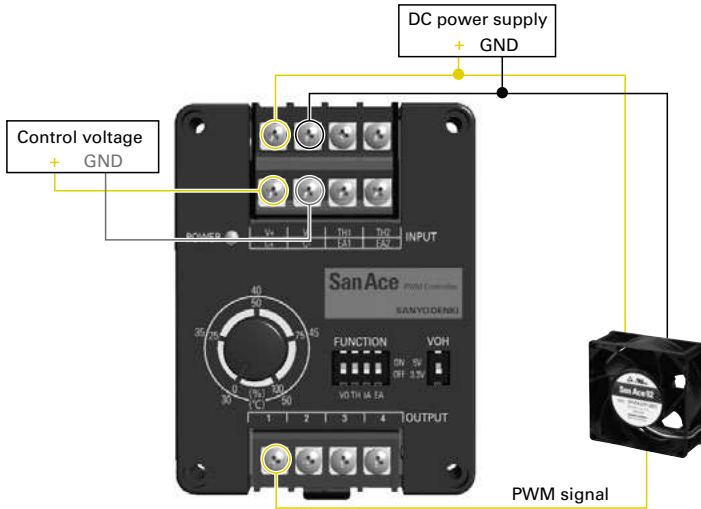

- PCB type (Model no.: 9PC8045D-V001)

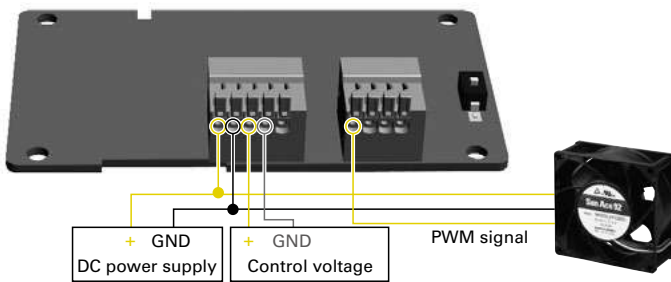

Internal adjustment (variable resistor) control

Output duty cycle controlled with the adjustment knob.

- BOX type

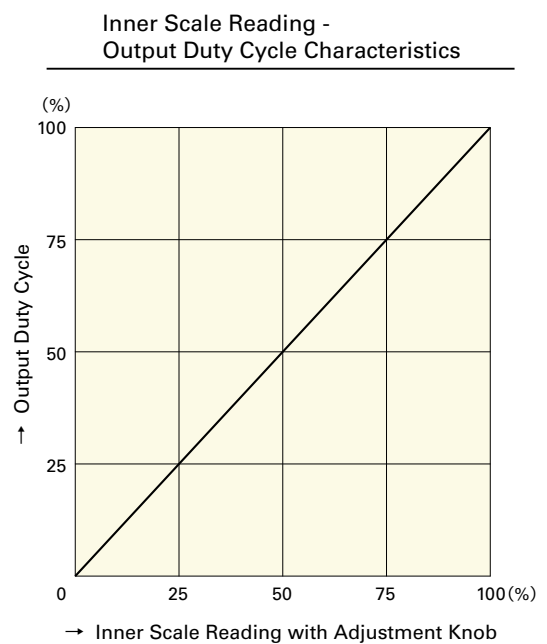
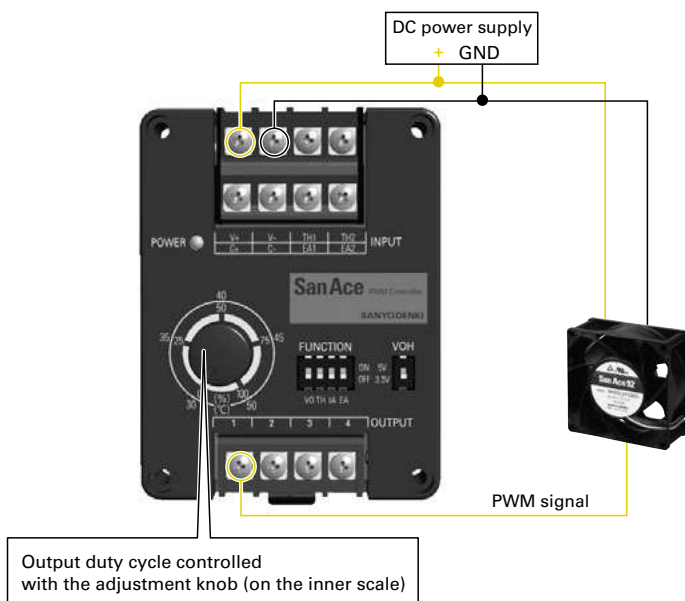

PWM Controller

External adjustment (variable resistor) control

Output duty cycle controlled with variable resistor connected to terminals.

- BOX type

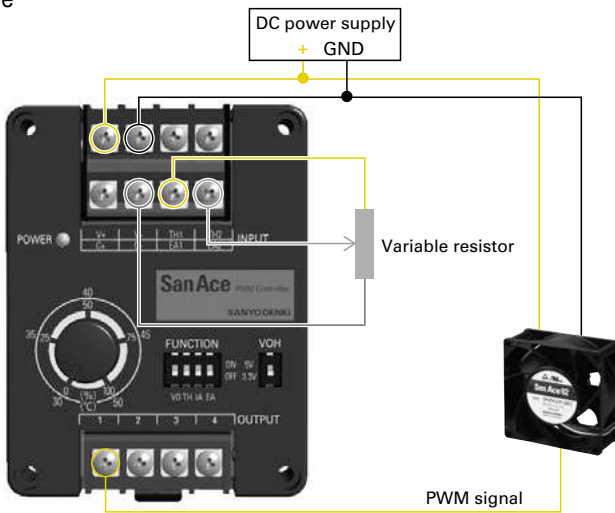

Resistance - Output Duty Cycle Characteristics

Recommended total resistance: 10 kΩ
Resistance increment characteristics: B (linear curve fitting)

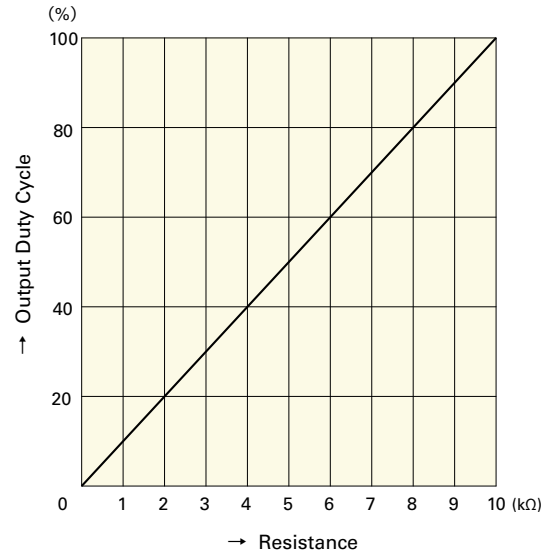

- PCB type (Model no.: 9PC8045D-R001)

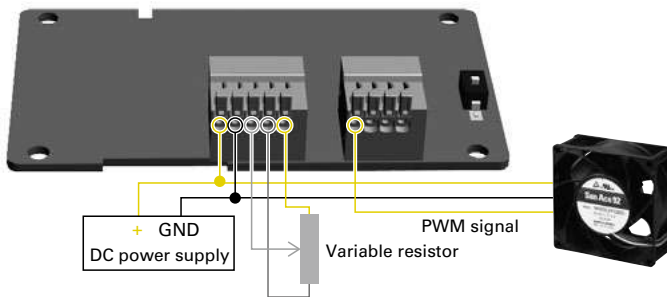

Thermistor control

Automation control of output duty cycle in response to the temperature detected with an external thermistor.

- BOX type

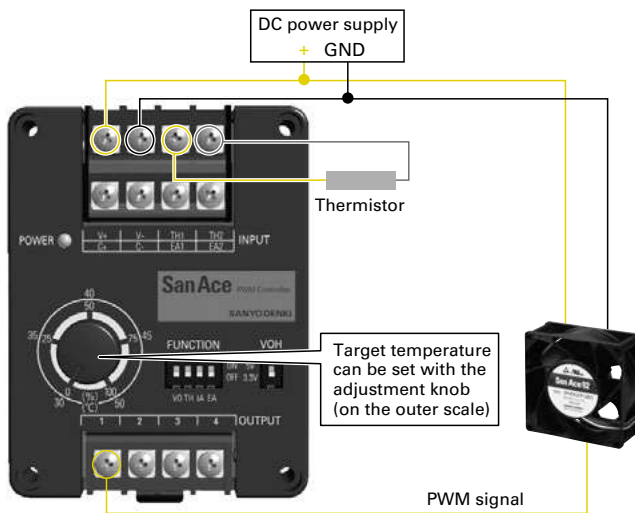

Controlling Conditions

T_{ST} : Temperature set with the adjustment knob (30 to 50 °C)
 T_{TH} : Temperature detected with thermistor

Recommended thermistor conditions

Type: NTC

R_{25} (Resistance at 25 °C): 10 kΩ

B value: $B_{25/85} = 3435$ K

Temperature conditions	Duty cycle	Fan rotational speed (For reference)
$T_{ST} < T_{TH}$	Increases	Increases
$T_{ST} > T_{TH}$	Decreases	Decreases
$T_{ST} \approx T_{TH}$	Maintained	Maintained

- PCB type (Model no.: 9PC8045D-T001)

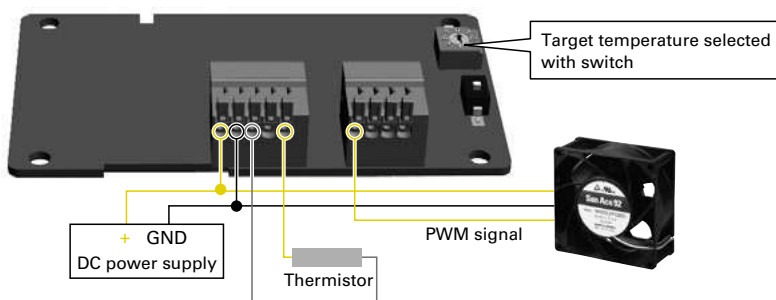

■ Dimensions (unit: mm)

● BOX type

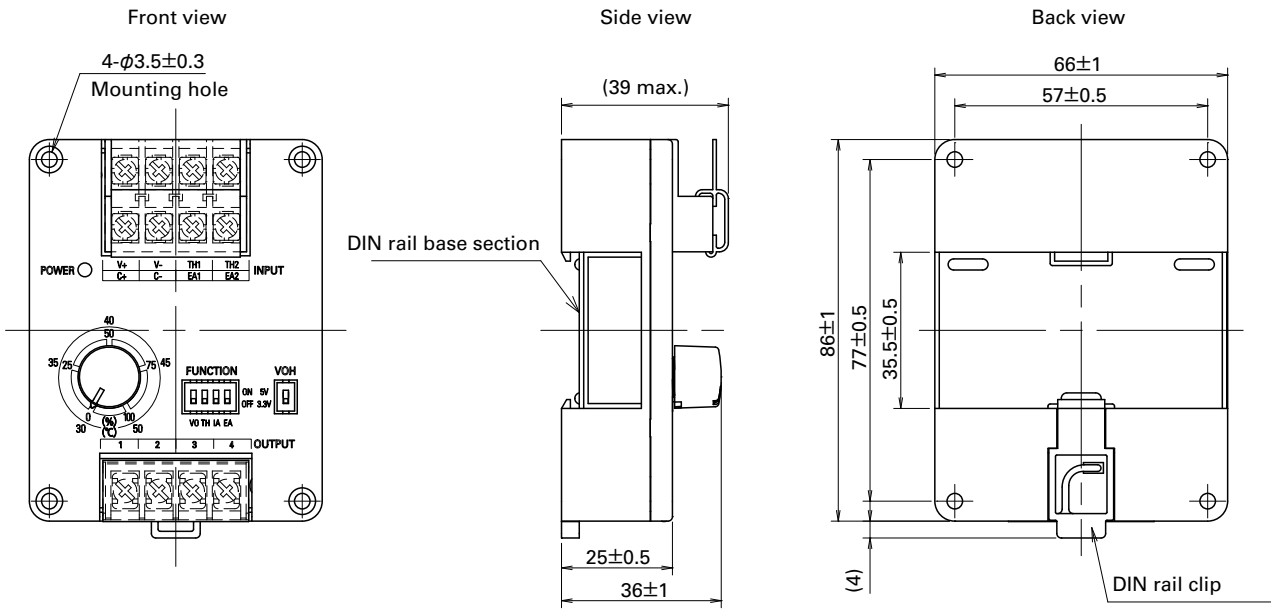

● PCB type

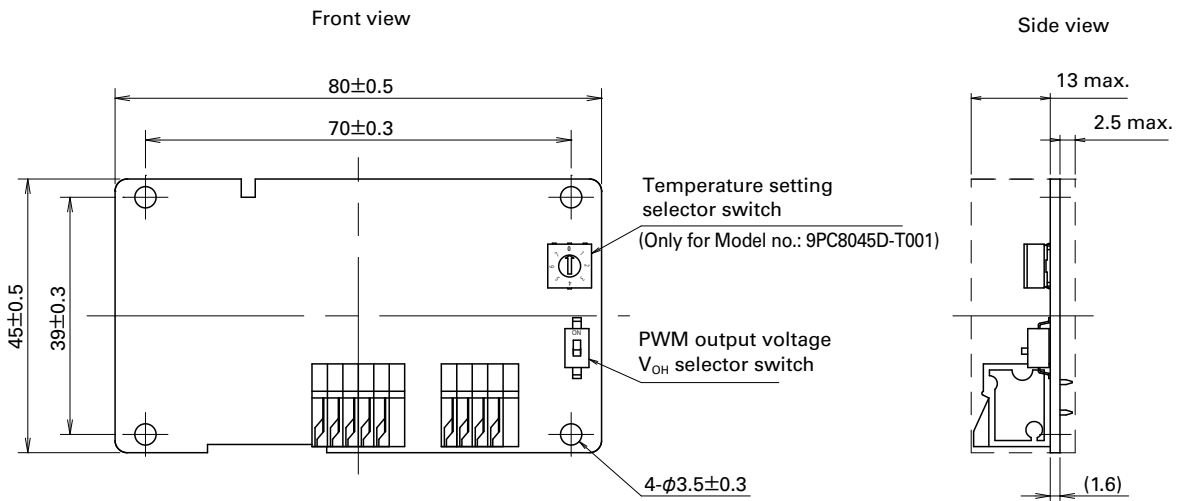



Safety Precautions

BOX type

- To ensure that the product is used safely, be sure to read and fully understand the Safety Precautions and only use the product as directed.
- Read the Safety Precautions carefully before installing, connecting, operating, maintaining, or inspecting the product.
- The product has been designed and manufactured for use in general industrial machinery, and may not be used as a standalone product.
- The product of our company (hereafter referred to as "the product") falls into the category of the products specified in the Attached List 1, Item 16 (Class 85, Item 43) of the Export Trade Control Ordinance. To export the product as an individual part or to export a device into which the product is assembled, the "Information Requirements" and "Objective Requirements" that the Ministry of Economy, Trade and Industry established based on the "Catchall Controls" must be studied for applicability. Based on information on applicability and specified requirements, appropriate export procedures must be taken.
- When disposing of the product, treat it as industrial waste. For instructions on proper disposal methods, please contact local government authorities.
- When using the product in an environment with vibration, such as in a car or a ship, use it at your own discretion only after deploying sufficient safety measures and making prior evaluations. Fully understand the Safety Precautions described in this instruction manual before using the product.

In order to prevent any possible bodily injury or damage to property or equipment, the following precautions for ensuring safety are displayed according to the following two ranks of importance:

 Danger	Handling or using the product improperly and in disregard of the instructions with this mark may result in serious bodily injury or death.
 Caution	Handling or using the product improperly and in disregard of the instructions with this mark may result in bodily injury or physical damage.

*Note: Items marked 'Caution' may also result in serious bodily injury or death in some circumstances. Always follow the instructions for items marked 'Danger.'

Danger

- If the product is used in medical appliances or other types of equipment that affect people's lives, sufficient safety-related evaluations and preparations must be made in advance, and the product or the type of equipment into which the product is assembled must be used under the full responsibility of the user.
- If the product is used in types of equipment that have a strong social and public impact, sufficient prior evaluations and safety-related evaluations and preparations must be made, and the product or the type of equipment into which the product is assembled must be used under the full responsibility of the user.
- The product is not designed to be used in a car or a ship. When using the product in an environment with vibration, such as in a car or a ship, use it at your own discretion only after deploying sufficient safety measures and making prior evaluations.
- Connect all wires properly and securely. Failure to do so may result in fire, burns, or electrical shock.
- Do not use the product in a location where there is flammable gas. Otherwise, it may result in fire, burns, or bodily injury.
- Do not operate the product when electronic components are exposed. Otherwise, it may result in electrical shock.
- Turn off the power and stop using the product immediately if you notice any sparks, smoke, odd odors, sounds, or anything unusual during operation. Failure to do so may result in fire, bodily injury, or electrical shock.
- Never allow the product to fall, topple over, or otherwise be subjected to excessive shocks when moving it. Otherwise, it may result in product failure.
- The product should be handled only by personnel with sufficient training and knowledge and under the full responsibility of the user.
- Never attempt to disassemble, repair, or alter the product in any way, as doing so may result in fire, burns, or electrical shock.

Caution

Handling

- Installation, placement, connections, wiring, or relocation of the product should be performed by knowledgeable or correctly licensed personnel. Never perform such work while the product is on. Failure to do so may result in bodily injury, fire, burns, or electrical shock.
- Never allow yourself to come into contact with the ends of wires or plugs when measuring insulation resistance or dielectric strength voltage. Otherwise, it may result in electrical shock.
- Never attempt to disassemble or alter the product in any way. Doing so may invalidate any warranties concerning the functions or performance of the product, and may also result in fire, burns, bodily injury, or electrical shock.

Instruction

- Take measures to protect the device from potential damage caused by the product stopping during operation.
- Never use the product at voltages, temperatures, or any other settings which exceed those given in the product specifications. Otherwise, it may result in substandard operation, failure, fire, bodily injury, or electrical shock.
- Never remove the product nameplate or install the product so that the identification cannot be seen after installation. Otherwise, it may result in the product being improperly used, and subsequently result in fires.
- Do not turn the power supply ON/OFF on a ground wire. Otherwise, it may result in product failure.
- Do not apply excessive force to the product while it is operating. Otherwise, it may result in product failure.
- If you install and use the product in a car or a ship, we shall not be responsible for any faults caused by the environment of the car or ship in which the product is installed.

Installation

- When fixing the product into place, be sure to take into consideration the product's weight and all other relevant factors. Failure to do so may result in the product or its parts falling, resulting in bodily injury or device failure.
- Never install or remove the product while it is wired.
- When fixing the product with screws, ensure correct tightening torque. If the tightening torque is over the recommended values, the product structure may deform or break.
- Take proper precautions against static electricity when making electrical connections. Failure to do so may result in device or product failure.
- Make electrical connections properly. Failure to do so may result in device failure, product failure, or product malfunction.
- Ensure that wires are fitted with insulation to prevent accidental short-circuiting. Failure to do so may result in device failure, product failure, or product malfunction.

Operating Environment

- Do not use or store the product where it is exposed to flammable or corrosive gas, water or oil splashes, dust or humidity, condensation, radioactive rays or direct sunlight, salty air or saltwater, or where the product may be contaminated by corrosive materials such as sulfurous water, sulfurous volcanic ash, organic solvents, acidic chemicals, alkali chemicals, nuclear fuel materials, or other hazardous substances. If it is used or stored in such places or environments, there is the possibility that a fire may occur, the product may malfunction or its performance may deteriorate.
- Do not use or store the product in locations and environments where it could be constantly exposed to vibrations, strong shocks, magnetic or electromagnetic noise, or in which electromagnetic noise overlaps into power voltage. Otherwise, it may result in product failure.
- Do not use or store the product in environments subject to sudden changes in temperature and humidity. Otherwise, it may result in product failure.



Maintenance

- Only certified personnel with sufficient training and knowledge should perform maintenance and inspections. Otherwise, it may result in fire, burns, bodily injury, or electrical shock.
- Perform maintenance or inspections while the product is off. Otherwise, it may result in fire, burns, bodily injury, or electrical shock.
- Never use gasoline, paint thinner, benzene, or any other organic solvents to clean the product. Otherwise, it may result in product deformation or substandard operation.

PCB type

- To ensure that the product is used safely, be sure to read and fully understand the Safety Precautions and only use the product as directed.
- Read the Safety Precautions carefully before installing, connecting, operating, maintaining, or inspecting the product.
- The product has been designed and manufactured for use in general industrial machinery, and may not be used as a standalone product.
- The product of our company (hereafter referred to as "the product") falls into the category of the products specified in the Attached List 1, Item 16 (Class 85, Item 43) of the Export Trade Control Ordinance. To export the product as an individual part or to export a product into which the product is assembled, the "Information Requirements" and "Objective Requirements" that the Ministry of Economy, Trade and Industry established based on the "Catchall Controls" must be studied for applicability. Based on information on applicability and specified requirements, appropriate export formalities must be performed.
- When disposing of the product, treat it as industrial waste. For instructions on proper disposal methods, please contact local government authorities.
- When using the product in an environment with vibration, such as in a car or a ship, use it at your own discretion only after deploying sufficient safety measures and making prior evaluations. Fully understand the Safety Precautions described in this instruction manual before using the product.

In order to prevent any possible bodily injury or damage to property or equipment, the following precautions for ensuring safety are displayed according to the following two ranks of importance:

 Danger	Handling or using the product improperly and in disregard of the instructions with this mark may result in serious bodily injury or death.
 Caution	Handling or using the product improperly and in disregard of the instructions with this mark may result in bodily injury or physical damage.

*Note: Items marked 'Caution' may also result in serious bodily injury or death in some circumstances. Always follow the instructions for items marked 'Danger.'

Danger

- If the product is used in medical appliances or other types of equipment that affect people's lives, sufficient safety-related evaluations and preparations must be made in advance, and the product or the type of equipment into which the product is assembled must be used under the full responsibility of the user.
- If the product is used in types of equipment that have a strong social and public impact, sufficient prior evaluations and safety-related evaluations and preparations must be made, and the product or the type of equipment into which the product is assembled must be used under the full responsibility of the user.
- The product is not designed to be used in a car or a ship. When using the product in an environment with vibration, such as in a car or a ship, use it at your own discretion only after deploying sufficient safety measures and making prior evaluations.
- Connect all wires properly and securely. Failure to do so may result in fire, burns, or electrical shock.
- Do not use this product in a location where there is flammable gas. Otherwise, it may result in fire, burns, or bodily injury.
- Only use the product integrated with another device or system. Failure to do so may result in burns or electrical shock.
- Do not touch the product while it is operating. Otherwise, it may result in burns or electrical shock.
- Turn off the power and stop using the product immediately if you notice any sparks, smoke, odd odors, sounds, or anything unusual during operation. Failure to do so may result in fire, bodily injury, or electrical shock.
- Never allow the product to fall, topple over, or otherwise be subjected to excessive shocks when moving it. Otherwise, it may result in product failure.
- The product should be handled only by personnel with sufficient training and knowledge and under the full responsibility of the user.
- Never attempt to disassemble, repair, or alter the product in any way. Failure to do so may result in fire, bodily injury, or electrical shock.

Caution

Handling

- Discharge static electricity from your body before handling the product. In addition, avoid packaging or covering the product with materials which generate static electricity. Contact with static electricity may result in product failure.
- Do not touch solder joints or pins. Otherwise, it may result in bodily injury.
- Installation, placement, connections, wiring, or relocation of the product should be performed by knowledgeable or correctly licensed personnel. Never perform such work while the product is on. Failure to do so may result in bodily injury, fire, burns, or electrical shock.
- Never allow yourself to come into contact with the ends of wires or plugs when measuring insulation resistance or dielectric strength voltage. Otherwise, it may result in electrical shock.
- Never attempt to disassemble or alter the product in any way. Doing so may invalidate any warranties concerning the functions or performance of the product, and may also result in fire, burns, bodily injury, or electrical shock.

Instruction

- Do not touch the product for a period after the power has been turned off as it may still be hot. Otherwise, it may result in burns.
- Take measures to protect the device from potential damage caused by the product stopping during operation.
- Never use the product at voltages, temperatures, or any other settings which exceed those given in the product specifications. Otherwise, it may result in substandard operation, failure, fire, bodily injury, or electrical shock.
- Never remove the product nameplate or install the product so that the identification cannot be seen after installation. Otherwise, it may result in the product being improperly used, and subsequently result in fires.
- Do not turn the power supply ON/OFF on a ground wire. Otherwise, it may result in product failure.
- Do not apply excessive force to the product while it is operating. Otherwise, it may result in product failure.
- If you install and use the product in a car or a ship, we shall not be responsible for any faults caused by the environment of the car or ship in which the product is installed.

Installation

- When fixing the product into place, be sure to take into consideration the product's weight and all other relevant factors. Failure to do so may result in the product or its parts falling, resulting in bodily injury or device failure.
- Never install or remove the product while it is wired.
- When fixing the product with screws, ensure correct tightening torque. If the tightening torque is over the recommended values, the product structure may deform or break.
- Install the product carefully without touching conductors or other electrical components. Touching these components may result in device failure, product failure, or product malfunction.
- Take proper precautions against static electricity when making electrical connections. Failure to do so may result in device or product failure.
- Make electrical connections properly. Failure to do so may result in device failure, product failure, or product malfunction.
- Ensure that wires are not allowed to short-circuit. Failure to do so may result in device failure, product failure, or product malfunction.

Operating Environment

- Do not use or store the product where it is exposed to flammable or corrosive gas, water or oil splashes, dust or humidity, condensation, radioactive rays or direct sunlight, salty air or saltwater, or where the product may be contaminated by corrosive materials such as sulfurous water, sulfurous volcanic ash, organic solvents, acidic chemicals, alkali chemicals, nuclear fuel materials, or other hazardous substances. If it is used or stored in such places or environments, there is the possibility that a fire may occur, the product may malfunction or its performance may deteriorate.
- Do not use or store the product in locations and environments where it could be constantly exposed to vibrations, strong shocks, magnetic or electromagnetic noise, or in which electromagnetic noise overlaps into power voltage. Otherwise, it may result in product failure.
- Do not use or store the product in environments subject to sudden changes in temperature and humidity. Otherwise, it may result in product failure.

Maintenance

- Only certified personnel with sufficient training and knowledge should perform maintenance and inspections. Otherwise, it may result in fire, burns, bodily injury, or electrical shock.
- Perform maintenance or inspections while the product is off. Otherwise, it may result in fire, burns, bodily injury, or electrical shock.
- Never use gasoline, paint thinner, benzene, or any other organic solvents to clean the product. Otherwise, it may result in product deformation or substandard operation.

Airflow Tester

■ Features (Patented as a movable measurement device for measuring device airflow and system impedance)

Enables the selection of the optimal fan for a device

An optimal fan for a device can be selected by entering accurate measurement results into thermal design simulation software.

Compact and lightweight

With a compact design and weight of approximately 6 kg, it is portable enough to measure immobile equipment.

■ Measurement Functions

- System Impedance Measurement of the resistance to the flow of air within a device
- Operating Airflow Measurement of the actual airflow that passes through a device when a fan is mounted
- P-Q Performance Measurement of airflow versus static pressure characteristics*

*: Performance curve that illustrates the characteristics of a fan for use within a certain system.

It shows the relationship between airflow and static pressure.

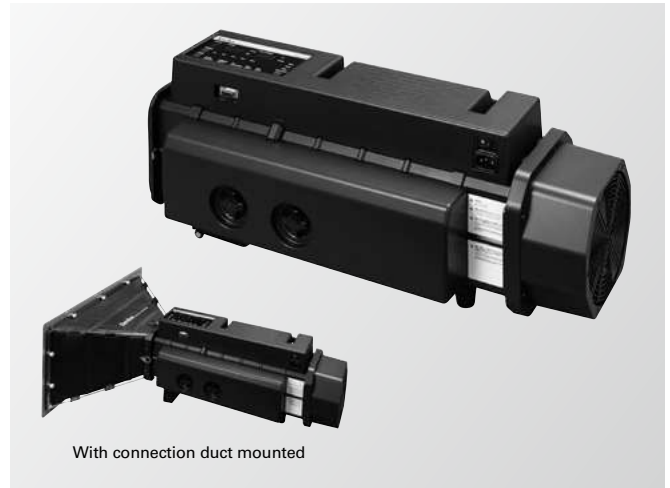

With connection duct mounted



■ Specifications

Model no.		9AT2560S-000□*1	9AT2560A-000□*1	9AT2560C-000□*1
Measurement units	Airflow	m ³ /min	CFM	CFM
	Static pressure	Pa	inchH ₂ O	Pa
Measurement range	Airflow	0.20 to 8.00 m ³ /min	7 to 282 CFM	7 to 282 CFM
	Static pressure	0 to 1,000 Pa	0 to 4.01 inchH ₂ O	0 to 1,000 Pa
Measurement accuracy	Airflow	±7% of maximum measurable airflow with each nozzle		
	Static pressure	±10 Pa (0.04 inchH ₂ O) for measurement results lower than 200 Pa, ±50 Pa (0.20 inchH ₂ O) for measurement results higher than 200 Pa		
Operating environment	Ambient temperature	0 to 40 °C		
	Humidity	20 to 85% RH (non-condensing)		
Display		Data no., Measurement values (airflow, static pressure* ²), Measurement status, Nozzle selection, Measurement mode selection		
Interface		Digital output: Included USB serial adapter		
Power supply	Input voltage	100 to 240 VAC, 50/60 Hz		
	Power consumption	260 VA max.		
Dimensions		600 (W) × 250 (H) × 250 (D) mm		
Mass		Main unit: Approx. 6 kg, Connection duct (including board holder): Approx. 1.5 kg		
Included peripherals		1 Set of measurement nozzles, Plastic mounting board (5 pcs / set), Connection duct, AC power cable (2.5 m), USB serial adapter, Instruction manual, Quick start guide, Data viewer software		

*1: The AC power plug shape differs with the number in □ of model numbers.

AC power plug included in models with 1 in □ is for Japan and North America regions (2 parallel flat pins + a round grounding pin), Input voltage: 100/120 VAC, 50/60 Hz

AC power plug included in models with 2 in □ is for Europe region (2 round pins + a female grounding contact), Input voltage: 220 VAC, 50 Hz

AC power plug included in models with 3 in □ is for China region (2 angled flat pins + a flat grounding pin), Input voltage: 220 VAC, 50 Hz

Product also available without an AC power cable. Model no. 9AT2560S-0000, 9AT2560A-0000, 9AT2560C-0000

*2: Static pressure values are calculated with standard atmosphere as 1013 hPa at 20 °C.

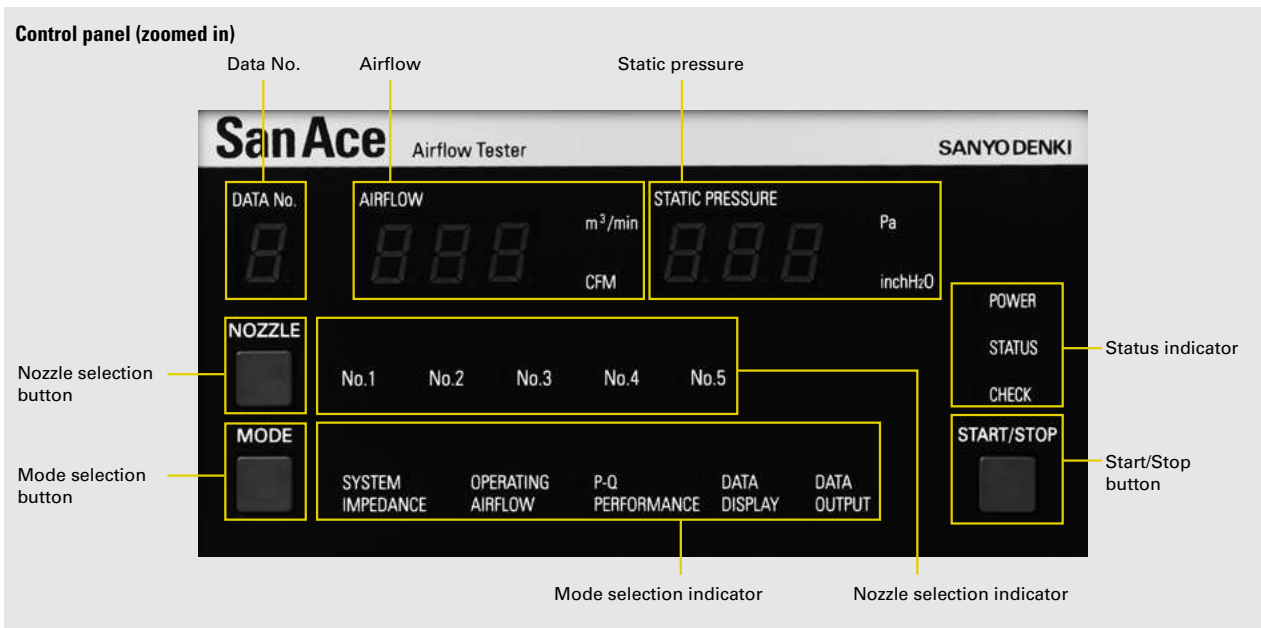
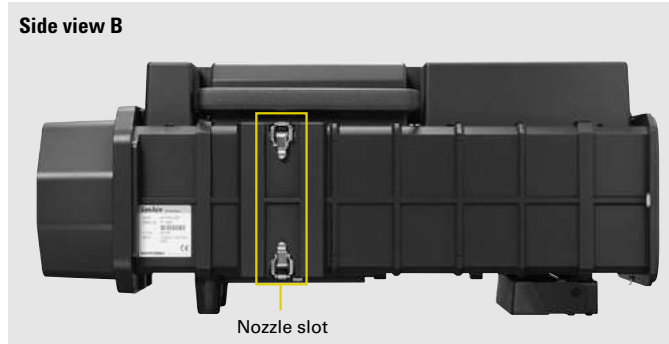
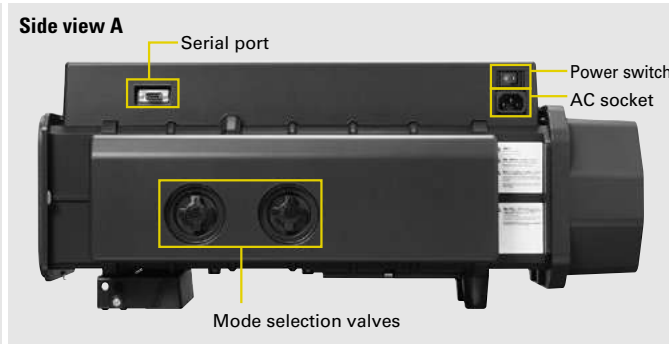
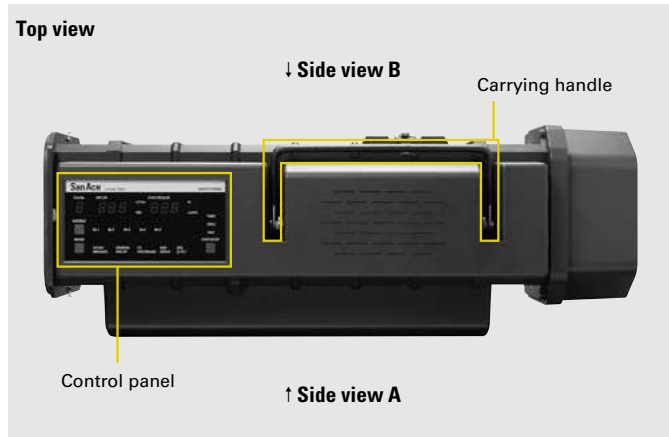

Usage Examples

Cut out a hole in the mounting board matching the vent opening of the device to be measured, and place the mounting board firmly against the device to perform measurements.

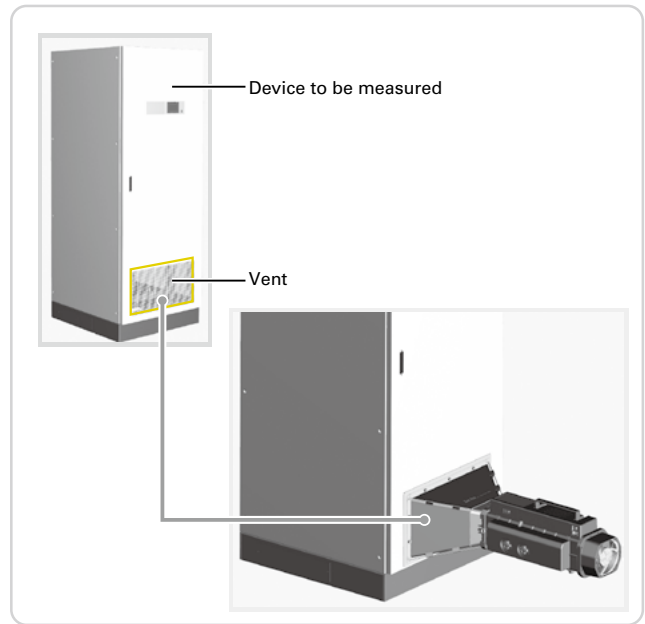
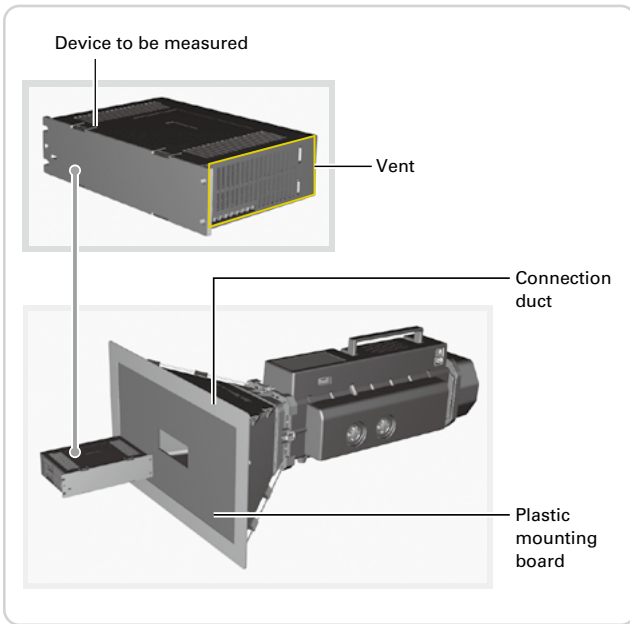

Data viewer software (included)

Obtained measurement data can be represented as a graph and saved on a PC.

Screen examples P-Q performance shown below based on catalog data.

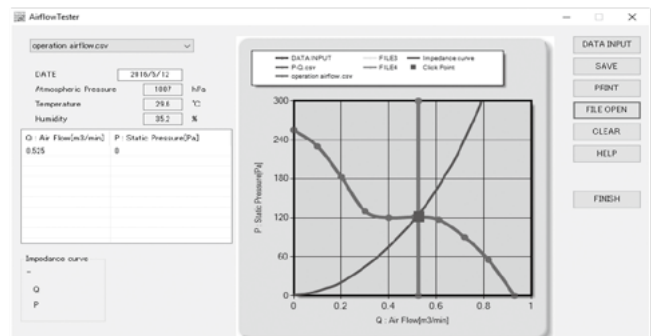
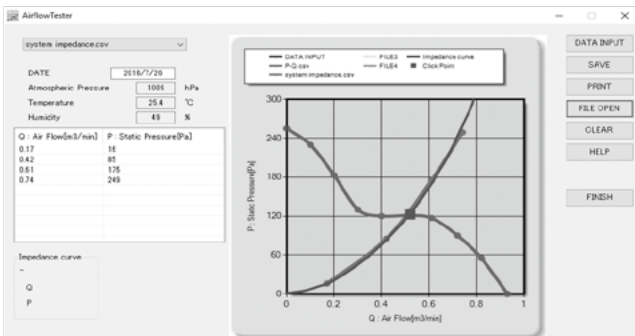

Option

Carrying case Measurement nozzle case included

Model no.	9AT2560-B001 Please add "CS" to the end of the model no. of Airflow Tester in page 1 when ordering Airflow Tester and carrying case as a set. e.g. 9AT2560S-0001CS
Dimensions	705 (W) × 385 (H) × 415 (D) mm



Carrying case, measurement nozzle case

Plastic mounting boards

Sized to fit the duct frame. Five boards included with Airflow Tester.

Model no.	9AT2560-P001
Quantity	5 pcs / set
Dimensions	525 (W) × 275 (H) × 4 (D) mm

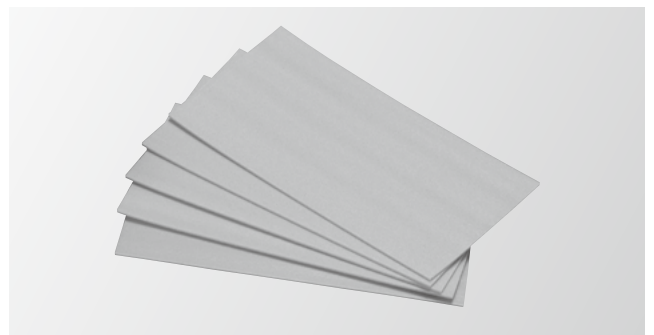

Plastic mounting boards (5 pcs)

■ Dimensions (unit: mm)

● Main unit

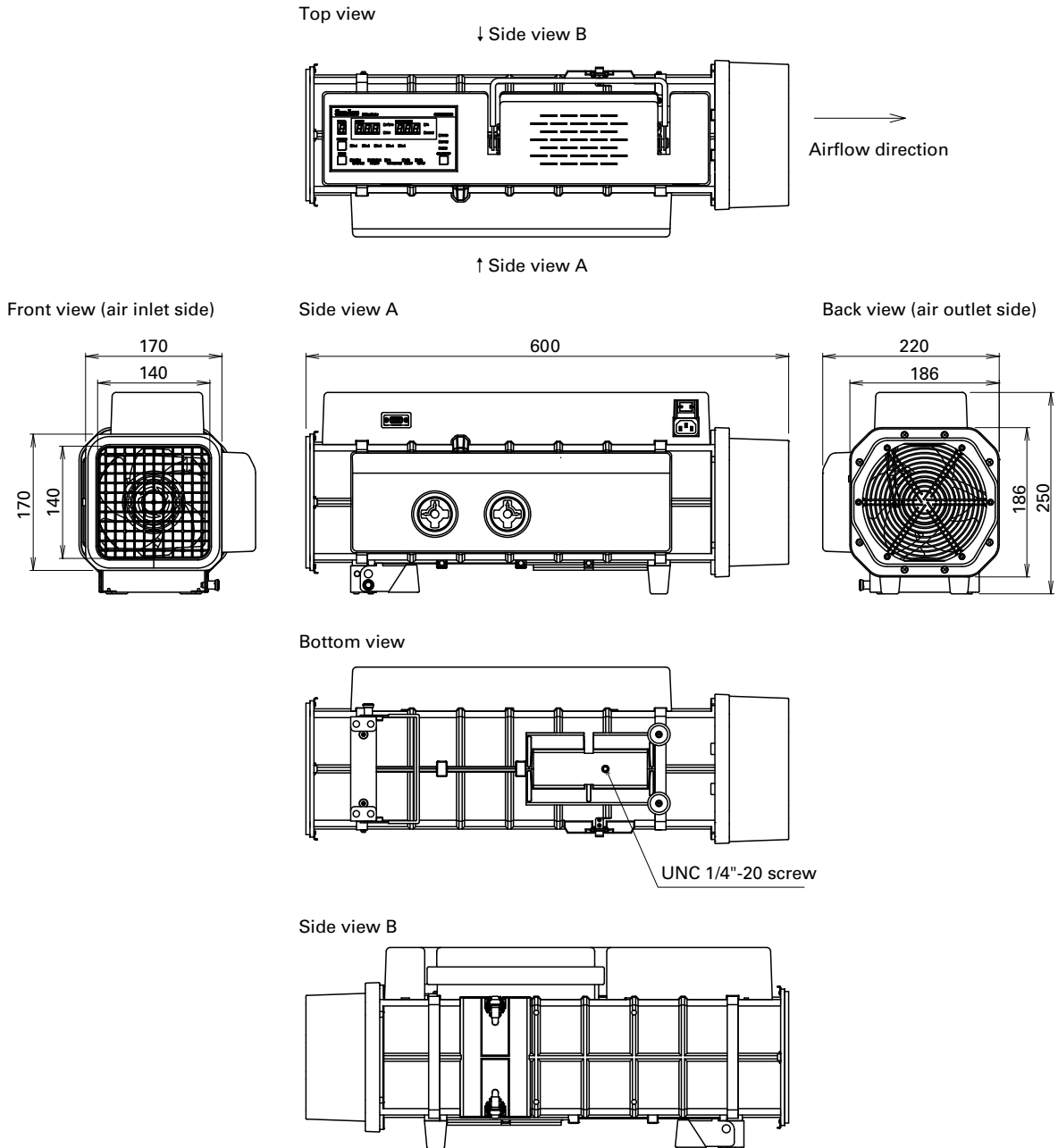

● Connection duct

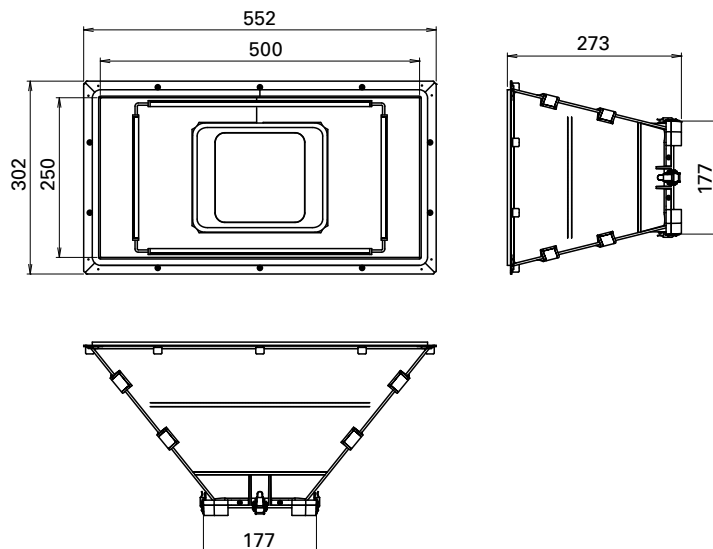



Safety Precautions

Please read the instruction manual and its appendix carefully prior to installation, operation, maintenance or inspection and perform all tasks according to the instructions provided here.

A good understanding of this equipment, its safety information as well as all Warnings/Cautions is also necessary prior to operation.



Matters that require attention are ranked as "Danger", "Warning", and "Caution" in this document.

Warning Symbols

 Warning	Denotes immediate hazards which could cause severe bodily injury or death as a result of incorrect operation.
 Caution	Denotes hazards which could cause bodily injury and product or property damage as a result of incorrect operation.

 **Caution** Even those hazards denoted by this symbol could lead to a serious accident. Make sure to strictly follow these safety precautions.

Prohibited, Mandatory Symbols

	Indicates actions that must not be allowed to occur / prohibited actions.
	Indicates actions that must be carried out / mandatory actions.

Warning

Operating Precautions

- Avoid using the product in the presence of flammable, explosive, or corrosive gases, locations subjected to splashing water or oil, or near combustibles. Otherwise, it may result in electric shock, bodily injury, fire, product failure, or damage.
- Turn off the power before performing any wiring, maintenance, or inspection. Once the power is off, remove the AC power cable, and confirm that the POWER LED is off before performing these tasks. Failure to do so may result in electric shock.
- Operate the product with dry hands. Failure to do so may result in electric shock.
- Never attempt to disassemble or alter the product in any way. Otherwise, it may result in electric shock, bodily injury, fire, product failure, or damage.
- Do not damage the AC power cable. Otherwise, it may result in electric shock, bodily injury, fire, product failure, or damage.
- If the product emits unusual noise, odors, or smoke, or if water or other liquids enter the product, immediately turn off the power and disconnect the power cable. Otherwise, it may result in electric shock, bodily injury, fire, product failure, or damage.
- Read the instruction manual carefully prior to using the product. Failure to do so may result in electric shock, bodily injury, fire, product failure, or damage.
- Always use the supplied AC power cable if included. Using an AC power cable with inappropriate ratings may result in electric shock, bodily injury, fire, product failure, or damage.
- If an AC power cable is not included, please prepare a cable matching the specifications listed in section 9.2 "Specifications" of Instruction Manual. Using an AC power cable with inappropriate ratings may result in electric shock, bodily injury, fire, product failure, or damage.
- Prior to turning on the power, be sure to ground the product by connecting it to a grounded outlet. Insufficient grounding may result in electric shock, bodily injury, fire, product failure, or damage.

Caution

Operating Precautions

- Avoid using the product near bodies of salt water or other locations susceptible to salt damage. Otherwise, it may result in product failure or damage caused by salt.
- Due to the internal power supply, certain sections of the product may experience an elevation in temperature that may cause a burn or bodily injury.
- Do not use the product outside its specifications. Otherwise, it may result in electric shock, bodily injury, fire, product failure, or damage.
- Do not use the product if it is defective, damaged, or burnt out. Otherwise, it may result in electric shock, bodily injury, or fire.
- When not using the product, turn off the power and unplug the AC power cable. Failure to do so may result in electric shock, bodily injury, fire, product failure, or damage.

Transportation

- Excess stacking may cause the load to collapse so follow the directions written on the outside box. Failure to do so may result in bodily injury or damage.
- Handle the product with care during transportation, as it is dangerous if dropped. Failure to do so may result in bodily injury.
- The product is heavy so handle with care. Failure to do so may result in bodily injury.

Handling

- Do not apply excessive stress or place heavy objects on the product. Otherwise, it may result in electric shock, bodily injury, product failure, or damage.
- Transport the product using the carrying handle. Failure to do so may result in bodily injury, product failure, or damage.
- Do not drop the product or subject it to excessive shock of any kind. Otherwise, it may result in product failure or damage.
- If the connection duct or tripod is attached to the main unit, make sure it does not tip over or drop while moving. Otherwise, it may result in bodily injury, product failure, or damage.
- Only use the product as specified in this instruction manual. Failure to do so may result in product failure or damage.
- Make sure that the intake and exhaust vents are free of debris and foreign matter. Otherwise, it may result in bodily injury, product failure, or damage.
- Mount the product on incombustible material below 60°C. Failure to do so may result in fire, product failure, or damage.

Connecting the AC Power Cable

- Connect the AC power cable as instructed by the instruction manual. Failure to do so may result in electric shock, bodily injury, fire, product failure, or damage.

Operation

- Operate the product within the specified input-power voltage to maintain stability. Otherwise, it may result in electric shock, bodily injury, fire, product failure, or damage.
- The auxiliary fan rotates during operation. Make sure that the intake and exhaust vents are free of debris and foreign matter.
- Keep hands away from the exhaust vent. Failure to do so may result in bodily injury, fire, product failure, or damage.

Maintenance and Inspection

- Some parts of the product (fan motor, gasket, electrolytic condenser, sensor, LED, switches) can deteriorate with long-term use. As preventive maintenance, perform periodic maintenance and inspection to maintain measuring accuracy. For details on maintenance, inspection, and repair, please contact SANYO DENKI. Disassembly is not to be performed by the end-user. Disassembly may result in electric shock, bodily injury, fire, malfunction, product failure, or damage.

Prohibited

Handling

- Do not scratch the connection duct with sharp objects as it may tear or damage the material.

Operation

- Applying voltage outside the input voltage range may result in electric shock, bodily injury, fire, product failure, or damage. Never use voltages outside of specification.
- Keep the USB serial adapter away from static electricity and high voltage. Failure to do so may result in failure or damage.
- Do not use a polarized grounding adapter with the product. Otherwise, it may result in electric shock, bodily injury, fire, product failure, or damage.

Storage

- Do not store the product where it could be exposed to rain, water, toxic gases, or other liquids. Failure to do so may result in product failure or damage.

Maintenance and Inspection

- Do not perform disassembly, inspection, or repairs. Otherwise, it may result in electric shock, bodily injury, fire, product failure, or damage.
- Do not measure the insulation resistance or the pressure resistance. Otherwise, it may result in product failure or damage.
- Never unplug the AC power cable while the power is on as the resulting surge voltage may damage electronic components. Otherwise, it may result in electric shock, bodily injury, or fire.
- Do not remove the nameplate attached to the product. Doing so voids the warranty.
- Do not wipe the product with benzene, paint thinner, or other solvents. Otherwise, it may result in deformation, deterioration, discoloration, product failure, or damage.

Mandatory

Operation

- In the case of any irregular operation, stop the device immediately. Otherwise, it may result in electric shock, bodily injury, fire, product failure, or damage.
- As a provisional measure, ensure that the power can be turned off at any time. Inability to turn off the power may result in electric shock, bodily injury, fire, product failure, or damage.
- If an error occurs, eliminate the cause and ensure safety before resuming.
- Use the product within the specified temperature and humidity range. Failure to do so may result in product failure or damage.
Temperature: 0°C to 40°C / Humidity 20 to 85% RH (non-condensing)
- Be sure to use the supplied AC power cable to prevent electric shock, bodily injury, fire, product failure, or damage.
- Be sure to prepare a cable matching the ratings listed in section 9.2 "Specifications" of Instruction Manual to prevent electric shock, bodily injury, fire, product failure, or damage.
- Prior to turning on the power, be sure to ground the product by connecting it to a grounded outlet to prevent electric shock, bodily injury, fire, product failure, or damage.

Storage

- Store the product in a location that is not exposed to direct sunlight, at a temperature and humidity within specifications. Failure to do so may result in product failure.
- If the product has been stored for a long period, contact SANYO DENKI. There is the possibility that components may have deteriorated and require maintenance.

Disposal

- When disposing of the product, treat it as industrial waste.

Cooling Fan Units

CUSTOMIZED PRODUCTS

Features

DC AC

We provide assembled fan units in accordance with the specification or requirements of the equipment. For use in communications equipment, servers, storage systems.

Example



Electrolytic Corrosion Proof Fans

CUSTOMIZED PRODUCTS → p. 484

Features

DC AC

This cooling fan prevents electrolytic corrosion of bearings even under conditions where electromagnetic noise is generated. Electrolytic corrosion of ball bearings is prevented by using ceramic balls in ball bearings. The ceramic material is an insulating material. Manufacturable to meet specifications of all San Ace series fans.

Dimensions (unit : mm)

36mm sq. type

Model : 109-1050 Surface treatment : Nickel-chrome plating (silver) Color (silver)

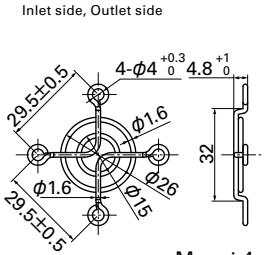

Mass : 4g

38mm sq. type

Model : 109-1065 Surface treatment : Nickel-chrome plating (silver) Color (silver)

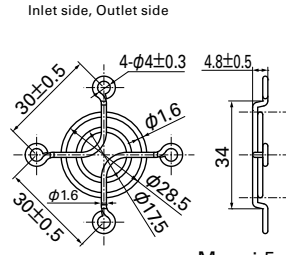

Mass : 5g

40mm sq. type

Model : 109-059 Surface treatment : Nickel-chrome plating (silver) Color (silver)
Model : 109-059H Surface treatment : Cation electropainting (black) Color (black)

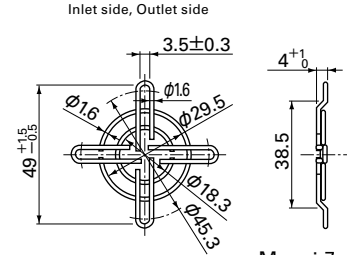

Mass : 7g

52mm sq. type

Model : 109-149 Surface treatment : Nickel-chrome plating (silver) Color (silver)

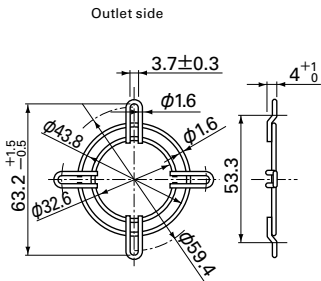

Mass : 7g

52mm sq. type

Model : 109-149E Surface treatment : Nickel-chrome plating (silver) Color (silver)

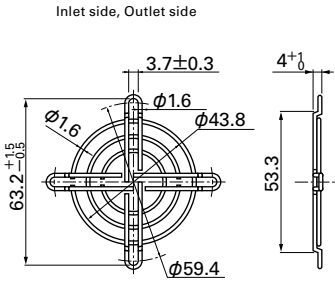

Mass : 9g

60mm sq. type

Model : 109-139E Surface treatment : Nickel-chrome plating (silver) Color (silver)
Model : 109-139H Surface treatment : Cation electropainting (black) Color (black)

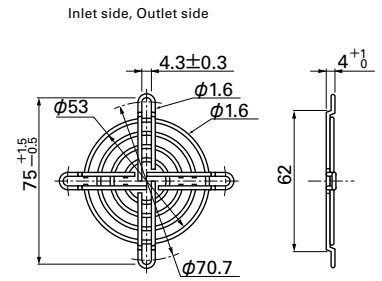

Mass : 14.5g

70mm sq. type

Model : 109-1128 Surface treatment : Nickel-chrome plating (silver) Color (silver)

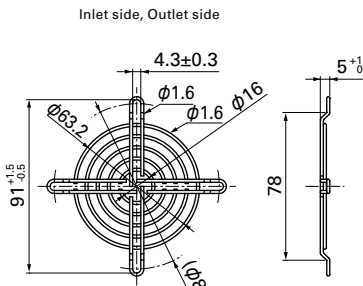

Mass : 17g

80mm sq. type

Model : 109-049C Surface treatment : Nickel-chrome plating (silver) Color (silver)

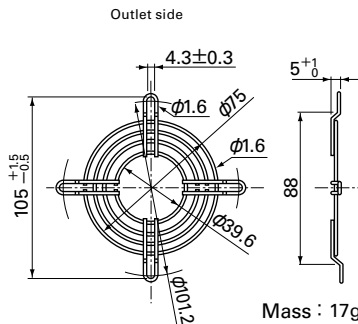

Mass : 17g

80mm sq. type

Model : 109-049E Surface treatment : Nickel-chrome plating (silver) Color (silver)
Model : 109-049H Surface treatment : Cation electropainting (black) Color (black)

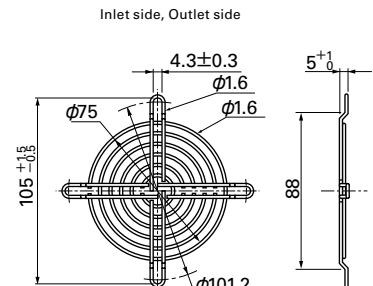

Mass : 21g

92mm sq. type

Model : 109-099C Surface treatment : Nickel-chrome plating (silver) Color (silver)

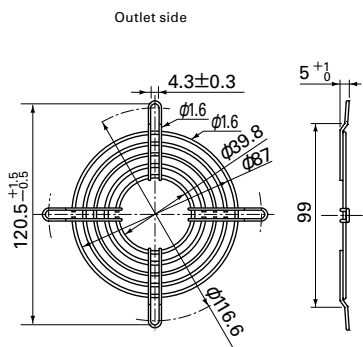

Mass : 22g

92mm sq., φ100mm type

Model : 109-099E Surface treatment : Nickel-chrome plating (silver) Color (silver)
Model : 109-099H Surface treatment : Cation electropainting (black) Color (black)

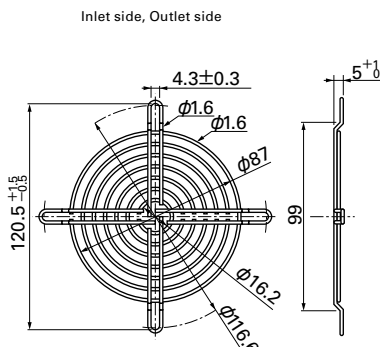

Mass : 29g

120mm sq. type

Model : 109-019C Surface treatment : Nickel-chrome plating (silver) Color (silver)
Model : 109-019H Surface treatment : Cation electropainting (black) Color (black)

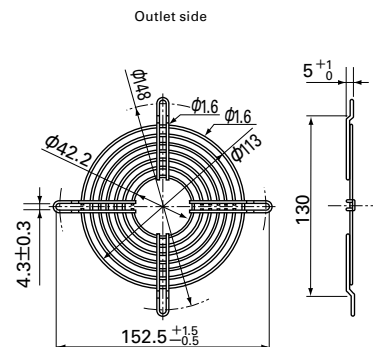

Mass : 32g

Dimensions (unit : mm)

120mm sq. type

Model : 109-019E Surface treatment : Nickel-chrome plating Color (silver)
 : 109-019K : Cation electroplating (black)

Inlet side, Outlet side

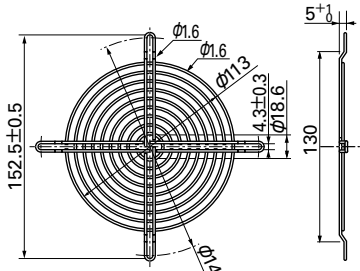

Mass : 42g

127mm sq., φ175mm type

Model : 109-722 Surface treatment : Nickel-chrome plating Color (silver)

Inlet side, Outlet side

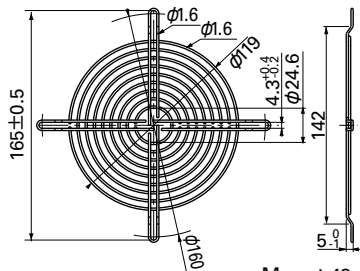

Mass : 43g

127mm sq. type

Model : 109-723 Surface treatment : Nickel-chrome plating Color (silver)

Outlet side

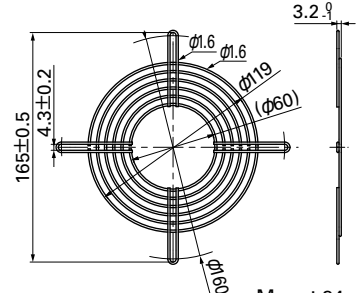

Mass : 34g

φ133mm type

Model : 109-1112 Surface treatment : Nickel-chrome plating Color (silver)

Inlet side

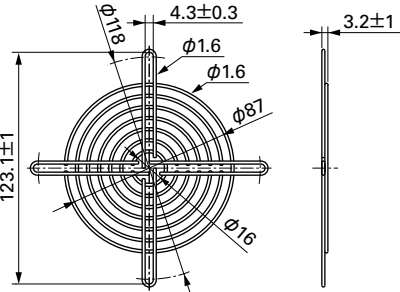

Mass : 65g

φ136mm type

Model : 109-1139 Surface treatment : Nickel-chrome plating Color (silver)

Impeller side, Nameplate side

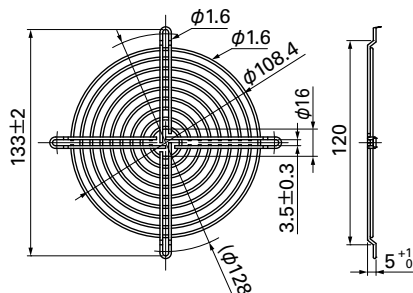

Mass : 41g

140mm sq. type

Model : 109-719 Surface treatment : Nickel-chrome plating Color (silver)

Inlet side, Outlet side

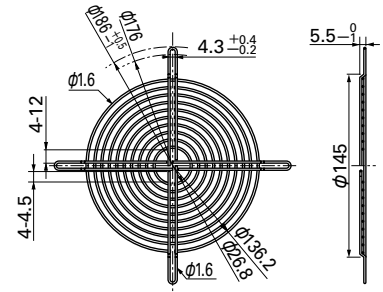

Mass : 51g

140mm sq. type

Model : 109-719H Surface treatment : Cation electroplating Color (black)

Inlet side, Outlet side

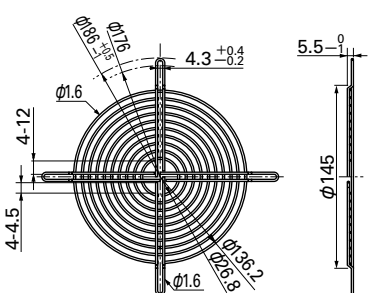

Mass : 51g

150mm sq. type

Model : 109-1051 Surface treatment : Nickel-chrome plating Color (silver)

Inlet side, Outlet side

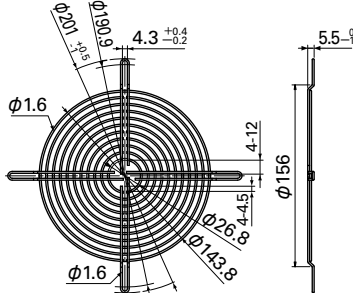

Mass : 63g

150mm sq. type

Model : 109-1052 Surface treatment : Nickel-chrome plating Color (silver)

Outlet side

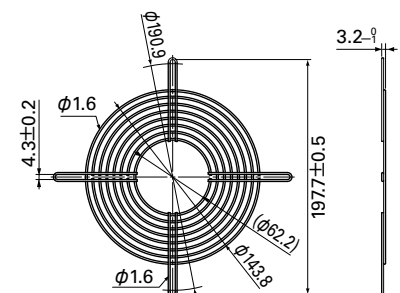

Mass : 53g

φ150mm type

Model : 109-1104 Surface treatment : Nickel-chrome plating Color (silver)
 : 109-1104H : Cation electroplating (black)

Inlet side

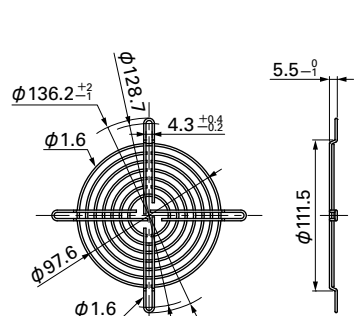

Mass : 31g

160mm sq. type

Model : 109-619E Surface treatment : Nickel-chrome plating Color (silver)
 Model : 109-619H : Cation electroplating (black)

Inlet side, Outlet side

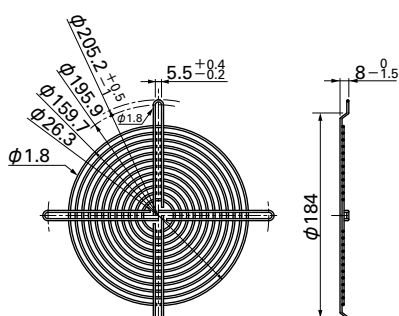

Mass : 85g

160mm sq. type

Model : 109-620 Surface treatment : Nickel-chrome plating Color (silver)

Outlet side

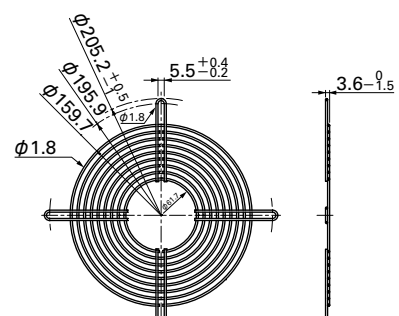

Mass : 74g

Dimensions (unit : mm)

φ172mm SideCut type

Model : 109-319J Surface treatment : Nickel-chrome plating (silver) Color
 Applicable Model: 9SG57**P5***/9GV57**H501 : Cation electroplating (black)
 9CR5748PG001/9WVG5748P5*001

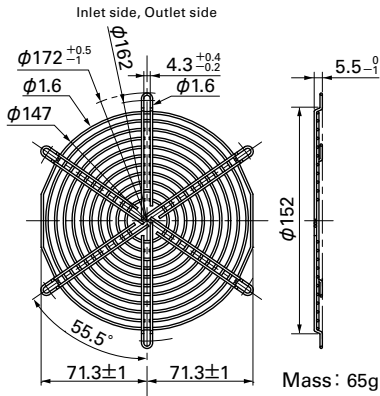

Finger guard 109-319J should be mounted with four holes as in the drawing.

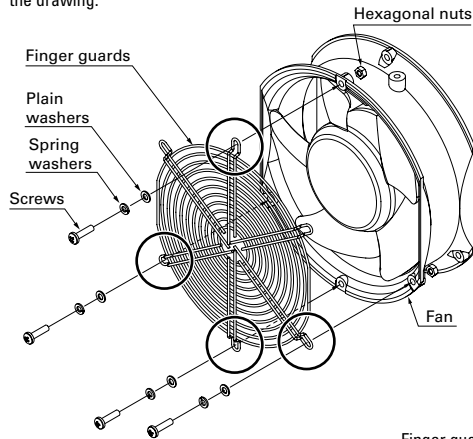

φ172mm SideCut, Round type

Model : 109-319E Surface treatment : Nickel-chrome plating (silver) Color
 : 109-319H : Cation electroplating (black)

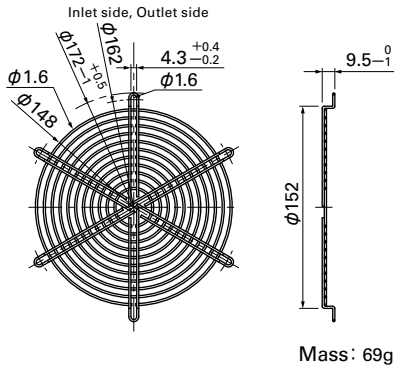

φ172mm SideCut, Round type

Model : 109-320 Surface treatment : Nickel-chrome plating (silver) Color

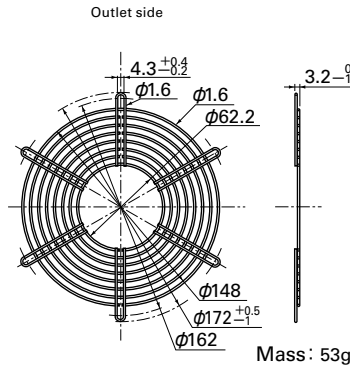

Finger guards 109-319E, 109-319H, and 109-320 should be mounted with two holes as in the drawing and do not use any other holes.

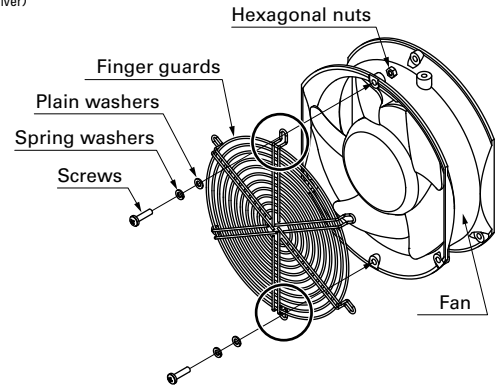

φ172mm Round type

Model : 109-1066 Surface treatment : Nickel-chrome plating (silver) Color

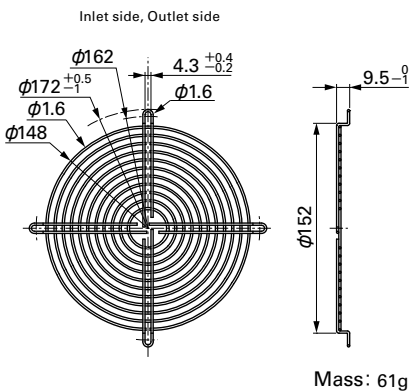

φ172mm Round type

Model : 109-1068 Surface treatment : Nickel-chrome plating (silver) Color

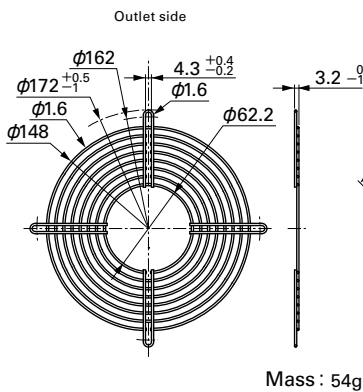

φ200mm type

Model : 109-1102 Surface treatment : Nickel-chrome plating (silver) Color
 Applicable Model: 9GV2048P0G201

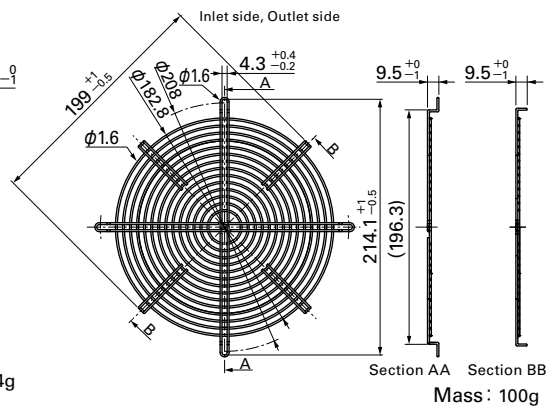

φ200mm type

Model : 109-1103 Surface treatment : Nickel-chrome plating (silver) Color
 Applicable Model: 9GV2048P0G201

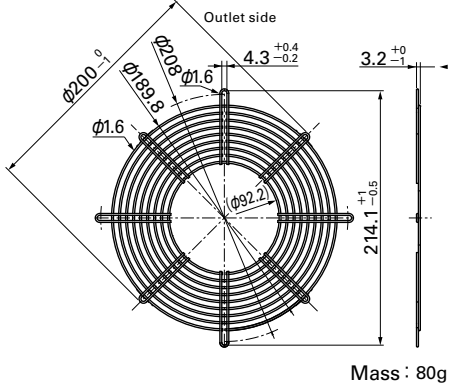

φ200mm type

Model : 109-720 Surface treatment : Nickel-chrome plating (silver) Color
 : 109-720H : Cation electroplating (black)
 Applicable Model: 109E2024***/9EC20***001

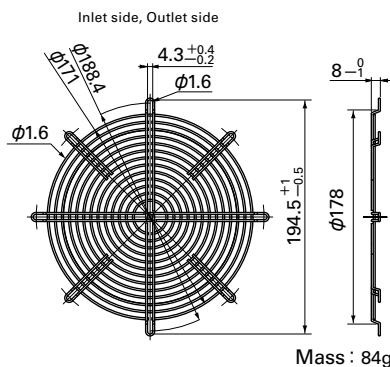

φ200mm type

Model : 109-721 Surface treatment : Nickel-chrome plating (silver) Color
 : 109-721H : Cation electroplating (black)
 Applicable Model: 109E2024***/9EC20***001

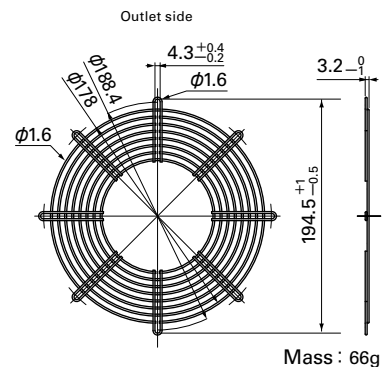

Option

Finger guards

DC AC

Dimensions (unit : mm)

φ221mm type

Model : 109-1138 Surface treatment : Nickel-chrome plating (silver) Color (silver)

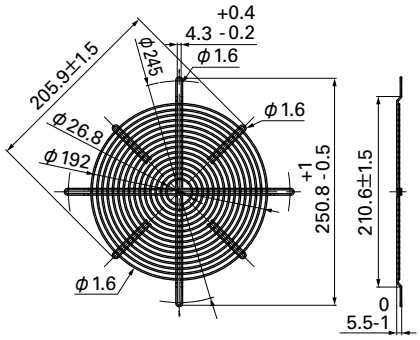

Mass : 105g

φ225mm type

Model : 109-1137 Surface treatment : Nickel-chrome plating (silver) Color (silver)

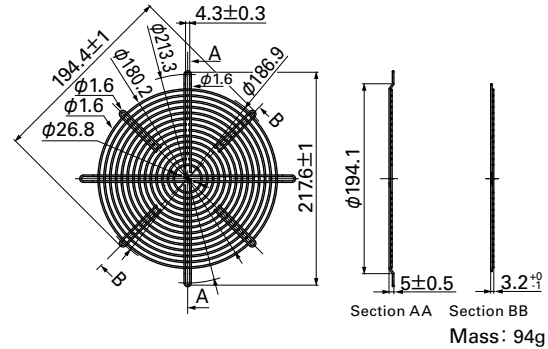

Mass : 94g

270mm sq. type (for Bracket-mounted Centrifugal Fan)

Model : 109-1146 Surface treatment : Nickel-chrome plating (silver) Color (silver)

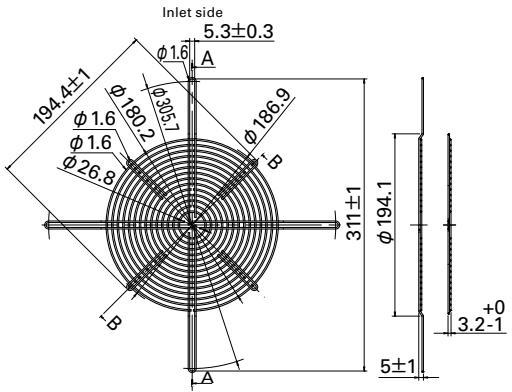

Mass : 106g

Finger guard 109-1146 should be mounted with four holes as in the drawing.

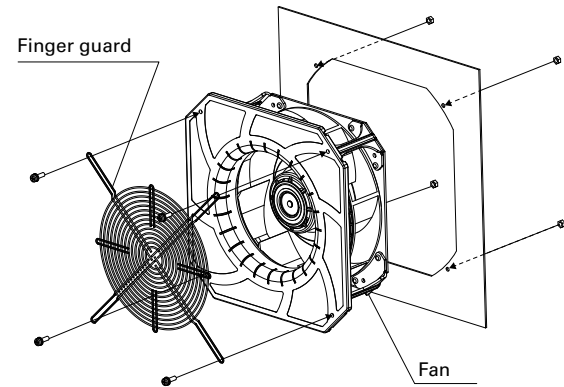

Mounting example

Axial fan

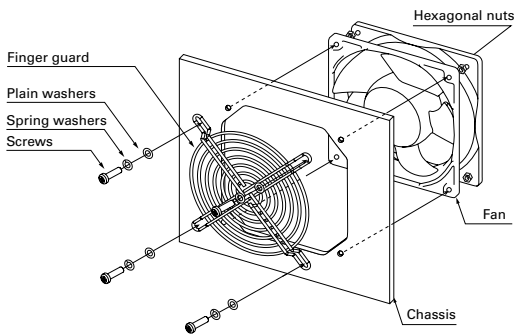

Centrifugal fan

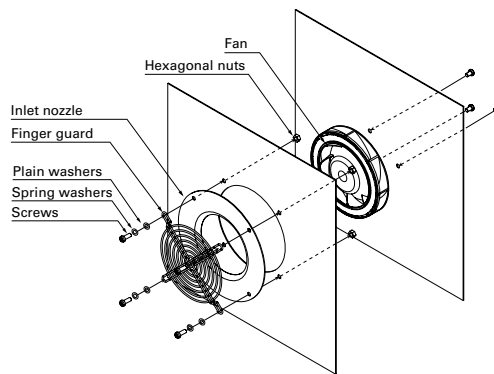

Inlet nozzle for centrifugal fan and splash proof centrifugal fan

DC

Nozzle mounted in fan inlet side to adjust the flow of introduced air. Material: Steel sheet

Dimensions (unit : mm)

φ100mm type

Model : 109-1080 Surface treatment : Electro nickel plating (silver) Color (silver)

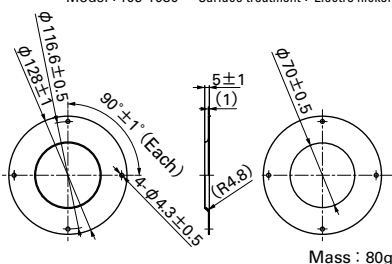

φ133mm type

Model : 109-1069 Surface treatment : Electro nickel plating (silver) Color (silver)
: 109-1069H : Cation electropainting (black)

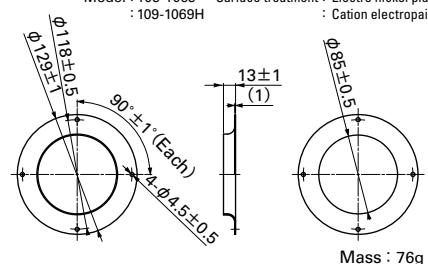

φ150mm type

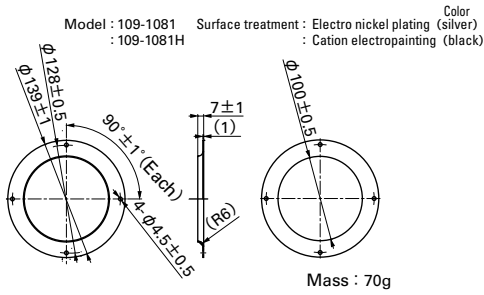

φ175mm type

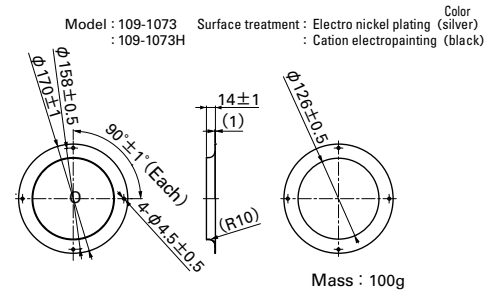

φ221mm type

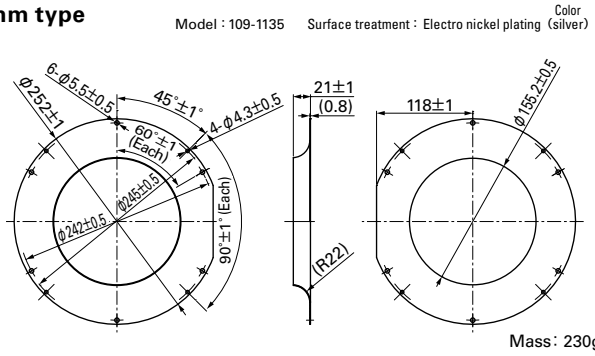

φ225mm type

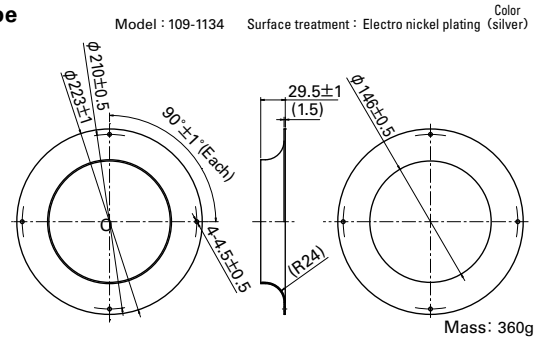

EMC guards

It is a metallic piece that protects materials from the adverse effects of electromagnetic noise sources. It provides electromagnetic shielding. It is attached to the casing of a device by means of the fan fixing screw(s). Ground the devices equipped with an EMC guard.

Dimensions (unit : mm)

80mm sq. type

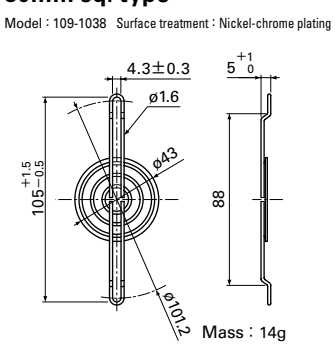

80mm sq. type

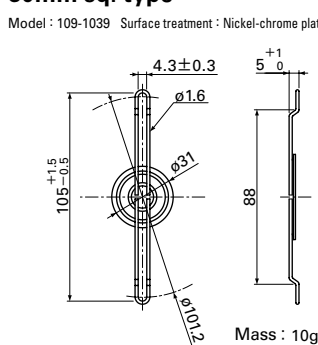

92mm sq. type

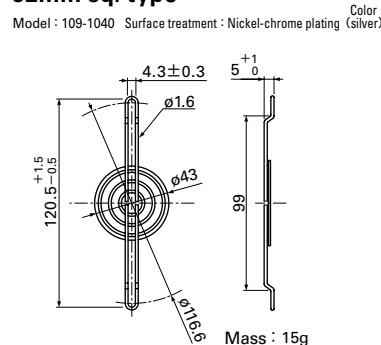

120mm sq. type

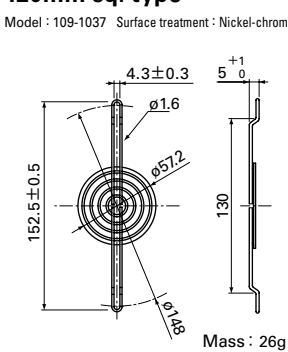

φ172mm type

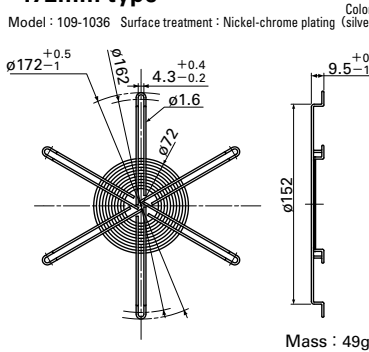

EMC guard

Dimensions of fans (mm)	Representative fans model numbers	EMC guards model numbers
80×80×15	109P08*	109-1039
	9GA08*	109-1038
80×80×20	109L08*	109-1038
	9GV08*	109-1038
80×80×25	109R08*	109-1039
	9A08*	
	9GA08*	
80×80×32	109P08*	109-1038
	9GA08*	109-1039
80×80×38	9G08*	109-1039
	9GA08*	
	9GV08*	
92×92×25	109L09*	109-1040
	109P09*	
92×92×32	9G09*	109-1040
	9G09*	
92×92×38	9G09*	109-1040
	9GV09*	
	9GA09*	
120×120×25	9G12*	109-1037
	9GV12*	
120×120×38	9GL12*	109-1037
	9LB12*	
	9G12*	
	9GV12*	
	9HV12*	
φ172×25	109E47*	109-1036
φ172×51	109L17*	109-1036
	9GV57*	
	109E17*	
	109E57*	
	9SG57*	

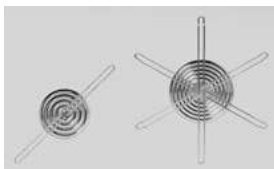

EMC guard

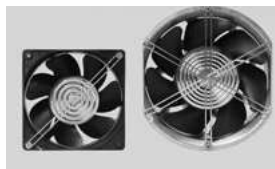

attached to a cooling fan

Resin finger guards

DC AC

Dimensions(unit : mm)

Material Frame : Resin (PPE+PS) UL File No.E82268 94V-0

60mm sq. type

Model : 109-1003G

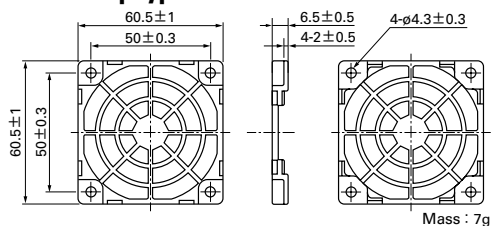

80mm sq. type

Model : 109-1002G

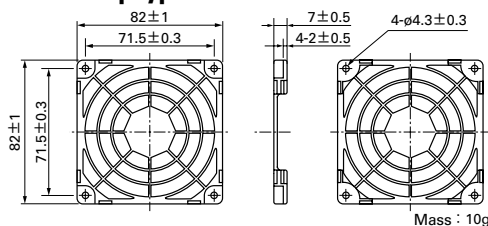

92mm sq. type

Model : 109-1001G

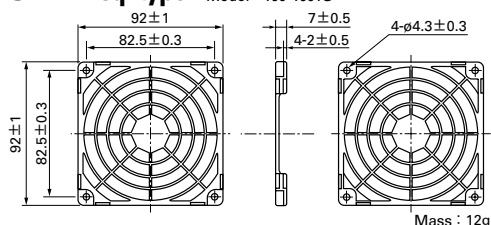

120mm sq. type

Model : 109-1000G

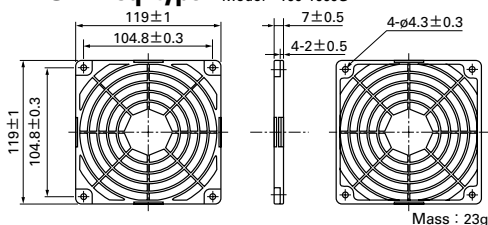

Airflow and Static Pressure Characteristics

Mounting example

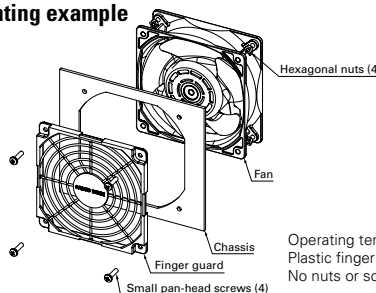
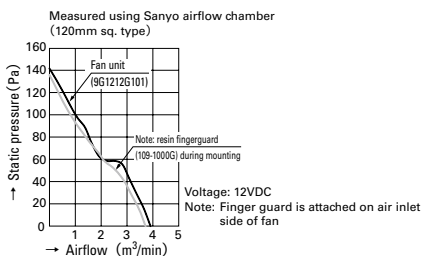

Operating temperature limit is between -20°C to +70°C (non condensing). Plastic finger guards are placed on both the intake and exhaust sides of the fan. No nuts or screws for use in attachment included.

Resin filter kits

DC AC

Dimensions (unit : mm)

Material Guard, cover : Resin (PPE+PS) UL File No.E82268 94V-0
Filter : Polyurethane foam UL File No.E74916(S) 94HF-1

60mm sq. type

Model : 109-1003F13 (13PPI) 109-1003F20 (20PPI)
: 109-1003F30 (30PPI) 109-1003F40 (40PPI)

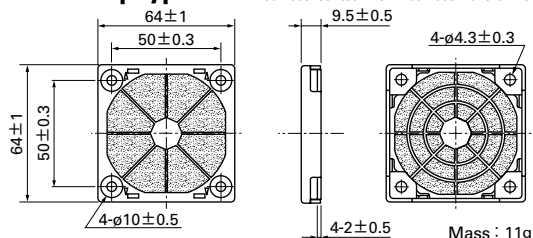

80mm sq. type

Model : 109-1002F13 (13PPI) 109-1002F20 (20PPI)
: 109-1002F30 (30PPI) 109-1002F40 (40PPI)

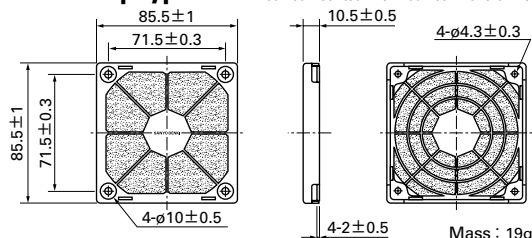

- Replacement filter (5 sheets each)
- 60mm sq. type
 - 109-1003M13 (13PPI)
 - 109-1003M20 (20PPI)
 - 109-1003M30 (30PPI)
 - 109-1003M40 (40PPI)

92mm sq. type

Model : 109-1001F13 (13PPI) 109-1001F20 (20PPI)
: 109-1001F30 (30PPI) 109-1001F40 (40PPI)

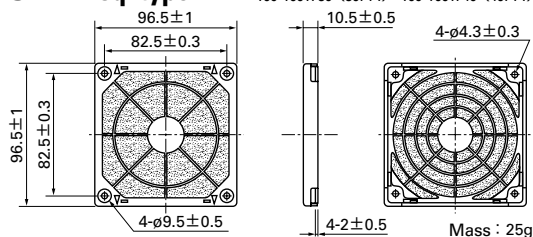

120mm sq. type

Model : 109-1000F13 (13PPI) 109-1000F20 (20PPI)
: 109-1000F30 (30PPI) 109-1000F40 (40PPI)

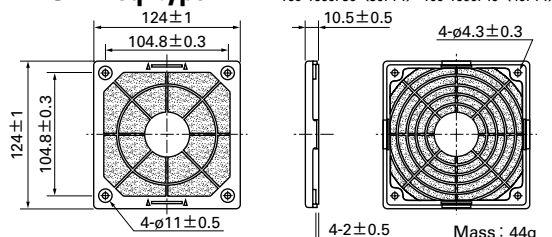

- 80mm sq. type
- 109-1002M13 (13PPI)
 - 109-1002M20 (20PPI)
 - 109-1002M30 (30PPI)
 - 109-1002M40 (40PPI)

- 92mm sq. type
- 109-1001M13 (13PPI)
 - 109-1001M20 (20PPI)
 - 109-1001M30 (30PPI)
 - 109-1001M40 (40PPI)

- 120mm sq. type
- 109-1000M13 (13PPI)
 - 109-1000M20 (20PPI)
 - 109-1000M30 (30PPI)
 - 109-1000M40 (40PPI)

PPI Particles Per Inch : Indicates the number of holes per inch. Note that the higher the number, the finer the grain of the sponge.

Airflow and Static Pressure Characteristics

Reference Diagram For Mounting

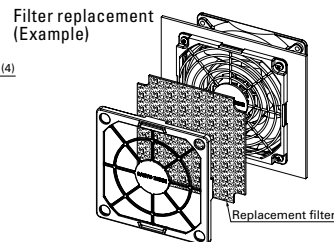
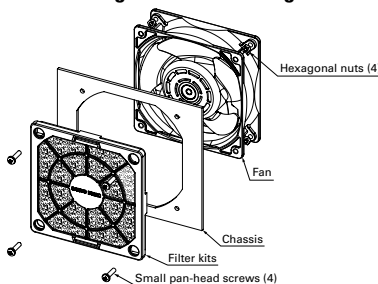
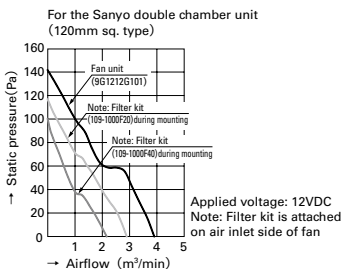

● Replacement filters can be replaced by taking off the front part of the filter kit. There is no need to remove the screws.

● Filter kit is one of the option to keep air in the chassis clean filtering dust in external atmosphere when pulling-air cooling is implemented. The filter kit is hooked up through mounting hole of fan frame with screw as well as finger guard. Some performances (airflow & static pressure) of the fan motor decreases when filter kit is hooked up. ● This Filter Kit is composed of 3 components, including a guard, a filter and a cover. It is delivered as a finished product at delivery, saving assembly time when mounting. It can be mounted by inserting a screw in the apertures of the cover. ● The filter and cover can be easily removed from the guard with one touch. There is no need for fan removal when undertaking maintenance. ● Operating temperature limit is between -10°C to +60°C (non condensing). ● The filter will deteriorate with age, and the level of deterioration will vary upon usage conditions. Please be aware that the filter has a greater tendency to deteriorate under high temperature and humidity. For long-term storage, please store under the temperature range of 10°C to 30°C, humidity range of 20% to 65%. Usage and storage period is approximately 2 years. ● Cooling ability decreases with filter contamination due to clogging. Filter replacement is recommended approximately every six months of usage. Please replace the filter if deterioration or clogging is seen at inspection. ● When replacing the filter, please use genuine SANYO DENKI filters. ● Do not water-wash the filter. ● Avoid use and storage under high temperature or humidity, direct sunlight or exposure to ultraviolet light, or in corrosive gas. ● No nuts or screws for use in attachment included.

Applicable models : AC Fan 120×120×38mm

Neither filter kit nor screen kit can be installed on ACDC fans and AC fans with sensor.
Please evaluate it by assembly filter kits on the device.

Dimensions (unit : mm)

Model : 109-018

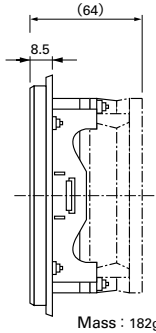
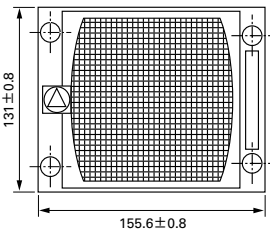

Material
Steel Wire Mesh : Stainless 16-mesh nets in 3 layers
Cover : Resin
Metal fittings : Steel (chromate-plated)
Mass : 182g

Airflow - Static Pressure Characteristics

(by SANYO airflow chamber)

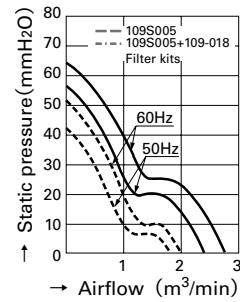

Reference Dimensions Of Mounting Holes (unit : mm)

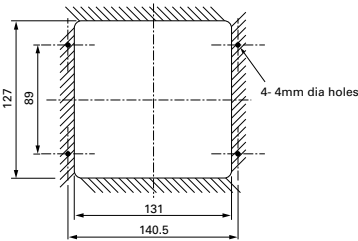

The parts shown in the installation diagram (nuts, washers, and screws) are included.

Mounting Example

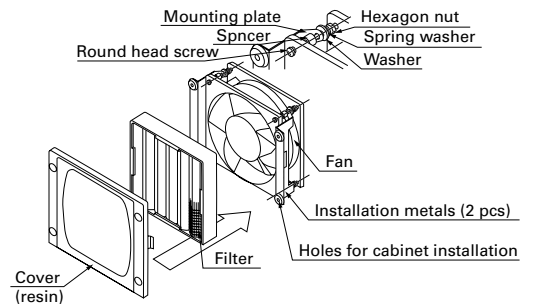

Applicable models : AC Fan 120×120×38mm

Neither filter kit nor screen kit can be installed on ACDC fans and AC fans with sensor.

Dimensions (unit : mm)

Model : 109-020

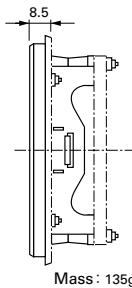
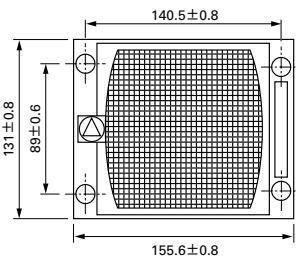

Material
Steel Wire Mesh : Stainless 16-mesh nets in 1 layers
Cover : Resin
Metal fittings : Steel (chromate-plated)
Mass : 135g

Airflow - Static Pressure Characteristics

(by SANYO airflow chamber)

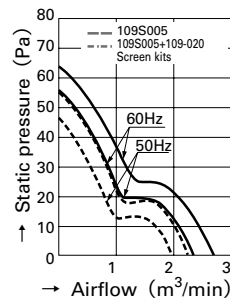

Reference Dimensions Of Mounting Holes (unit : mm)

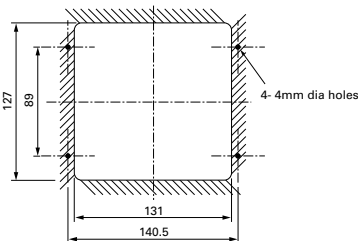

The parts shown in the installation diagram (nuts, washers, and screws) are included.

Mounting Example

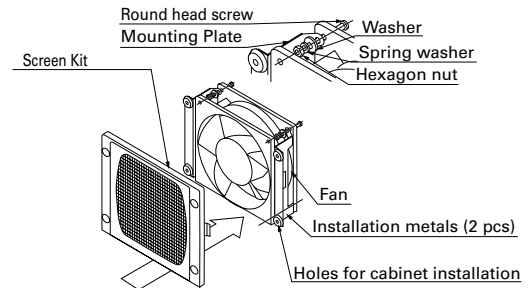

Products Compliant with Electrical Appliance and Material Safety Law (unit : mm)

For 80×80×42mm

Model	Power cord length (L) [mm]	Mass [g]
489-008-L10	1,000	30
489-008-L21	2,100	61
489-008-L35	3,500	99

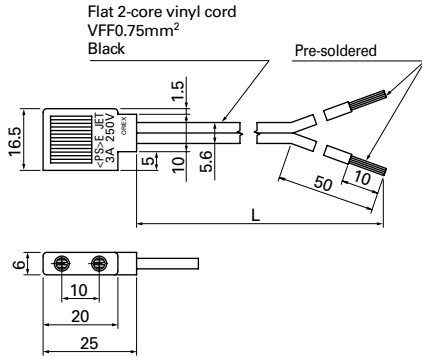

For 80×80×25mm 80×80×38mm 92×92×25mm 120×120×25mm

Model	Power cord length (L) [mm]	Mass [g]
489-016-L10	1,000	34
489-016-L21	2,100	64

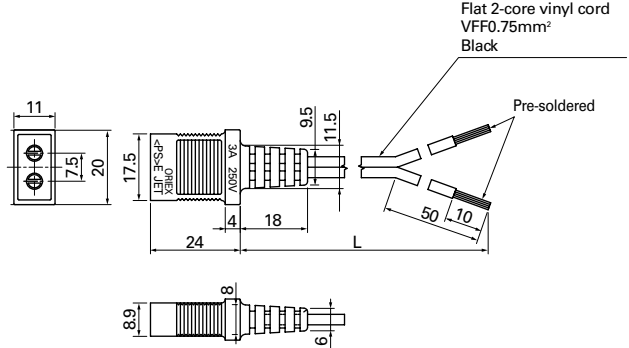

For 120×120×38mm (not including AC/DC fan)

Model	Power cord length (L) [mm]	Mass [g]
489-006-L10	1,000	47
489-006-L21	2,100	76
489-006-L35	3,500	114

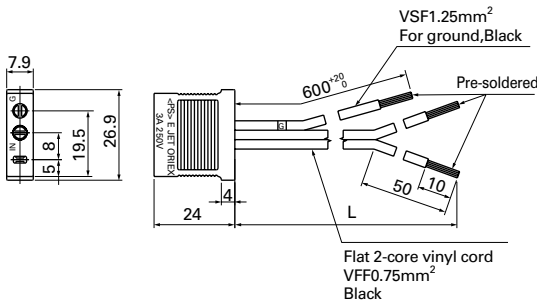

For 120×120×38mm (not including AC/DC fan)

Model	Power cord length (L) [mm]	Mass [g]
489-037-L10	1,000	46
489-037-L21	2,100	76
489-037-L35	3,500	114

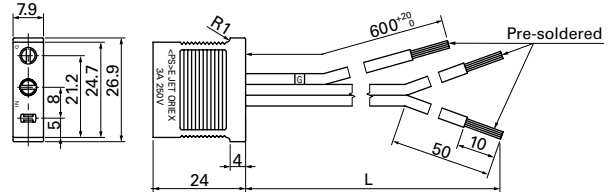

For 160×160×51mm

Model	Power cord length (L) [mm]	Mass [g]
489-1618-L10	1,000	34
489-1618-L21	2,100	63
489-1618-L28	2,800	83

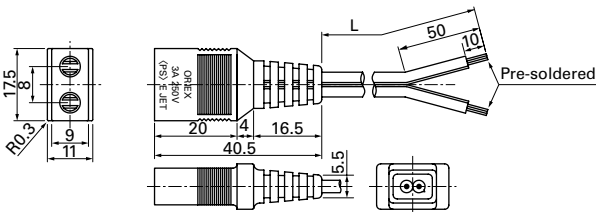

For φ172mm×51mm φ172×150×51mm 160×160×51mm

Model	Power cord length (L) [mm]	Mass [g]
489-1619-L10	1,000	34
489-1619-L21	2,100	64

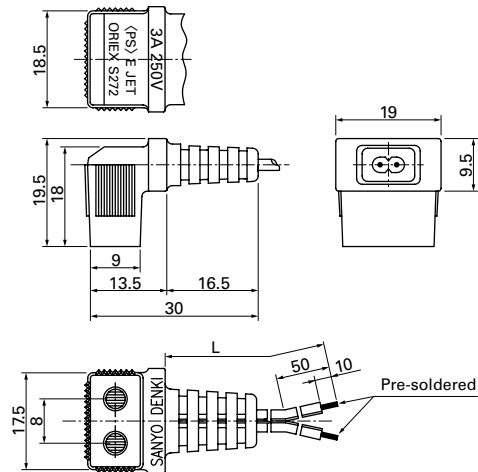

●Be careful not to damage the plug/cord when taking them out of the package.

UL/CSA Certified (unit : mm) **UL FILE No.: E50197** **CSA FILE No.: LR67048**

For 120×120×38mm (not including AC/DC fan)

Model	Power cord length (L) [mm]	Mass [g]
489-007-L10	1,000	48
489-007-L21	2,100	80

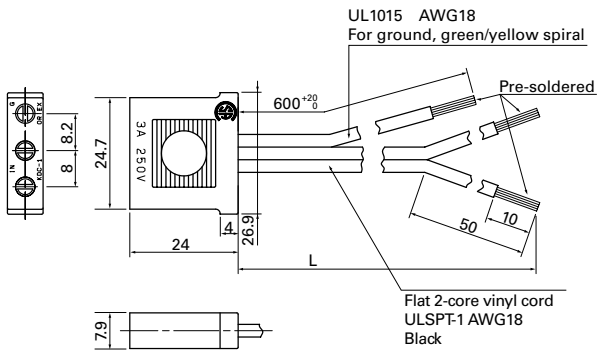

For 80×80×25mm 80×80×38mm 92×92×25mm

Model	Power cord length (L) [mm]	Mass [g]
489-047-L10	1,000	38
489-047-L21	2,100	71

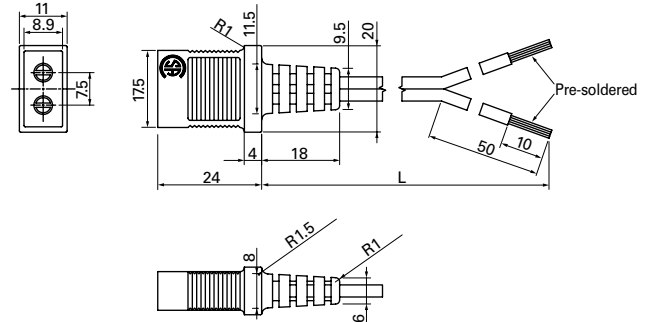

For φ172mm×51mm φ172×150×51mm 160×160×51mm

Model	Power cord length (L) [mm]	Mass [g]
489-084-L10	1,000	37
489-084-L21	2,100	70

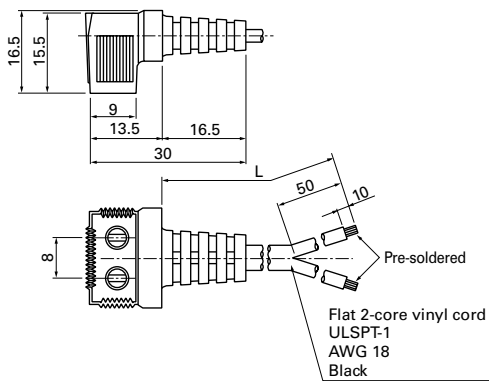

For 160×160×51mm

Model	Power cord length (L) [mm]	Mass [g]
489-086-L10	1,000	37
489-086-L21	2,100	70

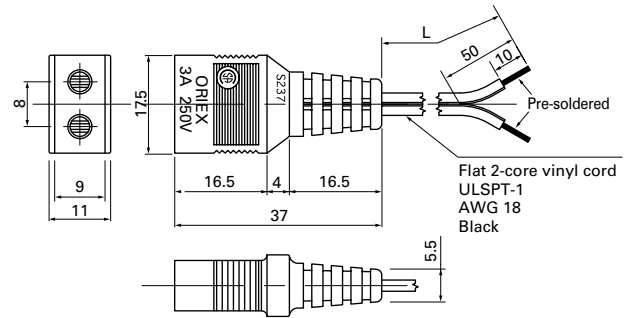

Products compliant with Electrical Appliance and Material Safety Law, UL/CSA [c-UL] Certified (unit : mm) **UL FILE No.E43202**

Model	Power cord length (L) [mm]	Mass [g]
489-1635-L10	1,000	38
489-1635-L21	2,100	74

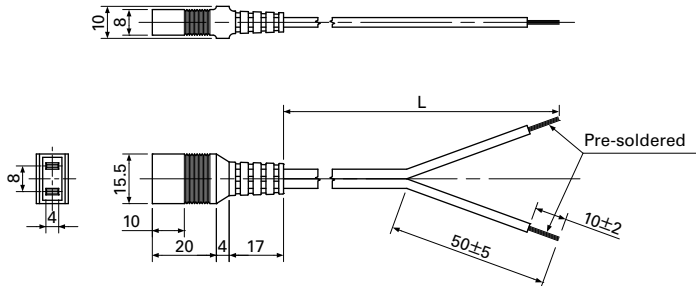

Wiring Harness for Sensor

Model: 489-1636

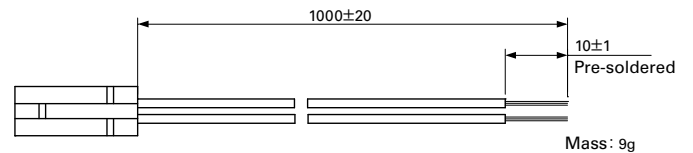

● Be careful not to damage the plug/cord when taking them out of the package.

Recommended connectors for DC fans

DC

Manufacturer	2 pins Housing model number	3 pins Housing model number	4 pins Housing model number	Contact model number
MOLEX	22-01-1022:P/N 5051-02	22-01-1032:P/N 5051-03 22-01-3037:P/N 2695-03RP	22-01-1042:P/N 5051-04	08-70-0064:P/N 5159T
				08-70-0048:P/N 5159PBT
				39-00-0372:P/N 2759T
	43025-0200	—	43025-0400	43030-0001
	51191-0200	51191-0300	51191-0400	43030-0002
50-37-5023:P/N 5264-02	50-37-5033:P/N 5264-03	50-37-5043:P/N 5264-04	43030-0003	
51191-0200	51191-0300	51191-0400	50802-9001	
			08-70-1039:P/N 5263PBT	
50-37-5023:P/N 5264-02	50-37-5033:P/N 5264-03	50-37-5043:P/N 5264-04	39-00-0059:P/N 5556PBT	
39-01-2020:P/N 5557-02R	—	39-01-2040:P/N 5557-04R	39-00-0038:P/N 5556T	
Tyco Electronics	171822-2	171822-3	171822-4	170262-1
	179228-2	179228-3	179228-4	179227-1
Hirose	DF1B-2EP-2.5RC	DF1B-3EP-2.5RC	—	DF1B-2428PCF
	DF3-2EP-2C	DF3-3EP-2C	DF3-4EP-2C	DF3-EP2428PCF
	DF3AA-2EP-2C	DF3AA-3EP-2C	DF3AA-4EP-2C	
Japan Solderless Terminals	EHR-2	EHR-3	EHR-4	SEH-001T-P0.6
	SMP-02V-BC	SMP-03V-BC	SMP-04V-BC	SHF-001T-0.8BS
	SMP-02V-NC	SMP-03V-NC	—	
	H2P-SHF-AA	H3P-SHF-AA	—	
	PHR-2	PHR-3	PHR-4	SPH-002T-P0.5S
	XAP-02V-1	XAP-03V-1	XAP-04V-1	SXA-001T-P0.6
	XMP-02V	XMP-03V	—	
	XHP-2	XHP-3	XHP-4	SXH-001GU-P0.6
	SMR-02V-B	SMR-03V-B	SMR-04V-B	SXH-001T-P0.6
	SMR-02V-N	SMR-03V-N	SMR-04V-N	SYM-001T-P0.6

Recommended tubes and cable ties for DC fan

DC

	Manufacturer	Representative model numbers	Specifications	UL File No.
PVC tube	YAMAICHI CHEMICAL	YET-300H	105°C 300V VW-1	E55011
	IWASE KAGAKU KOGYO	AH-3		E56036
Thermal contraction tube	SUMITOMO ELECTRIC	SUMITUBE® F2 (Z)	125°C 600V VW-1	E48762
	SUMI-PAC	SUMITUBE® F32		
Cable tie	THOMAS & BETTS	TY-23M	UL94V-2	E49405
	PANDUIT	BT1M		E56854
	HellermannTyton	T18R		E64962

Note : The specifications in this table are for reference purposes only. When selecting, please check catalogs of each brand.

Overview and Characteristics of Fan

Overview DC AC

A cooling fan is widely used to extend life of your system by cooling off heat of the system that many electrical components are mounted in a very high density and dissipating heat. Since we SANYO DENKI developed "San Ace" which is the first AC fan in Japan in 1965, we have increased fan motor lineup until now meeting customer's needs rapidly based on our tremendous career. We SANYO DENKI will continue to develop new fans with high airflow, low noise, low vibration, and energy-saving design.

Characteristics DC AC

We can roughly divide fan into two types which are AC and DC.

AC Fans

SANYO DENKI succeeded in the mass-production of AC fans in 1965. SANYO DENKI was the first Japanese manufacturer to have succeeded at this.

- High performance
- High reliability
- Safety

DC Fans

SANYO DENKI succeeded in the mass-production of DC fans in 1982.

- High performance
- Low power consumption
- Low vibration
- Low leakage of flux
- High reliability

SANYO DENKI currently has a wider variety of products like Long Life Fan, CPU cooler, Splash Proof Fan, and Oil Proof Fan etc to meet all customer needs.

Guideline in Selecting a Fan

How to select an appropriate fan DC AC

The following example is a guideline regarding how to select an appropriate fan for cooling your system

1. Determining of your system specifications and conditions

Determine the temperature rise inside your system and obtain the total heating value inside your system on the basis of its inputs and outputs.

Example

- V : Total heating value of your system (W) =100 (W)
- ΔT : Inside temperature rise (K) =15 (K)

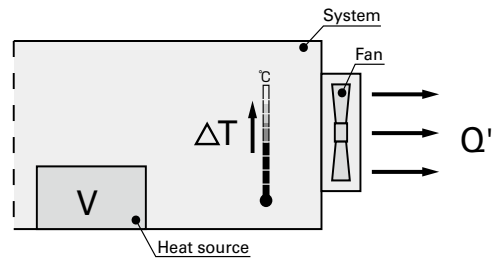

2. Calculating the required airflow for cooling

After the equipment specifications and conditions of your system have been determined, calculate required airflow to meet the conditions. (Note that the formula shown below only applies when the heat radiation is performed only by cooling air from the fan.)

Example

Q': Motion airflow (m³/min)

$$Q' = \frac{V}{20\Delta T} = \frac{100 (W)}{20 \times 15 (K)} \approx 0.33 (m^3/min)$$

3. Selecting the fan

After the motion airflow has been calculated, select an appropriate fan motor based on the value. The motion airflow when the fan motor is actually mounted in your system can be obtained using the airflow-static pressure characteristics curve and system impedance. However, the system impedance cannot be measured without a measuring equipment, so fan with 1.5 to 2 times higher airflow than the actual max airflow should be selected (operating airflow is one-third to two-thirds of maximum airflow).

Example

Q: Maximum airflow (m³/min)

$$Q' = Q \times 2/3$$

$$Q = Q' \times 3/2 = 0.33 \times 3/2 \approx 0.5 (m^3/min)$$

Next, In case that you select a fan having an airflow of 0.5 (m³/min) or more and a appropriate size for the space inside your system.

For example, If you need a fan of 60mm square, 25mm thickness and 12V, you should select is 109R0612H402 (maximum airflow = 0.53m³/min).

4. Confirming the selected fan

Calculate the temperature rise inside your sysetem when your sysetem having 100 (W) of total heating value is forcefully cooled down by a 109R0612H402 fan.

Example

$$Q' = Q \times 2/3 = 0.53 \times 2/3 \approx 0.353 (m^3/min)$$

$$\Delta T = V / 20Q' = 100 (W) / 20 \times 0.353 (m^3/min) \approx 14.2 (K)$$

From the above, the temperature rise inside your system is calculated as 14.2 (K).

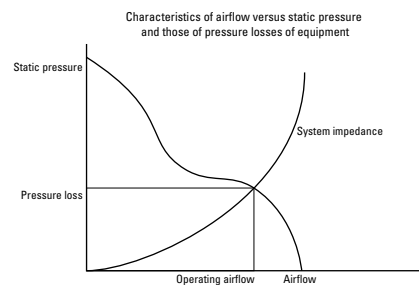

Since the value obtained from the above equation is only a rough target, final fan selection should be based on your actual installation test.

Characteristics Calculation Method and Description

Reliability and expected life

DC AC

A cooling fan generally cools itself as well. The temperature rise of the motor is relatively low and the temperature rise of the grease in the bearings is also low, so expected life is longer than general some either motors. Since the service life of bearings is a theoretical value that applies when they are ideally lubricated, the life of lubricant can be regarded as expected life of the fan. DC fan consumes less power and its temperature rise of bearing is very low. When the measurement conditions are: L10 (the remaining product life in the lifespan test is 90%), with an atmospheric temperature of 60 degrees, at the rated voltage, and continuously run in a free air state. The table below indicates the relationship between ambient temperature and expected life estimated on the basis of our life tests and same other tests conducted by SANYO DENKI.

Expected life of DC Fans

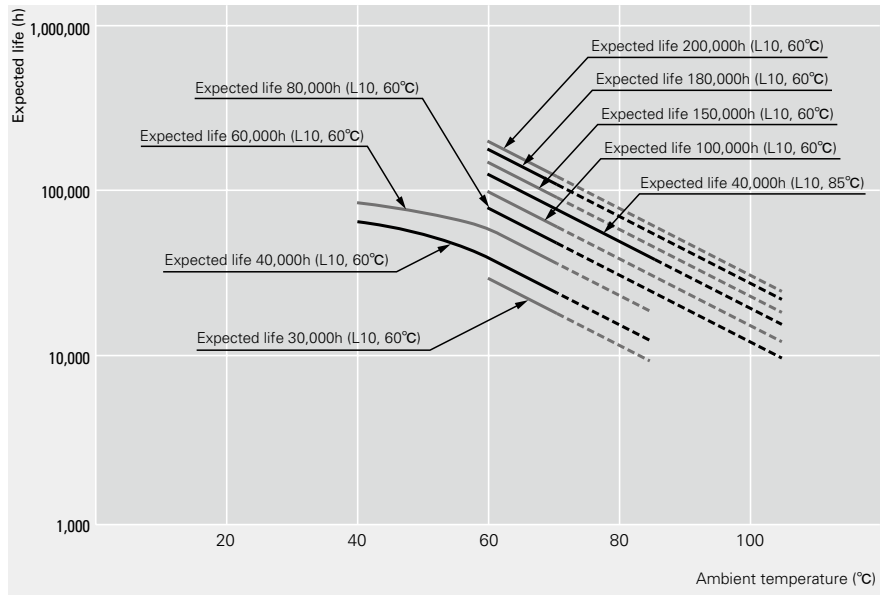

Rated voltage, continuously run in a free air state, survival rate of 90%

Expected life of AC Fans

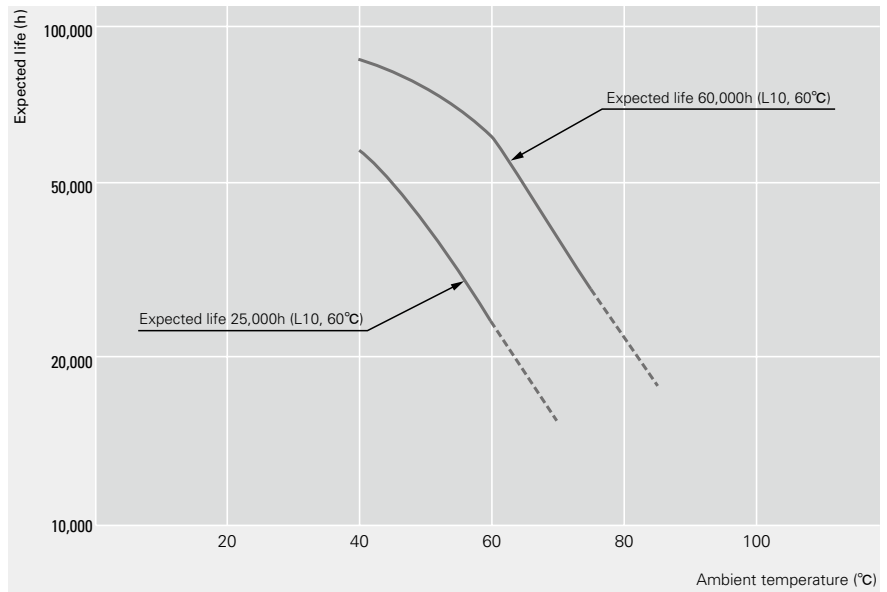

Rated voltage, continuously run in a free air state, survival rate of 90%

Noise characteristics

DC AC

Noise is average value that measured at 1 meter away from air intake side of fan that is suspended on special frame in anechoic chamber (as per JIS B 8346).

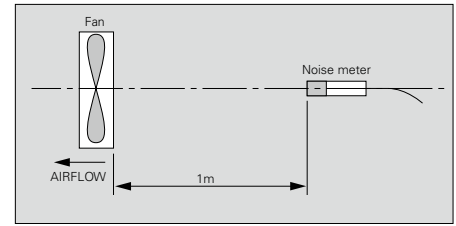

Acoustic radio wave anechoic chamber



Noise characteristic measurement equipment



Measuring airflow and static pressure

DC AC

It is very difficult to measure airflow and static pressure. In fact, the performance curve may vary greatly according to the type of measuring equipment.

The commonly-used type of measuring equipment is a wind tunnel using a Pitot tube. SANYO DENKI uses a very precise method using double chamber equipped with many nozzles.

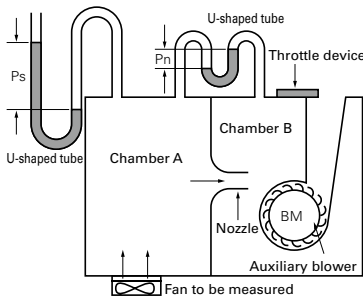

Double chamber measuring equipment

$$Q = 60A\bar{v} \text{ (A)}$$

where

$$Q = \text{airflow (m}^3\text{/min)}$$

$$A = \text{cross sectional area of nozzle} = \frac{\pi}{4}D^2 \text{ (m}^2\text{)}$$

$$D = \text{nozzle diameter}$$

$$\bar{v} = \text{average airflow velocity of nozzle} = \sqrt{2g \frac{P_n}{\gamma}} \text{ (m/s)}$$

$$\gamma = \text{Specific weight of air} = \rho g \text{ (N/m}^3\text{)}$$

(Air density $\rho = 1.2 \text{ kg/m}^3$ at 20°C , 1 atm)

$$g = \text{acceleration of gravity} = 9.8 \text{ (m/s}^2\text{)}$$

$$P_n = \text{differential pressure (Pa)}$$

$$P_s = \text{static pressure (Pa)}$$

The measuring equipment using double chamber is method to be calculated from airflow goes through nozzle and differential pressure between pressure of inside of chamber (P_s) and atmospheric pressure by measuring differential pressure between air intake and exhaust of nozzle (P_n).

Conversion table

DC AC

Static pressure

$$1\text{mm H}_2\text{O} = 0.0394\text{inch H}_2\text{O}$$

$$1\text{mm H}_2\text{O} = 9.8\text{Pa (Pascal)}$$

$$1\text{inch H}_2\text{O} = 25.4\text{mm H}_2\text{O}$$

$$1\text{Pa} = 0.102\text{mm H}_2\text{O}$$

$$1\text{inch H}_2\text{O} = 249\text{Pa}$$

Airflow

$$1\text{m}^3\text{/min} = 35.31\text{ft}^3\text{/min (CFM)}$$

$$1\text{CFM} = 0.0283\text{m}^3\text{/min}$$

$$1\text{m}^3\text{/min} = 16.67 \ell /\text{s}$$

$$1\text{CFM} = 0.472 \ell /\text{s}$$

$$1 \ell /\text{s} = 0.06\text{m}^3\text{/min}$$

Splash Proof Fan

Ingress protection ratings (IP code)

DC

- IP Codes used by SANYO DENKI express the level of protection that internal electrical components (for fans: electrical components and motor coils) have against solid objects, water, and access to hazardous parts. San Ace Splash Proof fans feature high protection levels.



Protected electrical components and motor coils

- Definition of Ingress Protection (IP Code)
Ingress Protection (IP Code) is defined in IEC (International Electrotechnical Commission) 60529* DEGREES OF PROTECTION PROVIDED BY ENCLOSURES (IP Code). *IEC 60529:2001

I P X X

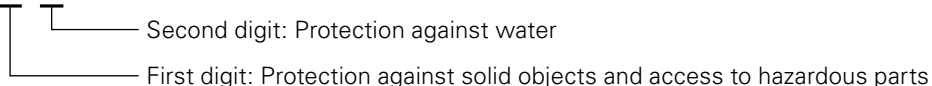

First digit	Definition
0	No protection
1	Protection against solid objects > 50 mm
2	Protection against solid objects > 12.5 mm
3	Protection against solid objects > 2.5 mm
4	Protection against solid objects > 1 mm
5	Protection against a level of dust that could hinder operation or impair safety
6	Complete protection against dust

Second digit	Definition
0	No protection
1	Protection against dripping water
2	Protection against water spray up to 15°
3	Protection against spraying water
4	Protection against splashing water
5	Protection against low pressure water jets
6	Protection against high pressure water jets
7	Protection against temporary immersion in water
8	Protection against submersion in water

UPS, inverter, rectifier, high-voltage power supply, etc.

Cautions for Use of a Cooling Fan in the Vicinity of a Power Switching Circuit (prevention of electrolytic corrosion)

If a fan is installed near a large-power or high-voltage switching circuit, the heavy electromagnetic noise resulting from electromagnetic induction in such circuits or the influence of high-frequency noise imposed through the power line of the fan may induce current through the shaft bearing of the fan. Such current may damage the oil film on the bearing and even the friction surface of the bearing. This adverse effect is known as "electrolytic corrosion of the fan." Electrolytic corrosion affects the smooth revolution of the fan and may reduce its service life. An audible symptom is unusual noise emitted from the fan. This adverse effect is often observed and may partly be explained by the practice of mounting high-density parts, which reduces the gap between the switching circuits and the fan and the use of higher switching frequencies apt to provoke induction. Data processing/communications devices that operate at low voltages are not liable to electrolytic corrosion since they generate less electromagnetic noise.

A Case of electrolytic corrosion DC AC

Fans without anti-corrosion features installed near components that generate electromagnetic noise, such as inverter controllers, are liable to experience electrolytic corrosion.

No.	Use	Period until the occurrence of unusual noise
1	Switching power supply	6 months to 2 years
2	UPS	6 months to 2 years
3	General-purpose inverter	1 to 1.5 years
4	Air cleaner	2 to 3 months
5	Inverter for LCDs	6 months

The curve shown in the graph below represents the relationship between the level of the electromagnetic noise induced by a fan and the distance from the fan to the noise source.

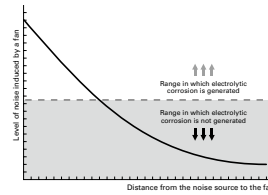

Occurrence of electrolytic corrosion Pattern 1

- (1)The fan gets charged with high-frequency electricity by high-frequency noise (electric field/magnetic field) generated in the switching circuit.
- (2)Because of high-frequency electricity charged in the fan, an electric current flows through the bearing of the fan.
- (3)The electric current breaks the oil membrane on the surface of the bearing and the bearing gets abraded (electrolytically corroded).
- (4)This symptom often occurs in equipment in which switching circuits are sped up and implemented in high density.
- (5)Countermeasure 1: To provide a shield plate^(Note 1) inside the fan (The plate should be such that does not interfere with airflow).
- (6)Countermeasure 2: To use a fan with ceramic bearings.

Occurrence of electrolytic corrosion Pattern 2

- (1)High-frequency electricity flows from the circuit board into the inside of the fan superimposed with the power line for the fan.
- (2)High-frequency electricity that has entered into the fan flows through the bearing.
- (3)Oil membrane on the surface of the bearing gets broken and the bearing gets abraded (electrolytically corroded).
- (4)Countermeasure 1: To remove high-frequency component between terminals "a" and "b", "a" and "e" and "b" and "e" of the power supply for the fan, or to insert a filter^(Note 2) into the power line for the fan.
- (5)Countermeasure 2: To use a fan with ceramic bearings
- (6)Cables should be twisted in order to decrease induction to the power line for the fan.

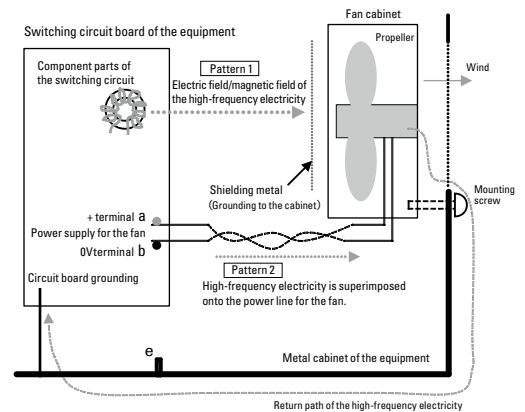

Note 1 : Shielding metal plate
 As an electromagnetic shield metal, "EMC Guard" is available from our company. <http://www.sanyodenki.co.jp/product/newfan/indexf.html>
 Certain shielding effect can be expected from mounting a general-purpose finger guard inside the fan. In each case, grounding to the cabinet is required.

Note 2 : Filter
 Insert a common mode filter when the high-frequency electricity is superimposed on both lines "a" and "b" in the same phase and, if not, insert a normal mode filter.

Measures against electrolytic corrosion DC AC

- Relocate fans far from all electromagnetic noise sources.
- Attach an EMC guard to ordinary fans. This should have an effect on electromagnetic noise due to radiation.
- As a power supply, the fan is wired from a circuit for which noise is not superimposed.
- Against heavy electromagnetic noise (electromagnetic induction) and conductive noise from the power supply line for a fan, we recommend the use of an "Electrolytic corrosion proof fan" with ceramic bearing.

This cooling fan prevents electrolytic corrosion of bearings even under conditions where electromagnetic noise is generated. Electrolytic corrosion of ball bearings is prevented by using ceramic balls in ball bearings. The ceramic material is an insulating material. Manufacturable to meet specifications of all San Ace series fans.

Component Diagram

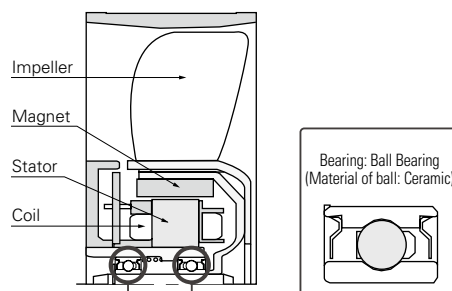

Caution

Electrolytic Corrosion Proof Fan has been designed to prevent the electrolytic corrosion of ball bearings in the fan, but this does not guarantee that the fan will operate normally under conditions where there is strong electromagnetic noise. Please be sure to fully evaluate the value of fan malfunction due to noise in advance.

Specifications for DC Fan Sensors

Pulse sensor (Tach output type) example DC

Pulse sensor outputs two pulse waves per revolution of fan, and it is good to detect fan speed. Pulse sensors can be incorporated in all kinds of DC fans.

* Noise from inside the fan or from external devices may effect sensor output.
Contact us for more information.

The specifications listed below are for the 9G1212H101 model, and vary with the model number used. Please contact your point of sale for details.

Output circuit
Open collector

Specifications

$V_{CE} = +30V$ MAX.
(For a 48V-rated fan: $V_{CE} = +60V$ MAX.)
 $I_c = 10mA$ MAX. [$V_{OL} = V_{CE} (SAT) = 0.4V$ or less]

Inside of DC fan

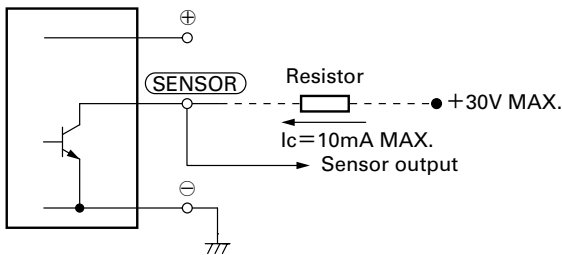

Output waveform (Need pull-up resistor)
In case of steady running

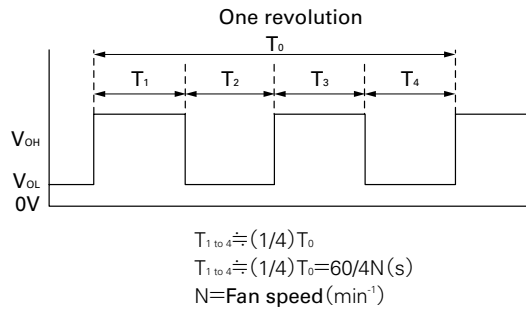

* If you want detailed specifications that apply when the rotor is locked, please contact SANYO DENKI.

Locked rotor sensor (rotation/lock detection type) example DC

Locked rotor sensor outputs fan status signals. It is good to check whether the fan is running or locked

- * Noise from inside the fan or from external devices may effect sensor output.
- * Regarding details of the reverse logic and specifications of lock sensor output signals, please contact SANYO DENKI.
- * Lock sensor can not be used in some models. Contact us for more information.

The specifications listed below are for the 9G1212H1D01 model, and vary with the model number used. Please contact your point of sale for details.

Output circuit
Open collector

Specifications

$V_{CE} = +27.6V$ MAX.
For a 48V fan $V_{CE} = +60V$ MAX.
 $I_c = 5mA$ MAX. [$V_{OL} = V_{CE} (SAT) = 0.6V$ or less]
For a 48V fan: $V_{CE} (SAT) = 0.4V$ or less

Inside of DC fan

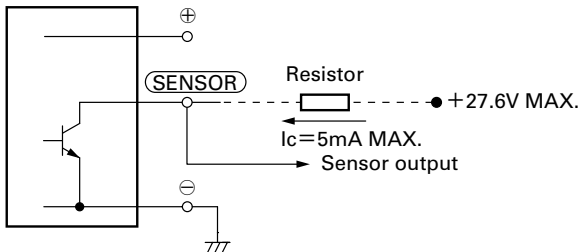

Output waveform (Need pull-up resistor)

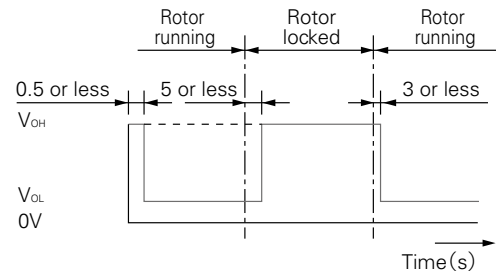

Note: The output is completely at V_{OL} with 0.5s or less after power-up.

Low-speed sensor outputs a signal when fan speed goes down to trip point or less. It is good to detect cooling degradation of fan.

- *Noise from inside the fan or from external devices may effect sensor output, please.
- *If you want detailed specification and reverse signal output, please contact SANYO DENKI.
- *Low-speed sensors can not be used in some models. Contact us for more information.

The specifications listed below are for the 9G1212H1H01 model, and vary with the model number used. Please contact your point of sale for details.

Output circuit

Open collector

Specifications

$V_{CE} = 27.6V \text{ MAX.}$
 $I_c = 10mA \text{ MAX.}$ [$V_{OL} = V_{CE}(\text{SAT}) = 0.5V \text{ or less}$]

Sensor scheme

Example 1: In case steady running

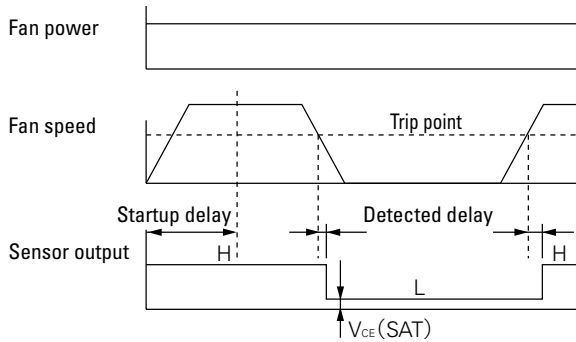

Inside of DC fan

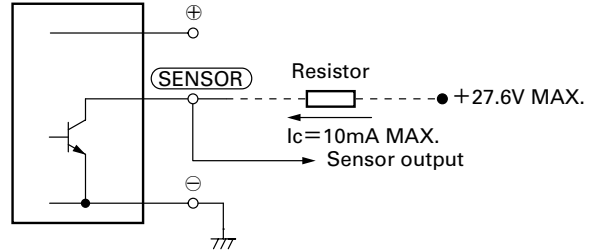

Example 2: In case that the rotor is locked when the fan motor is turned on and released after the start-up delay time.

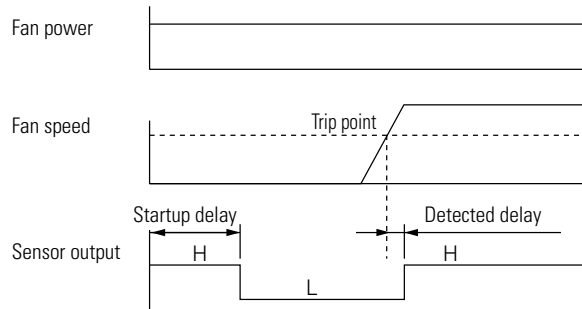

Specifications for AC Fan Sensor

ACDC fan sensor specifications differ from those below. Please refer to each product page.

Specifications of sensor circuit

	5V (ITEM-20*)	12V (ITEM-30*)
Example of model.no	109S405UL	
System	Speed detection, Auto-restart, Open collector	
Power supply	DC5V±10% At 5V, 6mA	DC12V±20% At 12V, 10mA
Recommend sensor circuit output	At $V_p = 5V, I = 100mA \text{ MAX.}$	
Trip point	Standard speed : $1,700\text{min}^{-1} \pm 10\%$ Low speed : $850\text{min}^{-1} \pm 10\%$	
Response speed	Standard speed : Startup delay 18s Detection delay 1s Low speed : Startup delay 36s Detection delay 2s	
Insulation resistance	10 MΩ MIN. at a 500V DC megger (Note)	
Dielectric strength	50/60 Hz, 1,000V AC, 1 minute (Note)	
Ambient conditions	Temperature: $-10 \text{ to } +60^\circ\text{C}$, humidity: 90%RH MAX. (at 40°C)	



*[ITEM-20] and [ITEM-30] are printed on the fan nameplate.

Note: Between one end that all sensor leads consisting of brown, yellow and black are tied together and the G terminal or power terminal of the fan.

Sensor scheme

Example 1: When the AC power for the fan and the DC power for the sensor are turned on at the same time

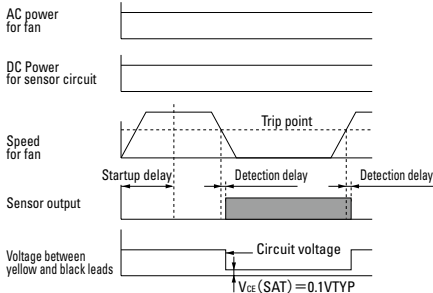

Example 2: When the AC power for the fan is turned on first, then the DC power for sensor is powered on

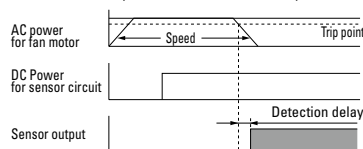

Example 3: When the DC power for sensor is first powered on, then the AC power for the fan is turned on

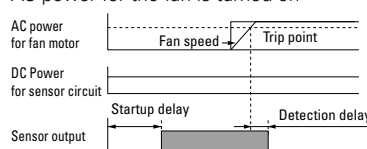

Sensor output circuit

5V (ITEM-20*)

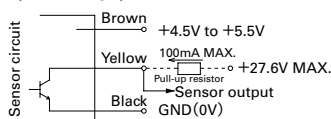

12V (ITEM-30*)

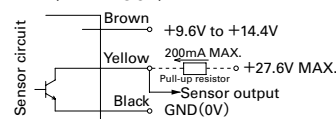

GND (Black) should be shared in case that power supply for sensor circuit (Brown) and that for sensor pull-up (Yellow) are separated.

Fans with PWM Control Function

PWM control function DC

1. Overview

Pulse Width Modulation (PWM) control function enables you to externally control the speed of the fan by varying the duty cycles of PWM input signals between control and grounding terminals. It allows fans to operate optimally in response to the device's heat level, lowering the noise and power consumption of the system.

PWM control function has the following advantages:

- (1) Because the PWM signal is digitally input, precise control is possible.
- (2) Because the PWM signal is digitally input, multiple fans can be controlled.
- (3) Upon users request, how the fan speed responds to PWM signals can be customized. For example, fan can be set to stop or run at low speed at 0% PWM duty cycle.

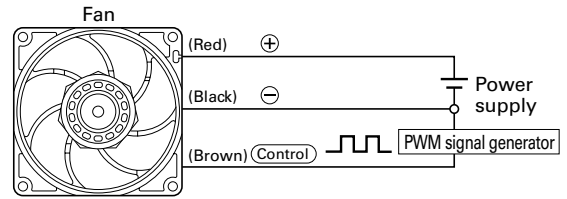

2. PWM duty input signals and wiring diagram

Other than a TTL input, an open collector/drain input can be used for PWM signal input.

Be noted that if an open collector/drain input is used or applied an input voltage and frequency is out of specified range, how the fan speed responds to the PWM duty cycle may be altered.

The input signal voltage and the frequency differ with models. Please contact us for details.

Example of input signal (TTL input)

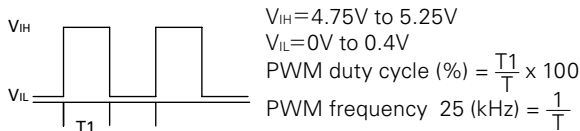

Current source (I_{source}) = 1 mA max. (when control voltage is 0 V)
 Current sink (I_{sink}) = 1 mA max. (when control voltage is 5.25 V)
 Control terminal voltage = 5.25 V max. (when control terminal is open)
 When the control terminal is open, fan speed is the same as when PWM duty cycle is 100%.

Wiring example

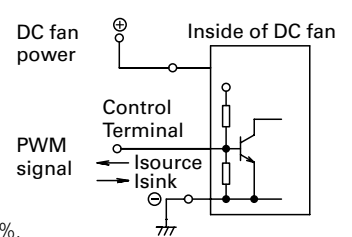

3. PWM duty cycle – Speed characteristics

Fan speed of PWM control fans change, as the below performance curve shows, in response to the PWM duty cycle input.

If necessary, users can do the speed setting by themselves, making the fans operate at the optimum speed.

Also, upon user's request, how fan speed responds to a PWM signal can be customized so that the fan stops or runs at low speed for a certain PWM duty cycle input. The below performance curve is for a fan that stops at 0% PWM duty cycle. Specifications differ with models. Please contact us for details.

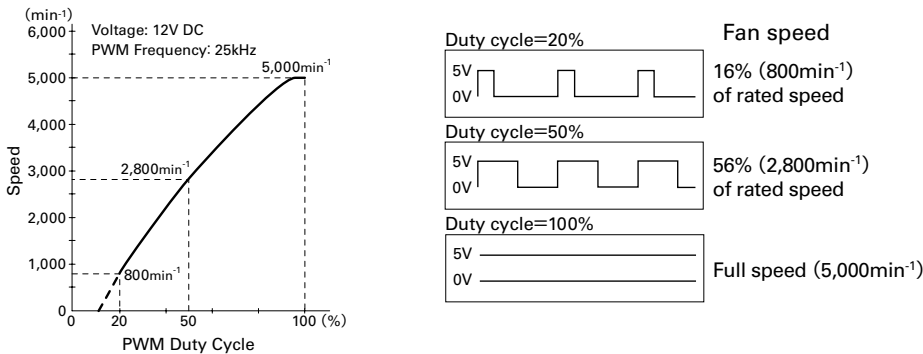

The dotted part of the performance curve (area below 20% PWM duty cycle in the above case) indicates the fan speed is unstable in the area.

4. When you wish to obtain a fan performance with 100 or 0% PWM duty cycle without a PWM signal generator for built-in test.

Performance at 100% PWM duty cycle: Leave the control lead wire open and no connection.

Performance at 0% PWM duty cycle: Connect the control lead wire directly to ⊖ pin.

5. Application examples of PWM control fan

Here are a few application examples of PWM control fan.

- (1) This system controls the fan speed in response to changing device temperature.

By combining a PWM control circuit and thermistor that detects temperature of device and its parts, it is able to control the fan speed of PWM control fan in response to the changing temperature.

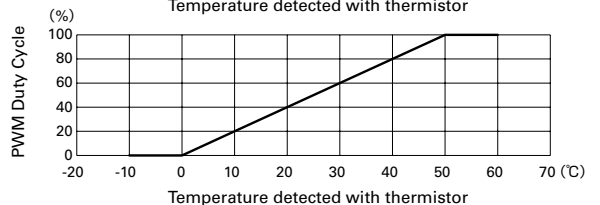
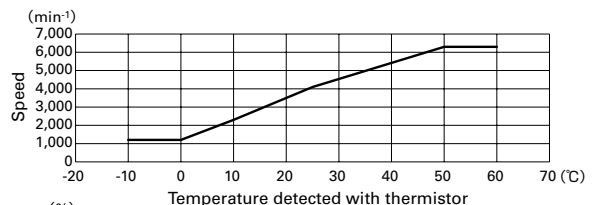
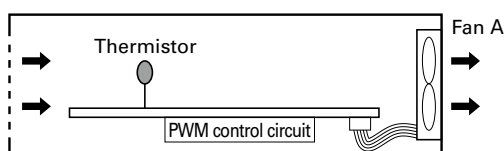

(2) Simultaneous control of multiple fans

Because PWM control is done with digital signal inputs, regardless of fan types or input voltage, multiple fans can be controlled simultaneously.

Below figure shows a system that can control multiple fans with various PWM characteristics simultaneously. Such systems contribute to the low power consumption and noise.

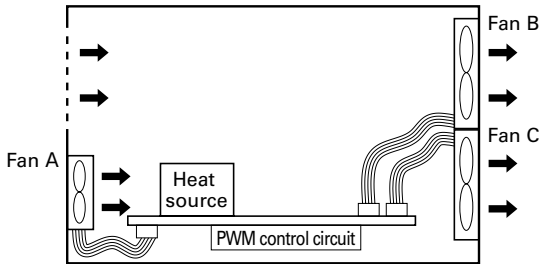

Operation mode	PWM Duty	Fan A	Fan B, C
Full-power	100%	5,000min ⁻¹	5,000min ⁻¹
Normal	60%	3,500min ⁻¹	4,000min ⁻¹
Standby (eco mode)	0%	Stop	1,500min ⁻¹

Fan A (model that stops at 0% PWM duty cycle)

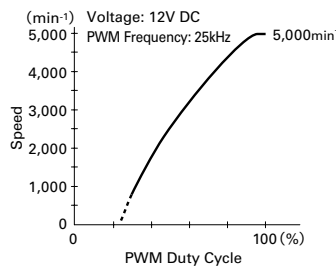

Fan B, C (model that runs at low speed at 0% PWM duty cycle)

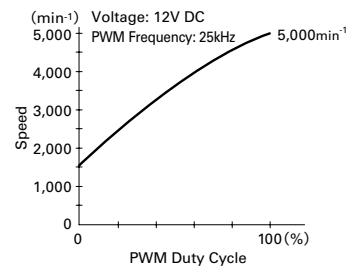

Controlling device that easily regulates the rotational speed of PWM control fans function

DC

San Ace PWM Controller

■Features

Reduces system power consumption and fan noise

For PWM fan speed control, a PWM control circuit needs to be newly designed and configured.

By using this product, however, PWM control function fans can be fully utilized without the need for preparing new circuits, contributing to reducing the system power consumption and the fan noise.

Can be common-powered by the fan power supply

The controller can be powered by the fan power supply of rated voltage 12, 24, and 48 VDC, and no separate supply is required.

Maximum of four fans connectable

Up to four fans with PWM control function can be connected and controlled. Please refer to page 457 for detail.

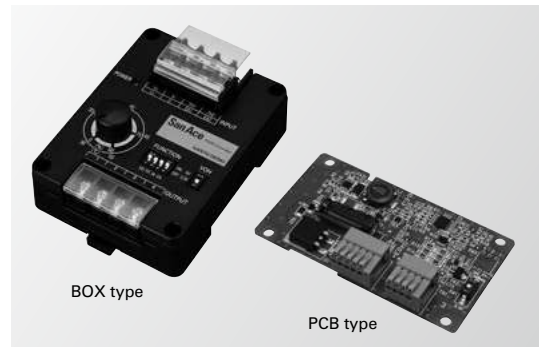

Operating Precautions DC AC

Temperature conditions

Operating temperature: Refer to the specifications table for each model.

Storage temperature: -20°C to $+70^{\circ}\text{C}$ / -30°C to $+70^{\circ}\text{C}$ (Varies for each model / Non condensing)

* Rapid change in temperature may cause condensation. Prevent condensation when storing. Condensation may affect lubrication performance and insulation.

Power specifications

For the specification of rated voltage and voltage range, please check the catalog or drawing for the model number.

Use of voltage exceeding the specified range may lead to performance degradation, device failure, or fire hazards. Do not apply voltage that exceeds specifications to the fan.

An electronic circuit is used for the DC fan. For power supply, use power with ripple less than 5% with low line noise and surge to prevent electronic circuit trouble.

Handling precautions

The fan motor is equipped with a precision ball bearing. Therefore, please handle the motors carefully in order not to shock the bearings.

Installation tips

There are no limitations on the installation direction of fans or blowers. Fans have symbols on the fan indicating the airflow direction and blade rotation direction. When installing, use these symbols to check the airflow direction.

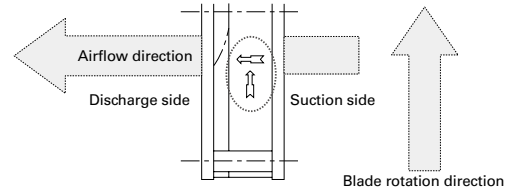

Symbols indicating the fan airflow direction and blade rotation direction

Recommended screw torque

This shows the recommended values for the screw torque when installing the fans. If the tightening torque is higher than the recommended values, the fan can be deformed or damaged.

Use care when tightening. Also, be sure to always use a fan with a ribbed structure when securing by screws with both flanges.

DC fan

Fan mounting hole diameter [mm]	Nominal screw diameter	Recommended screw torque
$\phi 3.5$	M3	0.44N·m MAX.
$\phi 4.3$, $\phi 4.5$	M4	0.78N·m MAX.
$\phi 4.3$, $\phi 4.5$	M4	0.98N·m MAX. ($\phi 172\text{mm} \times 51\text{mm}$, $\phi 172\text{mm} \times 150\text{mm} \times 51\text{mm}$, $\phi 200 \times 70\text{mm}$)

AC fan

Fan mounting hole diameter [mm]	Nominal screw diameter	Recommended screw torque
$\phi 3.5$, $\phi 3.7$	M3	0.44N·m MAX.
$\phi 4.3$	M4	0.58N·m MAX. (120mm×120mm MAX.)
$\phi 4.3$	M4	0.78N·m MAX. (ACDC fan, $\phi 172\text{mm}$)
$\phi 5.5$	M4, M5	0.78N·m MAX. (160mm×160mm)

Comparison of ribbed and ribless structures

Regarding plastic frame, we have a option ribbed and ribless about mounting. Please use preferred type up to your application. Please use ribbed fan in case that you hook fan up clamping either side fan mounting hole target. (According to the model, only models with or without ribs are available.)

*Use a fan with a rib structure when securing by screws with both flanges.

· When securing screws to ribless plastic frame models, use a flange to secure on one side.

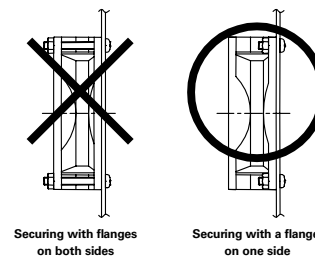
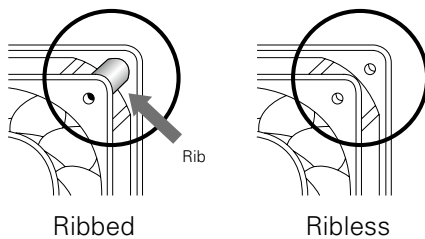

Fan Mounting Using Self-tapping Screw DC

Installing self-tapping screws into the plastic frame of the fan may split or deform it.

If using self-tapping screws, use screws that are recommended by our company, and refer to our recommended tightening torques and recommended pilot hole shapes. Pay close attention to the operating precautions and fully understand your equipment before you use it.

Recommended screw torques

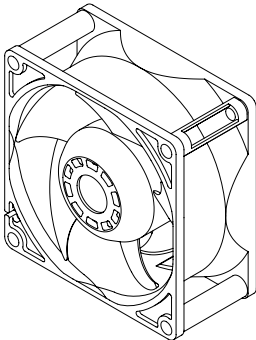

Fig. A: Ribbed fan

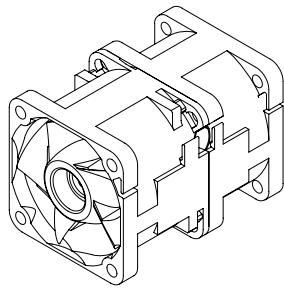

Fig. B: Counter rotating fan

	Recommended screw torque [N·m]	Fan mounting hole diameter [mm]
Ribbed fan (Fig. A)	0.8 Max.	φ3.5, φ4.3, φ4.5
Counter rotating fan (Fig. B)	0.6 Max.	

Do not use self-tapping screws in the following cases:

- For ribless fans (except for counter rotating fans)
- When mounting finger guards on fans

Using self-tapping screws could deform or split the frame. Please use regular screws.

Recommended pilot hole shape

[For nominal diameter 4mm]

Self-tapping screw model No.
SY-NS020412P11

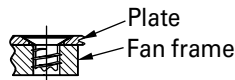
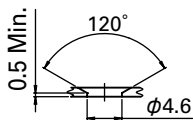

Minimum mounting plate thickness: T=1.2mm

Self-tapping screw model No.
SY-NS010412P11

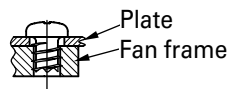
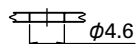

[For nominal diameters of 4.8mm and 5mm]

Self-tapping screw model No.
SY-NS024812P15
SY-NS020512P15

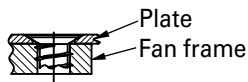
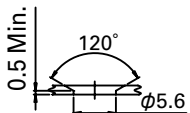

Minimum mounting plate thickness: T=1.2mm

Self-tapping screw model No.
SY-NS014812P15
SY-NS010512P15

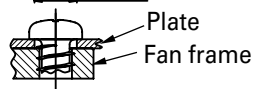
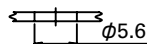

Recommended self-tapping screws

· Material: Steel

· Plating: Trivalent chromating plating

unit : mm

Fan mounting hole diameter	Self-tapping screw model No.	Nominal screw diameter	Length [L]	Head shape	Flat-head/pan-head dimensions		
					Head diameter [D]	Height of head [H]	Cross recess No.
φ3.5	SY-NS020412P11	4	12	Flat	6.2	1.1 Max.	2
	SY-NS010412P11	4	12	Pan	5.5	2.0	2
φ4.3	SY-NS024812P15	4.8	12	Flat	6.8	1.2 Max.	2
	SY-NS014812P15	4.8	12	Pan	7.0	2.6	2
φ4.5	SY-NS020512P15	5	12	Flat	6.8	1.2 Max.	2
	SY-NS010512P15	5	12	Pan	7.0	2.6	2

Head shape: Flat

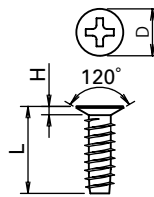

Head shape: Pan

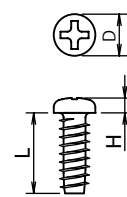

Operating precautions

- Place the self-tapping screw so that it is vertical and centered with the frame mounting hole (Fig. A) and then screw it in. The self-tapping screw could deform or split the frame if you screw it into the frame when the screw is not vertical.
- Screw in the self-tapping screw with the center of the mounting hole on the fan and the center of the pilot hole on the mounting plate aligned (Fig. B). Misaligned holes could lead to the frame being deformed or split.

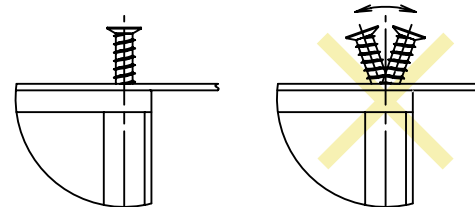

Vertically placed screw

Inclined screw

Fig. A

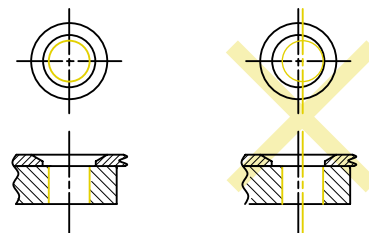

Aligned and centered holes

Misaligned holes

Fig. B

- Tightening the screw beyond the recommended screw torque could deform or split the frame.
- With flat-head screws, failure to use the recommended pilot hole shape will cause interference between the flat-head screw and fan frame which could split the frame.

Recommended screw manufacturer

To purchase the screws, please contact the screw manufacturer directly.

SAIMA CORPORATION

2-9-17 Tsujido Fujisawa Kanagawa 251-0047 JAPAN



TEL:+81-466-36-3656 FAX:+81-466-36-0009

<http://www.saima.co.jp/English/>

Safety Precautions DC AC

- In order to ensure that this product is used safely, be sure that you read and understand the following precautions fully and use the product only as directed.
- Be sure to read these Safety Precautions carefully before installing, connecting, operating, maintaining, or inspecting this product. Follow all the precautions and directions given here.
- This product has been designed and manufactured for use as a device to be used in general industrial machinery, and may not be used as a standalone product.
- The product of our company (hereafter called the product) falls into the category of the products specified in the Attached List 1, Item 16 (Class 84, Item 14) of the Export Trade Control Ordinance. To export the product as an individual part or to export a product into which the product is assembled, the "Information Requirements" and "Objective Requirements" that the Ministry of Economy, Trade and Industry established based on the "Catchall Controls" must be studied for applicability. Based on information on applicability and specified requirements, appropriate export formalities must be performed.

In order to prevent any possible bodily injury or damage to property or equipment, the following precautions for ensuring safety are displayed according to the following two ranks of importance:

 Danger	Handling or using the product improperly and in disregard of the instructions with this mark might result in serious bodily injury or death.
 Warning	Handling or using the product improperly and in disregard of the instructions with this mark might result in bodily injury or physical damage.

※ Note: Items marked 'Warning' might also result in serious bodily injury or death in some circumstances. Always follow the instructions for items marked 'Danger'.

Descriptions of the precautions to be taken to ensure safety are given below.

Danger

- If the product is used in medical appliances or other types of equipment that affect people's lives, sufficient safety-related evaluations and preparations must be made in advance, and the product or the type of equipment into which the product is assembled must be used on the user's own responsibility.
- If the product is used in types of equipment that have a strong social and public impact, sufficient prior evaluations and safety-related evaluations and preparations must be made, and the product or the type of equipment into which the product is assembled must be used on the user's own responsibility.
- If the product is used in an environment where there are vibrations, for example, in a car or aboard a ship, sufficient prior evaluations and safety-related evaluations and preparations must be made, and the product or the piece of equipment into which the product is assembled must be used on the user's own responsibility.
- Connect all wires properly and securely. Failure to do so might result in burns, fire, or exposure to electrical shock.
- If there are any grounding taps or wires, attach all grounds securely. Failure to do so might result in exposure to electrical shock.
- Never use in explosive atmosphere, as doing so might result in fires, burns, or bodily injury.
- Never operate with any live wires exposed, as doing so might result in electrical shock.
- Never allow any persons or objects to approach or come into contact with the rotor while in operation, as doing so might result in damage or personal injury.
- Turn off the power and stop using the product immediately if you notice any sparks, smoke, odd odors, sounds, or anything unusual during operation. Failure to do so might result in fire, burns, or electrical shock.
- Never allow the product to fall, topple over, or otherwise be subjected to excessive shocks when moving it, as doing so might result in product breakdown or substandard operation.
- The product should be handled only by personnel with sufficient training and knowledge and under the responsibility of the end user.
- Never attempt to disassemble, repair, or alter this product in any way, as doing so might result in fire, burns, or electrical shock.
- Dispose of the product as industrial waste. Please contact your local government office for further details about disposal.

Warning

Handling

- Installation, placement, connections, wiring, or relocation of the product should be performed by knowledgeable or correctly licensed personnel. Never perform such work while the product is live as this might lead to injury, electrical shock, burns, or fire.
- Do not use the fan if not fixed or stand in hand.
- Never allow yourself to come into contact with the ends of wires or plugs when measuring the insulation resistance or dielectric strength voltage. This might result in electrical shock.
- Never attempt to disassemble or alter this product in any way. Doing so might invalidate any warranties concerning the functions or performance of the product, and might also result in fire, burns, bodily injury, or electrical shock.

Instruction

- If the fan stops during operation, give proper consideration to the device for its protection.
- Never use the product at voltages, temperatures, or any other settings which exceed those given in the product specifications. This might result in substandard operation, breakdown, fire, bodily injury, or electrical shock.
- The fan may fail to operate properly if there is insufficient power capacity, because the starting current is several times larger than the rated current will flow at the moment of the voltage is supplied to the fan. Be sure to inquire about startup current levels for individual models.
- Do not control the speed of the fan by power supply PWM. It may cause fan failure.
- Start up all fans at the same possible timing if two or more fans which wind interferes with each other are installed in the device.
If the fan is exposed to wind from other fans at start up, it may cause fan failure or the fan may not start up correctly.
- Never insert or remove any lead wires, plug cord or connectors while the power is turned on. When inserting or removing plugs or connections, always be sure to first check that the power has been turned off and hold the housing of the plug or connector when doing so. Failure to do so might result in damage or exposure to electrical shock.
- Do not remove the lead wire from the frame hook. It may scratch and damage the surface of the lead wire.
- Never remove the product identification plate. This might result in breakdown or electrical shock.
- Do not push the nameplate of the DC fan with strong force. The nameplate may break and touch the shaft.
- The product might become damaged if foreign objects or external forces are allowed to interfere with normal fan operation.
- Do not implement ON-OFF of power supply in negative line. That might cause damage of the fan.

Warning

Installation

- When fixing this product into place, be sure to take into consideration the product's weight, the vibrations generated during operation, and all other relevant factors. Failure to do so might cause the product or parts of it to fall out of position, resulting in bodily injury or malfunction of the product.
- Be sure to check the direction of installation (i.e., the fan), as failing to do so might result in bodily injury or mechanical breakdown.
- In order to ensure that the product operates properly, allow spaces for ventilation and take whatever steps necessary to prevent the entry of foreign objects. Failure to do so might result in bodily injury or mechanical breakdown.
- When fixing the fan with screws, make sure the screw and sheet metal do not deform the frame of the fan before operation. If the frame of the fan is deformed, mechanical failure may be occurred or specified performance may not be generated.
- When fixing the fan with screws, ensure the screwing torque. If the screwing torque is over the recommended screw torque, fan frame may be deformed or damaged. Use a plastic frame with a ribbed structure when securing by screws with both flanges. In order to prevent from loosening screw, please use plain washer and spring lock washer. For screwing torque of each fan type, contact SANYO DENKI or SANYO DENKI distributor.
- When fixing the fan with self-tapping screws, fan frame may be damaged.
- When excessive shock is attached to fan, impeller may be protruded from the surface of fan frame. Make sure that impeller does not touch cover such as finger guard and mounting plate. Do not give excessive shock to fan to avoid fan failure and deteriorate of fan performance.
- Pulling or pinching the lead wires could result in damage to the wire, and you should avoid placing excessive stresses on these wires. The device should also be installed so that the lead wires are not allowed to come into contact with the rotor or blades. Failure to do so might result in damage or exposure to electrical shock.
- Take proper precautions against static electricity when making electrical connections. Failure to do so might cause the breakdown of the fan or device.
- Install a finger guard or other cover if there is any danger of fingers, hands or objects coming into contact with the rotor or blades. Failure to do so might result in bodily injury or mechanical breakdown.
- Install the finger guard, filter, and plate to the fan in the correct position while avoiding touching of the rotor blade. Avoiding this will prevent device failure. Please use SANYO DENKI genuine finger guards and filter kits.
- Make electrical connections properly. If not, there is a possibility that breakdown of device, malfunction, breakdown and deterioration of product might cause.

Installation of Centrifugal Fan

- The fan shall be fixed with screws. For screw size of each fan type, refer to drawing or catalog.
- Do not use the screws with length over the depth of mounting screw. Fan might not be fixed by damaging threaded hole. For depth of mounting screw of each fan type, refer to drawing or catalogue.
- When fixing the fan with screws, ensure the screwing torque. If the screwing torque is over the recommended screw torque, threaded holes may be damaged. Also, in order to prevent from loosening screw, please use plain washer and spring lock washer. For screwing torque of each fan type, contact SANYO DENKI or SANYO DENKI distributor.
- When excessive shock is given to fan, impeller may be protruded. Make sure that impeller does not touch cover such as inlet nozzle and finger guard, and mounting plate. For positional relation among the fan, inlet nozzle, and plate of each fan type, refer to drawing or catalog.
- Install the inlet nozzle, finger guard, and plate to the fan in the correct position while avoiding touching of the rotor blade. Avoiding this will prevent device failure. Please use SANYO DENKI genuine inlet nozzle.

Environment of usage

- The product must not be used or stored in a flammable or corrosive gas atmosphere, in a place where water or oil splashes (not applicable to Splash Proof or Oil Proof Fans), in a place where there is much dust or humidity, in a place where condensation occurs, in a place where the product is exposed to radioactive rays or is in direct sunlight, in a place where a salty sea breeze blows or seawater splashes, or in an environment where the product may be contaminated by such corrosive materials as sulfurous water, sulfurous volcanic ash, organic solvents, acidic chemicals, alkali chemicals, etc., such hazardous substances as nuclear fuel materials, etc. If it is used or stored in such places or environments, there is the possibility that a fire may occur, the product may malfunction or its performance may deteriorate.
- Avoid using or storing the product in locations and an environment where it could be constantly exposed to vibrations, strong shocks, centrifugal force, acceleration, magnetic or electromagnetic noise, and which the electromagnetic noise overlaps into power voltage. This might result in product breakdown or substandard operation.
- Avoid using or storing the product under environments where rapidly changed such as thermal and humidity change. This might result in product breakdown or deterioration.

Maintenance

- Maintenance and inspections should always be performed by personnel with sufficient training and knowledge. Failure to do so might result in fire, burns, bodily injury, or electrical shock.
- Never perform any maintenance or inspections while the product is in operation. Also note that the blades continue to rotate for some time immediately after operation ceases. You should always be sure to check to see that all rotating parts have come to a stop before beginning work.
- Never use gasoline, paint thinner, benzene, or any other organic solvents to clean the product as this could result in the deformation or substandard operation.

Safety Standards

List of safety standards acquired → refer to the index (pp. 495 to 517)

Description of safety standards

1. UL ratings (USA)



Underwriters Laboratories Inc. was established by the American Union of Fire Insurance Underwriters. The purpose of UL is to ensure safety of machines, equipment, and materials and protect human lives and property from fire and other accidents. To that end, UL has conducted numerous tests and extensive research and, as a result, set up UL ratings. Any seller of products in any of the majority of the states of the USA must produce their products according to the UL ratings, have them pass UL-specified safety inspections, and have them listed in UL's registration book. Therefore, to export and sell any product in the United States, one must in most cases apply for UL-listing. Additionally, UL is accredited by The Standards Council of Canada (SCC) as both a Certification Organization (CO) and a Testing Organization (TO) and is officially recognized in all provinces and territories throughout Canada. Accordingly, our products can be tested by UL for compliance with Canadian safety standards. Certified products are entitled to display the C-UL Mark, which authorizes their use and sale in Canada. If products are deemed to be compliant with both U.S. and Canadian standards, then both the UL Mark and C-UL Mark can be displayed or a combination U.S. and Canadian mark (bottom left). Our products are certified as satisfying all UL507 requirements.

2. CSA standards (Canada)



The Canadian Standards Association (CSA) was set up in response to the advice of the Canadian government. In Canada, the law prohibits the use and sale of any product other than those approved under CSA in terms of safety. CSA has set up CSA standards as inspection procedures and other requirements to ensure product safety. Our products are certified as satisfying the CSA standard C22.2 No. 113.

3. EN standards (EU members)



In the EU territory, the harmonization of industrial standards and safety standards of different countries is under way. The unified standards are called Harmonized Standards. Each of these standards is marked EN above the standard number. EN standards offer the grounds in design and manufacture when one exports a product to the EU territory. In order for a product to receive a safety marking, the product must be found to conform to TÜV, VDE, or other relevant standard. Our products are certified as satisfying all TÜV Rheinland EN60950 requirements.

4. Electrical appliance and material safety law



As of April 1, 2001, the Electrical Appliance and Material Control Law has been revised and reenacted as the Electrical Appliance and Material Safety Law. AC fans are classified as 'Blowers' under 'Electric motor-operated appliances'. They are categorized as electrical products other than specific electrical appliances (with the exception of some models) and are required to be labeled to indicate PSE certification.

5. CE marking



To distribute their equipment in the EU territory, manufacturers are obligated to give a CE marking as proof that the equipment conforms to related EU directives. Manufacturers use EN standards as criteria of judgment as to whether the equipment satisfies the requirements of specific directives or, in the absence of applicable EN standards, they use IEC standards. Manufacturers then prepare a self-declaration to indicate that the equipment conforms to related directives and apply a CE marking. (Depending on the degree of risk of the equipment, some kinds of equipment are required to receive type tests conducted by certified authorities and, after a type test certificate is obtained, manufacturers make a self-declaration.)

Scope of application and compulsory timing of major EC directives

Machine directives

These directives apply to equipment that has a moving part that may injure humans. The directives generally apply to a wide range of machine tools and other industrial machines.

EMC directives

They apply to equipment which may be affected by electromagnetic interference (EMI) or has electromagnetic susceptibility (EMS).

Low-voltage directive

This directive applies to equipment that is used in an AC range between 50 and 1,000V and in a DC range between 75 and 1,500V.

JIS: Japanese Industrial Standards

Japan's national standards related to mining and manufacturing industries

IEC : International Electrotechnical Commission

This is an international commission on electrical standardization. This commission promotes the unification and cooperation of international standards related to electric and electronics engineering and issues IEC standards in order eventually to allow different countries to conform to the international standards.

DIN : Deutsches Institut für Normung e.V.

This is a German standards institute. The institute uses a wide-range set of standards covering many industrial sectors. The set of standards includes basic standards.

VDE : Verband Deutscher Elektrotechniker e.V.

It is a German association of electric engineers. VDE establishes safety standards related to electrical engineering and issues them as DIN-VDE standards.

RoHS Directive

Since October 2012, all the products in this catalog have complied with the maximum concentration values of the hazardous substances referred to in the Annex II to EU RoHS Directive 2011/65/EU,* except for the exempted applications specified in the Annex III to the Directive.

Please note that SANYO DENKI does not use exemption 7(c)-III: Lead in dielectric ceramic in capacitors for a rated voltage of less than 125 V AC or 250 V DC, for those products.

* Lead, mercury, cadmium, hexavalent chromium, polybrominated biphenyls (PBB) and polybrominated diphenyl ethers (PBDE)

RoHS Directive:

DIRECTIVE 2011/65/EU OF THE EUROPEAN PARLIAMENT AND OF THE COUNCIL of 8 June 2011 on the restriction of the use of certain hazardous substances in electrical and electronic equipment

Index by Model No./Safety Standards List - DC Fans DC

Models listed in the main section of this catalog	List of models (models not listed in the main section of this catalog are options. Standards for optional model numbers may differ from the certified standards listed at right. Contact us for details of models with "-" model numbers.)				Frame Size	Rib	Standard (certification status is for the models listed in this catalog, and standards for optional model numbers may differ.)			page
	Without sensor	With pulse sensor	With lock sensor	With PWM control function and pulse sensor			UL	CSA	TÜV	
							(cUL)	(cUL)		
109BC12FC7-1	109BC12FA7-1	109BC12FC7-1	109BC12FD7-1	—	52mm×15mm	—	✓	✓	✓	393
109BC12GC7-1	109BC12GA7-1	109BC12GC7-1	109BC12GD7-1	—	52mm×15mm	—	✓	✓	✓	393
109BC12HC7-1	109BC12HA7-1	109BC12HC7-1	109BC12HD7-1	—	52mm×15mm	—	✓	✓	✓	393
109BC12MC7-1	109BC12MA7-1	109BC12MC7-1	109BC12MD7-1	—	52mm×15mm	—	✓	✓	✓	393
109BC24FC7-1	109BC24FA7-1	109BC24FC7-1	109BC24FD7-1	—	52mm×15mm	—	✓	✓	✓	393
109BC24GC7-1	109BC24GA7-1	109BC24GC7-1	109BC24GD7-1	—	52mm×15mm	—	✓	✓	✓	393
109BC24HC7-1	109BC24HA7-1	109BC24HC7-1	109BC24HD7-1	—	52mm×15mm	—	✓	✓	✓	393
109BD12FC2	109BD12FA2	109BD12FC2	109BD12FD2	—	76mm×30mm	—	✓	✓	✓	397
109BD12HC2	109BD12HA2	109BD12HC2	109BD12HD2	109BD12P2H01	76mm×30mm	—	✓	✓	✓	397
109BD12MC2	109BD12MA2	109BD12MC2	109BD12MD2	—	76mm×30mm	—	✓	✓	✓	397
109BD24FC2	109BD24FA2	109BD24FC2	109BD24FD2	—	76mm×30mm	—	✓	✓	✓	397
109BD24HC2	109BD24HA2	109BD24HC2	109BD24HD2	—	76mm×30mm	—	✓	✓	✓	397
109BD24MC2	109BD24MA2	109BD24MC2	109BD24MD2	—	76mm×30mm	—	✓	✓	✓	397
109BG12HC1	109BG12HA1	109BG12HC1	109BG12HD1	—	160mm×40mm	—	✓	✓	✓	410
109BG12MC1	109BG12MA1	109BG12MC1	109BG12MD1	—	160mm×40mm	—	✓	✓	✓	410
109BG24HC1	109BG24HA1	109BG24HC1	109BG24HD1	—	160mm×40mm	—	✓	✓	✓	410
109BG24MC1	109BG24MA1	109BG24MC1	109BG24MD1	—	160mm×40mm	—	✓	✓	✓	410
109BJ12HC2	109BJ12HA2	109BJ12HC2	109BJ12HD2	—	127mm×32mm	—	✓	✓	✓	409
109BJ12MC2	109BJ12MA2	109BJ12MC2	109BJ12MD2	—	127mm×32mm	—	✓	✓	✓	409
109BJ24HC2	109BJ24HA2	109BJ24HC2	109BJ24HD2	—	127mm×32mm	—	✓	✓	✓	409
109BJ24MC2	109BJ24MA2	109BJ24MC2	109BJ24MD2	—	127mm×32mm	—	✓	✓	✓	409
109BM12GC2-1	109BM12GA2-1	109BM12GC2-1	109BM12GD2-1	—	97mm×33mm	—	✓	✓	✓	399
109BM12HC2-1	109BM12HA2-1	109BM12HC2-1	109BM12HD2-1	—	97mm×33mm	—	✓	✓	✓	399
109BM12MC2-1	109BM12MA2-1	109BM12MC2-1	109BM12MD2-1	109BM12P2M01	97mm×33mm	—	✓	✓	✓	399
109BM24GC2-1	109BM24GA2-1	109BM24GC2-1	109BM24GD2-1	—	97mm×33mm	—	✓	✓	✓	399
109BM24HC2-1	109BM24HA2-1	109BM24HC2-1	109BM24HD2-1	—	97mm×33mm	—	✓	✓	✓	399
109BM24MC2-1	109BM24MA2-1	109BM24MC2-1	109BM24MD2-1	—	97mm×33mm	—	✓	✓	✓	399
109E1312A101	109E1312A102	109E1312A101	109E1312A1D01	—	127×127×38mm	No	✓	✓	✓	181
109E1312S101	109E1312S102	109E1312S101	109E1312S1D01	—	127×127×38mm	No	✓	✓	✓	181
109E1324A101	109E1324A102	109E1324A101	109E1324A1D01	—	127×127×38mm	No	✓	✓	✓	181
109E1324G101	109E1324G102	109E1324G101	109E1324G1D01	—	127×127×38mm	No	✓	✓	✓	181
109E1324S101	109E1324S102	109E1324S101	109E1324S1D01	—	127×127×38mm	No	✓	✓	✓	181
109E1348A101	109E1348A102	109E1348A101	109E1348A1D01	—	127×127×38mm	No	✓	✓	✓	181
109E1348G101	109E1348G102	109E1348G101	109E1348G1D01	—	127×127×38mm	No	✓	✓	✓	181
109E1348S101	109E1348S102	109E1348S101	109E1348S1D01	—	127×127×38mm	No	✓	✓	✓	181
109E1712F501	109E1712F502	109E1712F501	109E1712F5D01	—	φ172mm×51mm	No	✓	✓	✓	201
109E1712H501	109E1712H502	109E1712H501	109E1712H5D01	—	φ172mm×51mm	No	✓	✓	✓	201
109E1712K501	109E1712K502	109E1712K501	—	—	φ172mm×51mm	No	✓	✓	✓	201
109E1712M501	109E1712M502	109E1712M501	—	—	φ172mm×51mm	No	✓	✓	✓	201
109E1712Y501	109E1712Y502	109E1712Y501	—	—	φ172mm×51mm	No	✓	✓	✓	201
109E1724C501	109E1724C502	109E1724C501	109E1724C5D01	9EH1724P5C01	φ172mm×51mm	No	✓	✓	✓	201
109E1724F501	109E1724F502	109E1724F501	109E1724F5D01	—	φ172mm×51mm	No	✓	✓	✓	201
109E1724H501	109E1724H502	109E1724H501	109E1724H5D01	—	φ172mm×51mm	No	✓	✓	✓	201
109E1724K501	109E1724K502	109E1724K501	109E1724K5D01	—	φ172mm×51mm	No	✓	✓	✓	201
109E1724M501	109E1724M502	109E1724M501	109E1724M5D01	—	φ172mm×51mm	No	✓	✓	✓	201
109E1748C501	109E1748C502	109E1748C501	—	—	φ172mm×51mm	No	✓	✓	✓	201
109E1748F501	109E1748F502	109E1748F501	—	—	φ172mm×51mm	No	✓	✓	✓	201
109E1748H501	109E1748H502	109E1748H501	109E1748H5D01	—	φ172mm×51mm	No	✓	✓	✓	201
109E1748K501	109E1748K502	109E1748K501	—	109E1748P5K03	φ172mm×51mm	No	✓	✓	✓	201
109E1748M501	109E1748M502	109E1748M501	—	—	φ172mm×51mm	No	✓	✓	✓	201
109E4712L401	109E4712L402	109E4712L401	109E4712L4D01	—	φ172mm×147mm×25mm	No	✓	✓	✓	191
109E4712M401	109E4712M402	109E4712M401	109E4712M4D01	—	φ172mm×147mm×25mm	No	✓	✓	✓	191
109E4724F401	109E4724F402	109E4724F401	109E4724F4D01	—	φ172mm×147mm×25mm	No	✓	✓	✓	191
109E4724H401	109E4724H402	109E4724H401	109E4724H4D01	109E4724P4H01	φ172mm×147mm×25mm	No	✓	✓	✓	191

Please contact your point of sale regarding low-speed sensors.

Standard name	Certification number
UL	E46810
CSA	172248

※TÜV certification numbers differ by model.

※The content of this catalog is current as of September 2016.

Please ask us about new products that we released after September 2016 if you want.

Models listed in the main section of this catalog	List of models (models not listed in the main section of this catalog are options. Standards for optional model numbers may differ from the certified standards listed at right. Contact us for details of models with "-" model numbers.)				Frame Size	Rib	Standard (certification status is for the models listed in this catalog, and standards for optional model numbers may differ.)			page
	Without sensor	With pulse sensor	With lock sensor	With PWM control function and pulse sensor			UL (cUL)	CSA (cUL)	TÜV	
							✓	✓	✓	
109E4724L401	109E4724L402	109E4724L401	109E4724L4D01	—	φ 172mm × 147mm × 25mm	No	✓	✓	✓	191
109E4724M401	109E4724M402	109E4724M401	109E4724M4D01	—	φ 172mm × 147mm × 25mm	No	✓	✓	✓	191
109E4748F401	109E4748F402	109E4748F401	109E4748F4D01	—	φ 172mm × 147mm × 25mm	No	✓	✓	✓	191
109E4748H401	109E4748H402	109E4748H401	109E4748H4D01	—	φ 172mm × 147mm × 25mm	No	✓	✓	✓	191
109E4748L401	109E4748L402	109E4748L401	109E4748L4D01	—	φ 172mm × 147mm × 25mm	No	✓	✓	✓	191
109E4748M401	109E4748M402	109E4748M401	109E4748M4D01	—	φ 172mm × 147mm × 25mm	No	✓	✓	✓	191
109E4748S401	109E4748S402	109E4748S401	109E4748S4D01	—	φ 172mm × 147mm × 25mm	No	✓	✓	✓	191
109E5712F501	109E5712F502	109E5712F501	—	—	φ 172mm × 150mm × 51mm	No	✓	✓	✓	199
109E5712H501	109E5712H502	109E5712H501	109E5712H5D01	—	φ 172mm × 150mm × 51mm	No	✓	✓	✓	199
109E5712K501	109E5712K502	109E5712K501	109E5712K5D01	109E5712P5K04	φ 172mm × 150mm × 51mm	No	✓	✓	✓	199
109E5712M501	109E5712M502	109E5712M501	109E5712M5D01	—	φ 172mm × 150mm × 51mm	No	✓	✓	✓	199
109E5712Y501	109E5712Y502	109E5712Y501	—	—	φ 172mm × 150mm × 51mm	No	✓	✓	✓	199
109E5724C501	109E5724C502	109E5724C501	109E5724C5D01	9EH5724P5C01	φ 172mm × 150mm × 51mm	No	✓	✓	✓	199
109E5724F501	109E5724F502	109E5724F501	—	—	φ 172mm × 150mm × 51mm	No	✓	✓	✓	199
109E5724H501	109E5724H502	109E5724H501	109E5724H5D01	—	φ 172mm × 150mm × 51mm	No	✓	✓	✓	199
109E5724K501	109E5724K502	109E5724K501	109E5724K5D01	—	φ 172mm × 150mm × 51mm	No	✓	✓	✓	199
109E5724M501	109E5724M502	109E5724M501	—	—	φ 172mm × 150mm × 51mm	No	✓	✓	✓	199
109E5748C501	109E5748C502	109E5748C501	—	—	φ 172mm × 150mm × 51mm	No	✓	✓	✓	199
109E5748F501	109E5748F502	109E5748F501	—	—	φ 172mm × 150mm × 51mm	No	✓	✓	✓	199
109E5748H501	109E5748H502	109E5748H501	109E5748H5D01	—	φ 172mm × 150mm × 51mm	No	✓	✓	✓	199
109E5748K501	109E5748K502	109E5748K501	—	—	φ 172mm × 150mm × 51mm	No	✓	✓	✓	199
109E5748M501	109E5748M502	109E5748M501	—	—	φ 172mm × 150mm × 51mm	No	✓	✓	✓	199
109L1412H101	109L1412H102	109L1412H101	109L1412H1D01	—	140 × 140 × 38mm	No	✓	✓	✓	349
109L1412M101	109L1412M102	109L1412M101	—	—	140 × 140 × 38mm	No	✓	✓	✓	349
109L1424H101	109L1424H102	109L1424H101	109L1424H1D01	—	140 × 140 × 38mm	No	✓	✓	✓	349
109L1424M101	109L1424M102	109L1424M101	109L1424M1D01	—	140 × 140 × 38mm	No	✓	✓	✓	349
109L1448H101	109L1448H102	109L1448H101	109L1448H1D01	—	140 × 140 × 38mm	No	✓	✓	✓	349
109L1448M101	109L1448M102	109L1448M101	109L1448M1D01	—	140 × 140 × 38mm	No	✓	✓	✓	349
109L1712H501	109L1712H502	109L1712H501	109L1712H5D01	—	φ 172mm × 51mm	No	✓	✓	✓	355
109L1712M501	109L1712M502	109L1712M501	109L1712M5D01	—	φ 172mm × 51mm	No	✓	✓	✓	355
109L1724H501	109L1724H502	109L1724H501	109L1724H5D01	—	φ 172mm × 51mm	No	✓	✓	✓	355
109L1724M501	109L1724M502	109L1724M501	109L1724M5D01	—	φ 172mm × 51mm	No	✓	✓	✓	355
109L1748H501	109L1748H502	109L1748H501	109L1748H5D01	—	φ 172mm × 51mm	No	✓	✓	✓	355
109L1748M501	109L1748M502	109L1748M501	109L1748M5D01	—	φ 172mm × 51mm	No	✓	✓	✓	355
109L5712H501	109L5712H502	109L5712H501	109L5712H5D01	—	φ 172mm × 150mm × 51mm	No	✓	✓	✓	353
109L5712M501	109L5712M502	109L5712M501	109L5712M5D01	—	φ 172mm × 150mm × 51mm	No	✓	✓	✓	353
109L5724H501	109L5724H502	109L5724H501	109L5724H5D01	—	φ 172mm × 150mm × 51mm	No	✓	✓	✓	353
109L5724M501	109L5724M502	109L5724M501	109L5724M5D01	—	φ 172mm × 150mm × 51mm	No	✓	✓	✓	353
109L5748H501	109L5748H502	109L5748H501	109L5748H5D01	—	φ 172mm × 150mm × 51mm	No	✓	✓	✓	353
109L5748M501	109L5748M502	109L5748M501	109L5748M5D01	—	φ 172mm × 150mm × 51mm	No	✓	✓	✓	353
109P0405F3013	109P0405F3023	109P0405F3013	109P0405F3D013	—	40 × 40 × 28mm	Yes	✓	✓	✓	43
109P0405F601	109P0405F602	109P0405F601	109P0405F6D01	—	40 × 40 × 20mm	Yes	✓	✓	✓	27
109P0405H3013	109P0405H3023	109P0405H3013	109P0405H3D013	—	40 × 40 × 28mm	Yes	✓	✓	✓	43
109P0405H601	109P0405H602	109P0405H601	109P0405H6D01	—	40 × 40 × 20mm	Yes	✓	✓	✓	27
109P0405H701	109P0405H702	109P0405H701	109P0405H7D01	—	40 × 40 × 15mm	Yes	✓	✓	✓	21
109P0405H901	109P0405H902	109P0405H901	109P0405H9D01	—	40 × 40 × 10mm	Yes	✓	✓	✓	17
109P0405J601	109P0405J602	109P0405J601	—	—	40 × 40 × 20mm	Yes	✓	✓	✓	27
109P0405M601	109P0405M602	109P0405M601	109P0405M6D01	—	40 × 40 × 20mm	Yes	✓	✓	✓	27
109P0405M701	109P0405M702	109P0405M701	109P0405M7D01	—	40 × 40 × 15mm	Yes	✓	✓	✓	21
109P0405M901	109P0405M902	109P0405M901	109P0405M9D01	—	40 × 40 × 10mm	Yes	✓	✓	✓	17
109P0412B3013	109P0412B3023	109P0412B3013	109P0412B3D013	109P0412P3B013	40 × 40 × 28mm	Yes	✓	✓	✓	43
109P0412D601	109P0412D602	109P0412D601	109P0412D6D01	—	40 × 40 × 20mm	Yes	✓	✓	✓	27
109P0412E601	109P0412E602	109P0412E601	109P0412E6D01	—	40 × 40 × 20mm	Yes	✓	✓	✓	27
109P0412F3013	109P0412F3023	109P0412F3013	109P0412F3D013	—	40 × 40 × 28mm	Yes	✓	✓	✓	43
109P0412F601	109P0412F602	109P0412F601	109P0412F6D01	—	40 × 40 × 20mm	Yes	✓	✓	✓	27
109P0412G3013	109P0412G3023	109P0412G3013	109P0412G3D013	—	40 × 40 × 28mm	Yes	✓	✓	✓	43
109P0412G601	109P0412G602	109P0412G601	109P0412G6D01	—	40 × 40 × 20mm	Yes	✓	✓	✓	27
109P0412H3013	109P0412H3023	109P0412H3013	109P0412H3D013	109P0412P3H013	40 × 40 × 28mm	Yes	✓	✓	✓	43
109P0412H601	109P0412H602	109P0412H601	109P0412H6D01	—	40 × 40 × 20mm	Yes	✓	✓	✓	27
109P0412H701	109P0412H702	109P0412H701	109P0412H7D01	—	40 × 40 × 15mm	Yes	✓	✓	✓	21
109P0412H901	109P0412H902	109P0412H901	109P0412H9D01	—	40 × 40 × 10mm	Yes	✓	✓	✓	17
109P0412J3013	109P0412J3023	109P0412J3013	109P0412J3D013	—	40 × 40 × 28mm	Yes	✓	✓	✓	43

Please contact your point of sale regarding low-speed sensors.

Models listed in the main section of this catalog	List of models (models not listed in the main section of this catalog are options. Standards for optional model numbers may differ from the certified standards listed at right. Contact us for details of models with "-" model numbers.)				Frame Size	Rib	Standard (certification status is for the models listed in this catalog, and standards for optional model numbers may differ.)			page
	Without sensor	With pulse sensor	With lock sensor	With PWM control function and pulse sensor			UL	CSA	TÜV	
							(cUL)	(cUL)		
109P0412K3013	109P0412K3023	109P0412K3013	109P0412K3D013	9PH0412P3K033	40×40×28mm	Yes	✓	✓	✓	43
109P0412M3013	109P0412M3023	109P0412M3013	109P0412M3D013	—	40×40×28mm	Yes	✓	✓	✓	43
109P0412M601	109P0412M602	109P0412M601	109P0412M6D01	—	40×40×20mm	Yes	✓	✓	✓	27
109P0412M701	109P0412M702	109P0412M701	109P0412M7D01	—	40×40×15mm	Yes	✓	✓	✓	21
109P0412M901	109P0412M902	109P0412M901	109P0412M9D01	—	40×40×10mm	Yes	✓	✓	✓	17
109P0412R701	109P0412R702	109P0412R701	109P0412R7D01	—	40×40×15mm	Yes	✓	✓	✓	21
109P0412S701	109P0412S702	109P0412S701	109P0412S7D01	—	40×40×15mm	Yes	✓	✓	✓	21
109P0424B3013	109P0424B3023	109P0424B3013	109P0424B3D013	—	40×40×28mm	Yes	✓	✓	✓	43
109P0424B601	109P0424B602	109P0424B601	109P0424B6D01	—	40×40×20mm	Yes	✓	✓	✓	27
109P0424D601	109P0424D602	109P0424D601	109P0424D6D01	—	40×40×20mm	Yes	✓	✓	✓	27
109P0424F3013	109P0424F3023	109P0424F3013	109P0424F3D013	—	40×40×28mm	Yes	✓	✓	✓	43
109P0424F601	109P0424F602	109P0424F601	109P0424F6D01	—	40×40×20mm	Yes	✓	✓	✓	27
109P0424G3013	109P0424G3023	109P0424G3013	109P0424G3D013	—	40×40×28mm	Yes	✓	✓	✓	43
109P0424G601	109P0424G602	109P0424G601	109P0424G6D01	—	40×40×20mm	Yes	✓	✓	✓	27
109P0424H3013	109P0424H3023	109P0424H3013	109P0424H3D013	—	40×40×28mm	Yes	✓	✓	✓	43
109P0424H601	109P0424H602	109P0424H601	109P0424H6D01	—	40×40×20mm	Yes	✓	✓	✓	27
109P0424H701	109P0424H702	109P0424H701	109P0424H7D01	—	40×40×15mm	Yes	✓	✓	✓	21
109P0424J3013	109P0424J3023	109P0424J3013	109P0424J3D013	—	40×40×28mm	Yes	✓	✓	✓	43
109P0424R3013	109P0424R3023	109P0424R3013	—	—	40×40×28mm	Yes	—	—	—	43
109P0505M701	109P0505M702	109P0505M701	109P0505M7D01	—	52×52×15mm	Yes	✓	✓	✓	51
109P0512A701	109P0512A702	109P0512A701	109P0512A7D01	—	52×52×15mm	Yes	✓	✓	✓	51
109P0512H701	109P0512H702	109P0512H701	109P0512H7D01	—	52×52×15mm	Yes	✓	✓	✓	51
109P0512M701	109P0512M702	109P0512M701	109P0512M7D01	—	52×52×15mm	Yes	✓	✓	✓	51
109P0524A701	109P0524A702	109P0524A701	109P0524A7D01	—	52×52×15mm	Yes	✓	✓	✓	51
109P0524H701	109P0524H702	109P0524H701	109P0524H7D01	—	52×52×15mm	Yes	✓	✓	✓	51
109P0524M701	109P0524M702	109P0524M701	109P0524M7D01	—	52×52×15mm	Yes	✓	✓	✓	51
109P0605H701	109P0605H702	109P0605H701	109P0605H7D01	—	60×60×15mm	Yes	✓	✓	✓	59
109P0605M701	109P0605M702	109P0605M701	109P0605M7D01	—	60×60×15mm	Yes	✓	✓	✓	59
109P0612B701	109P0612B702	109P0612B701	109P0612B7D01	—	60×60×15mm	Yes	✓	✓	✓	59
109P0612H601	109P0612H602	109P0612H601	109P0612H6D01	—	60×60×20mm	Yes	✓	✓	✓	65
109P0612H701	109P0612H702	109P0612H701	109P0612H7D01	—	60×60×15mm	Yes	✓	✓	✓	59
109P0612K701	109P0612K702	109P0612K701	109P0612K7D01	—	60×60×15mm	Yes	✓	✓	✓	59
109P0612M601	109P0612M602	109P0612M601	109P0612M6D01	—	60×60×20mm	Yes	✓	✓	✓	65
109P0612M701	109P0612M702	109P0612M701	109P0612M7D01	—	60×60×15mm	Yes	✓	✓	✓	59
109P0612S701	109P0612S702	109P0612S701	109P0612S7D01	—	60×60×15mm	Yes	✓	✓	✓	59
109P0612V601	109P0612V602	109P0612V601	109P0612V6D01	—	60×60×20mm	Yes	✓	✓	✓	65
109P0624H601	109P0624H602	109P0624H601	109P0624H6D01	—	60×60×20mm	Yes	✓	✓	✓	65
109P0624H701	109P0624H702	109P0624H701	109P0624H7D01	—	60×60×15mm	Yes	✓	✓	✓	59
109P0624J701	109P0624J702	109P0624J701	109P0624J7D01	—	60×60×15mm	Yes	✓	✓	✓	59
109P0624M601	109P0624M602	109P0624M601	109P0624M6D01	—	60×60×20mm	Yes	✓	✓	✓	65
109P0624M701	109P0624M702	109P0624M701	109P0624M7D01	—	60×60×15mm	Yes	✓	✓	✓	59
109P0624S701	109P0624S702	109P0624S701	109P0624S7D01	—	60×60×15mm	Yes	✓	✓	✓	59
109P0624V601	109P0624V602	109P0624V601	109P0624V6D01	—	60×60×20mm	Yes	✓	✓	✓	65
109P0648H601	109P0648H602	109P0648H601	109P0648H6D01	—	60×60×20mm	Yes	✓	✓	✓	65
109P0812A201	109P0812A202	109P0812A201	109P0812A2D01	—	80×80×32mm	Yes	✓	✓	✓	121
109P0812A2011	109P0812A2021	109P0812A2011	109P0812A2D011	—	80×80×32mm	No	✓	✓	✓	121
109P0812C601	109P0812C602	109P0812C601	109P0812C6D01	—	80×80×20mm	Yes	—	—	—	99
109P0812H201	109P0812H202	109P0812H201	109P0812H2D01	—	80×80×32mm	Yes	✓	✓	✓	121
109P0812H2011	109P0812H2021	109P0812H2011	109P0812H2D011	—	80×80×32mm	No	✓	✓	✓	121
109P0812H601	109P0812H602	109P0812H601	109P0812H6D01	—	80×80×20mm	Yes	✓	✓	✓	99
109P0812H701	109P0812H702	109P0812H701	109P0812H7D01	—	80×80×15mm	Yes	✓	✓	✓	95
109P0812M201	109P0812M202	109P0812M201	109P0812M2D01	—	80×80×32mm	Yes	✓	✓	✓	121
109P0812M2011	109P0812M2021	109P0812M2011	109P0812M2D011	—	80×80×32mm	No	✓	✓	✓	121
109P0812M601	109P0812M602	109P0812M601	109P0812M6D01	—	80×80×20mm	Yes	✓	✓	✓	99
109P0812M701	109P0812M702	109P0812M701	109P0812M7D01	—	80×80×15mm	Yes	✓	✓	✓	95
109P0824A201	109P0824A202	109P0824A201	109P0824A2D01	—	80×80×32mm	Yes	✓	✓	✓	121
109P0824A2011	109P0824A2021	109P0824A2011	—	—	80×80×32mm	No	✓	✓	✓	121
109P0824H201	109P0824H202	109P0824H201	109P0824H2D01	—	80×80×32mm	Yes	✓	✓	✓	121
109P0824H2011	109P0824H2021	109P0824H2011	109P0824H2D011	—	80×80×32mm	No	✓	✓	✓	121
109P0824H601	109P0824H602	109P0824H601	109P0824H6D01	—	80×80×20mm	Yes	✓	✓	✓	99
109P0824H701	109P0824H702	109P0824H701	109P0824H7D01	—	80×80×15mm	Yes	✓	✓	✓	95
109P0824M201	109P0824M202	109P0824M201	109P0824M2D01	—	80×80×32mm	Yes	✓	✓	✓	121

Models listed in the main section of this catalog	List of models (models not listed in the main section of this catalog are options. Standards for optional model numbers may differ from the certified standards listed at right. Contact us for details of models with "-" model numbers.)				Frame Size	Rib	Standard (certification status is for the models listed in this catalog, and standards for optional model numbers may differ.)			page
	Without sensor	With pulse sensor	With lock sensor	With PWM control function and pulse sensor			UL (cUL)	CSA (cUL)	TÜV	
109P0824M2011	109P0824M2021	109P0824M2011	109P0824M2D011	—	80×80×32mm	No	✓	✓	✓	121
109P0824M601	109P0824M602	109P0824M601	109P0824M6D01	—	80×80×20mm	Yes	✓	✓	✓	99
109P0824M701	109P0824M702	109P0824M701	109P0824M7D01	—	80×80×15mm	Yes	✓	✓	✓	95
109P0848C601	109P0848C602	109P0848C601	109P0848C6D01	—	80×80×20mm	Yes	✓	✓	✓	99
109P0848H201	109P0848H202	109P0848H201	109P0848H2D01	—	80×80×32mm	Yes	✓	✓	✓	121
109P0848H2011	109P0848H2021	109P0848H2011	—	—	80×80×32mm	No	✓	✓	✓	121
109P0848H601	—	109P0848H601	109P0848H6D01	—	80×80×20mm	Yes	✓	✓	✓	99
109P1312H101	109P1312H102	109P1312H101	109P1312H1D01	—	127×127×38mm	Yes	✓	✓	✓	179
109P1312H1011	109P1312H1021	109P1312H1011	109P1312H1D011	—	127×127×38mm	No	✓	✓	✓	179
109P1312S101	109P1312S102	109P1312S101	109P1312S1D01	—	127×127×38mm	Yes	✓	✓	✓	179
109P1312S1011	109P1312S1021	109P1312S1011	109P1312S1D011	—	127×127×38mm	No	✓	✓	✓	179
109P1324H101	109P1324H102	109P1324H101	109P1324H1D01	—	127×127×38mm	Yes	✓	✓	✓	179
109P1324H1011	109P1324H1021	109P1324H1011	109P1324H1D011	—	127×127×38mm	No	✓	✓	✓	179
109P1324S101	109P1324S102	109P1324S101	109P1324S1D01	—	127×127×38mm	Yes	✓	✓	✓	179
109P1324S1011	109P1324S1021	109P1324S1011	109P1324S1D011	—	127×127×38mm	No	✓	✓	✓	179
109P1348H101	109P1348H102	109P1348H101	109P1348H1D01	—	127×127×38mm	Yes	✓	✓	✓	179
109P1348H1011	109P1348H1021	109P1348H1011	109P1348H1D011	—	127×127×38mm	No	✓	✓	✓	179
109P1348S101	109P1348S102	109P1348S101	109P1348S1D01	—	127×127×38mm	Yes	✓	✓	✓	179
109P1348S1011	109P1348S1021	109P1348S1011	109P1348S1D011	—	127×127×38mm	No	✓	✓	✓	179
109P1412H101	109P1412H102	109P1412H101	109P1412H1D01	—	140×140×38mm	Yes	✓	✓	✓	187
109P1412M101	109P1412M102	109P1412M101	—	—	140×140×38mm	Yes	✓	✓	✓	187
109P1424H101	109P1424H102	109P1424H101	109P1424H1D01	—	140×140×38mm	Yes	✓	✓	✓	187
109P1424M101	109P1424M102	109P1424M101	—	—	140×140×38mm	Yes	✓	✓	✓	187
109P1448H101	109P1448H102	109P1448H101	—	—	140×140×38mm	Yes	✓	✓	✓	187
109P1448M101	109P1448M102	109P1448M101	—	—	140×140×38mm	Yes	✓	✓	✓	187
109R0605F401	109R0605F402	109R0605F401	109R0605F4D01	—	60×60×25mm	Yes	✓	✓	✓	71
109R0605F4011	109R0605F4021	109R0605F4011	—	—	60×60×25mm	No	✓	✓	✓	71
109R0605H401	109R0605H402	109R0605H401	109R0605H4D01	—	60×60×25mm	Yes	✓	✓	✓	71
109R0605H4011	109R0605H4021	109R0605H4011	—	—	60×60×25mm	No	✓	✓	✓	71
109R0605M401	109R0605M402	109R0605M401	109R0605M4D01	—	60×60×25mm	Yes	✓	✓	✓	71
109R0605M4011	109R0605M4021	109R0605M4011	—	—	60×60×25mm	No	✓	✓	✓	71
109R0612D401	109R0612D402	109R0612D401	109R0612D4D01	—	60×60×25mm	Yes	✓	✓	✓	71
109R0612D4011	109R0612D4021	109R0612D4011	109R0612D4D011	—	60×60×25mm	No	✓	✓	✓	71
109R0612F401	109R0612F402	109R0612F401	109R0612F4D01	—	60×60×25mm	Yes	✓	✓	✓	71
109R0612F4011	109R0612F4021	109R0612F4011	109R0612F4D011	—	60×60×25mm	No	✓	✓	✓	71
109R0612G401	109R0612G402	109R0612G401	109R0612G4D01	—	60×60×25mm	Yes	✓	✓	✓	71
109R0612G4011	109R0612G4021	109R0612G4011	109R0612G4D011	—	60×60×25mm	No	✓	✓	✓	71
109R0612H401	109R0612H402	109R0612H401	109R0612H4D01	—	60×60×25mm	Yes	✓	✓	✓	71
109R0612H4011	109R0612H4021	109R0612H4011	109R0612H4D011	—	60×60×25mm	No	✓	✓	✓	71
109R0612J401	109R0612J402	109R0612J401	109R0612J4D01	109R0612P4J03	60×60×25mm	Yes	✓	✓	✓	71
109R0612J4011	109R0612J4021	109R0612J4011	109R0612J4D011	109R0612P4J061	60×60×25mm	No	✓	✓	✓	71
109R0612M401	109R0612M402	109R0612M401	109R0612M4D01	—	60×60×25mm	Yes	✓	✓	✓	71
109R0612M4011	109R0612M4021	109R0612M4011	109R0612M4D011	—	60×60×25mm	No	✓	✓	✓	71
109R0612S401	109R0612S402	109R0612S401	109R0612S4D01	—	60×60×25mm	Yes	✓	✓	✓	71
109R0612S4011	109R0612S4021	109R0612S4011	109R0612S4D011	—	60×60×25mm	No	✓	✓	✓	71
109R0624D401	109R0624D402	109R0624D401	109R0624D4D01	—	60×60×25mm	Yes	✓	✓	✓	71
109R0624D4011	109R0624D4021	109R0624D4011	—	—	60×60×25mm	No	✓	✓	✓	71
109R0624F401	109R0624F402	109R0624F401	109R0624F4D01	—	60×60×25mm	Yes	✓	✓	✓	71
109R0624F4011	109R0624F4021	109R0624F4011	109R0624F4D011	—	60×60×25mm	No	✓	✓	✓	71
109R0624G401	109R0624G402	109R0624G401	109R0624G4D01	—	60×60×25mm	Yes	✓	✓	✓	71
109R0624G4011	109R0624G4021	109R0624G4011	109R0624G4D011	—	60×60×25mm	No	✓	✓	✓	71
109R0624H401	109R0624H402	109R0624H401	109R0624H4D01	—	60×60×25mm	Yes	✓	✓	✓	71
109R0624H4011	109R0624H4021	109R0624H4011	109R0624H4D011	—	60×60×25mm	No	✓	✓	✓	71
109R0624J401	109R0624J402	109R0624J401	109R0624J4D01	9RH0624P4J01	60×60×25mm	Yes	✓	✓	✓	71
109R0624J4011	109R0624J4021	109R0624J4011	109R0624J4D011	—	60×60×25mm	No	✓	✓	✓	71
109R0624M401	109R0624M402	109R0624M401	109R0624M4D01	—	60×60×25mm	Yes	✓	✓	✓	71
109R0624M4011	109R0624M4021	109R0624M4011	109R0624M4D011	—	60×60×25mm	No	✓	✓	✓	71
109R0624S401	109R0624S402	109R0624S401	109R0624S4D01	—	60×60×25mm	Yes	✓	✓	✓	71
109R0624S4011	109R0624S4021	109R0624S4011	109R0624S4D011	—	60×60×25mm	No	✓	✓	✓	71
109R0648G401	109R0648G402	109R0648G401	109R0648G4D01	—	60×60×25mm	Yes	✓	✓	✓	71
109R0648G4011	109R0648G4021	109R0648G4011	109R0648G4D011	—	60×60×25mm	No	✓	✓	✓	71
109R0648H401	109R0648H402	109R0648H401	109R0648H4D01	—	60×60×25mm	Yes	✓	✓	✓	71

Models listed in the main section of this catalog	List of models (models not listed in the main section of this catalog are options. Standards for optional model numbers may differ from the certified standards listed at right. Contact us for details of models with "-" model numbers.)				Frame Size	Rib	Standard (certification status is for the models listed in this catalog, and standards for optional model numbers may differ.)			page
	Without sensor	With pulse sensor	With lock sensor	With PWM control function and pulse sensor			UL (cUL)	CSA (cUL)	TÜV	
	109R0648H4011	109R0648H4021	109R0648H4011	109R0648H4D011			—	60×60×25mm	No	
109R0648J401	109R0648J402	109R0648J401	109R0648J4D01	—	60×60×25mm	Yes	✓	✓	✓	71
109R0648J4011	109R0648J4021	109R0648J4011	—	—	60×60×25mm	No	✓	✓	✓	71
109R0805F401	109R0805F402	109R0805F401	109R0805F4D01	—	80×80×25mm	Yes	✓	✓	✓	111
109R0805F4011	109R0805F4021	109R0805F4011	—	—	80×80×25mm	No	✓	✓	✓	111
109R0805M401	109R0805M402	109R0805M401	109R0805M4D01	—	80×80×25mm	Yes	✓	✓	✓	111
109R0805M4011	109R0805M4021	109R0805M4011	—	—	80×80×25mm	No	✓	✓	✓	111
109R0812E401	109R0812E402	109R0812E401	—	—	80×80×25mm	Yes	—	—	—	111
109R0812E4011	—	109R0812E4011	—	—	80×80×25mm	No	—	—	—	111
109R0812F401	109R0812F402	109R0812F401	109R0812F4D01	—	80×80×25mm	Yes	✓	✓	✓	111
109R0812F4011	109R0812F4021	109R0812F4011	109R0812F4D011	—	80×80×25mm	No	✓	✓	✓	111
109R0812G401	109R0812G402	109R0812G401	109R0812G4D01	—	80×80×25mm	Yes	✓	✓	✓	111
109R0812G4011	109R0812G4021	109R0812G4011	109R0812G4D011	—	80×80×25mm	No	✓	✓	✓	111
109R0812H401	109R0812H402	109R0812H401	109R0812H4D01	—	80×80×25mm	Yes	✓	✓	✓	111
109R0812H4011	109R0812H4021	109R0812H4011	109R0812H4D011	—	80×80×25mm	No	✓	✓	✓	111
109R0812L401	109R0812L402	109R0812L401	109R0812L4D01	—	80×80×25mm	Yes	✓	✓	✓	111
109R0812L4011	109R0812L4021	109R0812L4011	109R0812L4D011	—	80×80×25mm	No	✓	✓	✓	111
109R0812M401	109R0812M402	109R0812M401	109R0812M4D01	—	80×80×25mm	Yes	✓	✓	✓	111
109R0812M4011	109R0812M4021	109R0812M4011	109R0812M4D011	—	80×80×25mm	No	✓	✓	✓	111
109R0812S401	109R0812S402	109R0812S401	109R0812S4D01	—	80×80×25mm	Yes	✓	✓	✓	111
109R0812S4011	109R0812S4021	109R0812S4011	109R0812S4D011	—	80×80×25mm	No	✓	✓	✓	111
109R0824F401	109R0824F402	109R0824F401	109R0824F4D01	—	80×80×25mm	Yes	✓	✓	✓	111
109R0824F4011	109R0824F4021	109R0824F4011	109R0824F4D011	—	80×80×25mm	No	✓	✓	✓	111
109R0824G401	109R0824G402	109R0824G401	109R0824G4D01	—	80×80×25mm	Yes	✓	✓	✓	111
109R0824G4011	109R0824G4021	109R0824G4011	109R0824G4D011	—	80×80×25mm	No	✓	✓	✓	111
109R0824H401	109R0824H402	109R0824H401	109R0824H4D01	—	80×80×25mm	Yes	✓	✓	✓	111
109R0824H4011	109R0824H4021	109R0824H4011	109R0824H4D011	—	80×80×25mm	No	✓	✓	✓	111
109R0824L401	109R0824L402	109R0824L401	109R0824L4D01	—	80×80×25mm	Yes	✓	✓	✓	111
109R0824L4011	109R0824L4021	109R0824L4011	109R0824L4D011	—	80×80×25mm	No	✓	✓	✓	111
109R0824M401	109R0824M402	109R0824M401	109R0824M4D01	—	80×80×25mm	Yes	✓	✓	✓	111
109R0824M4011	109R0824M4021	109R0824M4011	109R0824M4D011	—	80×80×25mm	No	✓	✓	✓	111
109R0824S401	109R0824S402	109R0824S401	109R0824S4D01	—	80×80×25mm	Yes	✓	✓	✓	111
109R0824S4011	109R0824S4021	109R0824S4011	109R0824S4D011	—	80×80×25mm	No	✓	✓	✓	111
109R0848K401	109R0848K402	109R0848K401	109R0848K4D01	—	80×80×25mm	Yes	✓	✓	✓	111
109R0848K4011	109R0848K4021	109R0848K4011	109R0848K4D011	—	80×80×25mm	No	✓	✓	✓	111
109R0848S401	109R0848S402	109R0848S401	109R0848S4D01	—	80×80×25mm	Yes	✓	✓	✓	111
109R0848S4011	109R0848S4021	109R0848S4011	109R0848S4D011	—	80×80×25mm	No	✓	✓	✓	111
109W1412H101-U	109W1412H102-U	109W1412H101-U	—	—	140×140×38mm	No	✓	✓	✓	285
109W1412M101-U	109W1412M102-U	109W1412M101-U	109W1412M1D01-U	—	140×140×38mm	No	✓	✓	✓	285
109W1424H101-U	109W1424H102-U	109W1424H101-U	—	—	140×140×38mm	No	✓	✓	✓	285
109W1424M101-U	109W1424M102-U	109W1424M101-U	—	—	140×140×38mm	No	✓	✓	✓	285
109W1448H101-U	109W1448H102-U	109W1448H101-U	109W1448H1D01-U	—	140×140×38mm	No	✓	✓	✓	285
109W1448M101-U	109W1448M102-U	109W1448M101-U	—	—	140×140×38mm	No	✓	✓	✓	285
9A0612F401	9A0612F402	9A0612F401	9A0612F4D01	—	60×60×25mm	Yes	✓	✓	✓	75
9A0612F4011	9A0612F4021	9A0612F4011	9A0612F4D011	—	60×60×25mm	No	✓	✓	✓	75
9A0612G401	9A0612G402	9A0612G401	9A0612G4D01	9AH0612P4G03	60×60×25mm	Yes	✓	✓	✓	75
9A0612G4011	9A0612G4021	9A0612G4011	9A0612G4D011	—	60×60×25mm	No	✓	✓	✓	75
9A0612H401	9A0612H402	9A0612H401	9A0612H4D01	9AH0612P4H05	60×60×25mm	Yes	✓	✓	✓	75
9A0612H4011	9A0612H4021	9A0612H4011	9A0612H4D011	—	60×60×25mm	No	✓	✓	✓	75
9A0612M401	9A0612M402	9A0612M401	9A0612M4D01	—	60×60×25mm	Yes	✓	✓	✓	75
9A0612M4011	9A0612M4021	9A0612M4011	9A0612M4D011	—	60×60×25mm	No	✓	✓	✓	75
9A0612S401	9A0612S402	9A0612S401	9A0612S4D01	—	60×60×25mm	Yes	✓	✓	✓	75
9A0612S4011	9A0612S4021	9A0612S4011	9A0612S4D011	—	60×60×25mm	No	✓	✓	✓	75
9A0624F401	9A0624F402	9A0624F401	9A0624F4D01	—	60×60×25mm	Yes	✓	✓	✓	75
9A0624F4011	9A0624F4021	9A0624F4011	9A0624F4D011	—	60×60×25mm	No	✓	✓	✓	75
9A0624G401	9A0624G402	9A0624G401	9A0624G4D01	—	60×60×25mm	Yes	✓	✓	✓	75
9A0624G4011	9A0624G4021	9A0624G4011	—	—	60×60×25mm	No	✓	✓	✓	75
9A0624H401	9A0624H402	9A0624H401	9A0624H4D01	—	60×60×25mm	Yes	✓	✓	✓	75
9A0624H4011	9A0624H4021	9A0624H4011	9A0624H4D011	—	60×60×25mm	No	✓	✓	✓	75
9A0624M401	9A0624M402	9A0624M401	9A0624M4D01	—	60×60×25mm	Yes	✓	✓	✓	75
9A0624M4011	9A0624M4021	9A0624M4011	9A0624M4D011	—	60×60×25mm	No	✓	✓	✓	75
9A0624S401	9A0624S402	9A0624S401	9A0624S4D01	—	60×60×25mm	Yes	✓	✓	✓	75

Models listed in the main section of this catalog	List of models (models not listed in the main section of this catalog are options. Standards for optional model numbers may differ from the certified standards listed at right. Contact us for details of models with "-" model numbers.)				Frame Size	Rib	Standard (certification status is for the models listed in this catalog, and standards for optional model numbers may differ.)			page
	Without sensor	With pulse sensor	With lock sensor	With PWM control function and pulse sensor			UL (cUL)	CSA (cUL)	TÜV	
							✓	✓	✓	
9A0624S4011	9A0624S4021	9A0624S4011	9A0624S4D011	—	60×60×25mm	No	✓	✓	✓	75
9A0812F401	9A0812F402	9A0812F401	9A0812F4D01	—	80×80×25mm	Yes	✓	✓	✓	115
9A0812F4011	9A0812F4021	9A0812F4011	9A0812F4D011	—	80×80×25mm	No	✓	✓	✓	115
9A0812G401	9A0812G402	9A0812G401	9A0812G4D01	9AH0812P4G04	80×80×25mm	Yes	✓	✓	✓	115
9A0812G4011	9A0812G4021	9A0812G4011	9A0812G4D011	9AH0812P4G011	80×80×25mm	No	✓	✓	✓	115
9A0812H401	9A0812H402	9A0812H401	9A0812H4D01	9AH0812P4H04	80×80×25mm	Yes	✓	✓	✓	115
9A0812H4011	9A0812H4021	9A0812H4011	9A0812H4D011	—	80×80×25mm	No	✓	✓	✓	115
9A0812L401	9A0812L402	9A0812L401	9A0812L4D01	—	80×80×25mm	Yes	✓	✓	✓	115
9A0812L4011	9A0812L4021	9A0812L4011	9A0812L4D011	—	80×80×25mm	No	✓	✓	✓	115
9A0812M401	9A0812M402	9A0812M401	9A0812M4D01	—	80×80×25mm	Yes	✓	✓	✓	115
9A0812M4011	9A0812M4021	9A0812M4011	9A0812M4D011	—	80×80×25mm	No	✓	✓	✓	115
9A0812S401	9A0812S402	9A0812S401	9A0812S4D01	—	80×80×25mm	Yes	✓	✓	✓	115
9A0812S4011	9A0812S4021	9A0812S4011	9A0812S4D011	—	80×80×25mm	No	✓	✓	✓	115
9A0824F401	9A0824F402	9A0824F401	9A0824F4D01	—	80×80×25mm	Yes	✓	✓	✓	115
9A0824F4011	9A0824F4021	9A0824F4011	9A0824F4D011	—	80×80×25mm	No	✓	✓	✓	115
9A0824G401	9A0824G402	9A0824G401	9A0824G4D01	—	80×80×25mm	Yes	✓	✓	✓	115
9A0824G4011	9A0824G4021	9A0824G4011	9A0824G4D011	—	80×80×25mm	No	✓	✓	✓	115
9A0824H401	9A0824H402	9A0824H401	9A0824H4D01	—	80×80×25mm	Yes	✓	✓	✓	115
9A0824H4011	9A0824H4021	9A0824H4011	9A0824H4D011	—	80×80×25mm	No	✓	✓	✓	115
9A0824L401	9A0824L402	9A0824L401	9A0824L4D01	—	80×80×25mm	Yes	✓	✓	✓	115
9A0824L4011	9A0824L4021	9A0824L4011	9A0824L4D011	—	80×80×25mm	No	✓	✓	✓	115
9A0824M401	9A0824M402	9A0824M401	9A0824M4D01	—	80×80×25mm	Yes	✓	✓	✓	115
9A0824M4011	9A0824M4021	9A0824M4011	9A0824M4D011	—	80×80×25mm	No	✓	✓	✓	115
9A0824S401	9A0824S402	9A0824S401	9A0824S4D01	—	80×80×25mm	Yes	✓	✓	✓	115
9A0824S4011	9A0824S4021	9A0824S4011	9A0824S4D011	—	80×80×25mm	No	✓	✓	✓	115
9A0912F401	9A0912F402	9A0912F401	9A0912F4D01	—	92×92×25mm	Yes	✓	✓	✓	143
9A0912F4011	9A0912F4021	9A0912F4011	9A0912F4D011	—	92×92×25mm	No	✓	✓	✓	143
9A0912G401	9A0912G402	9A0912G401	9A0912G4D01	9AH0912P4G03	92×92×25mm	Yes	✓	✓	✓	143
9A0912G4011	9A0912G4021	9A0912G4011	9A0912G4D011	—	92×92×25mm	No	✓	✓	✓	143
9A0912H401	9A0912H402	9A0912H401	9A0912H4D01	9AH0912P4H03	92×92×25mm	Yes	✓	✓	✓	143
9A0912H4011	9A0912H4021	9A0912H4011	9A0912H4D011	—	92×92×25mm	No	✓	✓	✓	143
9A0912L401	9A0912L402	9A0912L401	9A0912L4D01	—	92×92×25mm	Yes	✓	✓	✓	143
9A0912L4011	9A0912L4021	9A0912L4011	9A0912L4D011	—	92×92×25mm	No	✓	✓	✓	143
9A0912M401	9A0912M402	9A0912M401	9A0912M4D01	—	92×92×25mm	Yes	✓	✓	✓	143
9A0912M4011	9A0912M4021	9A0912M4011	9A0912M4D011	—	92×92×25mm	No	✓	✓	✓	143
9A0912S401	9A0912S402	9A0912S401	9A0912S4D01	—	92×92×25mm	Yes	✓	✓	✓	143
9A0912S4011	9A0912S4021	9A0912S4011	9A0912S4D011	—	92×92×25mm	No	✓	✓	✓	143
9A0924F401	9A0924F402	9A0924F401	9A0924F4D01	—	92×92×25mm	Yes	✓	✓	✓	143
9A0924F4011	9A0924F4021	9A0924F4011	9A0924F4D011	—	92×92×25mm	No	✓	✓	✓	143
9A0924G401	9A0924G402	9A0924G401	9A0924G4D01	—	92×92×25mm	Yes	✓	✓	✓	143
9A0924G4011	9A0924G4021	9A0924G4011	—	—	92×92×25mm	No	✓	✓	✓	143
9A0924H401	9A0924H402	9A0924H401	9A0924H4D01	—	92×92×25mm	Yes	✓	✓	✓	143
9A0924H4011	9A0924H4021	9A0924H4011	9A0924H4D011	—	92×92×25mm	No	✓	✓	✓	143
9A0924L401	9A0924L402	9A0924L401	9A0924L4D01	—	92×92×25mm	Yes	✓	✓	✓	143
9A0924L4011	9A0924L4021	9A0924L4011	9A0924L4D011	—	92×92×25mm	No	✓	✓	✓	143
9A0924M401	9A0924M402	9A0924M401	9A0924M4D01	—	92×92×25mm	Yes	✓	✓	✓	143
9A0924M4011	9A0924M4021	9A0924M4011	9A0924M4D011	—	92×92×25mm	No	✓	✓	✓	143
9A0924S401	9A0924S402	9A0924S401	9A0924S4D01	—	92×92×25mm	Yes	✓	✓	✓	143
9A0924S4011	9A0924S4021	9A0924S4011	9A0924S4D011	—	92×92×25mm	No	✓	✓	✓	143
9A0948S401	9A0948S402	9A0948S401	9A0948S4D01	—	92×92×25mm	Yes	✓	✓	✓	143
9A0948S4011	9A0948S4021	9A0948S4011	—	—	92×92×25mm	No	✓	✓	✓	143
9B1TP24P0H001	—	—	—	9B1TP24P0H001	φ270mm×99mm	—	✓	✓	✓	387
9B1TP48P0H001	—	—	—	9B1TP48P0H001	φ270mm×99mm	—	✓	✓	✓	387
9B1TP48P0G001	—	—	—	9B1TP48P0G001	φ270mm×99mm	—	✓	✓	✓	387
9B1TS48P0H001	—	—	—	9B1TS48P0H001	φ270mm×119mm	—	✓	✓	✓	389
9B1TS48P0G001	—	—	—	9B1TS48P0G001	φ270mm×119mm	—	✓	✓	✓	389
9BD12FC6-1	9BD12FA6-1	9BD12FC6-1	9BD12FD6-1	—	76mm×20mm	—	✓	✓	✓	395
9BD12HC6-1	9BD12HA6-1	9BD12HC6-1	9BD12HD6-1	—	76mm×20mm	—	✓	✓	✓	395
9BD12SC6-1	9BD12SA6-1	9BD12SC6-1	9BD12SD6-1	9BD12P6S01	76mm×20mm	—	✓	✓	✓	395
9BD24FC6-1	9BD24FA6-1	9BD24FC6-1	9BD24FD6-1	—	76mm×20mm	—	✓	✓	✓	395
9BD24HC6-1	9BD24HA6-1	9BD24HC6-1	9BD24HD6-1	—	76mm×20mm	—	✓	✓	✓	395
9BD24SC6-1	9BD24SA6-1	9BD24SC6-1	9BD24SD6-1	9BD24P6S06	76mm×20mm	—	✓	✓	✓	395

Models listed in the main section of this catalog	List of models (models not listed in the main section of this catalog are options. Standards for optional model numbers may differ from the certified standards listed at right. Contact us for details of models with "-" model numbers.)				Frame Size	Rib	Standard (certification status is for the models listed in this catalog, and standards for optional model numbers may differ.)			page
	Without sensor	With pulse sensor	With lock sensor	With PWM control function and pulse sensor			UL (cUL)	CSA (cUL)	TUV	
9BFB12P2H003	—	—	—	9BFB12P2H003	120mm×32mm	—	✓	✓	✓	407
9BFB24P2H003	—	—	—	9BFB24P2H003	120mm×32mm	—	✓	✓	✓	407
9BMB12F201	9BMB12F202	9BMB12F201	9BMB12F2D01	9BMB12P2F01	97mm×33mm	—	✓	✓	✓	401
9BMB12G201	9BMB12G202	9BMB12G201	9BMB12G2D01	9BMB12P2G01	97mm×33mm	—	✓	✓	✓	401
9BMB12H201	9BMB12H202	9BMB12H201	9BMB12H2D01	9BMB12P2H01	97mm×33mm	—	✓	✓	✓	401
9BMB12K201	9BMB12K202	9BMB12K201	—	9BMB12P2K01	97mm×33mm	—	✓	✓	✓	401
9BMB12P2F01	9BMB12F202	9BMB12F201	9BMB12F2D01	9BMB12P2F01	97mm×33mm	—	✓	✓	✓	401
9BMB12P2G01	9BMB12G202	9BMB12G201	9BMB12G2D01	9BMB12P2G01	97mm×33mm	—	✓	✓	✓	401
9BMB12P2H01	9BMB12H202	9BMB12H201	9BMB12H2D01	9BMB12P2H01	97mm×33mm	—	✓	✓	✓	401
9BMB12P2K01	9BMB12K202	9BMB12K201	—	9BMB12P2K01	97mm×33mm	—	✓	✓	✓	401
9BMB12P2S01	9BMB12S202	9BMB12S201	—	9BMB12P2S01	97mm×33mm	—	✓	✓	✓	401
9BMB12S201	9BMB12S202	9BMB12S201	—	9BMB12P2S01	97mm×33mm	—	✓	✓	✓	401
9BMB24F201	9BMB24F202	9BMB24F201	9BMB24F2D01	9BMB24P2F01	97mm×33mm	—	✓	✓	✓	401
9BMB24G201	9BMB24G202	9BMB24G201	9BMB24G2D01	9BMB24P2G01	97mm×33mm	—	✓	✓	✓	401
9BMB24H201	9BMB24H202	9BMB24H201	9BMB24H2D01	9BMB24P2H01	97mm×33mm	—	✓	✓	✓	401
9BMB24K201	9BMB24K202	9BMB24K201	—	9BMB24P2K01	97mm×33mm	—	✓	✓	✓	401
9BMB24P2F01	9BMB24F202	9BMB24F201	9BMB24F2D01	9BMB24P2F01	97mm×33mm	—	✓	✓	✓	401
9BMB24P2G01	9BMB24G202	9BMB24G201	9BMB24G2D01	9BMB24P2G01	97mm×33mm	—	✓	✓	✓	401
9BMB24P2H01	9BMB24H202	9BMB24H201	9BMB24H2D01	9BMB24P2H01	97mm×33mm	—	✓	✓	✓	401
9BMB24P2K01	9BMB24K202	9BMB24K201	—	9BMB24P2K01	97mm×33mm	—	✓	✓	✓	401
9BMB24P2S01	9BMB24S202	9BMB24S201	—	9BMB24P2S01	97mm×33mm	—	✓	✓	✓	401
9BMB24S201	9BMB24S202	9BMB24S201	—	9BMB24P2S01	97mm×33mm	—	✓	✓	✓	401
9CR0612P5G03	9CR0612G502	9CR0612G501	—	9CR0612P5G03	60×60×51mm	—	✓	✓	✓	221
9CR0612P5H03	—	9CR0612H501	—	9CR0612P5H03	60×60×51mm	—	✓	✓	✓	221
9CR1212P0G03	9CR1212G002	9CR1212G001	—	9CR1212P0G03	120×120×76mm	—	✓	✓	✓	237
9CR5748P9G001	—	—	—	9CR5748P9G001	φ172mm×150mm×102mm	—	✓	✓	✓	239
9CRA0312P4J03	—	9CRA0312J401	—	9CRA0312P4J03	38×38×48mm	—	✓	✓	✓	209
9CRA0312P4K03	9CRA0312K402	—	—	9CRA0312P4K03	38×38×48mm	—	✓	✓	✓	209
9CRA0412P4G03	9CRA0412G402	—	—	9CRA0412P4G03	40×40×48mm	—	✓	✓	✓	211
9CRA0412P4J03	9CRA0412J402	9CRA0412J401	—	9CRA0412P4J03	40×40×48mm	—	✓	✓	✓	211
9CRA0412P4K03	9CRA0412K402	9CRA0412K401	—	9CRA0412P4K03	40×40×48mm	—	✓	✓	✓	211
9CRA0612P0G001	—	—	—	9CRA0612P0G001	60×60×76mm	—	✓	✓	✓	227
9CRA0612P0S001	—	—	—	9CRA0612P0S001	60×60×76mm	—	✓	✓	✓	227
9CRA0612P6G001	—	—	—	9CRA0612P6G001	60×60×56mm	—	✓	✓	✓	223
9CRA0612P6J001	—	—	—	9CRA0612P6J001	60×60×56mm	—	✓	✓	✓	223
9CRA0612P6K001	—	—	—	9CRA0612P6K001	60×60×56mm	—	✓	✓	✓	223
9CRA0812P8G001	—	9CRA0812G8001	—	9CRA0812P8G001	80×80×80mm	—	✓	✓	✓	233
9CRA0824P8G001	—	—	—	9CRA0824P8G001	80×80×80mm	—	✓	✓	✓	233
9CRA0848P8G001	—	—	—	9CRA0848P8G001	80×80×80mm	—	✓	✓	✓	233
9CRA0912P0G001	—	—	—	9CRA0912P0G001	92×92×76mm	—	✓	✓	✓	235
9CRA0948P0G601	—	—	—	9CRA0948P0G601	92×92×76mm	—	✓	✓	✓	235
9CRB0412P5J201	—	—	—	9CRB0412P5J201	40×40×56mm	—	✓	✓	✓	213
9CRB0412P5K001	—	—	—	9CRB0412P5K001	40×40×56mm	—	✓	✓	✓	213
9CRB0412P5S201	—	—	—	9CRB0412P5S201	40×40×56mm	—	✓	✓	✓	213
9CRB0812P8G001	—	—	—	9CRB0812P8G001	80×80×80mm	—	✓	✓	✓	229
9CRD0412P5G03	—	—	—	9CRD0412P5G03	40×40×56mm	—	✓	✓	✓	215
9CRD0412P5H03	—	—	—	9CRD0412P5H03	40×40×56mm	—	✓	✓	✓	215
9CRD0412P5J03	—	—	—	9CRD0412P5J03	40×40×56mm	—	✓	✓	✓	215
9CRD0412P5M03	—	—	—	9CRD0412P5M03	40×40×56mm	—	✓	✓	✓	215
9CRE0412P5J03	9CRE0412J502	—	—	9CRE0412P5J03	40×40×56mm	—	✓	✓	✓	219
9CRE0612P0G001	—	—	—	9CRE0612P0G001	60×60×76mm	—	✓	✓	✓	225
9CRE0812P8G001	—	—	—	9CRE0812P8G001	80×80×80mm	—	✓	✓	✓	231
9CRL0612P0G001	—	—	—	9CRL0612P0G001	60×60×76mm	No	✓	✓	✓	327
9CRL0812P8G001	—	—	—	9CRL0812P8G001	80×80×80mm	No	✓	✓	✓	333
9EC2024H001	9EC2024H002	9EC2024H001	9EC2024H0D01	—	φ200mm×70mm	No	✓	✓	✓	205
9EC2048A001	9EC2048A002	9EC2048A001	9EC2048A0D01	9EC2048P0A01	φ200mm×70mm	No	✓	✓	✓	205
9EC2048H001	9EC2048H002	9EC2048H001	—	—	φ200mm×70mm	No	✓	✓	✓	205
9EC2048J001	9EC2048J002	9EC2048J001	—	9EC2048P0J01	φ200mm×70mm	No	—	—	—	205
9G0612G101	9G0612G102	9G0612G101	9G0612G1D01	9G0612P1G03	60×60×38mm	Yes	✓	✓	✓	87
9G0612G1011	9G0612G1021	9G0612G1011	9G0612G1D011	9G0612P1G011	60×60×38mm	No	✓	✓	✓	87
9G0612P4H001	9G0612H4002	—	9G0612H4D001	9G0612P4H001	60×60×25mm	Yes	✓	✓	✓	69
9G0612P4H0011	9G0612H40021	9G0612H40011	—	9G0612P4H0011	60×60×25mm	No	✓	✓	✓	69

Models listed in the main section of this catalog	List of models (models not listed in the main section of this catalog are options. Standards for optional model numbers may differ from the certified standards listed at right. Contact us for details of models with "-" model numbers.)				Frame Size	Rib	Standard (certification status is for the models listed in this catalog, and standards for optional model numbers may differ.)			page
	Without sensor	With pulse sensor	With lock sensor	With PWM control function and pulse sensor			UL (cUL)	CSA (cUL)	TÜV	
9G0612P4S001	9G0612S4002	9G0612S4001	—	9G0612P4S001	60×60×25mm	Yes	✓	✓	✓	69
9G0612P4S0011	9G0612S40021	—	—	9G0612P4S0011	60×60×25mm	No	✓	✓	✓	69
9G0612S101	9G0612S102	9G0612S101	9G0612S1D01	—	60×60×38mm	Yes	✓	✓	✓	87
9G0612S1011	9G0612S1021	9G0612S1011	—	—	60×60×38mm	No	✓	✓	✓	87
9G0624G101	9G0624G102	9G0624G101	9G0624G1D01	9G0624P1G03	60×60×38mm	Yes	✓	✓	✓	87
9G0624G1011	9G0624G1021	9G0624G1011	9G0624G1D011	9G0624P1G031	60×60×38mm	No	✓	✓	✓	87
9G0624H101	9G0624H102	9G0624H101	9G0624H1D01	—	60×60×38mm	Yes	✓	✓	✓	87
9G0624H1011	9G0624H1021	9G0624H1011	—	—	60×60×38mm	No	✓	✓	✓	87
9G0624P4H001	9G0624H4002	9G0624H4001	9G0624H4D001	9G0624P4H001	60×60×25mm	Yes	✓	✓	✓	69
9G0624P4H0011	9G0624H40021	—	—	9G0624P4H0011	60×60×25mm	No	✓	✓	✓	69
9G0624P4S001	9G0624S4002	—	9G0624S4D001	9G0624P4S001	60×60×25mm	Yes	✓	✓	✓	69
9G0624P4S0011	—	—	—	9G0624P4S0011	60×60×25mm	No	✓	✓	✓	69
9G0624S101	9G0624S102	9G0624S101	9G0624S1D01	—	60×60×38mm	Yes	✓	✓	✓	87
9G0624S1011	9G0624S1021	9G0624S1011	—	—	60×60×38mm	No	✓	✓	✓	87
9G0648G101	9G0648G102	9G0648G101	9G0648G1D01	9G0648P1G01	60×60×38mm	Yes	✓	✓	✓	87
9G0648G1011	9G0648G1021	9G0648G1011	—	9G0648P1G011	60×60×38mm	No	✓	✓	✓	87
9G0648P4S001	—	—	—	9G0648P4S001	60×60×25mm	Yes	✓	✓	✓	69
9G0648P4S0011	—	—	—	9G0648P4S0011	60×60×25mm	No	✓	✓	✓	69
9G0648S101	9G0648S102	9G0648S101	9G0648S1D01	—	60×60×38mm	Yes	✓	✓	✓	87
9G0648S1011	9G0648S1021	9G0648S1011	—	—	60×60×38mm	No	✓	✓	✓	87
9G0812G101	9G0812G102	9G0812G101	9G0812G1D01	9G0812P1G04	80×80×38mm	Yes	✓	✓	✓	135
9G0812G1011	9G0812G1021	9G0812G1011	9G0812G1D011	9G0812P1G081	80×80×38mm	No	✓	✓	✓	135
9G0812H101	9G0812H102	9G0812H101	9G0812H1D01	9G0812P1H03	80×80×38mm	Yes	✓	✓	✓	135
9G0812H1011	9G0812H1021	9G0812H1011	9G0812H1D011	9G0812P1H051	80×80×38mm	No	✓	✓	✓	135
9G0812K101	9G0812K102	9G0812K101	9G0812K1D01	9G0812P1K08	80×80×38mm	Yes	✓	✓	✓	135
9G0812K1011	9G0812K1021	9G0812K1011	—	9G0812P1K081	80×80×38mm	No	✓	✓	✓	135
9G0824G101	9G0824G102	9G0824G101	9G0824G1D01	9G0824P1G04	80×80×38mm	Yes	✓	✓	✓	135
9G0824G1011	9G0824G1021	9G0824G1011	9G0824G1D011	—	80×80×38mm	No	✓	✓	✓	135
9G0824H101	9G0824H102	9G0824H101	9G0824H1D01	—	80×80×38mm	Yes	✓	✓	✓	135
9G0824H1011	9G0824H1021	9G0824H1011	9G0824H1D011	—	80×80×38mm	No	✓	✓	✓	135
9G0848G101	9G0848G102	9G0848G101	9G0848G1D01	9G0848P1G03	80×80×38mm	Yes	✓	✓	✓	135
9G0848G1011	9G0848G1021	9G0848G1011	9G0848G1D011	—	80×80×38mm	No	✓	✓	✓	135
9G0848H101	9G0848H102	9G0848H101	9G0848H1D01	9G0848P1H04	80×80×38mm	Yes	✓	✓	✓	135
9G0848H1011	9G0848H1021	9G0848H1011	—	—	80×80×38mm	No	✓	✓	✓	135
9G0912A201	9G0912A202	9G0912A201	9G0912A2D01	—	92×92×32mm	Yes	✓	✓	✓	145
9G0912A2011	9G0912A2021	9G0912A2011	9G0912A2D011	—	92×92×32mm	No	✓	✓	✓	145
9G0912G101	9G0912G102	9G0912G101	9G0912G1D01	9G0912P1G03	92×92×38mm	Yes	✓	✓	✓	155
9G0912G1011	9G0912G1021	9G0912G1011	—	9G0912P1G031	92×92×38mm	No	✓	✓	✓	155
9G0912H101	9G0912H102	9G0912H101	9G0912H1D01	9G0912P1H05	92×92×38mm	Yes	✓	✓	✓	155
9G0912H1011	9G0912H1021	9G0912H1011	9G0912H1D011	—	92×92×38mm	No	✓	✓	✓	155
9G0912H201	9G0912H202	9G0912H201	9G0912H2D01	9G0912P2H01	92×92×32mm	Yes	✓	✓	✓	145
9G0912H2011	9G0912H2021	9G0912H2011	9G0912H2D011	—	92×92×32mm	No	✓	✓	✓	145
9G0912M201	9G0912M202	9G0912M201	9G0912M2D01	—	92×92×32mm	Yes	✓	✓	✓	145
9G0912M2011	9G0912M2021	9G0912M2011	9G0912M2D011	—	92×92×32mm	No	✓	✓	✓	145
9G0912S201	9G0912S202	9G0912S201	9G0912S2D01	9G0912P2S01	92×92×32mm	Yes	✓	✓	✓	145
9G0912S2011	9G0912S2021	9G0912S2011	9G0912S2D011	—	92×92×32mm	No	✓	✓	✓	145
9G0924A201	9G0924A202	9G0924A201	9G0924A2D01	—	92×92×32mm	Yes	✓	✓	✓	145
9G0924A2011	9G0924A2021	9G0924A2011	9G0924A2D011	—	92×92×32mm	No	✓	✓	✓	145
9G0924G101	9G0924G102	9G0924G101	9G0924G1D01	—	92×92×38mm	Yes	✓	✓	✓	155
9G0924G1011	9G0924G1021	9G0924G1011	9G0924G1D011	—	92×92×38mm	No	✓	✓	✓	155
9G0924H101	9G0924H102	9G0924H101	9G0924H1D01	—	92×92×38mm	Yes	✓	✓	✓	155
9G0924H1011	9G0924H1021	9G0924H1011	9G0924H1D011	—	92×92×38mm	No	✓	✓	✓	155
9G0924H201	9G0924H202	9G0924H201	9G0924H2D01	—	92×92×32mm	Yes	✓	✓	✓	145
9G0924H2011	9G0924H2021	9G0924H2011	9G0924H2D011	—	92×92×32mm	No	✓	✓	✓	145
9G0924M201	9G0924M202	9G0924M201	9G0924M2D01	—	92×92×32mm	Yes	✓	✓	✓	145
9G0924M2011	9G0924M2021	9G0924M2011	9G0924M2D011	—	92×92×32mm	No	✓	✓	✓	145
9G0924S201	9G0924S202	9G0924S201	9G0924S2D01	—	92×92×32mm	Yes	✓	✓	✓	145
9G0924S2011	9G0924S2021	9G0924S2011	9G0924S2D011	—	92×92×32mm	No	✓	✓	✓	145
9G0948A201	9G0948A202	9G0948A201	9G0948A2D01	—	92×92×32mm	Yes	✓	✓	✓	145
9G0948A2011	9G0948A2021	9G0948A2011	9G0948A2D011	—	92×92×32mm	No	✓	✓	✓	145
9G0948G101	9G0948G102	9G0948G101	9G0948G1D01	—	92×92×38mm	Yes	✓	✓	✓	155
9G0948G1011	9G0948G1021	9G0948G1011	—	—	92×92×38mm	No	✓	✓	✓	155

Models listed in the main section of this catalog	List of models (models not listed in the main section of this catalog are options. Standards for optional model numbers may differ from the certified standards listed at right. Contact us for details of models with "-" model numbers.)				Frame Size	Rib	Standard (certification status is for the models listed in this catalog, and standards for optional model numbers may differ.)			page
	Without sensor	With pulse sensor	With lock sensor	With PWM control function and pulse sensor			UL (cUL)	CSA (cUL)	TÜV	
	9G0948H101	9G0948H102	9G0948H101	9G0948H1D01			—	92×92×38mm	Yes	
9G0948H1011	—	9G0948H1011	—	—	92×92×38mm	No	✓	✓	✓	155
9G0948H201	9G0948H202	9G0948H201	9G0948H2D01	—	92×92×32mm	Yes	✓	✓	✓	145
9G0948H2011	9G0948H2021	9G0948H2011	9G0948H2D011	—	92×92×32mm	No	✓	✓	✓	145
9G0948J101	—	9G0948J101	—	—	92×92×38mm	Yes	✓	✓	✓	155
9G0948J1011	—	9G0948J1011	—	9G0948P1J031	92×92×38mm	No	✓	✓	✓	155
9G0948M201	9G0948M202	9G0948M201	9G0948M2D01	—	92×92×32mm	Yes	✓	✓	✓	145
9G0948M2011	9G0948M2021	9G0948M2011	9G0948M2D011	—	92×92×32mm	No	✓	✓	✓	145
9G0948S201	9G0948S202	9G0948S201	9G0948S2D01	—	92×92×32mm	Yes	✓	✓	✓	145
9G0948S2011	9G0948S2021	9G0948S2011	9G0948S2D011	—	92×92×32mm	No	✓	✓	✓	145
9G1212A401	9G1212A402	9G1212A401	9G1212A4D01	—	120×120×25mm	Yes	✓	✓	✓	163
9G1212A4011	9G1212A4021	9G1212A4011	9G1212A4D011	—	120×120×25mm	No	✓	✓	✓	163
9G1212B401	—	9G1212B401	—	—	120×120×25mm	Yes	—	—	—	163
9G1212B4011	—	9G1212B4011	—	—	120×120×25mm	No	—	—	—	163
9G1212E101	9G1212E102	9G1212E101	9G1212E1D01	—	120×120×38mm	Yes	✓	✓	✓	173
9G1212E1011	9G1212E1021	9G1212E1011	9G1212E1D011	—	120×120×38mm	No	✓	✓	✓	173
9G1212E401	9G1212E402	9G1212E401	9G1212E4D01	9G1212P4E05	120×120×25mm	Yes	✓	✓	✓	163
9G1212E4011	9G1212E4021	9G1212E4011	9G1212E4D011	9G1212P4E041	120×120×25mm	No	✓	✓	✓	163
9G1212F101	9G1212F102	9G1212F101	—	—	120×120×38mm	Yes	✓	✓	✓	173
9G1212F1011	9G1212F1021	9G1212F1011	—	—	120×120×38mm	No	✓	✓	✓	173
9G1212F401	9G1212F402	9G1212F401	9G1212F4D01	—	120×120×25mm	Yes	✓	✓	✓	163
9G1212F4011	9G1212F4021	9G1212F4011	9G1212F4D011	—	120×120×25mm	No	✓	✓	✓	163
9G1212G101	9G1212G102	9G1212G101	9G1212G1D01	9G1212P1G04	120×120×38mm	Yes	✓	✓	✓	173
9G1212G1011	9G1212G1021	9G1212G1011	9G1212G1D011	9G1212P1G081	120×120×38mm	No	✓	✓	✓	173
9G1212G401	9G1212G402	9G1212G401	9G1212G4D01	9G1212P4G03	120×120×25mm	Yes	✓	✓	✓	163
9G1212G4011	9G1212G4021	9G1212G4011	9G1212G4D011	9G1212P4G031	120×120×25mm	No	✓	✓	✓	163
9G1212H101	9G1212H102	9G1212H101	9G1212H1D01	—	120×120×38mm	Yes	✓	✓	✓	173
9G1212H1011	9G1212H1021	9G1212H1011	9G1212H1D011	—	120×120×38mm	No	✓	✓	✓	173
9G1212H401	9G1212H402	9G1212H401	9G1212H4D01	9G1212P4H04	120×120×25mm	Yes	✓	✓	✓	163
9G1212H4011	9G1212H4021	9G1212H4011	9G1212H4D011	9G1212P4H091	120×120×25mm	No	✓	✓	✓	163
9G1212M101	9G1212M102	9G1212M101	9G1212M1D01	—	120×120×38mm	Yes	✓	✓	✓	173
9G1212M1011	9G1212M1021	9G1212M1011	9G1212M1D011	—	120×120×38mm	No	✓	✓	✓	173
9G1212M401	9G1212M402	9G1212M401	9G1212M4D01	—	120×120×25mm	Yes	✓	✓	✓	163
9G1212M4011	9G1212M4021	9G1212M4011	9G1212M4D011	—	120×120×25mm	No	✓	✓	✓	163
9G1224A401	9G1224A402	9G1224A401	9G1224A4D01	—	120×120×25mm	Yes	✓	✓	✓	163
9G1224A4011	9G1224A4021	9G1224A4011	9G1224A4D011	—	120×120×25mm	No	✓	✓	✓	163
9G1224E101	9G1224E102	9G1224E101	9G1224E1D01	—	120×120×38mm	Yes	✓	✓	✓	173
9G1224E1011	9G1224E1021	9G1224E1011	9G1224E1D011	—	120×120×38mm	No	✓	✓	✓	173
9G1224E401	9G1224E402	9G1224E401	9G1224E4D01	9G1224P4E01	120×120×25mm	Yes	✓	✓	✓	163
9G1224E4011	9G1224E4021	9G1224E4011	9G1224E4D011	—	120×120×25mm	No	✓	✓	✓	163
9G1224F101	9G1224F102	9G1224F101	9G1224F1D01	—	120×120×38mm	Yes	✓	✓	✓	173
9G1224F1011	9G1224F1021	9G1224F1011	—	—	120×120×38mm	No	✓	✓	✓	173
9G1224F401	9G1224F402	9G1224F401	9G1224F4D01	—	120×120×25mm	Yes	✓	✓	✓	163
9G1224F4011	9G1224F4021	9G1224F4011	9G1224F4D011	—	120×120×25mm	No	✓	✓	✓	163
9G1224G101	9G1224G102	9G1224G101	9G1224G1D01	9G1224P1G01	120×120×38mm	Yes	✓	✓	✓	173
9G1224G1011	9G1224G1021	9G1224G1011	9G1224G1D011	—	120×120×38mm	No	✓	✓	✓	173
9G1224G401	9G1224G402	9G1224G401	9G1224G4D01	—	120×120×25mm	Yes	✓	✓	✓	163
9G1224G4011	9G1224G4021	9G1224G4011	9G1224G4D011	—	120×120×25mm	No	✓	✓	✓	163
9G1224H101	9G1224H102	9G1224H101	9G1224H1D01	—	120×120×38mm	Yes	✓	✓	✓	173
9G1224H1011	9G1224H1021	9G1224H1011	9G1224H1D011	—	120×120×38mm	No	✓	✓	✓	173
9G1224H401	9G1224H402	9G1224H401	9G1224H4D01	—	120×120×25mm	Yes	✓	✓	✓	163
9G1224H4011	9G1224H4021	9G1224H4011	9G1224H4D011	—	120×120×25mm	No	✓	✓	✓	163
9G1224M101	9G1224M102	9G1224M101	9G1224M1D01	—	120×120×38mm	Yes	✓	✓	✓	173
9G1224M1011	9G1224M1021	9G1224M1011	9G1224M1D011	—	120×120×38mm	No	✓	✓	✓	173
9G1224M401	9G1224M402	9G1224M401	9G1224M4D01	—	120×120×25mm	Yes	✓	✓	✓	163
9G1224M4011	9G1224M4021	9G1224M4011	9G1224M4D011	—	120×120×25mm	No	✓	✓	✓	163
9G1248A401	9G1248A402	9G1248A401	9G1248A4D01	—	120×120×25mm	Yes	✓	✓	✓	163
9G1248A4011	9G1248A4021	9G1248A4011	9G1248A4D011	—	120×120×25mm	No	✓	✓	✓	163
9G1248E101	9G1248E102	9G1248E101	9G1248E1D01	—	120×120×38mm	Yes	✓	✓	✓	173
9G1248E1011	9G1248E1021	9G1248E1011	9G1248E1D011	—	120×120×38mm	No	✓	✓	✓	173
9G1248E401	9G1248E402	9G1248E401	9G1248E4D01	9G1248P4E05	120×120×25mm	Yes	✓	✓	✓	163
9G1248E4011	9G1248E4021	9G1248E4011	9G1248E4D011	—	120×120×25mm	No	✓	✓	✓	163

Models listed in the main section of this catalog	List of models (models not listed in the main section of this catalog are options. Standards for optional model numbers may differ from the certified standards listed at right. Contact us for details of models with "-" model numbers.)				Frame Size	Rib	Standard (certification status is for the models listed in this catalog, and standards for optional model numbers may differ.)			page
	Without sensor	With pulse sensor	With lock sensor	With PWM control function and pulse sensor			UL (cUL)	CSA (cUL)	TÜV	
	9G1248F101	9G1248F102	9G1248F101	9G1248F1D01			—	120×120×38mm	Yes	
9G1248F1011	9G1248F1021	9G1248F1011	—	—	120×120×38mm	No	✓	✓	✓	173
9G1248F401	9G1248F402	9G1248F401	9G1248F4D01	—	120×120×25mm	Yes	✓	✓	✓	163
9G1248F4011	9G1248F4021	9G1248F4011	9G1248F4D011	—	120×120×25mm	No	✓	✓	✓	163
9G1248G101	9G1248G102	9G1248G101	9G1248G1D01	9G1248P1G04	120×120×38mm	Yes	✓	✓	✓	173
9G1248G1011	9G1248G1021	9G1248G1011	9G1248G1D011	9G1248P1G041	120×120×38mm	No	✓	✓	✓	173
9G1248G401	9G1248G402	9G1248G401	9G1248G4D01	9G1248P4G04	120×120×25mm	Yes	✓	✓	✓	163
9G1248G4011	9G1248G4021	9G1248G4011	9G1248G4D011	—	120×120×25mm	No	✓	✓	✓	163
9G1248H101	9G1248H102	9G1248H101	9G1248H1D01	—	120×120×38mm	Yes	✓	✓	✓	173
9G1248H1011	9G1248H1021	9G1248H1011	9G1248H1D011	—	120×120×38mm	No	✓	✓	✓	173
9G1248H401	9G1248H402	9G1248H401	9G1248H4D01	—	120×120×25mm	Yes	✓	✓	✓	163
9G1248H4011	9G1248H4021	9G1248H4011	9G1248H4D011	—	120×120×25mm	No	✓	✓	✓	163
9G1248M101	9G1248M102	9G1248M101	9G1248M1D01	—	120×120×38mm	Yes	✓	✓	✓	173
9G1248M1011	9G1248M1021	9G1248M1011	9G1248M1D011	—	120×120×38mm	No	✓	✓	✓	173
9G1248M401	9G1248M402	9G1248M401	9G1248M4D01	—	120×120×25mm	Yes	✓	✓	✓	163
9G1248M4011	9G1248M4021	9G1248M4011	9G1248M4D011	—	120×120×25mm	No	✓	✓	✓	163
9GA0312P3G001	—	9GA0312G3001	—	9GA0312P3G001	38×38×28mm	Yes	✓	✓	✓	13
9GA0312P3G0011	—	—	—	9GA0312P3G0011	38×38×28mm	No	✓	✓	✓	13
9GA0312P3J001	—	9GA0312J3001	—	9GA0312P3J001	38×38×28mm	Yes	✓	✓	✓	13
9GA0312P3J0011	—	—	—	9GA0312P3J0011	38×38×28mm	No	✓	✓	✓	13
9GA0312P3K001	—	9GA0312K3001	—	9GA0312P3K001	38×38×28mm	Yes	✓	✓	✓	13
9GA0312P3K0011	—	—	—	9GA0312P3K0011	38×38×28mm	No	✓	✓	✓	13
9GA0405P6F001	9GA0405F6002	9GA0405F6001	—	9GA0405P6F001	40×40×20mm	Yes	✓	✓	✓	23
9GA0405P6H001	9GA0405H6002	9GA0405H6001	—	9GA0405P6H001	40×40×20mm	Yes	✓	✓	✓	23
9GA0412G7001	9GA0412G7002	9GA0412G7001	9GA0412G7D001	9GA0412P7G001	40×40×15mm	Yes	✓	✓	✓	19
9GA0412H7001	9GA0412H7002	9GA0412H7001	9GA0412H7D001	—	40×40×15mm	Yes	✓	✓	✓	19
9GA0412P3G01	9GA0412G302	9GA0412G301	—	9GA0412P3G01	40×40×28mm	Yes	✓	✓	✓	35
9GA0412P3G011	9GA0412G3021	9GA0412G3011	—	9GA0412P3G011	40×40×28mm	No	✓	✓	✓	35
9GA0412P3H01	9GA0412H302	9GA0412H301	9GA0412H3D01	9GA0412P3H01	40×40×28mm	Yes	✓	✓	✓	35
9GA0412P3H011	9GA0412H3021	9GA0412H3011	9GA0412H3D011	9GA0412P3H011	40×40×28mm	No	✓	✓	✓	35
9GA0412P3J01	9GA0412J302	9GA0412J301	9GA0412J3D01	9GA0412P3J01	40×40×28mm	Yes	✓	✓	✓	35
9GA0412P3J011	9GA0412J3021	9GA0412J3011	—	9GA0412P3J011	40×40×28mm	No	✓	✓	✓	35
9GA0412P3K01	9GA0412K302	9GA0412K301	9GA0412K3D01	9GA0412P3K01	40×40×28mm	Yes	✓	✓	✓	35
9GA0412P3K011	9GA0412K3021	9GA0412K3011	—	9GA0412P3K011	40×40×28mm	No	✓	✓	✓	35
9GA0412P3M01	9GA0412M302	9GA0412M301	9GA0412M3D01	9GA0412P3M01	40×40×28mm	Yes	✓	✓	✓	35
9GA0412P3M011	9GA0412M3021	9GA0412M3011	—	9GA0412P3M011	40×40×28mm	No	✓	✓	✓	35
9GA0412P6F001	9GA0412F6002	9GA0412F6001	—	9GA0412P6F001	40×40×20mm	Yes	✓	✓	✓	23
9GA0412P6G001	9GA0412G6002	9GA0412G6001	—	9GA0412P6G001	40×40×20mm	Yes	✓	✓	✓	23
9GA0412P6H001	9GA0412H6002	9GA0412H6001	—	9GA0412P6H001	40×40×20mm	Yes	✓	✓	✓	23
9GA0412P7G001	9GA0412G7002	9GA0412G7001	9GA0412G7D001	9GA0412P7G001	40×40×15mm	Yes	✓	✓	✓	19
9GA0424P3G001	9GA0424G3002	9GA0424G3001	9GA0424G3D001	9GA0424P3G001	40×40×28mm	Yes	✓	✓	✓	35
9GA0424P3G0011	9GA0424G30021	9GA0424G30011	—	9GA0424P3G0011	40×40×28mm	No	✓	✓	✓	35
9GA0424P3H001	9GA0424H3002	9GA0424H3001	9GA0424H3D001	9GA0424P3H001	40×40×28mm	Yes	✓	✓	✓	35
9GA0424P3H0011	9GA0424H30021	9GA0424H30011	—	9GA0424P3H0011	40×40×28mm	No	✓	✓	✓	35
9GA0424P3J001	9GA0424J3002	9GA0424J3001	9GA0424J3D001	9GA0424P3J001	40×40×28mm	Yes	✓	✓	✓	35
9GA0424P3J0011	9GA0424J30021	9GA0424J30011	—	9GA0424P3J0011	40×40×28mm	No	✓	✓	✓	35
9GA0424P3M001	9GA0424M3002	9GA0424M3001	—	9GA0424P3M001	40×40×28mm	Yes	✓	✓	✓	35
9GA0424P3M0011	9GA0424M30021	9GA0424M30011	9GA0424M3D001	9GA0424P3M0011	40×40×28mm	No	✓	✓	✓	35
9GA0424P6F001	9GA0424F6002	9GA0424F6001	—	9GA0424P6F001	40×40×20mm	Yes	✓	✓	✓	23
9GA0424P6G001	9GA0424G6002	9GA0424G6001	9GA0424G6D001	9GA0424P6G001	40×40×20mm	Yes	✓	✓	✓	23
9GA0424P6H001	9GA0424H6002	9GA0424H6001	9GA0424H6D001	9GA0424P6H001	40×40×20mm	Yes	✓	✓	✓	23
9GA0512P7A001	9GA0512A7002	9GA0512A7001	—	9GA0512P7A001	52×52×15mm	Yes	✓	✓	✓	47
9GA0512P7G001	9GA0512G7002	9GA0512G7001	—	9GA0512P7G001	52×52×15mm	Yes	✓	✓	✓	47
9GA0512P7H001	9GA0512H7002	9GA0512H7001	—	9GA0512P7H001	52×52×15mm	Yes	✓	✓	✓	47
9GA0512P7M001	9GA0512M7002	9GA0512M7001	—	9GA0512P7M001	52×52×15mm	Yes	✓	✓	✓	47
9GA0524P7A001	9GA0524A7002	9GA0524A7001	—	9GA0524P7A001	52×52×15mm	Yes	✓	✓	✓	47
9GA0524P7G001	9GA0524G7002	9GA0524G7001	—	9GA0524P7G001	52×52×15mm	Yes	✓	✓	✓	47
9GA0524P7H001	9GA0524H7002	9GA0524H7001	—	9GA0524P7H001	52×52×15mm	Yes	✓	✓	✓	47
9GA0524P7M001	9GA0524M7002	9GA0524M7001	—	9GA0524P7M001	52×52×15mm	Yes	✓	✓	✓	47
9GA0612G701	9GA0612G702	9GA0612G701	9GA0612G7D01	9GA0612P7G01	60×60×15mm	Yes	✓	✓	✓	55
9GA0612G9001	9GA0612G9002	9GA0612G9001	9GA0612G9D001	9GA0612P9G001	60×60×10mm	No	✓	✓	✓	53
9GA0612H6001	9GA0612H6002	9GA0612H6001	9GA0612H6D001	—	60×60×20mm	Yes	✓	✓	✓	61

Please contact your point of sale regarding low-speed sensors.

Models listed in the main section of this catalog	List of models (models not listed in the main section of this catalog are options. Standards for optional model numbers may differ from the certified standards listed at right. Contact us for details of models with "-" model numbers.)				Frame Size	Rib	Standard (certification status is for the models listed in this catalog, and standards for optional model numbers may differ.)			page
	Without sensor	With pulse sensor	With lock sensor	With PWM control function and pulse sensor			UL (cUL)	CSA (cUL)	TÜV	
							✓	✓	✓	
9GA0612H701	9GA0612H702	9GA0612H701	9GA0612H7D01	9GA0612P7H01	60×60×15mm	Yes	✓	✓	✓	55
9GA0612H9001	9GA0612H9002	9GA0612H9001	9GA0612H9D001	—	60×60×10mm	No	✓	✓	✓	53
9GA0612L701	9GA0612L702	9GA0612L701	9GA0612L7D01	—	60×60×15mm	Yes	✓	✓	✓	55
9GA0612L9001	9GA0612L9002	9GA0612L9001	9GA0612L9D001	—	60×60×10mm	No	✓	✓	✓	53
9GA0612M6001	9GA0612M6002	9GA0612M6001	9GA0612M6D001	—	60×60×20mm	Yes	✓	✓	✓	61
9GA0612M701	9GA0612M702	9GA0612M701	—	—	60×60×15mm	Yes	✓	✓	✓	55
9GA0612P1H03	9GA0612H102	9GA0612H101	—	9GA0612P1H03	60×60×38mm	Yes	✓	✓	✓	79
9GA0612P1H031	9GA0612H1021	9GA0612H1011	—	9GA0612P1H031	60×60×38mm	No	✓	✓	✓	79
9GA0612P1J03	9GA0612J102	9GA0612J101	9GA0612J1D01	9GA0612P1J03	60×60×38mm	Yes	✓	✓	✓	79
9GA0612P1J031	9GA0612J1021	9GA0612J1011	—	9GA0612P1J031	60×60×38mm	No	✓	✓	✓	79
9GA0612P1K03	9GA0612K102	9GA0612K101	9GA0612K1D011	9GA0612P1K03	60×60×38mm	Yes	✓	✓	✓	79
9GA0612P1K031	9GA0612K1021	9GA0612K1011	—	9GA0612P1K031	60×60×38mm	No	✓	✓	✓	79
9GA0612P1K60	—	—	—	9GA0612P1K60	60×60×38mm	Yes	✓	✓	✓	79
9GA0612P1K601	—	—	—	9GA0612P1K601	60×60×38mm	No	✓	✓	✓	79
9GA0612P6G001	9GA0612G6002	9GA0612G6001	—	9GA0612P6G001	60×60×20mm	Yes	✓	✓	✓	61
9GA0612P6S001	9GA0612S6002	9GA0612S6001	—	9GA0612P6S001	60×60×20mm	Yes	✓	✓	✓	61
9GA0612P7G01	9GA0612G702	9GA0612G701	9GA0612G7D01	9GA0612P7G01	60×60×15mm	Yes	✓	✓	✓	55
9GA0612P7H01	9GA0612H702	9GA0612H701	9GA0612H7D01	9GA0612P7H01	60×60×15mm	Yes	✓	✓	✓	55
9GA0624H6001	9GA0624H6002	9GA0624H6001	9GA0624H6D001	—	60×60×20mm	Yes	✓	✓	✓	61
9GA0624M6001	9GA0624M6002	9GA0624M6001	9GA0624M6D001	—	60×60×20mm	Yes	✓	✓	✓	61
9GA0624P1J03	9GA0624J102	9GA0624J101	—	9GA0624P1J03	60×60×38mm	Yes	✓	✓	✓	79
9GA0624P1J031	9GA0624J1021	9GA0624J1011	—	9GA0624P1J031	60×60×38mm	No	✓	✓	✓	79
9GA0624P1K03	—	—	—	9GA0624P1K03	60×60×38mm	Yes	✓	✓	✓	79
9GA0624P1K031	—	—	—	9GA0624P1K031	60×60×38mm	No	✓	✓	✓	79
9GA0624P6G001	9GA0624G6002	—	—	9GA0624P6G001	60×60×20mm	Yes	✓	✓	✓	61
9GA0624P6S001	9GA0624S6002	—	—	9GA0624P6S001	60×60×20mm	Yes	✓	✓	✓	61
9GA0624P7G01	9GA0624G702	—	—	9GA0624P7G01	60×60×15mm	Yes	—	—	✓	55
9GA0712P1G001	—	—	—	9GA0712P1G001	70×70×38mm	Yes	✓	✓	✓	89
9GA0712P1G0011	—	—	—	9GA0712P1G0011	70×70×38mm	No	✓	✓	✓	89
9GA0712P1H001	—	—	—	9GA0712P1H001	70×70×38mm	Yes	✓	✓	✓	89
9GA0712P1H0011	—	—	—	9GA0712P1H0011	70×70×38mm	No	✓	✓	✓	89
9GA0812H7001	—	9GA0812H7001	9GA0812H7D001	—	80×80×15mm	Yes	—	—	—	91
9GA0812P1G61	—	—	—	9GA0812P1G61	80×80×38mm	Yes	✓	✓	✓	127
9GA0812P1G611	—	—	—	9GA0812P1G611	80×80×38mm	No	✓	✓	✓	127
9GA0812P1H61	9GA0812H162	9GA0812H161	9GA0812H1D61	9GA0812P1H61	80×80×38mm	Yes	✓	✓	✓	127
9GA0812P1H611	9GA0812H1621	9GA0812H1611	—	9GA0812P1H611	80×80×38mm	No	✓	✓	✓	127
9GA0812P1S61	9GA0812S162	9GA0812S161	9GA0812S1D61	9GA0812P1S61	80×80×38mm	Yes	✓	✓	✓	127
9GA0812P1S611	9GA0812S1621	9GA0812S1611	—	9GA0812P1S611	80×80×38mm	No	✓	✓	✓	127
9GA0812P2H001	—	—	—	9GA0812P2H001	80×80×32mm	Yes	✓	✓	✓	117
9GA0812P2H0011	—	—	—	9GA0812P2H0011	80×80×32mm	No	✓	✓	✓	117
9GA0812P2M001	—	—	—	9GA0812P2M001	80×80×32mm	Yes	✓	✓	✓	117
9GA0812P2M0011	—	—	—	9GA0812P2M0011	80×80×32mm	No	✓	✓	✓	117
9GA0812P2S001	—	9GA0812S2001	—	9GA0812P2S001	80×80×32mm	Yes	✓	✓	✓	117
9GA0812P2S0011	—	—	—	9GA0812P2S0011	80×80×32mm	No	✓	✓	✓	117
9GA0812P4G001	9GA0812G4002	9GA0812G4001	—	9GA0812P4G001	80×80×25mm	Yes	✓	✓	✓	101
9GA0812P4G0011	9GA0812G40021	9GA0812G40011	—	9GA0812P4G0011	80×80×25mm	No	✓	✓	✓	101
9GA0812P4H001	9GA0812H4002	9GA0812H4001	—	9GA0812P4H001	80×80×25mm	Yes	✓	✓	✓	101
9GA0812P4H0011	9GA0812H40021	9GA0812H40011	—	9GA0812P4H0011	80×80×25mm	No	✓	✓	✓	101
9GA0812P4J001	9GA0812J4002	9GA0812J4001	9GA0812J4D001	9GA0812P4J001	80×80×25mm	Yes	✓	✓	✓	101
9GA0812P4J0011	9GA0812J40021	9GA0812J40011	—	9GA0812P4J0011	80×80×25mm	No	✓	✓	✓	101
9GA0812P6G001	9GA0812G6002	9GA0812G6001	—	9GA0812P6G001	80×80×20mm	Yes	✓	✓	✓	97
9GA0812P6M001	9GA0812M6002	9GA0812M6001	—	9GA0812P6M001	80×80×20mm	Yes	✓	✓	✓	97
9GA0812P7G001	—	—	—	9GA0812P7G001	80×80×15mm	Yes	✓	✓	✓	91
9GA0812P7S001	—	—	—	9GA0812P7S001	80×80×15mm	Yes	✓	✓	✓	91
9GA0824H7001	9GA0824H7002	9GA0824H7001	9GA0824H7D001	—	80×80×15mm	Yes	✓	✓	✓	91
9GA0824P1H61	9GA0824H162	9GA0824H161	—	9GA0824P1H61	80×80×38mm	Yes	✓	✓	✓	127
9GA0824P1H611	9GA0824H1621	9GA0824H1611	—	9GA0824P1H611	80×80×38mm	No	✓	✓	✓	127
9GA0824P1S61	9GA0824S162	9GA0824S161	—	9GA0824P1S61	80×80×38mm	Yes	✓	✓	✓	127
9GA0824P1S611	9GA0824S1621	9GA0824S1611	—	9GA0824P1S611	80×80×38mm	No	✓	✓	✓	127
9GA0824P2S001	9GA0824S2002	—	—	9GA0824P2S001	80×80×32mm	Yes	✓	✓	✓	117
9GA0824P2S0011	—	—	—	9GA0824P2S0011	80×80×32mm	No	✓	✓	✓	117
9GA0824P4G001	9GA0824G4002	9GA0824G4001	—	9GA0824P4G001	80×80×25mm	Yes	✓	✓	✓	101

Models listed in the main section of this catalog	List of models (models not listed in the main section of this catalog are options. Standards for optional model numbers may differ from the certified standards listed at right. Contact us for details of models with "-" model numbers.)				Frame Size	Rib	Standard (certification status is for the models listed in this catalog, and standards for optional model numbers may differ.)			page
	Without sensor	With pulse sensor	With lock sensor	With PWM control function and pulse sensor			UL (cUL)	CSA (cUL)	TÜV	
9GA0824P4G0011	9GA0824G40021	9GA0824G40011	—	9GA0824P4G0011	80×80×25mm	No	✓	✓	✓	101
9GA0824P4H001	9GA0824H4002	9GA0824H4001	—	9GA0824P4H001	80×80×25mm	Yes	✓	✓	✓	101
9GA0824P4H0011	9GA0824H40021	9GA0824H40011	—	9GA0824P4H0011	80×80×25mm	No	✓	✓	✓	101
9GA0824P4J001	9GA0824J4002	9GA0824J4001	9GA0824J4D001	9GA0824P4J001	80×80×25mm	Yes	✓	✓	✓	101
9GA0824P4J0011	9GA0824J40021	9GA0824J40011	—	9GA0824P4J0011	80×80×25mm	No	✓	✓	✓	101
9GA0824P6G001	9GA0824G6002	9GA0824G6001	—	9GA0824P6G001	80×80×20mm	Yes	✓	✓	✓	97
9GA0824P6M001	9GA0824M6002	9GA0824M6001	—	9GA0824P6M001	80×80×20mm	Yes	✓	✓	✓	97
9GA0824P7G001	—	—	—	9GA0824P7G001	80×80×15mm	Yes	✓	✓	✓	91
9GA0824P7S001	—	—	—	9GA0824P7S001	80×80×15mm	Yes	✓	✓	✓	91
9GA0848P1S61	—	—	—	9GA0848P1S61	80×80×38mm	Yes	✓	✓	✓	127
9GA0848P1S611	—	—	—	—	80×80×38mm	No	✓	✓	✓	127
9GA0848P2S001	—	—	—	9GA0848P2S001	80×80×32mm	Yes	✓	✓	✓	117
9GA0848P2S0011	—	—	—	—	80×80×32mm	No	✓	✓	✓	117
9GA0912P1H03	9GA0912H102	9GA0912H101	9GA0912H1D01	9GA0912P1H03	92×92×38mm	Yes	✓	✓	✓	147
9GA0912P1H031	9GA0912H1021	9GA0912H1011	—	9GA0912P1H031	92×92×38mm	No	✓	✓	✓	147
9GA0912P4G03	9GA0912G402	9GA0912G401	9GA0912G4D01	9GA0912P4G03	92×92×25mm	Yes	✓	✓	✓	137
9GA0912P4G031	9GA0912G4021	9GA0912G4011	—	9GA0912P4G031	92×92×25mm	No	✓	✓	✓	137
9GA0912P4J03	9GA0912J402	9GA0912J401	9GA0912J4D01	9GA0912P4J03	92×92×25mm	Yes	✓	✓	✓	137
9GA0912P4J031	9GA0912J4021	9GA0912J4011	—	9GA0912P4J031	92×92×25mm	No	✓	✓	✓	137
9GA0912P4S03	9GA0912S402	9GA0912S401	—	9GA0912P4S03	92×92×25mm	Yes	✓	✓	✓	137
9GA0912P4S031	9GA0912S4021	9GA0912S4011	—	9GA0912P4S031	92×92×25mm	No	✓	✓	✓	137
9GA0924P1H01	9GA0924H102	9GA0924H101	9GA0924H1D01	9GA0924P1H01	92×92×38mm	Yes	✓	✓	✓	147
9GA0924P1H011	—	9GA0924H1011	9GA0924H1D011	9GA0924P1H011	92×92×38mm	No	✓	✓	✓	147
9GA0924P4G03	9GA0924G402	9GA0924G401	9GA0924G4D01	9GA0924P4G03	92×92×25mm	Yes	✓	✓	✓	137
9GA0924P4G031	9GA0924G4021	9GA0924G4011	—	9GA0924P4G031	92×92×25mm	No	✓	✓	✓	137
9GA0924P4J03	9GA0924J402	9GA0924J401	9GA0924J4D01	9GA0924P4J03	92×92×25mm	Yes	✓	✓	✓	137
9GA0924P4J031	9GA0924J4021	9GA0924J4011	—	9GA0924P4J031	92×92×25mm	No	✓	✓	✓	137
9GA0924P4S03	9GA0924S402	9GA0924S401	—	9GA0924P4S03	92×92×25mm	Yes	✓	✓	✓	137
9GA0924P4S031	9GA0924S4021	9GA0924S4011	—	9GA0924P4S031	92×92×25mm	No	✓	✓	✓	137
9GA0948P1H03	9GA0948H102	9GA0948H101	—	9GA0948P1H03	92×92×38mm	Yes	✓	✓	✓	147
9GA0948P1H031	—	—	—	9GA0948P1H031	92×92×38mm	No	✓	✓	✓	147
9GAX0412P3K001	—	—	—	9GAX0412P3K001	40×40×28mm	Yes	✓	✓	✓	33
9GAX0412P3K0011	—	—	—	9GAX0412P3K0011	40×40×28mm	No	✓	✓	✓	33
9GAX0412P3K003	—	—	—	9GAX0412P3K003	40×40×28mm	Yes	✓	✓	✓	33
9GAX0412P3K0031	—	—	—	9GAX0412P3K0031	40×40×28mm	No	✓	✓	✓	33
9GAX0412P3S001	—	—	—	9GAX0412P3S001	40×40×28mm	Yes	✓	✓	✓	33
9GAX0412P3S0011	—	—	—	9GAX0412P3S0011	40×40×28mm	No	✓	✓	✓	33
9GAX0412P3S003	—	—	—	9GAX0412P3S003	40×40×28mm	Yes	✓	✓	✓	33
9GAX0412P3S0031	—	—	—	9GAX0412P3S0031	40×40×28mm	No	✓	✓	✓	33
9GE0412P3G03	—	—	9GE0412G3D01	9GE0412P3G03	40×40×28mm	No	✓	✓	✓	39
9GE0412P3J03	—	9GE0412J301	9GE0412J3D01	9GE0412P3J03	40×40×28mm	No	✓	✓	✓	39
9GE0412P3K03	—	9GE0412K301	9GE0412K3D01	9GE0412P3K03	40×40×28mm	No	✓	✓	✓	39
9GL1212E101	9GL1212E102	9GL1212E101	9GL1212E1D01	—	120×120×38mm	No	✓	✓	✓	345
9GL1212F101	9GL1212F102	9GL1212F101	9GL1212F1D01	—	120×120×38mm	No	✓	✓	✓	345
9GL1212G101	9GL1212G102	9GL1212G101	9GL1212G1D01	—	120×120×38mm	No	✓	✓	✓	345
9GL1212H101	9GL1212H102	9GL1212H101	9GL1212H1D01	—	120×120×38mm	No	✓	✓	✓	345
9GL1212M101	9GL1212M102	9GL1212M101	9GL1212M1D01	—	120×120×38mm	No	✓	✓	✓	345
9GL1224E101	9GL1224E102	9GL1224E101	9GL1224E1D01	—	120×120×38mm	No	✓	✓	✓	345
9GL1224F101	9GL1224F102	9GL1224F101	9GL1224F1D01	—	120×120×38mm	No	✓	✓	✓	345
9GL1224G101	9GL1224G102	9GL1224G101	9GL1224G1D01	—	120×120×38mm	No	✓	✓	✓	345
9GL1224H101	9GL1224H102	9GL1224H101	9GL1224H1D01	—	120×120×38mm	No	✓	✓	✓	345
9GL1224M101	9GL1224M102	9GL1224M101	9GL1224M1D01	—	120×120×38mm	No	✓	✓	✓	345
9GL1248E101	9GL1248E102	9GL1248E101	9GL1248E1D01	—	120×120×38mm	No	✓	✓	✓	345
9GL1248F101	9GL1248F102	9GL1248F101	9GL1248F1D01	—	120×120×38mm	No	✓	✓	✓	345
9GL1248G101	9GL1248G102	9GL1248G101	9GL1248G1D01	—	120×120×38mm	No	✓	✓	✓	345
9GL1248H101	9GL1248H102	9GL1248H101	9GL1248H1D01	—	120×120×38mm	No	✓	✓	✓	345
9GL1248M101	9GL1248M102	9GL1248M101	9GL1248M1D01	—	120×120×38mm	No	✓	✓	✓	345
9GT0412P3J001	9GT0412J3002	9GT0412J3001	9GT0412J3D001	9GT0412P3J001	40×40×28mm	No	✓	✓	✓	359
9GT0424P3J001	9GT0424J3002	9GT0424J3001	9GT0424J3D001	9GT0424P3J001	40×40×28mm	No	✓	✓	✓	359
9GT0612P4G001	9GT0612G4002	9GT0612G4001	9GT0612G4D001	9GT0612P4G001	60×60×25mm	No	✓	✓	✓	361
9GT0624P4G001	9GT0624G4002	9GT0624G4001	—	9GT0624P4G001	60×60×25mm	No	✓	✓	✓	361
9GT0812P4S001	9GT0812S4002	9GT0812S4001	9GT0812S4D001	9GT0812P4S001	80×80×25mm	No	✓	✓	✓	363

Please contact your point of sale regarding low-speed sensors.

Models listed in the main section of this catalog	List of models (models not listed in the main section of this catalog are options. Standards for optional model numbers may differ from the certified standards listed at right. Contact us for details of models with "-" model numbers.)				Frame Size	Rib	Standard (certification status is for the models listed in this catalog, and standards for optional model numbers may differ.)			page
	Without sensor	With pulse sensor	With lock sensor	With PWM control function and pulse sensor			UL	CSA	TÜV	
							(cUL)	(cUL)		
9GT0824P4S001	9GT0824S4002	9GT0824S4001	—	9GT0824P4S001	80×80×25mm	No	✓	✓	✓	363
9GT0912P1M001	9GT0912M1002	9GT0912M1001	9GT0912M1D001	9GT0912P1M001	92×92×38mm	No	✓	✓	✓	367
9GT0912P4J001	9GT0912J4002	9GT0912J4001	9GT0912J4D001	9GT0912P4J001	92×92×25mm	No	✓	✓	✓	365
9GT0924P1M001	9GT0924M1002	—	—	9GT0924P1M001	92×92×38mm	No	✓	✓	✓	367
9GT0924P4J001	9GT0924J4002	9GT0924J4001	—	9GT0924P4J001	92×92×25mm	No	✓	✓	✓	365
9GT1212P1S001	—	—	—	9GT1212P1S001	120×120×38mm	No	✓	✓	✓	369
9GT1224P1S001	9GT1224S1002	—	9GT1224S1D001	9GT1224P1S001	120×120×38mm	No	✓	✓	✓	369
9GV0312E301	9GV0312E302	9GV0312E301	9GV0312E3D01	—	38×38×28mm	Yes	✓	✓	✓	15
9GV0312E3011	—	9GV0312E3011	9GV0312E3D011	—	38×38×28mm	No	✓	✓	✓	15
9GV0312G301	9GV0312G302	9GV0312G301	9GV0312G3D01	9GV0312P3G03	38×38×28mm	Yes	✓	✓	✓	15
9GV0312G3011	9GV0312G3021	9GV0312G3011	—	—	38×38×28mm	No	✓	✓	✓	15
9GV0312H301	9GV0312H302	9GV0312H301	—	—	38×38×28mm	Yes	✓	✓	✓	15
9GV0312H3011	—	9GV0312H3011	—	—	38×38×28mm	No	✓	✓	✓	15
9GV0312J301	9GV0312J302	9GV0312J301	9GV0312J3D01	9GV0312P3J03	38×38×28mm	Yes	✓	✓	✓	15
9GV0312J3011	9GV0312J3021	9GV0312J3011	—	9GV0312P3J031	38×38×28mm	No	✓	✓	✓	15
9GV0312K301	—	9GV0312K301	9GV0312K3D01	9GV0312P3K01	38×38×28mm	Yes	✓	✓	✓	15
9GV0312K3011	—	9GV0312K3011	—	—	38×38×28mm	No	✓	✓	✓	15
9GV0412C301	—	9GV0412C301	9GV0412C3D01	—	40×40×28mm	Yes	✓	✓	✓	41
9GV0412C3011	—	9GV0412C3011	9GV0412C3D011	—	40×40×28mm	No	✓	✓	✓	41
9GV0412G301	9GV0412G302	9GV0412G301	9GV0412G3D01	9GV0412P3G03	40×40×28mm	Yes	✓	✓	✓	41
9GV0412G3011	9GV0412G3021	9GV0412G3011	9GV0412G3D011	9GV0412P3G031	40×40×28mm	No	✓	✓	✓	41
9GV0412H301	—	9GV0412H301	9GV0412H3D01	9GV0412P3H01	40×40×28mm	Yes	✓	✓	✓	41
9GV0412H3011	—	9GV0412H3011	—	—	40×40×28mm	No	✓	✓	✓	41
9GV0412J301	9GV0412J302	9GV0412J301	9GV0412J3D01	9GV0412P3J03	40×40×28mm	Yes	✓	✓	✓	41
9GV0412J3011	9GV0412J3021	9GV0412J3011	9GV0412J3D011	9GV0412P3J031	40×40×28mm	No	✓	✓	✓	41
9GV0412K301	9GV0412K302	9GV0412K301	9GV0412K3D01	9GV0412P3K03	40×40×28mm	Yes	✓	✓	✓	41
9GV0412K3011	—	9GV0412K3011	—	—	40×40×28mm	No	✓	✓	✓	41
9GV0612P1G03	9GV0612G102	9GV0612G101	9GV0612G1D01	9GV0612P1G03	60×60×38mm	Yes	✓	✓	✓	83
9GV0612P1G031	9GV0612G1021	9GV0612G1011	9GV0612G1D011	9GV0612P1G031	60×60×38mm	No	✓	✓	✓	83
9GV0612P1H03	9GV0612H102	9GV0612H101	9GV0612H1D01	9GV0612P1H03	60×60×38mm	Yes	✓	✓	✓	83
9GV0612P1H031	9GV0612H1021	9GV0612H1011	9GV0612H1D011	9GV0612P1H031	60×60×38mm	No	✓	✓	✓	83
9GV0612P1L01	9GV0612L102	—	—	9GV0612P1L01	60×60×38mm	Yes	✓	✓	✓	83
9GV0612P1L011	9GV0612L1021	9GV0612L1011	9GV0612L1D011	9GV0612P1L011	60×60×38mm	No	✓	✓	✓	83
9GV0612P1M03	—	9GV0612M101	9GV0612M1D01	9GV0612P1M03	60×60×38mm	Yes	✓	✓	✓	83
9GV0612P1M031	—	9GV0612M1011	9GV0612M1D011	9GV0612P1M031	60×60×38mm	No	✓	✓	✓	83
9GV0624P1G03	9GV0624G102	—	9GV0624G1D01	9GV0624P1G03	60×60×38mm	Yes	✓	✓	✓	83
9GV0624P1G031	9GV0624G1021	—	—	9GV0624P1G031	60×60×38mm	No	✓	✓	✓	83
9GV0624P1M03	9GV0624M102	9GV0624M101	—	9GV0624P1M03	60×60×38mm	Yes	✓	✓	✓	83
9GV0624P1M031	—	—	—	9GV0624P1M031	60×60×38mm	No	✓	✓	✓	83
9GV0648P1H03	—	—	—	9GV0648P1H03	60×60×38mm	Yes	✓	✓	✓	83
9GV0648P1H031	—	—	—	9GV0648P1H031	60×60×38mm	No	✓	✓	✓	83
9GV0812P1F03	—	—	—	9GV0812P1F03	80×80×38mm	Yes	✓	✓	✓	131
9GV0812P1F031	—	—	—	9GV0812P1F031	80×80×38mm	No	✓	✓	✓	131
9GV0812P1G03	9GV0812G102	9GV0812G101	—	9GV0812P1G03	80×80×38mm	Yes	✓	✓	✓	131
9GV0812P1G031	9GV0812G1021	9GV0812G1011	—	9GV0812P1G031	80×80×38mm	No	✓	✓	✓	131
9GV0812P1H03	9GV0812H102	9GV0812H101	—	9GV0812P1H03	80×80×38mm	Yes	✓	✓	✓	131
9GV0812P1H031	9GV0812H1021	9GV0812H1011	—	9GV0812P1H031	80×80×38mm	No	✓	✓	✓	131
9GV0812P1M03	—	—	—	9GV0812P1M03	80×80×38mm	Yes	✓	✓	✓	131
9GV0812P1M031	—	—	—	9GV0812P1M031	80×80×38mm	No	✓	✓	✓	131
9GV0812P4J03	9GV0812J402	9GV0812J401	—	9GV0812P4J03	80×80×25mm	Yes	✓	✓	✓	107
9GV0812P4J031	9GV0812J4021	9GV0812J4011	—	9GV0812P4J031	80×80×25mm	No	✓	✓	✓	107
9GV0812P4K03	—	9GV0812K401	9GV0812K4D01	9GV0812P4K03	80×80×25mm	Yes	✓	✓	✓	107
9GV0812P4K031	9GV0812K4021	9GV0812K4011	9GV0812K4D011	9GV0812P4K031	80×80×25mm	No	✓	✓	✓	107
9GV0824P1G03	9GV0824G102	9GV0824G101	—	9GV0824P1G03	80×80×38mm	Yes	✓	✓	✓	131
9GV0824P1G031	—	—	—	9GV0824P1G031	80×80×38mm	No	✓	✓	✓	131
9GV0824P4K01	9GV0824K402	9GV0824K401	—	9GV0824P4K01	80×80×25mm	Yes	✓	✓	✓	107
9GV0824P4K011	—	—	—	9GV0824P4K011	80×80×25mm	No	✓	✓	✓	107
9GV0848P1G03	9GV0848G102	9GV0848G101	—	9GV0848P1G03	80×80×38mm	Yes	✓	✓	✓	131
9GV0848P1G031	—	9GV0848G1011	—	9GV0848P1G031	80×80×38mm	No	✓	✓	✓	131
9GV0848P4K03	—	9GV0848K401	—	9GV0848P4K03	80×80×25mm	Yes	✓	✓	✓	107
9GV0848P4K031	—	—	—	9GV0848P4K031	80×80×25mm	No	✓	✓	✓	107
9GV0912P1F03	—	—	—	9GV0912P1F03	92×92×38mm	Yes	✓	✓	✓	151

Models listed in the main section of this catalog	List of models (models not listed in the main section of this catalog are options. Standards for optional model numbers may differ from the certified standards listed at right. Contact us for details of models with "-" model numbers.)				Frame Size	Rib	Standard (certification status is for the models listed in this catalog, and standards for optional model numbers may differ.)			page
	Without sensor	With pulse sensor	With lock sensor	With PWM control function and pulse sensor			UL (cUL)	CSA (cUL)	TÜV	
							✓	✓	✓	
9GV0912P1F031	—	—	—	9GV0912P1F031	92×92×38mm	No	✓	✓	✓	151
9GV0912P1G03	—	—	—	9GV0912P1G03	92×92×38mm	Yes	✓	✓	✓	151
9GV0912P1G031	—	—	—	9GV0912P1G031	92×92×38mm	No	✓	✓	✓	151
9GV0912P1H03	9GV0912H102	—	9GV0912H1D01	9GV0912P1H03	92×92×38mm	Yes	✓	✓	✓	151
9GV0912P1H031	—	—	—	9GV0912P1H031	92×92×38mm	No	✓	✓	✓	151
9GV0948P1F03	—	—	—	9GV0948P1F03	92×92×38mm	Yes	✓	✓	✓	151
9GV0948P1F031	—	—	—	9GV0948P1F031	92×92×38mm	No	✓	✓	✓	151
9GV0948P1H03	9GV0948H102	9GV0948H101	—	9GV0948P1H03	92×92×38mm	Yes	✓	✓	✓	151
9GV0948P1H031	9GV0948H1021	—	—	9GV0948P1H031	92×92×38mm	No	✓	✓	✓	151
9GV1212P1G01	—	—	—	9GV1212P1G01	120×120×38mm	Yes	✓	✓	✓	169
9GV1212P1G011	—	9GV1212G1011	—	9GV1212P1G011	120×120×38mm	No	✓	✓	✓	169
9GV1212P1J01	9GV1212J102	9GV1212J101	—	9GV1212P1J01	120×120×38mm	Yes	✓	✓	✓	169
9GV1212P1J011	9GV1212J1021	9GV1212J1011	—	9GV1212P1J011	120×120×38mm	No	✓	✓	✓	169
9GV1212P4G01	9GV1212G402	9GV1212G401	—	9GV1212P4G01	120×120×25mm	Yes	✓	✓	✓	159
9GV1212P4G011	9GV1212G4021	9GV1212G4011	—	9GV1212P4G011	120×120×25mm	No	✓	✓	✓	159
9GV1224P1H01	9GV1224H102	9GV1224H101	9GV1224H1D01	9GV1224P1H01	120×120×38mm	Yes	✓	✓	✓	169
9GV1224P1H011	9GV1224H1021	9GV1224H1011	9GV1224H1D011	9GV1224P1H011	120×120×38mm	No	✓	✓	✓	169
9GV1224P1J01	9GV1224J102	9GV1224J101	9GV1224J1D01	9GV1224P1J01	120×120×38mm	Yes	✓	✓	✓	169
9GV1224P1J011	9GV1224J1021	9GV1224J1011	9GV1224J1D011	9GV1224P1J011	120×120×38mm	No	✓	✓	✓	169
9GV1224P4G01	9GV1224G402	9GV1224G401	9GV1224G4D01	9GV1224P4G01	120×120×25mm	Yes	✓	✓	✓	159
9GV1224P4G011	9GV1224G4021	—	—	9GV1224P4G011	120×120×25mm	No	✓	✓	✓	159
9GV1248P1J01	9GV1248J102	9GV1248J101	9GV1248J1D01	9GV1248P1J01	120×120×38mm	Yes	✓	✓	✓	169
9GV1248P1J011	9GV1248J1021	9GV1248J1011	—	9GV1248P1J011	120×120×38mm	No	✓	✓	✓	169
9GV1248P4G01	9GV1248G402	9GV1248G401	—	9GV1248P4G01	120×120×25mm	Yes	✓	✓	✓	159
9GV1248P4G011	—	9GV1248G4011	—	9GV1248P4G011	120×120×25mm	No	✓	✓	✓	159
9GV1248P4H01	9GV1248H402	9GV1248H401	—	9GV1248P4H01	120×120×25mm	Yes	✓	✓	✓	159
9GV1248P4H011	—	—	—	9GV1248P4H011	120×120×25mm	No	✓	✓	✓	159
9GV1248P4J01	—	—	—	9GV1248P4J01	120×120×25mm	Yes	✓	✓	✓	159
9GV1248P4J011	—	—	—	9GV1248P4J011	120×120×25mm	No	✓	✓	✓	159
9GV1412P1G001	—	—	—	9GV1412P1G001	140×140×38mm	No	✓	✓	✓	183
9GV1412P1H001	—	—	—	9GV1412P1H001	140×140×38mm	No	✓	✓	✓	183
9GV1412P1S001	—	—	—	9GV1412P1S001	140×140×38mm	No	✓	✓	✓	183
9GV1424P1G001	—	—	—	9GV1424P1G001	140×140×38mm	No	✓	✓	✓	183
9GV1424P1H001	—	—	—	9GV1424P1H001	140×140×38mm	No	✓	✓	✓	183
9GV1424P1S001	—	—	—	9GV1424P1S001	140×140×38mm	No	✓	✓	✓	183
9GV1448P1G001	—	—	—	9GV1448P1G001	140×140×38mm	No	✓	✓	✓	183
9GV1448P1H001	—	—	—	9GV1448P1H001	140×140×38mm	No	✓	✓	✓	183
9GV1448P1S001	—	—	—	9GV1448P1S001	140×140×38mm	No	✓	✓	✓	183
9GV1512H501	9GV1512H502	9GV1512H501	—	9GV1512P5H03	150×150×50mm	Yes	✓	✓	✓	189
9GV1512H5011	9GV1512H5021	9GV1512H5011	—	—	150×150×50mm	No	✓	✓	✓	189
9GV1512M501	9GV1512M502	9GV1512M501	—	9GV1512P5M03	150×150×50mm	Yes	✓	✓	✓	189
9GV1512M5011	9GV1512M5021	9GV1512M5011	—	—	150×150×50mm	No	✓	✓	✓	189
9GV1524M501	9GV1524M502	9GV1524M501	9GV1524M5D01	—	150×150×50mm	Yes	✓	✓	✓	189
9GV1524M5011	—	9GV1524M5011	—	—	150×150×50mm	No	✓	✓	✓	189
9GV2048P0G201	9GV2048G0202	—	—	9GV2048P0G201	φ200mm×70mm	No	✓	✓	✓	203
9GV3612G301	9GV3612G302	9GV3612G301	9GV3612G3D01	9GV3612P3G03	36×36×28mm	Yes	✓	✓	✓	11
9GV3612J301	9GV3612J302	9GV3612J301	9GV3612J3D01	9GV3612P3J03	36×36×28mm	Yes	✓	✓	✓	11
9GV5724H501	9GV5724H502	9GV5724H501	—	9GV5724P5H03	φ172mm×150mm×51mm	No	✓	✓	✓	197
9GV5748H501	9GV5748H502	9GV5748H501	—	9GV5748P5H01	φ172mm×150mm×51mm	No	✓	✓	✓	197
9GX3612P3K001	—	—	—	9GX3612P3K001	36×36×28mm	Yes	✓	✓	✓	11
9HV0412P3K001	—	—	—	9HV0412P3K001	40×40×28mm	No	✓	✓	✓	31
9HV0612P1J001	—	—	—	9HV0612P1J001	60×60×38mm	Yes	✓	✓	✓	77
9HV0612P1J0011	—	—	—	9HV0612P1J0011	60×60×38mm	No	✓	✓	✓	77
9HV0812P1G001	9HV0812G1002	9HV0812G1001	—	9HV0812P1G001	80×80×38mm	Yes	✓	✓	✓	125
9HV0812P1G0011	9HV0812G10021	9HV0812G10011	—	9HV0812P1G0011	80×80×38mm	No	✓	✓	✓	125
9HV0824P1G003	—	—	9HV0824G1D001	9HV0824P1G003	80×80×38mm	Yes	✓	✓	✓	125
9HV0824P1G0011	—	—	—	9HV0824P1G0011	80×80×38mm	No	✓	✓	✓	125
9HV0848P1G001	9HV0848G1002	9HV0848G1001	9HV0848G1D001	9HV0848P1G001	80×80×38mm	Yes	✓	✓	✓	125
9HV0848P1G0011	9HV0848G10021	9HV0848G10011	—	9HV0848P1G0011	80×80×38mm	No	✓	✓	✓	125
9HV0912P1G001	—	—	—	9HV0912P1G001	92×92×38mm	Yes	✓	✓	✓	149
9HV0912P1G0011	—	—	—	9HV0912P1G0011	92×92×38mm	No	✓	✓	✓	149
9HV0948P1G001	—	—	—	9HV0948P1G001	92×92×38mm	Yes	✓	✓	✓	149

Please contact your point of sale regarding low-speed sensors.

Models listed in the main section of this catalog	List of models (models not listed in the main section of this catalog are options. Standards for optional model numbers may differ from the certified standards listed at right. Contact us for details of models with "-" model numbers.)				Frame Size	Rib	Standard (certification status is for the models listed in this catalog, and standards for optional model numbers may differ.)			page
	Without sensor	With pulse sensor	With lock sensor	With PWM control function and pulse sensor			UL (cUL)	CSA (cUL)	TÜV	
9HV0948P1G0011	—	—	—	9HV0948P1G0011	92×92×38mm	No	✓	✓	✓	149
9HV1224P1A001	—	—	—	9HV1224P1A001	120×120×38mm	No	✓	✓	✓	167
9HV1248P1G001	9HV1248G1002	9HV1248G1001	—	9HV1248P1G001	120×120×38mm	No	✓	✓	✓	167
9HV1248P1H001	9HV1248H1002	9HV1248H1001	—	9HV1248P1H001	120×120×38mm	No	✓	✓	✓	167
9HV5724P5H001	—	—	9HV5724H5D001	9HV5724P5H001	φ172mm×150mm×51mm	No	✓	✓	✓	193
9HV5748P5G001	—	—	—	9HV5748P5G001	φ172mm×150mm×51mm	No	✓	✓	✓	193
9HVA0812P1G001	—	—	—	9HVA0812P1G001	80×80×38mm	Yes	✓	✓	✓	123
9HVA0812P1G0011	—	—	—	9HVA0812P1G0011	80×80×38mm	No	✓	✓	✓	123
9L0412H301	9L0412H302	9L0412H301	9L0412H3D01	—	40×40×28mm	No	✓	✓	✓	319
9L0412J301	9L0412J302	9L0412J301	9L0412J3D01	9L0412P3J01	40×40×28mm	No	✓	✓	✓	319
9L0412M301	9L0412M302	9L0412M301	9L0412M3D01	—	40×40×28mm	No	✓	✓	✓	319
9LB1412H501	9LB1412H502	9LB1412H501	9LB1412H5D01	—	140×140×51mm	No	✓	✓	✓	351
9LB1412M501	9LB1412M502	9LB1412M501	9LB1412M5D01	—	140×140×51mm	No	✓	✓	✓	351
9LB1412S501	9LB1412S502	9LB1412S501	9LB1412S5D01	—	140×140×51mm	No	✓	✓	✓	351
9LB1424B501	9LB1424B502	9LB1424B501	—	—	140×140×51mm	No	—	—	—	351
9LB1424H501	9LB1424H502	9LB1424H501	9LB1424H5D01	—	140×140×51mm	No	✓	✓	✓	351
9LB1424M501	9LB1424M502	9LB1424M501	9LB1424M5D01	—	140×140×51mm	No	✓	✓	✓	351
9LB1424S501	9LB1424S502	9LB1424S501	9LB1424S5D01	—	140×140×51mm	No	✓	✓	✓	351
9LB1448F501	—	9LB1448F501	—	—	140×140×51mm	No	—	—	—	351
9LB1448H501	9LB1448H502	9LB1448H501	9LB1448H5D01	—	140×140×51mm	No	✓	✓	✓	351
9LB1448M501	9LB1448M502	9LB1448M501	9LB1448M5D01	—	140×140×51mm	No	✓	✓	✓	351
9LB1448S501	9LB1448S502	9LB1448S501	9LB1448S5D01	—	140×140×51mm	No	✓	✓	✓	351
9LG0612P4H001	—	9LG0612H4001	9LG0612H4D001	9LG0612P4H001	60×60×25mm	No	✓	✓	✓	321
9LG0612P4J001	—	—	9LG0612J4D001	9LG0612P4J001	60×60×25mm	No	✓	✓	✓	321
9LG0612P4M001	—	9LG0624M4001	9LG0612M4D001	9LG0612P4M001	60×60×25mm	No	✓	✓	✓	321
9LG0612P4S001	—	9LG0612S4001	—	9LG0612P4S001	60×60×25mm	No	✓	✓	✓	321
9LG0624P4H001	—	—	—	9LG0624P4H001	60×60×25mm	No	✓	✓	✓	321
9LG0624P4J001	—	—	—	9LG0624P4J001	60×60×25mm	No	✓	✓	✓	321
9LG0624P4M001	—	9LG0624M4001	—	9LG0624P4M001	60×60×25mm	No	✓	✓	✓	321
9LG0624P4S001	—	—	—	9LG0624P4S001	60×60×25mm	No	✓	✓	✓	321
9LG0648P4H001	—	—	—	9LG0648P4H001	60×60×25mm	No	✓	✓	✓	321
9LG0648P4J001	—	—	—	9LG0648P4J001	60×60×25mm	No	✓	✓	✓	321
9LG0648P4M001	—	—	—	9LG0648P4M001	60×60×25mm	No	✓	✓	✓	321
9LG0648P4S001	—	—	—	9LG0648P4S001	60×60×25mm	No	✓	✓	✓	321
9LG0812P4G001	—	—	—	9LG0812P4G001	80×80×25mm	No	✓	✓	✓	329
9LG0812P4H001	—	—	—	9LG0812P4H001	80×80×25mm	No	✓	✓	✓	329
9LG0812P4J001	—	—	9LG0812J4D001	9LG0812P4J001	80×80×25mm	No	✓	✓	✓	329
9LG0824P4G001	9LG0824G4002	—	9LG0824G4D001	9LG0824P4G001	80×80×25mm	No	✓	✓	✓	329
9LG0824P4H001	—	—	—	9LG0824P4H001	80×80×25mm	No	✓	✓	✓	329
9LG0824P4J001	—	—	9LG0824J4D001	9LG0824P4J001	80×80×25mm	No	✓	✓	✓	329
9LG0912P1F001	—	—	—	9LG0912P1F001	92×92×38mm	No	✓	✓	✓	339
9LG0912P1H001	—	—	—	9LG0912P1H001	92×92×38mm	No	✓	✓	✓	339
9LG0912P4G001	9LG0912G4002	—	—	9LG0912P4G001	92×92×25mm	No	✓	✓	✓	335
9LG0912P4H001	—	—	—	9LG0912P4H001	92×92×25mm	No	✓	✓	✓	335
9LG0912P4J001	—	—	—	9LG0912P4J001	92×92×25mm	No	✓	✓	✓	335
9LG0912P4S001	—	—	—	9LG0912P4S001	92×92×25mm	No	✓	✓	✓	335
9LG0924P1F001	—	—	—	9LG0924P1F001	92×92×38mm	No	✓	✓	✓	339
9LG0924P1H001	—	—	—	9LG0924P1H001	92×92×38mm	No	✓	✓	✓	339
9LG0924P4G001	—	—	—	9LG0924P4G001	92×92×25mm	No	✓	✓	✓	335
9LG0924P4H001	—	—	—	9LG0924P4H001	92×92×25mm	No	✓	✓	✓	335
9LG0924P4J001	—	—	9LG0924J4D001	9LG0924P4J001	92×92×25mm	No	✓	✓	✓	335
9LG0924P4S001	—	—	9LG0924S4D001	9LG0924P4S001	92×92×25mm	No	✓	✓	✓	335
9LG1212P1G001	—	—	—	9LG1212P1G001	120×120×38mm	No	✓	✓	✓	341
9LG1212P1H001	—	—	—	9LG1212P1H001	120×120×38mm	No	✓	✓	✓	341
9LG1212P1S001	—	—	—	9LG1212P1S001	120×120×38mm	No	✓	✓	✓	341
9LG1224P1G001	—	—	9LG1224G1D001	9LG1224P1G001	120×120×38mm	No	✓	✓	✓	341
9LG1224P1H001	—	—	9LG1224H1D001	9LG1224P1H001	120×120×38mm	No	✓	✓	✓	341
9LG1224P1S001	—	9LG1224S1001	9LG1224S1D001	9LG1224P1S001	120×120×38mm	No	✓	✓	✓	341
9LG1248P1G001	9LG1248G1002	—	—	9LG1248P1G001	120×120×38mm	No	✓	✓	✓	341
9LG1248P1H001	—	—	—	9LG1248P1H001	120×120×38mm	No	✓	✓	✓	341
9LG1248P1S001	—	—	—	9LG1248P1S001	120×120×38mm	No	✓	✓	✓	341
9RF1312P3H001	—	—	—	9RF1312P3H001	φ136mm×28mm	No	✓	✓	✓	243

Models listed in the main section of this catalog	List of models (models not listed in the main section of this catalog are options. Standards for optional model numbers may differ from the certified standards listed at right. Contact us for details of models with "-" model numbers.)				Frame Size	Rib	Standard (certification status is for the models listed in this catalog, and standards for optional model numbers may differ.)			page
	Without sensor	With pulse sensor	With lock sensor	With PWM control function and pulse sensor			UL	CSA	TÜV	
							(cUL)	(cUL)		
9RF1324P3H001	—	—	—	9RF1324P3H001	∅ 136mm × 28mm	No	✓	✓	✓	243
9S0612F401	9S0612F402	9S0612F401	9S0612F4D01	9S0612P4F01	60 × 60 × 25mm	Yes	✓	✓	✓	67
9S0612F4011	9S0612F4021	9S0612F4011	9S0612F4D011	9S0612P4F011	60 × 60 × 25mm	No	✓	✓	✓	67
9S0612H401	9S0612H402	9S0612H401	9S0612H4D01	9S0612P4H01	60 × 60 × 25mm	Yes	✓	✓	✓	67
9S0612H4011	9S0612H4021	9S0612H4011	9S0612H4D011	9S0612P4H011	60 × 60 × 25mm	No	✓	✓	✓	67
9S0612M401	9S0612M402	9S0612M401	9S0612M4D01	9S0612P4M01	60 × 60 × 25mm	Yes	✓	✓	✓	67
9S0612M4011	9S0612M4021	9S0612M4011	9S0612M4D011	—	60 × 60 × 25mm	No	✓	✓	✓	67
9S0612S401	9S0612S402	9S0612S401	9S0612S4D01	9S0612P4S01	60 × 60 × 25mm	Yes	✓	✓	✓	67
9S0612S4011	—	9S0612S4011	—	—	60 × 60 × 25mm	No	✓	✓	✓	67
9S0812F401	9S0812F402	9S0812F401	9S0812F4D01	9S0812P4F01	80 × 80 × 25mm	Yes	✓	✓	✓	105
9S0812F4011	9S0812F4021	9S0812F4011	9S0812F4D011	9S0812P4F011	80 × 80 × 25mm	No	✓	✓	✓	105
9S0812H401	9S0812H402	9S0812H401	9S0812H4D01	—	80 × 80 × 25mm	Yes	✓	✓	—	105
9S0812H4011	—	9S0812H4011	9S0812H4D011	—	80 × 80 × 25mm	No	✓	✓	—	105
9S0812L401	9S0812L402	9S0812L401	9S0812L4D01	—	80 × 80 × 25mm	Yes	✓	✓	✓	105
9S0812L4011	9S0812L4021	9S0812L4011	9S0812L4D011	—	80 × 80 × 25mm	No	✓	✓	✓	105
9S0812M401	9S0812M402	9S0812M401	9S0812M4D01	9S0812P4M01	80 × 80 × 25mm	Yes	✓	✓	✓	105
9S0812M4011	9S0812M4021	9S0812M4011	9S0812M4D011	9S0812P4M011	80 × 80 × 25mm	No	✓	✓	✓	105
9S0824L401	9S0824L402	9S0824L401	9S0824L4D01	—	80 × 80 × 25mm	Yes	✓	✓	✓	105
9S0824L4011	9S0824L4021	9S0824L4011	9S0824L4D011	—	80 × 80 × 25mm	No	✓	✓	✓	105
9S0824M401	9S0824M402	9S0824M401	9S0824M4D01	—	80 × 80 × 25mm	Yes	✓	✓	✓	105
9S0824M4011	9S0824M4021	9S0824M4011	9S0824M4D011	—	80 × 80 × 25mm	No	✓	✓	✓	105
9S0912F401	9S0912F402	9S0912F401	9S0912F4D01	9S0912P4F01	92 × 92 × 25mm	Yes	✓	✓	✓	141
9S0912F4011	9S0912F4021	9S0912F4011	9S0912F4D011	9S0912P4F011	92 × 92 × 25mm	No	✓	✓	✓	141
9S0912L401	9S0912L402	9S0912L401	9S0912L4D01	—	92 × 92 × 25mm	Yes	✓	✓	✓	141
9S0912L4011	9S0912L4021	9S0912L4011	9S0912L4D011	—	92 × 92 × 25mm	No	✓	✓	✓	141
9S0912M401	9S0912M402	9S0912M401	9S0912M4D01	9S0912P4M01	92 × 92 × 25mm	Yes	✓	✓	✓	141
9S0912M4011	9S0912M4021	9S0912M4011	9S0912M4D011	9S0912P4M011	92 × 92 × 25mm	No	✓	✓	✓	141
9S0924F401	9S0924F402	9S0924F401	9S0924F4D01	—	92 × 92 × 25mm	Yes	✓	✓	✓	141
9S0924F4011	9S0924F4021	9S0924F4011	—	—	92 × 92 × 25mm	No	✓	✓	✓	141
9S0924L401	9S0924L402	9S0924L401	9S0924L4D01	—	92 × 92 × 25mm	Yes	✓	✓	✓	141
9S0924L4011	9S0924L4021	9S0924L4011	—	—	92 × 92 × 25mm	No	✓	✓	✓	141
9S0924M401	9S0924M402	9S0924M401	9S0924M4D01	—	92 × 92 × 25mm	Yes	✓	✓	✓	141
9S0924M4011	9S0924M4021	9S0924M4011	—	—	92 × 92 × 25mm	No	✓	✓	✓	141
9S1212F401	9S1212F402	9S1212F401	9S1212F4D01	9S1212P4F01	120 × 120 × 25mm	Yes	✓	✓	✓	157
9S1212F4011	9S1212F4021	9S1212F4011	9S1212F4D011	9S1212P4F011	120 × 120 × 25mm	No	✓	✓	✓	157
9S1212H401	9S1212H402	9S1212H401	9S1212H4D01	9S1212P4H01	120 × 120 × 25mm	Yes	✓	✓	✓	157
9S1212H4011	9S1212H4021	9S1212H4011	—	9S1212P4H011	120 × 120 × 25mm	No	✓	✓	✓	157
9S1212L401	9S1212L402	9S1212L401	9S1212L4D01	—	120 × 120 × 25mm	Yes	✓	✓	✓	157
9S1212L4011	9S1212L4021	9S1212L4011	9S1212L4D011	9S1212P4L011	120 × 120 × 25mm	No	✓	✓	✓	157
9S1212M401	9S1212M402	9S1212M401	9S1212M4D01	9S1212P4M01	120 × 120 × 25mm	Yes	✓	✓	✓	157
9S1212M4011	9S1212M4021	9S1212M4011	9S1212M4D011	9S1212P4M011	120 × 120 × 25mm	No	✓	✓	✓	157
9S1224M401	9S1224M402	9S1224M401	9S1224M4D01	—	120 × 120 × 25mm	Yes	✓	✓	✓	157
9S1224M4011	9S1224M4021	9S1224M4011	9S1224M4D011	—	120 × 120 × 25mm	No	✓	✓	✓	157
9SG1212G101	9SG1212G102	9SG1212G101	9SG1212G1D01	9SG1212P1G01	120 × 120 × 38mm	No	✓	✓	✓	177
9SG1224G101	9SG1224G102	9SG1224G101	9SG1224G1D01	9SG1224P1G01	120 × 120 × 38mm	No	✓	✓	✓	177
9SG1224H101	9SG1224H102	9SG1224H101	9SG1224H1D01	—	120 × 120 × 38mm	No	—	—	—	177
9SG1248G101	9SG1248G102	9SG1248G101	—	9SG1248P1G01	120 × 120 × 38mm	No	✓	✓	✓	177
9SG5724P5H61	9SG5724H562	—	—	9SG5724P5H61	∅ 172mm × 150mm × 51mm	No	✓	✓	✓	195
9SG5748P5G01	—	—	—	9SG5748P5G01	∅ 172mm × 150mm × 51mm	No	✓	✓	✓	195
9SG5748P5H01	—	—	—	9SG5748P5H01	∅ 172mm × 150mm × 51mm	No	✓	✓	✓	195
9TG24P0G01	9TG24G002	9TG24G001	—	9TG24P0G01	∅ 175mm × 69mm	—	✓	✓	✓	381
9TG24P0S01	9TG24S002	9TG24S001	—	9TG24P0S01	∅ 175mm × 69mm	—	✓	✓	✓	381
9TGA24P0H001	—	—	—	9TGA24P0H001	∅ 175mm × 69mm	—	✓	✓	✓	379
9TGA48P0G001	—	—	—	9TGA48P0G001	∅ 175mm × 69mm	—	✓	✓	✓	379
9TG48P0G01	—	—	—	9TG48P0G01	∅ 175mm × 69mm	—	✓	✓	✓	381
9TJ24P0H61	—	—	—	9TJ24P0H61	∅ 133mm × 91mm	—	✓	✓	✓	375
9TJ48P0H01	—	—	—	9TJ48P0H01	∅ 133mm × 91mm	—	✓	✓	✓	375
9TM24P4H01	—	—	—	9TM24P4H01	∅ 100mm × 25mm	—	✓	✓	✓	373
9TM48P4H01	—	—	—	9TM48P4H01	∅ 100mm × 25mm	—	✓	✓	✓	373
9TN24P1H01	—	—	—	9TN24P1H01	∅ 150mm × 35mm	—	✓	✓	✓	377
9TN48P1H01	—	—	—	9TN48P1H01	∅ 150mm × 35mm	—	✓	✓	✓	377
9TP24P0H001	—	—	—	9TP24P0H001	∅ 221mm × 71mm	—	✓	✓	✓	383

Models listed in the main section of this catalog	List of models (models not listed in the main section of this catalog are options. Standards for optional model numbers may differ from the certified standards listed at right. Contact us for details of models with "-" model numbers.)				Frame Size	Rib	Standard (certification status is for the models listed in this catalog, and standards for optional model numbers may differ.)			page
	Without sensor	With pulse sensor	With lock sensor	With PWM control function and pulse sensor			UL (cUL)	CSA (cUL)	TÜV	
	9TP48P0G001	—	—	—			9TP48P0G001	φ 221mm×71mm	—	
9TP48P0H001	—	—	—	9TP48P0H001	φ 221mm×71mm	—	✓	✓	✓	383
9TS48P0G001	—	—	—	9TS48P0G001	φ 225mm×99mm	—	✓	✓	✓	385
9TS48P0H001	—	—	—	9TS48P0H001	φ 225mm×99mm	—	✓	✓	✓	385
9W1TG48P0H61	—	—	—	9W1TG48P0H61	φ 175mm×69mm	—	✓	✓	✓	301
9W1TJ24P0H61	—	—	—	9W1TJ24P0H61	φ 133mm×91mm	—	✓	✓	✓	297
9W1TJ48P0H61	—	—	—	9W1TJ48P0H61	φ 133mm×91mm	—	✓	✓	✓	297
9W1TM48P4G01	—	—	—	9W1TM48P4G01	φ 100mm×25mm	—	✓	✓	✓	295
9W1TM48P4H01	—	—	—	9W1TM48P4H01	φ 100mm×25mm	—	✓	✓	✓	295
9W1TN48P1H01	—	—	—	9W1TN48P1H01	φ 150mm×35mm	—	✓	✓	✓	299
9WB1412H501	9WB1412H502	9WB1412H501	—	—	140×140×51mm	No	✓	✓	✓	287
9WB1412M501	9WB1412M502	9WB1412M501	9WB1412M5D01	—	140×140×51mm	No	✓	✓	✓	287
9WB1412S501	9WB1412S502	9WB1412S501	9WB1412S5D01	—	140×140×51mm	No	✓	✓	✓	287
9WB1424H501	9WB1424H502	9WB1424H501	9WB1424H5D01	—	140×140×51mm	No	✓	✓	✓	287
9WB1424M501	9WB1424M502	9WB1424M501	—	—	140×140×51mm	No	✓	✓	✓	287
9WB1448H501	9WB1448H502	9WB1448H501	9WB1448H5D01	—	140×140×51mm	No	✓	✓	✓	287
9WB1448S501	9WB1448S502	9WB1448S501	9WB1448S5D01	—	140×140×51mm	No	✓	✓	✓	287
9WE1724K501	9WE1724K502	9WE1724K501	—	—	φ 172mm×51mm	No	✓	✓	✓	292
9WE5724K501	9WE5724K502	9WE5724K501	—	—	φ 172mm×150mm×51mm	No	✓	✓	✓	291
9WE5748K501	9WE5748K502	9WE5748K501	9WE5748K5D01	9WE5748P5K01	φ 172mm×150mm×51mm	No	✓	✓	✓	291
9WF0424F601	9WF0424F602	9WF0424F601	9WF0424F6D01	—	40×40×20mm	Yes	✓	✓	✓	306
9WF0424H601	9WF0424H602	9WF0424H601	9WF0424H6D01	—	40×40×20mm	Yes	✓	✓	✓	306
9WF0424H701	9WF0424H702	9WF0424H701	9WF0424H7D01	—	40×40×15mm	Yes	✓	✓	✓	305
9WF0624H401	9WF0624H402	9WF0624H401	9WF0624H4D01	—	60×60×25mm	Yes	✓	✓	✓	309
9WF0624H601	—	9WF0624H601	9WF0624H6D01	—	60×60×20mm	Yes	✓	✓	✓	308
9WF0624H701	9WF0624H702	9WF0624H701	9WF0624H7D01	—	60×60×15mm	Yes	✓	✓	✓	307
9WF0824S401	9WF0824S402	9WF0824S401	9WF0824S4D01	—	80×80×25mm	Yes	✓	✓	✓	310
9WF0924H201	9WF0924H202	9WF0924H201	9WF0924H2D01	—	92×92×32mm	Yes	✓	✓	✓	313
9WF0924H2011	—	—	—	—	92×92×32mm	No	✓	✓	✓	313
9WF0924H401	9WF0924H402	9WF0924H401	9WF0924H4D01	—	92×92×25mm	Yes	✓	✓	✓	311
9WF0924H4011	—	—	9WF0924H4D011	—	92×92×25mm	No	✓	✓	✓	311
9WF0924S201	9WF0924S202	9WF0924S201	9WF0924S2D01	—	92×92×32mm	Yes	✓	✓	✓	313
9WF0924S2011	—	—	—	—	92×92×32mm	No	✓	✓	✓	313
9WF1224H101	9WF1224H102	9WF1224H101	9WF1224H1D01	—	120×120×38mm	Yes	✓	✓	✓	315
9WG1212E101-E	9WG1212E102-E	9WG1212E101-E	9WG1212E1D01-E	—	120×120×38mm	No	✓	✓	✓	281
9WG1212F101-E	9WG1212F102-E	9WG1212F101-E	—	—	120×120×38mm	No	✓	✓	✓	281
9WG1212G101-E	9WG1212G102-E	9WG1212G101-E	9WG1212G1D01-E	—	120×120×38mm	No	✓	✓	✓	281
9WG1212H101-E	9WG1212H102-E	9WG1212H101-E	9WG1212H1D01-E	—	120×120×38mm	No	✓	✓	✓	281
9WG1212M101-E	9WG1212M102-E	9WG1212M101-E	—	—	120×120×38mm	No	✓	✓	✓	281
9WG1224E101-E	9WG1224E102-E	9WG1224E101-E	9WG1224E1D01-E	—	120×120×38mm	No	✓	✓	✓	281
9WG1224F101-E	9WG1224F102-E	9WG1224F101-E	9WG1224F1D01-E	—	120×120×38mm	No	✓	✓	✓	281
9WG1224G101-E	9WG1224G102-E	9WG1224G101-E	9WG1224G1D01-E	—	120×120×38mm	No	✓	✓	✓	281
9WG1224H101-E	9WG1224H102-E	9WG1224H101-E	9WG1224H1D01-E	—	120×120×38mm	No	✓	✓	✓	281
9WG1224M101-E	9WG1224M102-E	9WG1224M101-E	—	—	120×120×38mm	No	✓	✓	✓	281
9WG1248E101-E	9WG1248E102-E	9WG1248E101-E	—	—	120×120×38mm	No	✓	✓	✓	281
9WG1248F101-E	9WG1248F102-E	9WG1248F101-E	—	—	120×120×38mm	No	✓	✓	✓	281
9WG1248G101-E	9WG1248G102-E	9WG1248G101-E	—	—	120×120×38mm	No	✓	✓	✓	281
9WG1248H101-E	9WG1248H102-E	9WG1248H101-E	9WG1248H1D01-E	—	120×120×38mm	No	✓	✓	✓	281
9WG1248M101-E	9WG1248M102-E	9WG1248M101-E	—	—	120×120×38mm	No	✓	✓	✓	281
9WG5748P5G001	9WG5748G5002	—	—	9WG5748P5G001	φ 172mm×150mm×51mm	No	✓	✓	✓	289
9WG5748P5H001	—	9WG5748H5001	9WG5748H5D001	9WG5748P5H001	φ 172mm×150mm×51mm	No	✓	✓	✓	289
9WL0412P3G001	—	9WL0412G3001	—	9WL0412P3G001	40×40×28mm	No	✓	✓	✓	248
9WL0412P3J001	9WL0412J3002	9WL0412J3001	—	9WL0412P3J001	40×40×28mm	No	✓	✓	✓	248
9WL0424P3G001	9WL0424G3002	9WL0424G3001	—	9WL0424P3G001	40×40×28mm	No	✓	✓	✓	248
9WL0424P3J001	9WL0424J3002	9WL0424J3001	—	9WL0424P3J001	40×40×28mm	No	✓	✓	✓	248
9WL0612P4H001	—	—	—	9WL0612P4H001	60×60×25mm	No	✓	✓	✓	251
9WL0612P4J001	9WL0612J4002	—	9WL0612J4D001	9WL0612P4J001	60×60×25mm	No	✓	✓	✓	251
9WL0612P4S001	9WL0612S4002	—	9WL0612S4D001	9WL0612P4S001	60×60×25mm	No	✓	✓	✓	251
9WL0624P4H001	—	—	—	9WL0624P4H001	60×60×25mm	No	✓	✓	✓	251
9WL0624P4J001	—	—	—	9WL0624P4J001	60×60×25mm	No	✓	✓	✓	251
9WL0624P4S001	—	—	—	9WL0624P4S001	60×60×25mm	No	✓	✓	✓	251
9WL0812P4G001	—	—	9WL0812G4D001	9WL0812P4G001	80×80×25mm	No	✓	✓	✓	257

Models listed in the main section of this catalog	List of models (models not listed in the main section of this catalog are options. Standards for optional model numbers may differ from the certified standards listed at right. Contact us for details of models with "-" model numbers.)				Frame Size	Rib	Standard (certification status is for the models listed in this catalog, and standards for optional model numbers may differ.)			page
	Without sensor	With pulse sensor	With lock sensor	With PWM control function and pulse sensor			UL	CSA	TÜV	
							(cUL)	(cUL)		
9WL0812P4H001	—	—	—	9WL0812P4H001	80×80×25mm	No	✓	✓	✓	257
9WL0812P4J001	—	—	—	9WL0812P4J001	80×80×25mm	No	✓	✓	✓	257
9WL0824P4G001	—	—	—	9WL0824P4G001	80×80×25mm	No	✓	✓	✓	257
9WL0824P4H001	—	—	—	9WL0824P4H001	80×80×25mm	No	✓	✓	✓	257
9WL0824P4J001	—	—	—	9WL0824P4J001	80×80×25mm	No	✓	✓	✓	257
9WL0912P4G001	—	—	—	9WL0912P4G001	92×92×25mm	No	✓	✓	✓	267
9WL0912P4H001	—	—	—	9WL0912P4H001	92×92×25mm	No	✓	✓	✓	267
9WL0912P4J001	9WL0912J4002	—	—	9WL0912P4J001	92×92×25mm	No	✓	✓	✓	267
9WL0912P4S001	—	—	—	9WL0912P4S001	92×92×25mm	No	✓	✓	✓	267
9WL0924P4H001	—	—	—	9WL0924P4H001	92×92×25mm	No	✓	✓	✓	267
9WL0924P4J001	—	—	—	9WL0924P4J001	92×92×25mm	No	✓	✓	✓	267
9WL0924P4S001	—	—	—	9WL0924P4S001	92×92×25mm	No	✓	✓	✓	267
9WP0412F6001	9WP0412F6002	9WP0412F6001	—	—	40×40×20mm	Yes	✓	✓	✓	247
9WP0412H6001	9WP0412H6002	9WP0412H6001	—	—	40×40×20mm	Yes	✓	✓	✓	247
9WP0612D401	9WP0612D402	9WP0612D401	9WP0612D4D01	—	60×60×25mm	Yes	✓	✓	✓	255
9WP0612D4011	—	9WP0612D4011	9WP0612D4D011	—	60×60×25mm	No	✓	✓	✓	255
9WP0612G401	9WP0612G402	9WP0612G401	9WP0612G4D01	9WP0612P4G01	60×60×25mm	Yes	✓	✓	✓	255
9WP0612G4011	9WP0612G4021	9WP0612G4011	—	—	60×60×25mm	No	✓	✓	✓	255
9WP0612H401	9WP0612H402	9WP0612H401	9WP0612H4D01	—	60×60×25mm	Yes	✓	✓	✓	255
9WP0612H4011	9WP0612H4021	9WP0612H4011	9WP0612H4D011	—	60×60×25mm	No	✓	✓	✓	255
9WP0624G401	9WP0624G402	9WP0624G401	9WP0624G4D01	—	60×60×25mm	Yes	✓	✓	✓	255
9WP0624G4011	—	9WP0624G4011	—	—	60×60×25mm	No	✓	✓	✓	255
9WP0624H401	9WP0624H402	9WP0624H401	9WP0624H4D01	—	60×60×25mm	Yes	✓	✓	✓	255
9WP0624H4011	9WP0624H4021	9WP0624H4011	9WP0624H4D011	—	60×60×25mm	No	✓	✓	✓	255
9WP0624J401	9WP0624J402	9WP0624J401	—	—	60×60×25mm	Yes	✓	✓	✓	255
9WP0624J4011	—	—	—	—	60×60×25mm	No	✓	✓	✓	255
9WP0648H401	9WP0648H402	9WP0648H401	9WP0648H4D01	—	60×60×25mm	Yes	✓	✓	✓	255
9WP0648H4011	9WP0648H4021	9WP0648H4011	9WP0648H4D011	—	60×60×25mm	No	✓	✓	✓	255
9WP0812G401	9WP0812G402	9WP0812G401	9WP0812G4D01	9WP0812P4G01	80×80×25mm	Yes	✓	✓	✓	261
9WP0812G4011	9WP0812G4021	9WP0812G4011	9WP0812G4D011	—	80×80×25mm	No	✓	✓	✓	261
9WP0812H401	9WP0812H402	9WP0812H401	9WP0812H4D01	—	80×80×25mm	Yes	✓	✓	✓	261
9WP0812H4011	9WP0812H4021	9WP0812H4011	9WP0812H4D011	—	80×80×25mm	No	✓	✓	✓	261
9WP0824H401	9WP0824H402	9WP0824H401	9WP0824H4D01	—	80×80×25mm	Yes	✓	✓	✓	261
9WP0824H4011	9WP0824H4021	9WP0824H4011	9WP0824H4D011	—	80×80×25mm	No	✓	✓	✓	261
9WP0824S401	9WP0824S402	9WP0824S401	9WP0824S4D01	—	80×80×25mm	Yes	✓	✓	✓	261
9WP0824S4011	—	9WP0824S4011	—	—	80×80×25mm	No	✓	✓	✓	261
9WP0848S401	9WP0848S402	9WP0848S401	9WP0848S4D01	—	80×80×25mm	Yes	✓	✓	✓	261
9WP0848S4011	9WP0848S4021	9WP0848S4011	9WP0848S4D011	—	80×80×25mm	No	✓	✓	✓	261
9WP0912F401	9WP0912F402	9WP0912F401	9WP0912F4D01	—	92×92×25mm	Yes	—	—	—	273
9WP0912F4011	—	—	—	—	92×92×25mm	No	—	—	—	273
9WP0912S401	—	9WP0912S401	9WP0912S4D01	—	92×92×25mm	Yes	—	—	—	273
9WP0912S4011	—	9WP0912S4011	—	—	92×92×25mm	No	—	—	—	273
9WP0924B401	9WP0924B402	9WP0924B401	9WP0924B4D01	—	92×92×25mm	Yes	✓	✓	✓	273
9WP0924B4011	9WP0924B4021	9WP0924B4011	9WP0924B4D011	—	92×92×25mm	No	✓	✓	✓	273
9WP0924F401	9WP0924F402	9WP0924F401	9WP0924F4D01	—	92×92×25mm	Yes	✓	✓	✓	273
9WP0924F4011	9WP0924F4021	9WP0924F4011	9WP0924F4D011	—	92×92×25mm	No	✓	✓	✓	273
9WP0924G401	9WP0924G402	9WP0924G401	9WP0924G4D01	—	92×92×25mm	Yes	✓	✓	✓	273
9WP0924G4011	—	9WP0924G4011	—	—	92×92×25mm	No	✓	✓	✓	273
9WP0924H401	9WP0924H402	9WP0924H401	9WP0924H4D01	—	92×92×25mm	Yes	✓	✓	✓	273
9WP0924H4011	—	—	—	—	92×92×25mm	No	✓	✓	✓	273
9WP0924S401	9WP0924S402	9WP0924S401	9WP0924S4D01	—	92×92×25mm	Yes	—	—	—	273
9WP0924S4011	—	—	—	—	92×92×25mm	No	✓	✓	✓	273
9WP1212H101	9WP1212H102	9WP1212H101	9WP1212H1D01	—	120×120×38mm	Yes	✓	✓	✓	279
9WP1212H1011	9WP1212H1021	9WP1212H1011	9WP1212H1D011	—	120×120×38mm	No	✓	✓	✓	279
9WP1212L101	—	9WP1212L101	—	—	120×120×38mm	Yes	✓	✓	✓	279
9WP1212L1011	—	—	—	—	120×120×38mm	No	✓	✓	✓	279
9WP1224H101	9WP1224H102	9WP1224H101	9WP1224H1D01	—	120×120×38mm	Yes	✓	✓	✓	279
9WP1224H1011	9WP1224H1021	9WP1224H1011	9WP1224H1D011	—	120×120×38mm	No	✓	✓	✓	279
9WP1248H101	9WP1248H102	9WP1248H101	9WP1248H1D01	—	120×120×38mm	Yes	✓	✓	✓	279
9WP1248H1011	9WP1248H1021	9WP1248H1011	9WP1248H1D011	—	120×120×38mm	No	✓	✓	✓	279
9WS0812F401	9WS0812F402	9WS0812F401	9WS0812F4D01	—	80×80×25mm	Yes	✓	✓	✓	263
9WS0812F4011	9WS0812F4021	9WS0812F4011	—	—	80×80×25mm	No	✓	✓	✓	263

Please contact your point of sale regarding low-speed sensors.

Models listed in the main section of this catalog	List of models (models not listed in the main section of this catalog are options. Standards for optional model numbers may differ from the certified standards listed at right. Contact us for details of models with "-" model numbers.)				Frame Size	Rib	Standard (certification status is for the models listed in this catalog, and standards for optional model numbers may differ.)			page
	Without sensor	With pulse sensor	With lock sensor	With PWM control function and pulse sensor			UL (cUL)	CSA (cUL)	TÜV	
							✓	✓	✓	
9WS0812H401	9WS0812H402	9WS0812H401	—	—	80×80×25mm	Yes	✓	✓	✓	263
9WS0812H4011	9WS0812H4021	9WS0812H4011	—	—	80×80×25mm	No	✓	✓	✓	263
9WS0812M401	9WS0812M402	9WS0812M401	9WS0812M4D01	—	80×80×25mm	Yes	✓	✓	✓	263
9WS0812M4011	9WS0812M4021	9WS0812M4011	—	—	80×80×25mm	No	✓	✓	✓	263
9WS0824F401	9WS0824F402	9WS0824F401	—	—	80×80×25mm	Yes	✓	✓	✓	263
9WS0824F4011	9WS0824F4021	9WS0824F4011	—	—	80×80×25mm	No	✓	✓	✓	263
9WS0824H401	9WS0824H402	9WS0824H401	9WS0824H4D01	—	80×80×25mm	Yes	✓	✓	✓	263
9WS0824H4011	9WS0824H4021	9WS0824H4011	—	—	80×80×25mm	No	✓	✓	✓	263
9WS0824M401	9WS0824M402	9WS0824M401	9WS0824M4D01	—	80×80×25mm	Yes	✓	✓	✓	263
9WS0824M4011	9WS0824M4021	9WS0824M4011	—	—	80×80×25mm	No	✓	✓	✓	263
9WS0912F401	9WS0912F402	9WS0912F401	9WS0912F4D01	—	92×92×25mm	Yes	✓	✓	✓	271
9WS0912H401	9WS0912H402	9WS0912H401	—	—	92×92×25mm	Yes	✓	✓	✓	271
9WS0912L401	9WS0912L402	9WS0912L401	—	—	92×92×25mm	Yes	✓	✓	✓	271
9WS0912M401	9WS0912M402	9WS0912M401	—	—	92×92×25mm	Yes	✓	✓	✓	271
9WS0924F401	9WS0924F402	9WS0924F401	—	—	92×92×25mm	Yes	✓	✓	✓	271
9WS0924H401	9WS0924H402	9WS0924H401	9WS0924H4D01	—	92×92×25mm	Yes	✓	✓	✓	271
9WS0924L401	9WS0924L402	9WS0924L401	—	—	92×92×25mm	Yes	✓	✓	✓	271
9WS0924M401	9WS0924M402	9WS0924M401	9WS0924M4D01	—	92×92×25mm	Yes	✓	✓	✓	271
9WS1212H101	9WS1212H102	9WS1212H101	—	—	120×120×38mm	Yes	✓	✓	✓	283
9WS1212H1011	9WS1212H1021	9WS1212H1011	—	—	120×120×38mm	No	✓	✓	✓	283
9WS1212M101	9WS1212M102	9WS1212M101	—	—	120×120×38mm	Yes	✓	✓	✓	283
9WS1212M1011	9WS1212M1021	9WS1212M1011	—	—	120×120×38mm	No	✓	✓	✓	283
9WS1224H101	9WS1224H102	9WS1224H101	—	—	120×120×38mm	Yes	✓	✓	✓	283
9WS1224H1011	9WS1224H1021	9WS1224H1011	—	—	120×120×38mm	No	✓	✓	✓	283
9WS1224M101	9WS1224M102	9WS1224M101	—	—	120×120×38mm	Yes	✓	✓	✓	283
9WS1224M1011	9WS1224M1021	9WS1224M1011	—	—	120×120×38mm	No	✓	✓	✓	283
9WS1248H101	9WS1248H102	9WS1248H101	9WS1248H1D01	—	120×120×38mm	Yes	✓	✓	✓	283
9WS1248H1011	9WS1248H1021	9WS1248H1011	9WS1248H1D011	—	120×120×38mm	No	✓	✓	✓	283
9WS1248M101	9WS1248M102	9WS1248M101	9WS1248M1D01	—	120×120×38mm	Yes	✓	✓	✓	283
9WS1248M1011	9WS1248M1021	9WS1248M1011	9WS1248M1D011	—	120×120×38mm	No	✓	✓	✓	283
9WV0812P1M001	—	9WV0812M1001	9WV0812M1D001	9WV0812P1M001	80×80×38mm	Yes	✓	✓	✓	265
9WV0848P1H001	—	—	—	9WV0848P1H001	80×80×38mm	Yes	✓	✓	✓	265
9WV0848P1H0011	—	—	—	9WV0848P1H0011	80×80×38mm	No	✓	✓	✓	265
9WV0924P1H001	—	—	—	9WV0924P1H001	92×92×38mm	Yes	✓	✓	✓	275
9WV0948P1H001	—	—	—	9WV0948P1H001	92×92×38mm	Yes	✓	✓	✓	275
9WV1212P1J001	9WV1212J1002	—	—	9WV1212P1J001	120×120×38mm	No	✓	✓	✓	277
9WV1224P1H001	9WV1224H102	9WV1224H101	9WV1224H1D001	9WV1224P1H001	120×120×38mm	No	✓	✓	✓	277
9WV1224P1J601	—	9WV1224J1001	—	9WV1224P1J601	120×120×38mm	No	✓	✓	✓	277
9WV1248P1J001	9WV1248J1002	9WV1248J1001	9WV1248J1D001	9WV1248P1J001	120×120×38mm	No	✓	✓	✓	277

Please contact your point of sale regarding low-speed sensors.

Index by Model No./Safety Standards List - ACDC Fans AC

Models listed in the main section of this catalog	Frame Size	Model	Rated Voltage [V]	UL (cUL)	CSA (cUL)	TÜV	CE	PSE	Note	page
9AD0901H12	92×92×38mm	San Ace 92AD	100 to 240	✓	✓	✓	✓	✓	Ribbed	413
9AD0901H121	92×92×38mm	San Ace 92AD	100 to 240	✓	✓	✓	✓	✓	Ribless	413
9AD0901H1H	92×92×38mm	San Ace 92AD	100 to 240	✓	✓	✓	✓	✓	Ribbed	413
9AD0901H1H1	92×92×38mm	San Ace 92AD	100 to 240	✓	✓	✓	✓	✓	Ribless	413
9AD0901M12	92×92×38mm	San Ace 92AD	100 to 240	✓	✓	✓	✓	✓	Ribbed	413
9AD0901M121	92×92×38mm	San Ace 92AD	100 to 240	✓	✓	✓	✓	✓	Ribless	413
9AD0901M1H	92×92×38mm	San Ace 92AD	100 to 240	✓	✓	✓	✓	✓	Ribbed	413
9AD0901M1H1	92×92×38mm	San Ace 92AD	100 to 240	✓	✓	✓	✓	✓	Ribless	413
9AD1201H12	120×120×38mm	San Ace 120AD	100 to 240	✓	✓	✓	✓	✓	Ribbed	417
9AD1201H121	120×120×38mm	San Ace 120AD	100 to 240	✓	✓	✓	✓	✓	Ribless	417
9AD1201H1H	120×120×38mm	San Ace 120AD	100 to 240	✓	✓	✓	✓	✓	Ribbed	417
9AD1201H1H1	120×120×38mm	San Ace 120AD	100 to 240	✓	✓	✓	✓	✓	Ribless	417

Please contact your point of sale for pulse sensors and lock sensors.

Index by Model No./Safety Standards List - AC Fans AC

Models listed in the main section of this catalog	Frame Size	Model	Rated Voltage [V]	UL	CSA	TÜV	CE	PSE	Note	page
109-033UL	80×80×42mm	San Ace 80	115	✓	✓	✓	✓	✓		433
109-040UL	80×80×42mm	San Ace 80	100	✓	✓	✓	✓	✓		433
109-041UL	80×80×42mm	San Ace 80	200	✓	✓	✓	✓	✓		433
109-043UL	80×80×42mm	San Ace 80	115	✓	✓	✓	✓	✓		433
109-044UL	80×80×42mm	San Ace 80	230	✓	✓	✓	✓	✓		433
109-047UL	80×80×42mm	San Ace 80	100	✓	✓	✓	✓	✓		433
109-130	60×60×38mm	San Ace 60	100	✓	—	✓	✓	—		425
109-133	60×60×38mm	San Ace 60	115	✓	—	✓	✓	—		425
109-150	80×80×38mm	San Ace 80	100	✓	✓	✓	✓	✓		431
109-151	80×80×38mm	San Ace 80	200	✓	✓	✓	✓	✓		431
109-153	80×80×38mm	San Ace 80	115	✓	✓	✓	✓	✓		431
109-154	80×80×38mm	San Ace 80	230	✓	✓	✓	✓	✓		431
109-180	60×60×28mm	San Ace 60	100	✓	—	✓	✓	—		423
109-183	60×60×28mm	San Ace 60	115	✓	—	✓	✓	—		423
109-210	80×80×20mm	San Ace 80	100	✓	✓	✓	✓	—		427
109-213	80×80×20mm	San Ace 80	115	✓	✓	✓	✓	—		427
109-311	φ 172mm×51mm (Round type)	San Ace 172	100	✓	✓	✓	✓	✓		451
109-312	φ 172mm×51mm (Round type)	San Ace 172	200	✓	✓	✓	✓	✓		451
109-313	φ 172mm×51mm (Round type)	San Ace 172	230	✓	✓	✓	✓	✓		451
109-314	φ 172mm×51mm (Round type)	San Ace 172	115	✓	✓	✓	✓	✓		451
109-371	φ 172mm×51mm (with sensor)	San Ace 172	100	✓	—	✓	✓	✓		451
109-372	φ 172mm×51mm (with sensor)	San Ace 172	200	✓	—	✓	✓	✓		451
109-373	φ 172mm×51mm (with sensor)	San Ace 172	230	✓	—	✓	✓	✓		451
109-374	φ 172mm×51mm (with sensor)	San Ace 172	115	✓	—	✓	✓	✓		451
109-601	160×160×51mm	San Ace 160	100	✓	✓	✓	✓	✓		447
109-602	160×160×51mm	San Ace 160	200	✓	✓	✓	✓	✓		447
109-603	160×160×51mm	San Ace 160	230	✓	✓	✓	✓	✓		447
109-604	160×160×51mm	San Ace 160	115	✓	✓	✓	✓	✓		447
109-641	160×160×51mm (with sensor)	San Ace 160	100	✓	—	✓	✓	✓		447
109-642	160×160×51mm (with sensor)	San Ace 160	200	✓	—	✓	✓	✓		447
109-643	160×160×51mm (with sensor)	San Ace 160	230	✓	—	✓	✓	✓		447
109-644	160×160×51mm (with sensor)	San Ace 160	115	✓	—	✓	✓	✓		447
109S005	120×120×38mm	San Ace 120	100	—	—	—	—	✓		443
109S005UL	120×120×38mm	San Ace 120	100	✓	✓	✓	✓	✓		443
109S006	120×120×38mm	San Ace 120	100	—	—	—	—	✓		443
109S006UL	120×120×38mm	San Ace 120	100/115	✓	✓	✓	✓	✓		443
109S008	120×120×38mm	San Ace 120	200	—	—	—	—	✓		443
109S008UL	120×120×38mm	San Ace 120	200	✓	✓	✓	✓	✓		443
109S010	120×120×38mm	San Ace 120	200	—	—	—	—	✓		443
109S010UL	120×120×38mm	San Ace 120	200/240	✓	✓	✓	✓	✓		443
109S013	120×120×38mm	San Ace 120	100	—	—	—	—	✓		443
109S013UL	120×120×38mm	San Ace 120	100	✓	✓	✓	✓	✓		443
109S024	120×120×38mm	San Ace 120	120	—	—	—	—	✓		443
109S024UL	120×120×38mm	San Ace 120	115	✓	✓	✓	✓	✓		443
109S025	120×120×38mm	San Ace 120	230	—	—	—	—	✓		443
109S025UL	120×120×38mm	San Ace 120	230	✓	✓	✓	✓	✓		443
109S029UL	120×120×38mm	San Ace 120	100	✓	✓	✓	✓	✓		443

Models listed in the main section of this catalog	Frame Size	Model	Rated Voltage [V]	UL	CSA	TÜV	CE	PSE	Note	page
109S030	80×80×25mm	San Ace 80	100	✓	✓	✓	✓	✓		429
109S031	80×80×25mm	San Ace 80	200	✓	✓	✓	✓	✓		429
109S033	80×80×25mm	San Ace 80	115	✓	✓	✓	✓	✓		429
109S034	80×80×25mm	San Ace 80	230	✓	✓	✓	✓	✓		429
109S050	80×80×25mm	San Ace 80	100	✓	✓	✓	✓	✓		429
109S051	80×80×25mm	San Ace 80	200	✓	✓	✓	✓	✓		429
109S053	80×80×25mm	San Ace 80	115	✓	✓	✓	✓	✓		429
109S054	80×80×25mm	San Ace 80	230	✓	✓	✓	✓	✓		429
109S072UL	120×120×38mm	San Ace 120	230	✓	✓	✓	✓	✓		443
109S074UL	120×120×38mm	San Ace 120	115	✓	✓	✓	✓	✓		443
109S075UL	120×120×38mm	San Ace 120	100	✓	✓	✓	✓	✓		443
109S078UL	120×120×38mm	San Ace 120	200	✓	✓	✓	✓	✓		443
109S081	120×120×25mm	San Ace 120	100	✓	✓	✓	✓	✓		439
109S082	120×120×25mm	San Ace 120	200	✓	✓	✓	✓	✓		439
109S083	120×120×25mm	San Ace 120	115	✓	✓	✓	✓	✓		439
109S084	120×120×25mm	San Ace 120	115	✓	✓	✓	✓	✓		439
109S085	120×120×25mm	San Ace 120	100	✓	✓	✓	✓	✓		439
109S086	120×120×25mm	San Ace 120	100	✓	✓	✓	✓	✓		439
109S087	120×120×25mm	San Ace 120	230	✓	✓	✓	✓	✓		439
109S088	120×120×25mm	San Ace 120	200	✓	✓	✓	✓	✓		439
109S089	120×120×25mm	San Ace 120	230	✓	✓	✓	✓	✓		439
109S091	92×92×25mm	San Ace 92	100	✓	✓	✓	✓	✓		435
109S092	92×92×25mm	San Ace 92	200	✓	✓	✓	✓	✓		435
109S093	92×92×25mm	San Ace 92	115	✓	✓	✓	✓	✓		435
109S094	92×92×25mm	San Ace 92	230	✓	✓	✓	✓	✓		435
109S095	92×92×25mm	San Ace 92	100	✓	✓	✓	✓	✓		435
109S096	92×92×25mm	San Ace 92	100	✓	✓	✓	✓	✓		435
109S192	92×92×25mm	San Ace 92	200	✓	✓	✓	✓	✓		435
109S193	92×92×25mm	San Ace 92	115	✓	✓	✓	✓	✓		435
109S194	92×92×25mm	San Ace 92	230	✓	✓	✓	✓	✓		435
109S301	φ172mm×150mm×51mm (Sidecut type)	San Ace 172	100	✓	✓	✓	✓	✓		449
109S302	φ172mm×150mm×51mm (Sidecut type)	San Ace 172	200	✓	✓	✓	✓	✓		449
109S303	φ172mm×150mm×51mm (Sidecut type)	San Ace 172	230	✓	✓	✓	✓	✓		449
109S304	φ172mm×150mm×51mm (Sidecut type)	San Ace 172	115	✓	✓	✓	✓	✓		449
109S405UL	120×120×38mm (with sensor)	San Ace 120	100	✓	—	✓	✓	✓		443
109S406UL	120×120×38mm (with sensor)	San Ace 120	100	✓	—	✓	✓	✓		443
109S408UL	120×120×38mm (with sensor)	San Ace 120	200	✓	—	✓	✓	✓		443
109S424UL	120×120×38mm (with sensor)	San Ace 120	115	✓	—	✓	✓	✓		443
109S425UL	120×120×38mm (with sensor)	San Ace 120	230	✓	—	✓	✓	✓		443
109S429UL	120×120×38mm (with sensor)	San Ace 120	100	✓	—	✓	✓	✓		443
109S472UL	120×120×38mm (with sensor)	San Ace 120	230	✓	—	✓	✓	✓		443
109S474UL	120×120×38mm (with sensor)	San Ace 120	115	✓	—	✓	✓	✓		443
109S475UL	120×120×38mm (with sensor)	San Ace 120	100	✓	—	✓	✓	✓		443
109S478UL	120×120×38mm (with sensor)	San Ace 120	200	✓	—	✓	✓	✓		443
109S484	120×120×25mm (with sensor)	San Ace 120	115	✓	—	✓	✓	✓		439
109S485	120×120×25mm (with sensor)	San Ace 120	100	✓	—	✓	✓	✓		439
109S486	120×120×25mm (with sensor)	San Ace 120	100	✓	—	✓	✓	✓		439
109S487	120×120×25mm (with sensor)	San Ace 120	230	✓	—	✓	✓	✓		439
109S488	120×120×25mm (with sensor)	San Ace 120	200	✓	—	✓	✓	✓		439
109S491	92×92×25mm (with sensor)	San Ace 92	100	✓	—	✓	✓	✓		435
109S492	92×92×25mm (with sensor)	San Ace 92	200	✓	—	✓	✓	✓		435
109S493	92×92×25mm (with sensor)	San Ace 92	115	✓	—	✓	✓	✓		435
109S494	92×92×25mm (with sensor)	San Ace 92	230	✓	—	✓	✓	✓		435
109S495	92×92×25mm (with sensor)	San Ace 92	100	✓	—	✓	✓	✓		435
109S496	92×92×25mm (with sensor)	San Ace 92	100	✓	—	✓	✓	✓		435

Index by Model No. - Options

■ Finger Guards **DC** **AC**

Model No.	Category	Matching Fan Size	page
109-019C	Finger Guards	120mm sq. type	470
109-019E	Finger Guards	120mm sq. type	471
109-019H	Finger Guards	120mm sq. type	470
109-019K	Finger Guards	120mm sq. type	471
109-049C	Finger Guards	80mm sq. type	470
109-049E	Finger Guards	80mm sq. type	470
109-049H	Finger Guards	80mm sq. type	470
109-059	Finger Guards	40mm sq. type	470
109-059H	Finger Guards	40mm sq. type	470
109-099C	Finger Guards	92mm sq. type	470
109-099E	Finger Guards	92mm sq., ϕ 100mm type	470
109-099H	Finger Guards	92mm sq., ϕ 100mm type	470
109-1050	Finger Guards	36mm sq. type	470
109-1051	Finger Guards	150mm sq. type	471
109-1052	Finger Guards	150mm sq. type	471
109-1065	Finger Guards	38mm sq. type	470
109-1066	Finger Guards	ϕ 172mm type	472
109-1068	Finger Guards	ϕ 172mm type	472
109-1102	Finger Guards	ϕ 200mm type	472
109-1103	Finger Guards	ϕ 200mm type	473
109-1104	Finger Guards	ϕ 150mm type	471
109-1104H	Finger Guards	ϕ 150mm type	471
109-1112	Finger Guards	ϕ 133mm type	471
109-1128	Finger Guards	72mm sq. type	470
109-1137	Finger Guards	ϕ 225mm type	473
109-1138	Finger Guards	ϕ 221mm type	473
109-1139	Finger Guards	ϕ 136mm type	471
109-1146	Finger Guards	270mm sq. type	472
109-139E	Finger Guards	60mm sq. type	470
109-139H	Finger Guards	60mm sq. type	470
109-149	Finger Guards	52mm sq. type	470
109-149E	Finger Guards	52mm sq. type	470
109-319E	Finger Guards	ϕ 172mm type	472
109-319H	Finger Guards	ϕ 172mm type	472
109-319J	Finger Guards	ϕ 172mm type	472
109-320	Finger Guards	ϕ 172mm type	472
109-619E	Finger Guards	160mm sq. type	471
109-619H	Finger Guards	160mm sq. type	471
109-620	Finger Guards	160mm sq. type	471
109-719	Finger Guards	140mm sq. type	471
109-719H	Finger Guards	140mm sq. type	471
109-720	Finger Guards	ϕ 200mm type	473
109-720H	Finger Guards	ϕ 200mm type	473
109-721	Finger Guards	ϕ 200mm type	473
109-721H	Finger Guards	ϕ 200mm type	473
109-722	Finger Guards	127mm sq., ϕ 175mm type	471
109-723	Finger Guards	127mm sq. type	471

■ Resin Finger Guards/Resin Filter Kits **DC** **AC**

Model No.	Category	Matching Fan Size	page
109-1000F13	Resin Filter Kits	120mm sq. type	475
109-1000F20	Resin Filter Kits	120mm sq. type	475
109-1000F30	Resin Filter Kits	120mm sq. type	475
109-1000F40	Resin Filter Kits	120mm sq. type	475
109-1001F13	Resin Filter Kits	92mm sq. type	475
109-1001F20	Resin Filter Kits	92mm sq. type	475
109-1001F30	Resin Filter Kits	92mm sq. type	475
109-1001F40	Resin Filter Kits	92mm sq. type	475
109-1002F13	Resin Filter Kits	80mm sq. type	475
109-1002F20	Resin Filter Kits	80mm sq. type	475
109-1002F30	Resin Filter Kits	80mm sq. type	475
109-1002F40	Resin Filter Kits	80mm sq. type	475
109-1003F13	Resin Filter Kits	60mm sq. type	475
109-1003F20	Resin Filter Kits	60mm sq. type	475
109-1003F30	Resin Filter Kits	60mm sq. type	475
109-1003F40	Resin Filter Kits	60mm sq. type	475
109-1000G	Resin Finger Guards	120mm sq. type	475
109-1001G	Resin Finger Guards	92mm sq. type	475
109-1002G	Resin Finger Guards	80mm sq. type	475
109-1003G	Resin Finger Guards	60mm sq. type	475

■ Replacement filter **DC** **AC**

Model No.	Category	Matching Fan Size	page
109-1000M13	Replacement filter	120mm sq. type	475
109-1000M20	Replacement filter	120mm sq. type	475
109-1000M30	Replacement filter	120mm sq. type	475
109-1000M40	Replacement filter	120mm sq. type	475
109-1001M13	Replacement filter	92mm sq. type	475
109-1001M20	Replacement filter	92mm sq. type	475
109-1001M30	Replacement filter	92mm sq. type	475
109-1001M40	Replacement filter	92mm sq. type	475
109-1002M13	Replacement filter	80mm sq. type	475
109-1002M20	Replacement filter	80mm sq. type	475
109-1002M30	Replacement filter	80mm sq. type	475
109-1002M40	Replacement filter	80mm sq. type	475
109-1003M13	Replacement filter	60mm sq. type	475
109-1003M20	Replacement filter	60mm sq. type	475
109-1003M30	Replacement filter	60mm sq. type	475
109-1003M40	Replacement filter	60mm sq. type	475

■ EMC guards/Inlet nozzle for centrifugal fan and splash proof centrifugal fan **DC**

Model No.	Category	Matching Fan Size	page
109-1036	EMC guards	φ 172mm type	474
109-1037	EMC guards	120mm sq. type	474
109-1038	EMC guards	80mm sq. type	474
109-1039	EMC guards	80mm sq. type	474
109-1040	EMC guards	92mm sq. type	474
109-1069	Inlet nozzle for centrifugal fan and splash proof centrifugal fan	φ 133mm type	473
109-1069H	Inlet nozzle for centrifugal fan and splash proof centrifugal fan	φ 133mm type	473
109-1073	Inlet nozzle for centrifugal fan and splash proof centrifugal fan	φ 175mm type	474
109-1073H	Inlet nozzle for centrifugal fan and splash proof centrifugal fan	φ 175mm type	474
109-1080	Inlet nozzle for centrifugal fan and splash proof centrifugal fan	φ 100mm type	473
109-1081	Inlet nozzle for centrifugal fan and splash proof centrifugal fan	φ 150mm type	474
109-1081H	Inlet nozzle for centrifugal fan and splash proof centrifugal fan	φ 150mm type	474
109-1134	Inlet nozzle for centrifugal fan and splash proof centrifugal fan	φ 225mm type	474
109-1135	Inlet nozzle for centrifugal fan and splash proof centrifugal fan	φ 221mm type	474

■ Plug Cord **AC**

Model No.	UL	CSA	PSE	Applicable model	page
489-006-L10			✓	120×120×38mm	477
489-006-L21			✓	120×120×38mm	477
489-006-L35			✓	120×120×38mm	477
489-007-L10	✓	✓		120×120×38mm	478
489-007-L21	✓	✓		120×120×38mm	478
489-008-L10			✓	80×80×42mm	477
489-008-L21			✓	80×80×42mm	477
489-008-L35			✓	80×80×42mm	477
489-016-L10			✓	120×120×25mm 92×92×25mm 80×80×25mm 80×80×38mm	477
489-016-L21			✓	120×120×25mm 92×92×25mm 80×80×25mm 80×80×38mm	477
489-037-L10			✓	120×120×38mm	477
489-037-L21			✓	120×120×38mm	477
489-037-L35			✓	120×120×38mm	477
489-047-L10	✓	✓		120×120×25mm 92×92×25mm 80×80×25mm 80×80×38mm	478
489-047-L21	✓	✓		120×120×25mm 92×92×25mm 80×80×25mm 80×80×38mm	478
489-084-L10	✓	✓		φ 172×51mm φ 172×150×51mm 160×160×51mm	478
489-084-L21	✓	✓		φ 172×51mm φ 172×150×51mm 160×160×51mm	478
489-086-L10	✓	✓		160×160×51mm	478
489-086-L21	✓	✓		160×160×51mm	478
489-1618-L10			✓	160×160×51mm	477
489-1618-L21			✓	160×160×51mm	477
489-1618-L28			✓	160×160×51mm	477
489-1619-L10			✓	φ 172×51mm φ 172×150×51mm 160×160×51mm	477
489-1619-L21			✓	φ 172×51mm φ 172×150×51mm 160×160×51mm	477
489-1635-L10	✓	✓	✓	ACDC Fan	478
489-1635-L21	✓	✓	✓	ACDC Fan	478

Recommended connectors for DC fans ····· 479p

Deleted Models in this Catalog

Following models were deleted in this latest version of catalog. However, these models are not discontinued product. Please contact us for further assistance if necessary.

■ DC Fan

Size	Model No.	Frame material	Rated Voltage [V]	Operating Voltage Range [V]	Rated Current [A]	Rated Input [W]	Rated Speed [min ⁻¹]	Max. Airflow [m ³ /min] [CFM]	Max. Static Pressure [Pa] [inchH ₂ O]	SPL [dB(A)]	Operating Temperature [°C]	Life Expectancy [h]
92 × 92 × 25mm	109P0912J401	Plastics	12	6 to 13.8	0.56	6.72	4,300	2.03 71.6	92.2 0.37	47	-20 to +60	40,000
92 × 92 × 25mm	109P0912W401	Plastics	12	6 to 16	0.21	2.52	2,850	1.45 51.2	45 0.181	33	-20 to +70	40,000
92 × 92 × 25mm	109P0912H401	Plastics	12	10.2 to 13.8	0.21	2.52	2,850	1.45 51.2	45 0.181	33	-20 to +70	40,000
92 × 92 × 25mm	109P0912F401	Plastics	12	10.2 to 13.8	0.14	1.68	2,450	1.24 43.8	32.3 0.130	30	-20 to +70	40,000
92 × 92 × 25mm	109P0912M401	Plastics	12	10.2 to 13.8	0.1	1.2	2,100	1.04 36.7	23.5 0.094	27	-20 to +70	40,000
92 × 92 × 25mm	109P0912L401	Plastics	12	10.2 to 13.8	0.07	0.84	1,700	0.8 28.3	16.6 0.067	23	-20 to +70	40,000
92 × 92 × 25mm	109P0924W401	Plastics	24	12 to 30	0.12	2.88	2,850	1.45 51.2	45 0.181	33	-20 to +70	40,000
92 × 92 × 25mm	109P0924H401	Plastics	24	20.4 to 27.6	0.12	2.88	2,850	1.45 51.2	45 0.181	33	-20 to +70	40,000
92 × 92 × 25mm	109P0924F401	Plastics	24	20.4 to 27.6	0.08	1.92	2,450	1.24 43.8	32.3 0.130	30	-20 to +70	40,000
92 × 92 × 25mm	109P0924M401	Plastics	24	20.4 to 27.6	0.06	1.44	2,100	1.04 36.7	23.5 0.094	27	-20 to +70	40,000
92 × 92 × 25mm	109P0924L401	Plastics	24	20.4 to 27.6	0.05	1.2	1,700	0.8 28.3	16.6 0.067	23	-20 to +70	40,000
92 × 92 × 25mm	109P0948H401	Plastics	48	43 to 53	0.06	2.88	2,850	1.45 51.2	45 0.181	33	-20 to +70	40,000
φ 200mm × 70mm	109E2024S001	Aluminum	24	21.6 to 26.4	1.9	45.6	3,200	10.45 369	287.1 1.153	57	-10 to +70	40,000
φ 200mm × 70mm	109E2024H001	Aluminum	24	20.4 to 27.6	1.0	24	2,600	8.2 289.5	192 0.771	51	-10 to +70	40,000
					1.9	45.6	3,200	10.45 369	287.1 1.153	57		
φ 200mm × 70mm	109E2024AS001	Aluminum	24	21.6 to 26.4	1.45	34.8	2,800	9 317.8	215.6 0.865	54	-10 to +70	40,000
					1.0	24	2,600	8.2 289.5	192 0.771	51		
φ 200mm × 70mm	109E2024MH001	Aluminum	24	20.4 to 27.6	0.63	15.12	2,100	6.7 236.6	115.4 0.463	45	-10 to +70	40,000
					1.0	24	2,600	8.2 289.5	192 0.771	51		

■ Counter Rotating Fan

Size	Model No.	Frame material	Rated Voltage [V]	Operating Voltage Range [V]	Rated Current [A]	Rated Input [W]	Rated Speed [min ⁻¹]	Max. Airflow [m ³ /min] [CFM]	Max. Static Pressure [Pa] [inchH ₂ O]	SPL [dB(A)]	Operating Temperature [°C]	Life Expectancy [h]
							Inlet Outlet					
40 × 40 × 56mm	9CRA0412K501	Plastics	12	10.8 to 12.6	1.8	21.6	17,000 13,000	0.95 33.5	650 2.61	65	-20 to +60	40,000
40 × 40 × 56mm	9CRA0412J501	Plastics	12	10.8 to 13.2	1.4	16.8	15,800 12,200	0.9 31.8	570 2.29	62	-20 to +70	40,000
40 × 40 × 56mm	9CRA0412G501	Plastics	12	10.8 to 13.2	1.0	12	14,000 10,400	0.77 27.2	435 1.75	59	-20 to +70	40,000
60 × 60 × 76mm	9CR0612S001	Plastics	12	10.8 to 13.2	3.2	38.4	11,500 7,000	2.26 80	550 2.21	66	-10 to +60	40,000
60 × 60 × 76mm	9CR0612H001	Plastics	12	10.8 to 13.2	2.7	32.4	10,300 6,500	1.98 70	450 1.81	64	-10 to +60	40,000
80 × 80 × 80mm	9CR0812S801	Plastics	12	10.8 to 13.2	5.5	66.0	8,000 5,300	4.53 160	520 2.09	71	-10 to +60	40,000
80 × 80 × 80mm	9CR0812H801	Plastics	12	10.8 to 13.2	3.6	43.2	7,000 4,600	3.97 140	400 1.61	68	-10 to +60	40,000

Size	Model No.	Frame material	Rated Voltage [V]	PWM Frequency [kHz]	Rated Current [A]	Rated Speed [min ⁻¹]		Max. Airflow [m ³ /min] [CFM]	Max. Static Pressure [Pa] [inchH ₂ O]	SPL [dB(A)]	Expected Life [h]
						Duty Cycle 0%	Duty Cycle 100%				
60 × 60 × 76mm	9CR0612P0S03	Plastics	12	25.0	3.2	Inlet : 1,300 outlet : 800	Inlet : 11,500 outlet : 7,000	2.26 79.8	550 2.21	66	40,000
	9CR0612P0H03	Plastics	12	25.0	2.7	Inlet : 1,200 outlet : 800	Inlet : 10,300 outlet : 6,500	1.98 69.91	450 1.81	64	40,000
80 × 80 × 80mm	9CR0848P8S03	Plastics	48	25.0	1.29	Inlet : 2,000 outlet : 1,300	Inlet : 8,000 outlet : 5,300	4.53 159.95	520 2.09	71	40,000

Deleted models in this catalog

■ Splash Proof Fan

Size	Model No.	Frame material	Rated Voltage [V]	Operating Voltage Range [V]	Rated Current [A]	Rated Input [W]	Rated Speed [min ⁻¹]	Max. Airflow [m ³ /min] [CFM]	Max. Static Pressure [Pa] [inchH ₂ O]	SPL [dB(A)]	Operating Temperature [°C]	Life Expectancy [h]
80 × 80 × 25mm	109W0812H401-U	Aluminum	12	10.2 to 13.8	0.18	2.16	3,000	1.06 37.4	39.2 0.157	32	- 10 to + 70	100,000
80 × 80 × 25mm	109W0812F401-U	Aluminum	12	10.2 to 13.8	0.14	1.68	2,700	0.93 32.8	32.3 0.130	29	- 10 to + 70	100,000
80 × 80 × 25mm	109W0812M401-U	Aluminum	12	10.2 to 13.8	0.10	1.20	2,400	0.83 29.3	26.5 0.106	26	- 10 to + 70	100,000
80 × 80 × 25mm	109W0812L401-U	Aluminum	12	10.2 to 13.8	0.08	0.96	1,900	0.63 22.2	16.67 0.067	22	- 10 to + 70	100,000
80 × 80 × 25mm	109W0824H401-U	Aluminum	24	20.4 to 27.6	0.09	2.16	3,000	1.06 37.4	39.2 0.157	32	- 10 to + 70	100,000
80 × 80 × 25mm	109W0824F401-U	Aluminum	24	20.4 to 27.6	0.08	1.92	2,700	0.93 32.8	32.3 0.130	29	- 10 to + 70	100,000
80 × 80 × 25mm	109W0824M401-U	Aluminum	24	20.4 to 27.6	0.07	1.68	2,400	0.83 29.3	26.5 0.106	26	- 10 to + 70	100,000
80 × 80 × 25mm	109W0824L401-U	Aluminum	24	20.4 to 27.6	0.05	1.20	1,900	0.63 22.2	16.67 0.067	22	- 10 to + 70	100,000
80 × 80 × 25mm	109W0848H401-U	Aluminum	48	40.8 to 55.2	0.06	2.88	3,150	1.10 38.8	43.1 0.173	34	- 10 to + 70	100,000
92 × 92 × 25mm	109W0912H401-U	Aluminum	12	10.2 to 13.8	0.21	2.52	2,850	1.38 48.7	45.1 0.181	33	- 10 to + 70	100,000
92 × 92 × 25mm	109W0912F401-U	Aluminum	12	10.2 to 13.8	0.14	1.68	2,450	1.18 41.7	32.3 0.130	30	- 10 to + 70	100,000
92 × 92 × 25mm	109W0912M401-U	Aluminum	12	10.2 to 13.8	0.11	1.32	2,100	1.01 35.7	23.5 0.094	27	- 10 to + 70	100,000
92 × 92 × 25mm	109W0912L401-U	Aluminum	12	10.2 to 13.8	0.08	0.96	1,700	0.80 28.2	16.7 0.067	23	- 10 to + 70	100,000
92 × 92 × 25mm	109W0924H401-U	Aluminum	24	20.4 to 27.6	0.12	2.88	2,850	1.38 48.7	45.1 0.181	33	- 10 to + 70	100,000
92 × 92 × 25mm	109W0924F401-U	Aluminum	24	20.4 to 27.6	0.08	1.92	2,450	1.18 41.7	32.3 0.130	30	- 10 to + 70	100,000
92 × 92 × 25mm	109W0924M401-U	Aluminum	24	20.4 to 27.6	0.06	1.44	2,100	1.01 35.7	23.5 0.094	27	- 10 to + 70	100,000
92 × 92 × 25mm	109W0924L401-U	Aluminum	24	20.4 to 27.6	0.05	1.20	1,700	0.80 28.2	16.7 0.067	23	- 10 to + 70	100,000
92 × 92 × 25mm	109W0948H401-U	Aluminum	48	40.8 to 55.2	0.06	2.88	2,850	1.38 48.7	45.1 0.181	33	- 10 to + 70	100,000

■ Long Life Fan

Size	Model No.	Frame material	Rated Voltage [V]	Operating Voltage Range [V]	Rated Current [A]	Rated Input [W]	Rated Speed [min ⁻¹]	Max. Airflow [m ³ /min] [CFM]	Max. Static Pressure [Pa] [inchH ₂ O]	SPL [dB(A)]	Operating Temperature [°C]	Life Expectancy [h]
60 × 60 × 25mm	109L0612G401	Aluminum	12	10.2 to 13.8	0.24	2.88	5,600	0.78 27.5	87.3 0.35	39	- 20 to + 70	100,000
60 × 60 × 25mm	109L0612S401	Aluminum	12	10.2 to 13.8	0.17	2.04	4,600	0.65 23.0	56.8 0.228	33	- 20 to + 70	100,000
60 × 60 × 25mm	109L0612H401	Aluminum	12	10.2 to 13.8	0.11	1.32	3,800	0.53 18.7	40.2 0.161	28	- 20 to + 70	100,000
60 × 60 × 25mm	109L0612F401	Aluminum	12	10.2 to 13.8	0.09	1.08	3,200	0.44 15.5	29.4 0.118	24	- 20 to + 70	100,000
60 × 60 × 25mm	109L0612M401	Aluminum	12	10.2 to 13.8	0.06	0.72	2,600	0.36 12.7	19.6 0.079	20	- 20 to + 70	100,000
60 × 60 × 25mm	109L0624D401	Aluminum	24	20.4 to 27.6	0.12	2.88	5,150	0.72 25.4	73.8 0.296	37	- 20 to + 70	100,000
60 × 60 × 25mm	109L0624S401	Aluminum	24	20.4 to 27.6	0.08	1.92	4,600	0.65 23.0	56.8 0.230	33	- 20 to + 70	100,000
60 × 60 × 25mm	109L0624H401	Aluminum	24	20.4 to 27.6	0.06	1.44	3,800	0.53 18.7	40.2 0.161	28	- 20 to + 70	100,000
60 × 60 × 25mm	109L0624F401	Aluminum	24	20.4 to 27.6	0.05	1.20	3,200	0.44 15.5	29.4 0.118	24	- 20 to + 70	100,000
60 × 60 × 25mm	109L0624M401	Aluminum	24	20.4 to 27.6	0.04	0.96	2,600	0.36 12.7	19.6 0.079	20	- 20 to + 70	100,000
60 × 60 × 25mm	109L0648G401	Aluminum	48	40.8 to 55.2	0.07	3.36	5,600	0.78 27.5	87.3 0.35	39	- 20 to + 60	80,000
60 × 60 × 25mm	109L0648H401	Aluminum	48	40 to 53	0.04	1.92	3,800	0.53 18.7	40.2 0.161	28	- 20 to + 70	100,000
80 × 80 × 25mm	109L0812S401	Aluminum	12	10.2 to 13.8	0.26	3.12	3,400	1.2 42.4	50 0.2	37	- 20 to + 70	100,000
80 × 80 × 25mm	109L0812H401	Aluminum	12	10.2 to 13.8	0.18	2.16	3,000	1.06 37.4	39.2 0.157	32	- 20 to + 70	100,000
80 × 80 × 25mm	109L0812F401	Aluminum	12	10.2 to 13.8	0.14	1.68	2,700	0.93 32.8	32.3 0.130	29	- 20 to + 70	100,000
80 × 80 × 25mm	109L0812M401	Aluminum	12	10.2 to 13.8	0.1	1.2	2,400	0.83 29.3	26.5 0.106	26	- 20 to + 70	100,000
80 × 80 × 25mm	109L0812L401	Aluminum	12	10.2 to 13.8	0.08	0.96	1,900	0.63 22.2	16.7 0.067	22	- 20 to + 70	100,000
80 × 80 × 25mm	109L0824S401	Aluminum	24	20.4 to 27.6	0.11	2.64	3,400	1.2 42.4	50 0.2	37	- 20 to + 70	100,000
80 × 80 × 25mm	109L0824H401	Aluminum	24	20.4 to 27.6	0.09	2.16	3,000	1.06 37.4	39.2 0.157	32	- 20 to + 70	100,000
80 × 80 × 25mm	109L0824F401	Aluminum	24	20.4 to 27.6	0.08	1.92	2,700	0.93 32.8	32.3 0.130	29	- 20 to + 70	100,000
80 × 80 × 25mm	109L0824M401	Aluminum	24	20.4 to 27.6	0.07	1.68	2,400	0.83 29.3	26.5 0.106	26	- 20 to + 70	100,000
80 × 80 × 25mm	109L0824L401	Aluminum	24	20.4 to 27.6	0.05	1.2	1,900	0.63 22.2	16.7 0.067	22	- 20 to + 70	100,000
80 × 80 × 25mm	109L0848H401	Aluminum	48	40.8 to 55.2	0.06	2.88	3,150	1.1 38.8	43.1 0.173	34	- 20 to + 70	100,000
92 × 92 × 25mm	109L0912S401	Aluminum	12	10.2 to 13.8	0.32	3.84	3,500	1.69 59.7	66.6 0.267	39	- 20 to + 70	100,000
92 × 92 × 25mm	109L0912H401	Aluminum	12	10.2 to 13.8	0.21	2.52	2,850	1.38 48.7	45.1 0.181	33	- 20 to + 70	100,000
92 × 92 × 25mm	109L0912F401	Aluminum	12	10.2 to 13.8	0.14	1.68	2,450	1.18 41.7	32.3 0.130	30	- 20 to + 70	100,000
92 × 92 × 25mm	109L0912M401	Aluminum	12	10.2 to 13.8	0.11	1.32	2,100	1.01 35.7	23.5 0.094	27	- 20 to + 70	100,000
92 × 92 × 25mm	109L0912L401	Aluminum	12	10.2 to 13.8	0.08	0.96	1,700	0.80 28.2	16.7 0.067	23	- 20 to + 70	100,000
92 × 92 × 25mm	109L0924H401	Aluminum	24	20.4 to 27.6	0.12	2.88	2,850	1.38 48.7	45.1 0.181	33	- 20 to + 70	100,000
92 × 92 × 25mm	109L0924F401	Aluminum	24	20.4 to 27.6	0.08	1.92	2,450	1.18 41.7	32.3 0.130	30	- 20 to + 70	100,000
92 × 92 × 25mm	109L0924M401	Aluminum	24	20.4 to 27.6	0.06	1.44	2,100	1.01 35.7	23.5 0.094	27	- 20 to + 70	100,000
92 × 92 × 25mm	109L0924L401	Aluminum	24	20.4 to 27.6	0.05	1.2	1,700	0.80 28.2	16.7 0.067	23	- 20 to + 70	100,000
92 × 92 × 25mm	109L0948C401	Aluminum	48	43 to 53	0.1	4.8	3,400	1.65 58.3	64.2 0.258	38	- 20 to + 70	80,000
92 × 92 × 25mm	109L0948H401	Aluminum	48	40.8 to 55.2	0.06	2.88	2,850	1.38 48.7	45.1 0.181	33	- 20 to + 70	100,000
120 × 120 × 38mm	9LB1212H101	Aluminum	12	10.2 to 13.8	0.39	4.68	2,600	2.9 102.4	67.62 0.272	39	- 20 to + 70	200,000
120 × 120 × 38mm	9LB1212M101	Aluminum	12	10.2 to 13.8	0.22	2.64	2,000	2.2 77.7	42.14 0.169	32	- 20 to + 70	200,000
120 × 120 × 38mm	9LB1224S101	Aluminum	24	20.4 to 27.6	0.46	11.04	3,500	3.88 137.0	120.8 0.485	48	- 20 to + 70	100,000
120 × 120 × 38mm	9LB1224H101	Aluminum	24	20.4 to 27.6	0.19	4.56	2,600	2.9 102.4	67.62 0.272	39	- 20 to + 70	200,000
120 × 120 × 38mm	9LB1224M101	Aluminum	24	20.4 to 27.6	0.11	2.64	2,000	2.2 77.7	42.14 0.169	32	- 20 to + 70	200,000
120 × 120 × 38mm	9LB1248H101	Aluminum	48	40.8 to 55.2	0.11	5.28	2,600	2.9 102.4	67.62 0.272	39	- 20 to + 70	200,000
120 × 120 × 38mm	9LB1248M101	Aluminum	48	40.8 to 55.2	0.06	2.88	2,000	2.2 77.7	42.14 0.169	32	- 20 to + 70	200,000

■ Thermally Controlled Fan

Size	Model No.	Frame material	Rated Voltage [V]	Operating Voltage Range [V]	Rated Current [A]	Rated Input [W]	Rated Speed [min ⁻¹]	Max. Airflow [m ³ /min] [CFM]	Max. Static Pressure [Pa] [inchH ₂ O]	SPL [dB(A)]	Operating Temperature [°C]	Life Expectancy [h]
52 × 52 × 15mm	109P0512T7H12	Plastics	12	10.2 to 13.8	0.13	1.56	4,600	0.255 9.0	31.9 0.128	27	- 10 to + 70	60,000
					0.09	1.08	2,300	0.13 4.6	8.8 0.035	17		
52 × 52 × 15mm	109P0512T7H122	Plastics	12	10.2 to 13.8	0.13	1.56	4,900	0.27 9.5	36.2 0.145	28	- 10 to + 70	60,000
					0.09	1.08	2,400	0.14 4.9	9.6 0.039	17		
60 × 60 × 15mm	109P0612T7H12	Plastics	12	10.2 to 13.8	0.12	1.44	4,100	0.4 14.1	38.2 0.153	32	- 10 to + 70	60,000
					0.08	0.96	2,050	0.2 7.1	9.3 0.037	18		
60 × 60 × 15mm	109P0612T7H122	Plastics	12	10.2 to 13.8	0.12	1.44	4,300	0.42 14.8	42.0 0.169	32	- 10 to + 70	60,000
					0.08	0.96	2,100	0.2 7.0	9.7 0.039	18		
60 × 60 × 20mm	109P0612T6H12	Plastics	12	10.2 to 13.8	0.15	1.8	4,200	0.42 14.8	31.9 0.128	31	- 10 to + 70	60,000
					0.10	1.2	2,100	0.21 7.4	8.8 0.035	21		
60 × 60 × 20mm	109P0612T6H122	Plastics	12	10.2 to 13.8	0.15	1.8	4,400	0.44 15.5	35.0 0.141	33	- 10 to + 70	60,000
					0.10	1.2	2,150	0.22 7.8	9.2 0.037	21		
60 × 60 × 25mm	109R0612T4H12 109R0612T4H121	Plastics	12	10.2 to 13.8	0.13	1.56	3,800	0.53 18.7	40.2 0.161	28	- 10 to + 60	60,000
					0.10	1.20	1,900	0.26 9.2	9.8 0.039	15		
60 × 60 × 25mm	109R0612T4H122 109R0612T4H123	Plastics	12	10.2 to 13.8	0.13	1.56	3,950	0.55 19.4	41.8 0.168	28	- 10 to + 60	60,000
					0.10	1.20	1,950	0.27 9.5	10.3 0.041	15		
80 × 80 × 20mm	109P0812T6H12	Plastics	12	10.2 to 13.8	0.18	2.16	2,900	0.84 29.7	29.4 0.118	31	- 10 to + 60	60,000
					0.1	1.2	1,450	0.42 14.8	7.4 0.030	20		
80 × 80 × 20mm	109P0812T6H122	Plastics	12	10.2 to 13.8	0.18	2.16	3,050	0.88 31.0	32.5 0.131	32	- 10 to + 60	60,000
					0.1	1.2	1,450	0.42 14.8	7.4 0.030	20		
80 × 80 × 25mm	109R0812T4H12 109R0812T4H121	Plastics	12	10.2 to 13.8	0.14	1.68	2,900	1.03 36.4	35.3 0.142	29	- 10 to + 60	60,000
					0.09	1.08	1,450	0.51 18.0	8.8 0.035	14		
80 × 80 × 25mm	109R0812T4H122 109R0812T4H123	Plastics	12	10.2 to 13.8	0.14	1.68	3,000	1.07 37.8	37.7 0.151	29	- 10 to + 60	60,000
					0.09	1.08	1,450	0.51 18.0	8.8 0.035	14		
92 × 92 × 25mm	109P0912T4H12 109P0912T4H121	Plastics	12	10.2 to 13.8	0.2	2.4	2,850	1.45 51.2	45.1 0.181	33	- 10 to + 60	40,000
					0.1	1.2	1,400	0.71 25.0	11.3 0.045	18		
92 × 92 × 25mm	109P0912T4H122 109P0912T4H123	Plastics	12	10.2 to 13.8	0.2	2.4	3,000	1.52 53.7	50.0 0.201	35	- 10 to + 60	40,000
					0.1	1.2	1,400	0.71 25.0	11.3 0.045	18		
120 × 120 × 25mm	109P1212T4H12 109P1212T4H121	Plastics	12	10.2 to 13.8	0.55	6.6	2,800	2.5 88.3	53.9 0.216	40	- 10 to + 60	40,000
					0.22	2.64	1,400	1.25 44.1	13.7 0.055	25		
120 × 120 × 25mm	109P1212T4H122 109P1212T4H123	Plastics	12	10.2 to 13.8	0.55	6.6	2,800	2.5 88.3	53.9 0.216	40	- 10 to + 60	40,000
					0.22	2.64	1,400	1.25 44.1	13.7 0.055	25		
120 × 120 × 38mm	109R1212T1H12 109R1212T1H121	Plastics	12	10.2 to 13.8	0.48	5.75	2,600	2.9 102.4	64.7 0.260	39	- 10 to + 60	40,000
					0.23	2.76	1,300	1.4 49.4	16.2 0.065	24		
120 × 120 × 38mm	109R1212T1H122 109R1212T1H123	Plastics	12	10.2 to 13.8	0.48	5.75	2,600	2.9 102.4	64.7 0.260	39	- 10 to + 60	40,000
					0.23	2.76	1,300	1.4 49.4	16.2 0.065	24		

■ Blower

Size	Model No.	Frame material	Rated Voltage [V]	Operating Voltage Range [V]	Rated Current [A]	Rated Input [W]	Rated Speed [min ⁻¹]	Max. Airflow [m ³ /min] [CFM]	Max. Static Pressure [Pa] [inchH ₂ O]	SPL [dB(A)]	Operating Temperature [°C]	Life Expectancy [h]
120 × 32mm	109BF12HC2	Plastics	12	10.2 to 13.8	0.6	7.2	2,400	0.78 27.5	175.4 0.704	52	- 20 to + 60	40,000
120 × 32mm	109BF12MC2	Plastics	12	10.2 to 13.8	0.32	3.84	1,900	0.61 21.5	109.8 0.441	44	- 20 to + 60	40,000
120 × 32mm	109BF24HC2	Plastics	24	20.4 to 27.6	0.3	7.2	2,400	0.78 27.5	175.4 0.704	52	- 20 to + 60	40,000
120 × 32mm	109BF24MC2	Plastics	24	20.4 to 27.6	0.16	3.84	1,900	0.61 21.5	109.8 0.441	44	- 20 to + 60	40,000

• Storage temperature is -30°C to +70°C .

Вентилятор sanyo denki san ace , Минск тел. +375447584780

www.fotorele.net www.tiristor.by радиодетали, электронные компоненты

email minsk17@tut.by tel.+375 29 758 47 80 МТС

каталог, описание, технические, характеристики, datasheet, параметры, маркировка, габариты, фото

QR код



9GT type

Wide Temperature Range Fan DC

These fans achieve an operating temperature range of -40°C to +85°C. They operate in a wide temperature range, serving in various applications where conventional fans could not be used. They are suitable for refrigerators and freezers, lighting devices, communications devices, PV inverters, and rapid EV charging stations.

40mm sq. to 120mm sq.
⇒pp. 359 to 370



9AD type

ACDC Fan AC

This fan operates by internally converting AC power into DC power. It provides the superior performance of a DC fan with the flexibility of AC input.

92x92x38mm
⇒pp. 413 to 416

120x120x38mm
⇒pp. 417 to 420



9RF type

Reversible Flow Fan DC

Multiple fans are usually used to blow air in both directions to ventilate houses, and to cool drink vending machines, and food display cases. With reversible flow fans, the wind direction can be switched so fewer fans are required.

φ136x28mm
⇒pp. 243 to 244

