

LIMIT SWITCHES

Выключатель концевой, путевой Минск т.80447584780

www.fotorele.net www.tiristor.by радиодетали, электронные компоненты

Документация

email minsk17@tut.by tel.+375 29 758 47 80 мтс

каталог, описание, технические, характеристики,

datasheet,

параметры,

маркировка,

габариты,

фото,

даташит



**1. PAP type limit switches
in plastic body** **138**



**2. PSP type limit switches
emergency stop, in plastic body** **145**



**3. PAM type limit switches
in metal body** **153**



**4. PBM type limit switches
in metal body** **158**



**5. PSBM type limit switches
emergency stop, in metal body** **170**



**6. PDM type limit switches
in metal body** **175**



**7. PDP type limit switches
in plastic body** **180**



**8. PEM1 type limit switches
in metal body** **185**



**9. PEM2 type limit switches
in metal body** **188**



**10. KLM type limit switches
in plastic body** **191**



**11. D type limit switches
in metal body** **193**

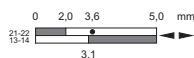

12. How to read operating diagrams **195**



13. Instruction manual **196**

PAP1 type limit switches

Type PAP1 limit switches are designed for work in control, monitoring and measurement circuits, e.g. in machine tools and technological equipment in the food industry, in packaging machines etc. The body is made of high quality plastic and the precise workmanship ensures good water tightness. The operating heads are exchangeable and may be installed in one of four possible positions. The operating heads enable efficient switching of the snap and slow action contact blocks.

The switches feature:

- safety symbol certificate 
- Office of Technical Inspection (UDT) type testing allowing their use in control and signalling systems for cranes and lifts
- product type approval certification allowing the use on ships granted by Polish Register of Shipping (PRS).

Technical drawings of limit switches in ".dwg" format are available at www.pokoj.com.pl in the section Offer, Design materials.

DIMENSIONS

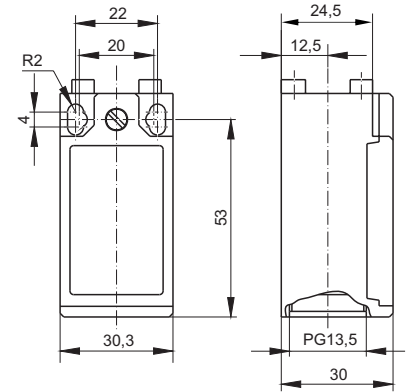













Technical data

TYPE	PAP1
Standards	IEC 60947-5-1, EN 60947-5-1, EN 50047
Rated switching voltage U _e	AC: 24/120/240/400V 50/60Hz DC: 24/125/250V
Rated switching currents I _e	AC: 10/6/3/1,8A DC: 2,8/0,55/0,27A
Use categories	AC-15, DC-13
Insulation rated voltage U _i (IEC 60947-1)	500V
Nominal impulse withstand voltage U _{imp}	A600, Q600
Protection degree (IEC 60529)	6kV
Environment pollution degree per IEC 60947-1	IP65
Short-circuiting protection (type and max. values for rated data of the protective device) U _e <500V a.c. Bi-Wts	3
Rated conventional air thermal current I _{th} (IEC 60947-5-1) 0<40°C	10A
Mechanical durability	10A
Electric shock protection (IEC 60536)	T11, T31+T32: 15×10 ⁶ cycles T13, T41+T72: 10×10 ⁶ cycles T91, T92, T98: > 5×10 ⁶ cycles
Ambient temperature	Class II
Max. switching cycles frequency	-25...+70 °C
Terminal resistance	3600 cycles/h
Terminal cross-section	25mΩ
Installation position	1 or 2 x 0,75+2,5mm ²
Casing material	any
	plastic

Accessories

Cat. no.	Type	Page
59-053□	Gland PG 13,5	219

PAP1 limit switches – T11 head steel plunger

Cat. no.	Type	Operating diagram	Connection diagram	Description
37-1020	PAP1T11PZ11 		Zb  (1NO+1NC)	snap action
37-1021	PAP1T11PZ02 		Zb  (2NC)	snap action
37-1022	PAP1T11PX11 		Zb  (1NO+1NC)	slow action open before close
37-1023	PAP1T11PY11 		Zb  (1NO+1NC)	slow action close before open
37-1024	PAP1T11PW02 		Zb  (2NC)	slow action simultaneous
37-1025	PAP1T11PW20 		Zb  (2NO)	slow action simultaneous

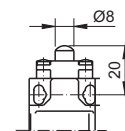

• - efficient opening points  efficient opening $v_{max}=0,5$ [m/s]; $F_{min}=15$ [N]; $F_{sk}=30$ [N] Zb - movable contacts are insulated

LIMIT SWITCHES

PAP1 limit switches – T13 head steel plunger with plastic roller Ø11

Cat. no.	Type	Operating diagram	Connection diagram	Description
37-1030	PAP1T13PZ11 ⊕		Zb (1NO+1NC)	snap action
37-1031	PAP1T13PZ02 ⊕		Zb (2NC)	snap action
37-1032	PAP1T13PX11 ⊕		Zb (1NO+1NC)	slow action open before close
37-1033	PAP1T13PY11 ⊕		Zb (1NO+1NC)	slow action close before open
37-1034	PAP1T13PW02 ⊕		Zb (2NC)	slow action simultaneous
37-1035	PAP1T13PW20		Zb (2NO)	slow action simultaneous

• - efficient opening points ⊕ efficient opening $v_{max}=0,5$ [m/s]; $F_{min}=15$ [N]; $F_{sk}=30$ [N] Zb - movable contacts are insulated



PAP1 limit switches – T31 head steel plunger and steel roller lever Ø12.5

Cat. no.	Type	Operating diagram	Connection diagram	Description
37-1050	PAP1T31PZ11 ⊕		Zb (1NO+1NC)	snap action
37-1051	PAP1T31PZ02 ⊕		Zb (2NC)	snap action
37-1052	PAP1T31PX11 ⊕		Zb (1NO+1NC)	slow action open before close
37-1053	PAP1T31PY11 ⊕		Zb (1NO+1NC)	slow action close before open
37-1054	PAP1T31PW02 ⊕		Zb (2NC)	slow action simultaneous
37-1055	PAP1T31PW20		Zb (2NO)	slow action simultaneous

• - efficient opening points ⊕ efficient opening $v_{max}=1,0$ [m/s]; $F_{min}=7$ [N]; $F_{sk}=24$ [N] Zb - movable contacts are insulated

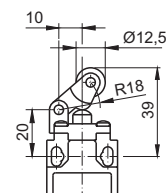

TYPE PAP1

PAP1 limit switches – T32 head steel plunger and vertical plastic roller lever Ø12.5

Cat. no.	Type	Operating diagram	Connection diagram	Description
37-1060	PAP1T32PZ11 ⊕		Zb (1NO+1NC)	snap action
37-1061	PAP1T32PZ02 ⊕		Zb (2NC)	snap action
37-1062	PAP1T32PX11 ⊕		Zb (1NO+1NC)	slow action open before close
37-1063	PAP1T32PY11 ⊕		Zb (1NO+1NC)	slow action close before open
37-1064	PAP1T32PW02 ⊕		Zb (2NC)	slow action simultaneous
37-1065	PAP1T32PW20		Zb (2NO)	slow action simultaneous

• - efficient opening points ⊕ efficient opening $v_{max}=1,0$ [m/s]; $F_{min}=7$ [N]; $F_{sk}=24$ [N] Zb - movable contacts are insulated

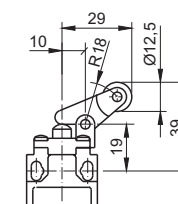

PAP1 limit switches – T41 head plastic roller lever Ø18

Cat. no.	Type	Operating diagram	Connection diagram	Description
37-1080	PAP1T41PZ11		Zb (1NO+1NC)	snap action
37-1081	PAP1T41PZ02		Zb (2NC)	snap action
37-1082	PAP1T41PX11		Zb (1NO+1NC)	slow action open before close
37-1083	PAP1T41PY11		Zb (1NO+1NC)	slow action close before open
37-1084	PAP1T41PW02		Zb (2NC)	slow action simultaneous
37-1085	PAP1T41PW20		Zb (2NO)	slow action simultaneous

• - efficient opening points ⊕ efficient opening $v_{max}=1,5$ [m/s]; $M_{min}=0,1$ [Nm]; $M_{sk}=0,32$ [Nm] Zb - movable contacts are insulated

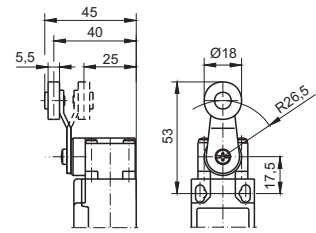

PAP1 limit switches – T42 head ubber roller lever Ø50

Cat. no.	Type	Operating diagram	Connection diagram	Description
37-1090	PAP1T42PZ11		Zb (1NO+1NC)	snap action
37-1091	PAP1T42PZ02		Zb (2NC)	snap action
37-1092	PAP1T42PX11		Zb (1NO+1NC)	slow action open before close
37-1093	PAP1T42PY11		Zb (1NO+1NC)	slow action close before open
37-1094	PAP1T42PW02		Zb (2NC)	slow action simultaneous
37-1095	PAP1T42PW20		Zb (2NO)	slow action simultaneous

• - efficient opening points ⊕ efficient opening $v_{max}=1,5$ [m/s]; $M_{min}=0,1$ [Nm]; $M_{sk}=0,32$ [Nm] Zb - movable contacts are insulated

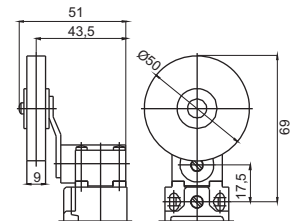

TYPE PAP1

PAP1 limit switches – T51 head adjustable plastic roller lever Ø18

Cat. no.	Type	Operating diagram	Connection diagram	Description
37-1110	PAP1T51PZ11		Zb (1NO+1NC)	snap action
37-1111	PAP1T51PZ02		Zb (2NC)	snap action
37-1112	PAP1T51PX11		Zb (1NO+1NC)	slow action open before close
37-1113	PAP1T51PY11		Zb (1NO+1NC)	slow action close before open
37-1114	PAP1T51PW02		Zb (2NC)	slow action simultaneous
37-1115	PAP1T51PW20		Zb (2NO)	slow action simultaneous

• - efficient opening points ⊕ efficient opening $v_{max}=1,5$ [m/s]; $M_{min}=0,1$ [Nm]; $M_{sk}=0,32$ [Nm] Zb - movable contacts are insulated

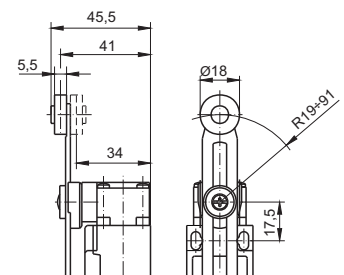

LIMIT SWITCHES

PAP1 limit switches – T52 head adjustable rubber roller lever Ø50

Cat. no.	Type	Operating diagram	Connection diagram	Description
37-1120	PAP1T52PZ11		Zb (1NO+1NC)	snap action
37-1121	PAP1T52PZ02		Zb (2NC)	snap action
37-1122	PAP1T52PX11		Zb (1NO+1NC)	slow action open before close
37-1123	PAP1T52PY11		Zb (1NO+1NC)	slow action close before open
37-1124	PAP1T52PW02		Zb (2NC)	slow action simultaneous
37-1125	PAP1T52PW20		Zb (2NO)	slow action simultaneous

• - efficient opening points ⊕ efficient opening $v_{max}=1,5$ [m/s]; $M_{min}=0,1$ [Nm]; $M_{sk}=0,32$ [Nm] Zb - movable contacts are insulated

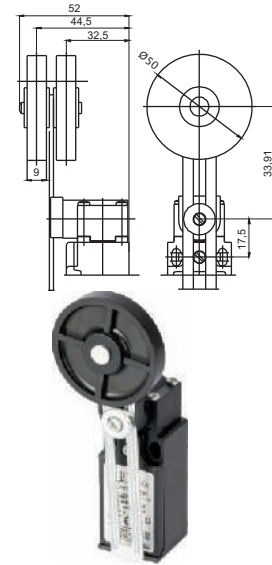

PAP1 limit switches – T61 head steel spring with plastic end

Cat. no.	Type	Operating diagram	Connection diagram	Description
37-1100	PAP1T61PZ11		Zb (1NO+1NC)	snap action
37-1101	PAP1T61PZ02		Zb (2NC)	snap action
37-1102	PAP1T61PX11		Zb (1NO+1NC)	slow action open before close
37-1103	PAP1T61PY11		Zb (1NO+1NC)	slow action close before open
37-1104	PAP1T61PW02		Zb (2NC)	slow action simultaneous
37-1105	PAP1T61PW20		Zb (2NO)	slow action simultaneous

$v_{max}=1,5$ [m/s]; $M_{min}=0,1$ [Nm] Zb - movable contacts are insulated

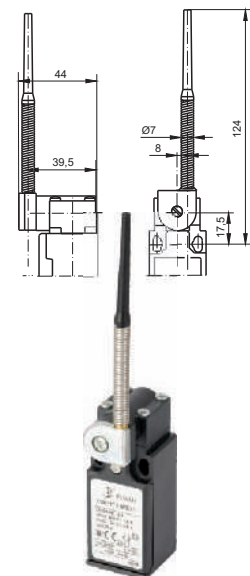

PAP1 limit switch – T71 head stainless steel rod Ø3

Cat. no.	Type	Operating diagram	Connection diagram	Description
37-1130	PAP1T71PZ11		Zb (1NO+1NC)	snap action
37-1131	PAP1T71PZ02		Zb (2NC)	snap action
37-1132	PAP1T71PX11		Zb (1NO+1NC)	slow action open before close
37-1133	PAP1T71PY11		Zb (1NO+1NC)	slow action close before open
37-1134	PAP1T71PW02		Zb (2NC)	slow action simultaneous
37-1135	PAP1T71PW20		Zb (2NO)	slow action simultaneous

• - efficient opening points ⊕ efficient opening $v_{max}=1,5$ [m/s]; $M_{min}=0,1$ [Nm]; $M_{sk}=0,32$ [Nm] Zb - movable contacts are insulated

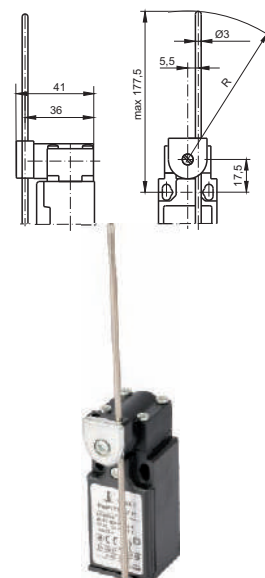

PAP1 limit switches – T72 head fibreglass rod Ø3

Cat. no.	Type	Operating diagram	Connection diagram	Description
37-1140	PAP1T72PZ11		Zb	(1NO+1NC) snap action
37-1141	PAP1T72PZ02		Zb	(2NC) snap action
37-1142	PAP1T72PX11		Zb	(1NO+1NC) slow action open before close
37-1143	PAP1T72PY11		Zb	(1NO+1NC) slow action close before open
37-1144	PAP1T72PW02		Zb	(2NC) slow action simultaneous
37-1145	PAP1T72PW20		Zb	(2NO) slow action simultaneous

• - efficient opening points ⊕ efficient opening $v_{max}=1,5$ [m/s]; $M_{min}=0,1$ [Nm]; $M_{sk}=0,32$ [Nm] Zb - movable contacts are insulated

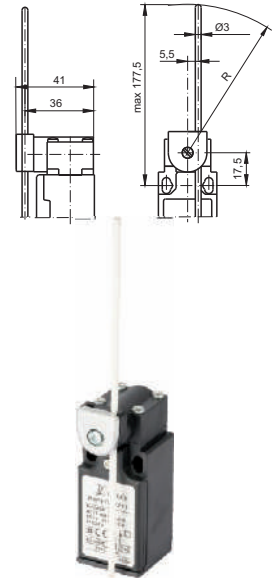

PAP1 limit switches – T91 head stainless steel multidirectional action spring

Cat. no.	Type	Operating diagram	Connection diagram	Description
37-1150	PAP1T91PZ11		Zb	(1NO+1NC) snap action
37-1151	PAP1T91PZ02		Zb	(2NC) snap action
37-1152	PAP1T91PX11		Zb	(1NO+1NC) slow action open before close
37-1153	PAP1T91PY11		Zb	(1NO+1NC) slow action close before open
37-1154	PAP1T91PW02		Zb	(2NC) slow action simultaneous
37-1155	PAP1T91PW20		Zb	(2NO) slow action simultaneous

$v_{max}=1,0$ [m/s]; $M_{min}=0,12$ [Nm] Zb - movable contacts are insulated

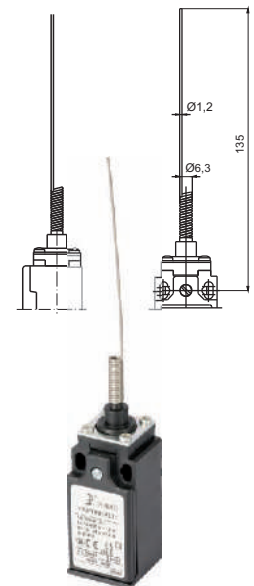

PAP1 limit switches – T92 head stainless steel spring with plastic end, multidirectional action

Cat. no.	Type	Operating diagram	Connection diagram	Description
37-1160	PAP1T92PZ11		Zb	(1NO+1NC) snap action
37-1161	PAP1T92PZ02		Zb	(2NC) snap action
37-1162	PAP1T92PX11		Zb	(1NO+1NC) slow action open before close
37-1163	PAP1T92PY11		Zb	(1NO+1NC) slow action close before open
37-1164	PAP1T92PW02		Zb	(2NC) slow action simultaneous
37-1165	PAP1T92PW20		Zb	(2NO) slow action simultaneous

$v_{max}=1,0$ [m/s]; $M_{min}=0,12$ [Nm] Zb - movable contacts are insulated

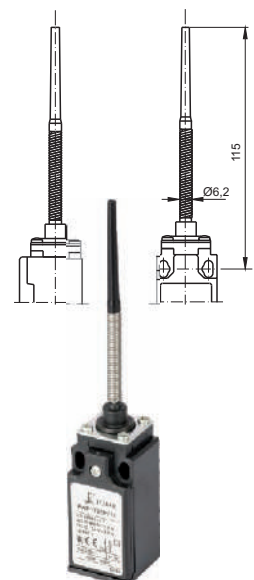

LIMIT SWITCHES

PAP1 limit switches – T98 head ring pull action

Cat. no.	Type	Operating diagram	Connection diagram	Description
37-1980	PAP1T98PZ11A		Zb	snap action
37-1982	PAP1T98PX11A		Zb	slow action open before close
37-1983	PAP1T98PY11A		Zb	slow action close before open
37-1984	PAP1T98PW02A		Zb	slow action simultaneous
37-1985	PAP1T98PW20A		Zb	slow action simultaneous

$v_{max}=0,5$ [m/s]; $F_{min}=30$ [N] Zb - movable contacts are insulated



PAP1 limit switches – R11 head steel plunger with reset function

Cat. no.	Type	Connection diagram	Description
37-1R10	PAP1R11PZ11 ⊕	Zb	snap action
37-1R11	PAP1R11PZ02 ⊕	Zb	snap action
37-1R12	PAP1R11PX11 ⊕	Zb	slow action open before close
37-1R14	PAP1R11PW02 ⊕	Zb	slow action simultaneous

⊕ efficient opening Zb - movable contacts are insulated



PAP1 limit switches – R13 head steel plunger with plastic roller Ø10.5, with reset function

Cat. no.	Type	Connection diagram	Description
37-1R20	PAP1R13PZ11 ⊕	Zb	snap action
37-1R21	PAP1R13PZ02 ⊕	Zb	snap action
37-1R22	PAP1R13PX11 ⊕	Zb	slow action open before close
37-1R24	PAP1R13PW02 ⊕	Zb	slow action simultaneous

⊕ efficient opening Zb - movable contacts are insulated







PAP1 limit switches – R31 head steel plunger and horizontal plastic roller lever Ø12.5, with reset function

Cat. no.	Type	Connection diagram	Description
37-1R30	PAP1R31PZ11 ⊕	Zb	snap action
37-1R31	PAP1R31PZ02 ⊕	Zb	snap action
37-1R32	PAP1R31PX11 ⊕	Zb	slow action open before close
37-1R34	PAP1R31PW02 ⊕	Zb	slow action simultaneous

⊕ efficient opening Zb - movable contacts are insulated







PAP1 limit switches – R32 head steel plunger and vertical plastic roller lever Ø12.5, with reset function

Cat. no.	Type	Connection diagram	Description
37-1R40	PAP1R32PZ11 ⊕	Zb  (1NO+1NC)	snap action
37-1R41	PAP1R32PZ02 ⊕	Zb  (2NC)	snap action
37-1R42	PAP1R32PX11 ⊕	Zb  (1NO+1NC)	slow action open before close
37-1R44	PAP1R32PW02 ⊕	Zb  (2NC)	slow action simultaneous

⊕ efficient opening Zb - movable contacts are insulated



PAP1 limit switches – R41 head plastic roller lever Ø18, with reset function

Cat. no.	Type	Connection diagram	Description
37-1R60	PAP1R41PZ11 ⊕	Zb  (1NO+1NC)	snap action
37-1R61	PAP1R41PZ02 ⊕	Zb  (2NC)	snap action
37-1R62	PAP1R41PX11 ⊕	Zb  (1NO+1NC)	slow action open before close
37-1R64	PAP1R41PW02 ⊕	Zb  (2NC)	slow action simultaneous

⊕ efficient opening Zb - movable contacts are insulated

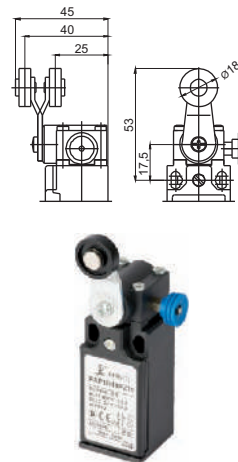

LIMIT SWITCHES

PSP1 type limit switches

Type PSP1 emergency stop limit switches for use in control, monitoring and measurement circuits. They can be installed on tangent balance, sliding, and removable machine covers. Opening of the machine cover turns off the power. The limit switch design prevents uncontrolled switching of contacts using simple tools. The casing is made of red and black plastic and the precise workmanship ensures good tightness. The operating heads can be installed in one of four possible positions (K1...) in continuous 360 degree range (K8...). They enable efficient switching of the snap and slow action contact blocks.

Depending on the use, the emergency limit switches are divided into three groups:

- with key - opening the machine cover pulls out the key from the socket and switches over the contacts. Wide range of keys allows the use of the connectors for all possible applications ,
- with lever or shaft to monitor small covers or big tangent balance doors. Installed in the rotation axis, directly to the movable element (switch with lever) or to hinge (switch with roller).
- with cord for use in machines and on production lines where it is impossible to install covers. They can be switched from any location along the cord run. A machine is switched off after pulling the cord and when the cord is broken.

Certificates:

- safety symbol certificate 
- Office of Technical Inspection (UDT) type testing allowing their use in control and signalling systems for cranes and lifts.
- product type approval certification allowing the use on ships granted by Polish Register of Shipping (PRS).

Technical drawings of limit switches in ".dwg" format are available at www.pokoj.com.pl in the section Offer, Design materials.

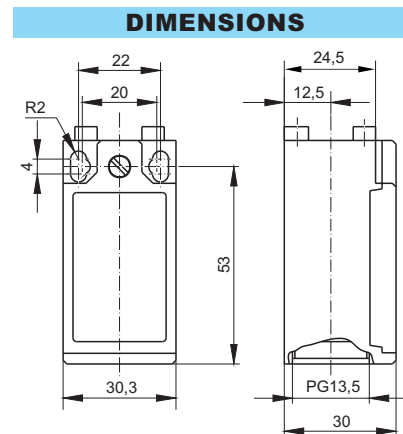

Technical data





TYPE	PSP1
Standards	IEC 60947-5-1, EN 60947-5-1, EN 50047
Rated switching voltage U_e	AC: 24/120/240/400V 50/60Hz DC: 24/125/250V
Rated switching currents I_e	AC: 10/6/3/1,8A DC: 2,8/0,55/0,27A
Use categories	AC-15, DC-13
Insulation rated voltage U_i (IEC 60947-1)	690V
Nominal impulse withstand voltage U_{imp}	A600, Q600
Protection degree (IEC 60529)	IP65
Environment pollution degree per IEC 60947-1	3
Short-circuiting protection (type and max. values for rated data of the protective device) $U_e < 500V$ a.c. Bi-Wts	10A
Rated conventional air thermal current I_{th} (IEC 60947-5-1) $0 < 40^\circ C$	10A
Electric shock protection (IEC 60536)	Class II
Ambient temperature	-25...+70 °C
Max. switching cycles frequency	3600 cycles/h
Terminal resistance	25mΩ
Terminal cross-section	1 or 2 x 0,75±2,5mm ²
Installation position	any
Casing material	plastic

Accessories

Cat. no.	Type	Page
59-053□	Gland PG 13,5	219

Connection diagrams for limit switches with key describes zero position of contacts (key is plugged in).



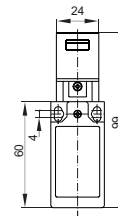

PSP1 limit switches – K83 head Head with bent narrow key no. 3, continuous 360° turn

Cat. no.	Type	Connection diagram	Description
37-2180	PSP1K83PZ11 ⊕	Zb  (1NO+1NC)	snap action
37-2181	PSP1K83PZ02 ⊕	Zb  (2NC)	snap action
37-2182	PSP1K83PX11 ⊕	Zb  (1NO+1NC)	slow action open before close
37-2183	PSP1K83PY11 ⊕	Zb  (1NO+1NC)	slow action close before open
37-2184	PSP1K83PW02 ⊕	Zb  (2NC)	slow action simultaneous

⊕ efficient opening Zb - movable contacts are insulated





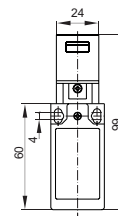

PSP1 limit switches – K84 head head with flat narrow key no. 4, continuous 360° turn

Cat. no.	Type	Connection diagram	Description
37-2190	PSP1K84PZ11 ⊕	Zb  (1NO+1NC)	snap action
37-2191	PSP1K84PZ02 ⊕	Zb  (2NC)	snap action
37-2192	PSP1K84PX11 ⊕	Zb  (1NO+1NC)	slow action open before close
37-2193	PSP1K84PY11 ⊕	Zb  (1NO+1NC)	slow action close before open
37-2194	PSP1K84PW02 ⊕	Zb  (2NC)	slow action simultaneous

⊕ efficient opening Zb - movable contacts are insulated



PSP1 limit switches – K85 head head with bent wide key no. 5, continuous 360° turn



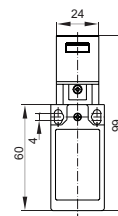

Cat. no.	Type	Connection diagram	Description
37-2210	PSP1K85PZ11 ⊕	Zb  (1NO+1NC)	snap action
37-2211	PSP1K85PZ02 ⊕	Zb  (2NC)	snap action
37-2212	PSP1K85PX11 ⊕	Zb  (1NO+1NC)	slow action open before close
37-2213	PSP1K85PY11 ⊕	Zb  (1NO+1NC)	slow action close before open
37-2214	PSP1K85PW02 ⊕	Zb  (2NC)	slow action simultaneous

⊕ efficient opening Zb - movable contacts are insulated



LIMIT SWITCHES



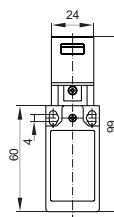

PSP1 limit switches – K86 head head with flat wide key no. 6, continuous 360° turn

Cat. no.	Type	Connection diagram	Description
37-2220	PSP1K86PZ11 ⊕	Zb  (1NO+1NC)	snap action
37-2221	PSP1K86PZ02 ⊕	Zb  (2NC)	snap action
37-2222	PSP1K86PX11 ⊕	Zb  (1NO+1NC)	slow action open before close
37-2223	PSP1K86PY11 ⊕	Zb  (1NO+1NC)	slow action close before open
37-2224	PSP1K86PW02 ⊕	Zb  (2NC)	slow action simultaneous

⊕ efficient opening Zb - movable contacts are insulated





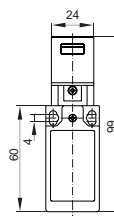

PSP1 limit switches – K87 head head with bent shock-absorbing key no. 7, continuous 360° turn

Cat. no.	Type	Connection diagram	Description
37-2230	PSP1K87PZ11 ⊕	Zb  (1NO+1NC)	snap action
37-2231	PSP1K87PZ02 ⊕	Zb  (2NC)	snap action
37-2232	PSP1K87PX11 ⊕	Zb  (1NO+1NC)	slow action open before close
37-2233	PSP1K87PY11 ⊕	Zb  (1NO+1NC)	slow action close before open
37-2234	PSP1K87PW02 ⊕	Zb  (2NC)	slow action simultaneous

⊕ efficient opening Zb - movable contacts are insulated





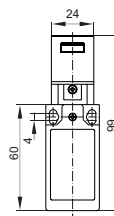

PSP1 limit switches – K88 head head with flat shock-absorbing key no. 8, continuous 360° turn

Cat. no.	Type	Connection diagram	Description
37-2240	PSP1K88PZ11 ⊕	Zb  (1NO+1NC)	snap action
37-2241	PSP1K88PZ02 ⊕	Zb  (2NC)	snap action
37-2242	PSP1K88PX11 ⊕	Zb  (1NO+1NC)	slow action open before close
37-2243	PSP1K88PY11 ⊕	Zb  (1NO+1NC)	slow action close before open
37-2244	PSP1K88PW02 ⊕	Zb  (2NC)	slow action simultaneous

⊕ efficient opening Zb - movable contacts are insulated







PSP1 limit switches – K89 head head with adjustable key no. 9, continuous 360° turn

Cat. no.	Type	Connection diagram	Description
37-2250	PSP1K89PZ11 ⊕	Zb  (1NO+1NC)	snap action
37-2251	PSP1K89PZ02 ⊕	Zb  (2NC)	snap action
37-2252	PSP1K89PX11 ⊕	Zb  (1NO+1NC)	slow action open before close
37-2253	PSP1K89PY11 ⊕	Zb  (1NO+1NC)	slow action close before open
37-2254	PSP1K89PW02 ⊕	Zb  (2NC)	slow action simultaneous

⊕ efficient opening Zb - movable contacts are insulated





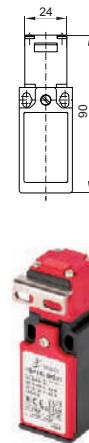

PSP1 limit switches – K13 head head with bent narrow key no. 3, 90° adjustable

Cat. no.	Type	Connection diagram	Description
37-2270	PSP1K13PZ11 ⊕	Zb  (1NO+1NC)	snap action
37-2271	PSP1K13PZ02 ⊕	Zb  (2NC)	snap action
37-2272	PSP1K13PX11 ⊕	Zb  (1NO+1NC)	slow action open before close
37-2273	PSP1K13PY11 ⊕	Zb  (1NO+1NC)	slow action close before open
37-2274	PSP1K13PW02 ⊕	Zb  (2NC)	slow action simultaneous

⊕ efficient opening Zb - movable contacts are insulated



PSP1 limit switches – K14 head head with flat narrow key no. 4, 90° adjustable



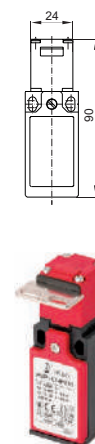

Cat. no.	Type	Connection diagram	Description
37-2280	PSP1K14PZ11 ⊕	Zb  (1NO+1NC)	snap action
37-2281	PSP1K14PZ02 ⊕	Zb  (2NC)	snap action
37-2282	PSP1K14PX11 ⊕	Zb  (1NO+1NC)	slow action open before close
37-2283	PSP1K14PY11 ⊕	Zb  (1NO+1NC)	slow action close before open
37-2284	PSP1K14PW02 ⊕	Zb  (2NC)	slow action simultaneous

⊕ efficient opening Zb - movable contacts are insulated



LIMIT SWITCHES



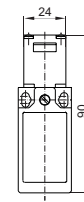

PSP1 limit switches – K15 head head with bent wide key no. 5, 90° adjustable

Cat. no.	Type	Connection diagram	Description
37-2290	PSP1K15PZ11 ⊕	Zb  (1NO+1NC)	snap action
37-2291	PSP1K15PZ02 ⊕	Zb  (2NC)	snap action
37-2292	PSP1K15PX11 ⊕	Zb  (1NO+1NC)	slow action open before close
37-2293	PSP1K15PY11 ⊕	Zb  (1NO+1NC)	slow action close before open
37-2294	PSP1K15PW02 ⊕	Zb  (2NC)	slow action simultaneous

⊕ efficient opening Zb - movable contacts are insulated





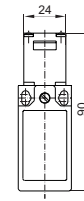

PSP1 limit switches – K16 head head with flat wide key no. 6, 90° adjustable

Cat. no.	Type	Connection diagram	Description
37-2300	PSP1K16PZ11 ⊕	Zb  (1NO+1NC)	snap action
37-2301	PSP1K16PZ02 ⊕	Zb  (2NC)	snap action
37-2302	PSP1K16PX11 ⊕	Zb  (1NO+1NC)	slow action open before close
37-2303	PSP1K16PY11 ⊕	Zb  (1NO+1NC)	slow action close before open
37-2304	PSP1K16PW02 ⊕	Zb  (2NC)	slow action simultaneous

⊕ efficient opening Zb - movable contacts are insulated





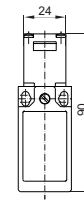

PSP1 limit switches – K17 head head with bent shock absorbing key no. 7, 90° adjustable

Cat. no.	Type	Connection diagram	Description
37-2310	PSP1K17PZ11 ⊕	Zb  (1NO+1NC)	snap action
37-2311	PSP1K17PZ02 ⊕	Zb  (2NC)	snap action
37-2312	PSP1K17PX11 ⊕	Zb  (1NO+1NC)	slow action open before close
37-2313	PSP1K17PY11 ⊕	Zb  (1NO+1NC)	slow action close before open
37-2314	PSP1K17PW02 ⊕	Zb  (2NC)	slow action simultaneous

⊕ efficient opening Zb - movable contacts are insulated





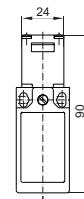

PSP1 limit switches – K18 head head with flat shock absorbing key no. 8, 90° adjustable

Cat. no.	Type	Connection diagram	Description
37-2320	PSP1K18PZ11 ⊕	Zb  (1NO+1NC)	snap action
37-2321	PSP1K18PZ02 ⊕	Zb  (2NC)	snap action
37-2322	PSP1K18PX11 ⊕	Zb  (1NO+1NC)	slow action open before close
37-2323	PSP1K18PY11 ⊕	Zb  (1NO+1NC)	slow action close before open
37-2324	PSP1K18PW02 ⊕	Zb  (2NC)	slow action simultaneous

⊕ efficient opening Zb - movable contacts are insulated



PSP1 limit switches – K19 head head with adjustable key no. 9, 90° adjustable

Cat. no.	Type	Connection diagram	Description
37-2330	PSP1K19PZ11 ⊕	Zb  (1NO+1NC)	snap action
37-2331	PSP1K19PZ02 ⊕	Zb  (2NC)	snap action
37-2332	PSP1K19PX11 ⊕	Zb  (1NO+1NC)	slow action open before close
37-2333	PSP1K19PY11 ⊕	Zb  (1NO+1NC)	slow action close before open
37-2334	PSP1K19PW02 ⊕	Zb  (2NC)	slow action simultaneous

⊕ efficient opening Zb - movable contacts are insulated

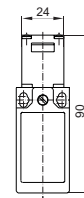

TYPE PSP1

Keys

Cat. no.	Type	Cat. no.	Type	Cat. no.	Type	Cat. no.	Type
37-8503	Key 3	37-8504	Key 4	37-8505	Key 5	37-8506	Key 6

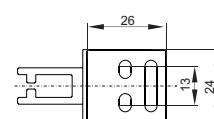
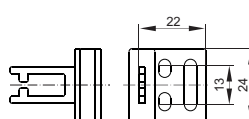
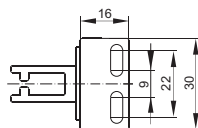
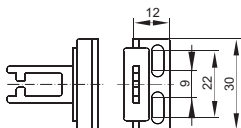

LIMIT SWITCHES

Cat. no.	Type	Cat. no.	Type	Cat. no.	Type
37-8507	Key 7	37-8508	Key 8	37-8509	Key 9

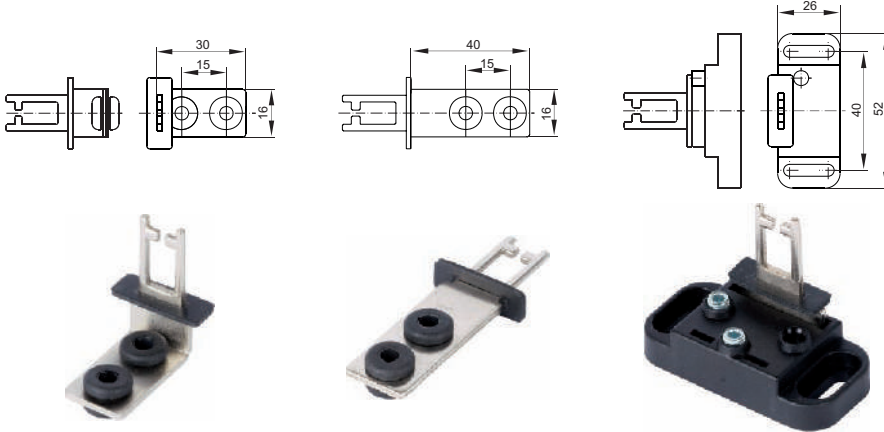

PSP1 limit switches – K61 head head with galvanized steel lever, 90° adjustable

Cat. no.	Type	Connection diagram	Description
37-2360	PSP1K61PZ11 ⊕	Zb (1NO+1NC)	snap action
37-2361	PSP1K61PZ02 ⊕	Zb (2NC)	snap action
37-2362	PSP1K61PX11 ⊕	Zb (1NO+1NC)	slow action open before close
37-2363	PSP1K61PY11 ⊕	Zb (1NO+1NC)	slow action close before open
37-2364	PSP1K61PW02 ⊕	Zb (2NC)	slow action simultaneous

⊕ efficient opening Zb - movable contacts are insulated

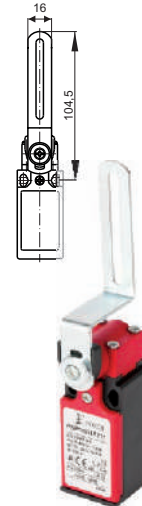

PSP1 limit switches – K71 head head with galvanized steel roller, 90° adjustable

Cat. no.	Type	Connection diagram	Description
37-2340	PSP1K71PZ11 ⊕	Zb (1NO+1NC)	snap action
37-2341	PSP1K71PZ02 ⊕	Zb (2NC)	snap action
37-2342	PSP1K71PX11 ⊕	Zb (1NO+1NC)	slow action open before close
37-2343	PSP1K71PY11 ⊕	Zb (1NO+1NC)	slow action close before open
37-2344	PSP1K71PW02 ⊕	Zb (2NC)	slow action simultaneous

⊕ efficient opening Zb - movable contacts are insulated

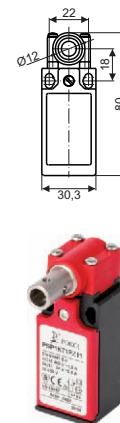

Contacts are switched on every 360°

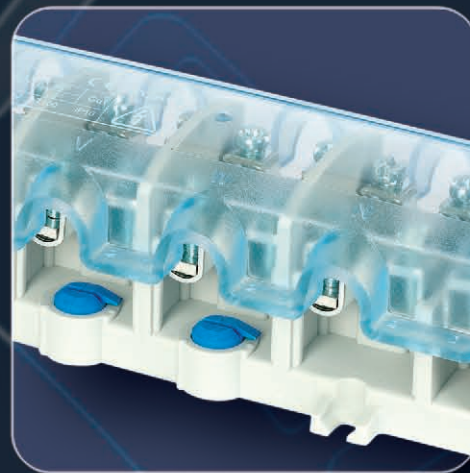

"POKÓJ" S. E.
ul. Warecka 1
91-202 Łódź
tel.: +48 42 254 79 00
fax: +48 42 254 79 09
e-mail:
market@pokojs.com.pl
www.pokojs.com.pl

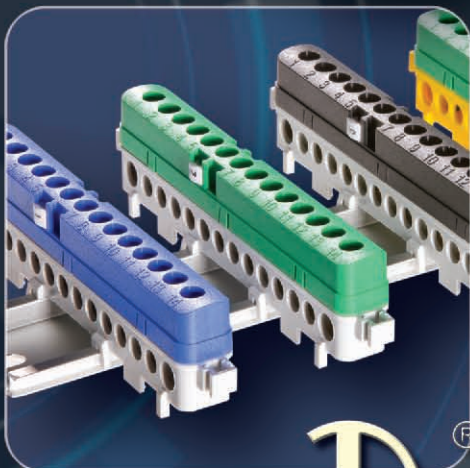

POKÓJ

Rok zał. 1951

LIMIT SWITCHES

PAM1 type limit switches

Type PAM1 limit switches are designed for work in control, monitoring and measurement circuits, e.g. in machine tools and technological equipment in the food industry, in packaging machines etc. The body is made of metal and the precise workmanship ensures good water tightness. The operating heads are exchangeable and may be installed in one of four possible positions. The operating heads enable efficient switching of the snap and slow action contact blocks.

The switches feature:

- safety symbol certificate 
- Office of Technical Inspection (UDT) type testing allowing their use in control and signalling systems for cranes and lifts
- product type approval certification allowing the use on ships granted by Polish Register of Shipping (PRS).

Technical drawings of limit switches in ".dwg" format are available at www.pokoj.com.pl in the section Offer, Design materials.

DIMENSIONS

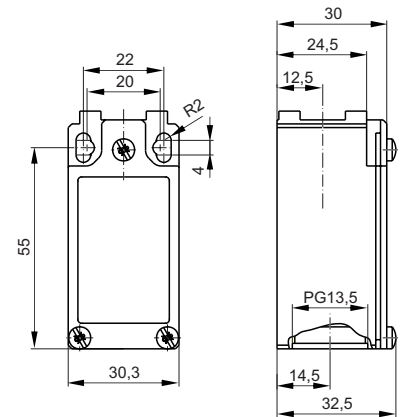







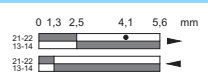
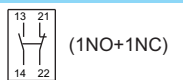

Technical data

TYPE	PAM1
Standards	IEC 60947-5-1, EN 60947-5-1, EN 50047
Rated switching voltage U _e	AC: 24/120/240V 50/60Hz DC: 24/125/250V
Rated switching currents I _e	AC: 10/6/3/1,8A DC: 2,8/0,55/0,27A
Use categories	AC-15, DC-13
Insulation rated voltage U _i (IEC 60947-1)	500V
Nominal impulse withstand voltage U _{imp}	A300, Q300
Protection degree (IEC 60529)	6kV
Environment pollution degree per IEC 60947-1	IP66, IP65 (for F52)
Short-circuiting protection (type and max. values for rated data of the protective device) U _e <500V a.c. Bi-Wts	3
Rated conventional air thermal current I _{th} (IEC 60947-5-1) 0<40°C	10A
Mechanical durability	10A
Electric shock protection (IEC 60536)	F11, F12: 15×10 ⁶ cycles F41, F42, F45: 10×10 ⁶ cycles F51, F52, F71: 10×10 ⁶ cycles
Ambient temperature	Class II
Max. switching cycles frequency	-25...+70 °C
Terminal resistance	3600 cycles/h
Terminal cross-section	25mΩ
Installation position	1 or 2 x 0,75+2,5mm ²
Casing material	any
	metal

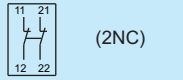
Accessories

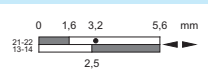
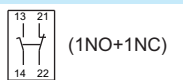
Cat. no.	Type	Page
59-053□	Gland PG 13,5	219

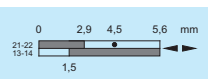
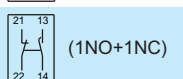
PAM limit switches – F11 head steel plunger

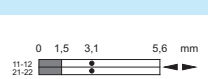
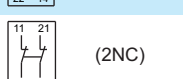
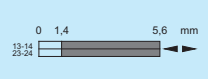
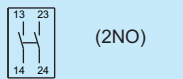
Cat. no.	Type	Operating diagram	Connection diagram	Description
37-4650	PAM1F11PZ11 		Zb  (1NO+1NC)	snap action
37-4651	PAM1F11PZ02 		Zb  (2NC)	snap action
37-4652	PAM1F11PX11 		Zb  (1NO+1NC)	slow action open before close
37-4653	PAM1F11PY11 		Zb  (1NO+1NC)	slow action close before open
37-4654	PAM1F11PW02 		Zb  (2NC)	slow action simultaneous
37-4655	PAM1F11PW20		Zb  (2NO)	slow action simultaneous

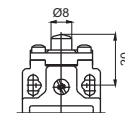

• - efficient opening points  efficient opening v_{max}=0,5 [m/s]; F_{min}=15 [N]; F_{sk}=30 [N] Zb - movable contacts are insulated

PAM1 limit switches – F12 head steel plunger with steel roller Ø10.5

Cat. no.	Type	Operating diagram	Connection diagram	Description
37-4660	PAM1F12PZ11		Zb	snap action
37-4661	PAM1F12PZ02		Zb	snap action
37-4662	PAM1F12PX11		Zb	slow action open before close
37-4663	PAM1F12PY11		Zb	slow action close before open
37-4664	PAM1F12PW02		Zb	slow action simultaneous
37-4665	PAM1F12PW20		Zb	slow action simultaneous

• - efficient opening points ⊕ efficient opening $v_{max}=0,5$ [m/s]; $F_{min}=15$ [N]; $F_{sk}=30$ [N] Zb - movable contacts are insulated

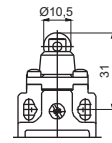

PAM1 limit switches – F41 head plastic roller lever Ø18

Cat. no.	Type	Operating diagram	Connection diagram	Description
37-4670	PAM1F41PZ11		Zb	snap action
37-4671	PAM1F41PZ02		Zb	snap action
37-4672	PAM1F41PX11		Zb	slow action open before close
37-4673	PAM1F41PY11		Zb	slow action close before open
37-4674	PAM1F41PW02		Zb	slow action simultaneous
37-4675	PAM1F41PW20		Zb	slow action simultaneous

• - efficient opening points ⊕ efficient opening $v_{max}=1,5$ [m/s]; $M_{min}=0,1$ [Nm]; $M_{sk}=0,32$ [Nm] Zb - movable contacts are insulated

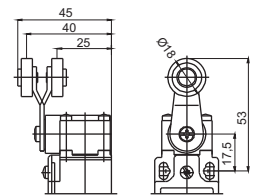

PAM1 limit switches – F42 head rubber roller lever Ø50

Cat. no.	Type	Operating diagram	Connection diagram	Description
37-4680	PAM1F42PZ11		Zb	snap action
37-4681	PAM1F42PZ02		Zb	snap action
37-4682	PAM1F42PX11		Zb	slow action open before close
37-4683	PAM1F42PY11		Zb	slow action close before open
37-4684	PAM1F42PW02		Zb	slow action simultaneous
37-4685	PAM1F42PW20		Zb	slow action simultaneous

• - efficient opening points ⊕ efficient opening $v_{max}=1,5$ [m/s]; $M_{min}=0,1$ [Nm]; $M_{sk}=0,32$ [Nm] Zb - movable contacts are insulated

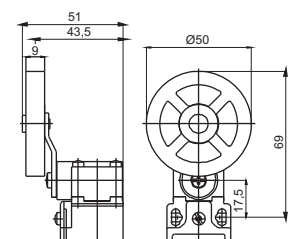

LIMIT SWITCHES

PAM1 limit switches – F45 head plastic roller lever Ø18

Cat. no.	Type	Operating diagram	Connection diagram	Description
37-4710	PAM1F45PZ11		Zb	snap action
37-4711	PAM1F45PZ02		Zb	snap action
37-4712	PAM1F45PX11		Zb	slow action open before close
37-4713	PAM1F45PY11		Zb	slow action close before open
37-4714	PAM1F45PW02		Zb	slow action simultaneous
37-4715	PAM1F45PW20		Zb	slow action simultaneous

• - efficient opening points ⊕ efficient opening $v_{max}=1,5$ [m/s]; $M_{min}=0,1$ [Nm]; $M_{sk}=0,32$ [Nm] Zb - movable contacts are insulated

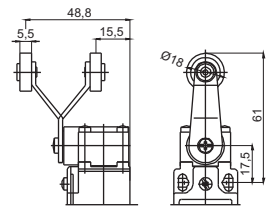

PAM1 limit switches – F51 head adjustable plastic roller lever Ø18

Cat. no.	Type	Operating diagram	Connection diagram	Description
37-4740	PAM1F51PZ11		Zb	snap action
37-4741	PAM1F51PZ02		Zb	snap action
37-4742	PAM1F51PX11		Zb	slow action open before close
37-4743	PAM1F51PY11		Zb	slow action close before open
37-4744	PAM1F51PW02		Zb	slow action simultaneous
37-4745	PAM1F51PW20		Zb	slow action simultaneous

• - efficient opening points ⊕ efficient opening $v_{max}=1,5$ [m/s]; $M_{min}=0,1$ [Nm]; $M_{sk}=0,32$ [Nm] Zb - movable contacts are insulated

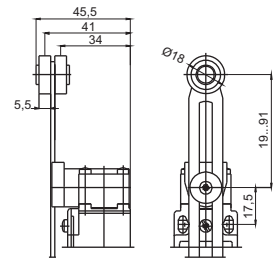

PAM1 limit switches – F52 head adjustable rubber roller lever Ø50

Cat. no.	Type	Operating diagram	Connection diagram	Description
37-4750	PAM1F52PZ11		Zb	snap action
37-4751	PAM1F52PZ02		Zb	snap action
37-4752	PAM1F52PX11		Zb	slow action open before close
37-4753	PAM1F52PY11		Zb	slow action close before open
37-4754	PAM1F52PW02		Zb	slow action simultaneous
37-4755	PAM1F52PW20		Zb	slow action simultaneous

• - efficient opening points ⊕ efficient opening $v_{max}=1,5$ [m/s]; $M_{min}=0,1$ [Nm]; $M_{sk}=0,32$ [Nm] Zb - movable contacts are insulated

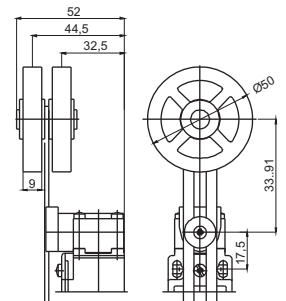

PAM1 limit switch – F71 head stainless steel rod Ø3

Cat. no.	Type	Operating diagram	Connection diagram	Description
37-4770	PAM1F71PZ11 ⊕		Zb (1NO+1NC)	snap action
37-4771	PAM1F71PZ02 ⊕		Zb (2NC)	snap action
37-4772	PAM1F71PX11 ⊕		Zb (1NO+1NC)	slow action open before close
37-4773	PAM1F71PY11 ⊕		Zb (1NO+1NC)	slow action close before open
37-4774	PAM1F71PW02 ⊕		Zb (2NC)	slow action simultaneous
37-4775	PAM1F71PW20		Zb (2NO)	slow action simultaneous

• - efficient opening points ⊕ efficient opening $v_{max}=1,5$ [m/s]; $M_{min}=0,1$ [Nm]; $M_{sk}=0,32$ [Nm] Zb - movable contacts are insulated

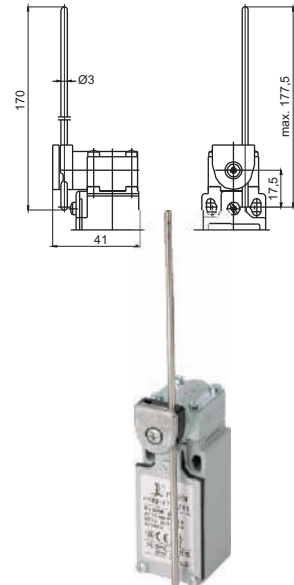

PAM1 limit switches – R11 head steel plunger with reset function

Cat. no.	Type	Connection diagram	Description
37-4R10	PAM1R11PZ11 ⊕	Zb (1NO+1NC)	snap action
37-4R11	PAM1R11PZ02 ⊕	Zb (2NC)	snap action
37-4R12	PAM1R11PX11 ⊕	Zb (1NO+1NC)	slow action open before close
37-4R14	PAM1R11PW02 ⊕	Zb (2NC)	slow action simultaneous

⊕ efficient opening Zb - movable contacts are insulated



PAM1 limit switches – R13 head steel plunger with plastic roller Ø10.5 and reset function

Cat. no.	Type	Connection diagram	Description
37-4R20	PAM1R13PZ11 ⊕	Zb (1NO+1NC)	snap action
37-4R21	PAM1R13PZ02 ⊕	Zb (2NC)	snap action
37-4R22	PAM1R13PX11 ⊕	Zb (1NO+1NC)	slow action open before close
37-4R24	PAM1R13PW02 ⊕	Zb (2NC)	slow action simultaneous

⊕ efficient opening Zb - movable contacts are insulated



LIMIT SWITCHES

PAM1 limit switches – R31 head steel plunger and horizontal plastic roller lever Ø12.5, with reset function

Cat. no.	Type	Connection diagram	Description
37-4R30	PAM1R31PZ11 ⊕	Zb (1NO+1NC)	snap action
37-4R31	PAM1R31PZ02 ⊕	Zb (2NC)	snap action
37-4R32	PAM1R31PX11 ⊕	Zb (1NO+1NC)	slow action open before close
37-4R34	PAM1R31PW02 ⊕	Zb (2NC)	slow action simultaneous

⊕ efficient opening Zb - movable contacts are insulated



PAM1 limit switches – R32 head steel plunger and vertical plastic roller lever Ø12.5, with reset function

Cat. no.	Type	Connection diagram	Description
37-4R40	PAM1R32PZ11 ⊕	Zb (1NO+1NC)	snap action
37-4R41	PAM1R32PZ02 ⊕	Zb (2NC)	snap action
37-4R42	PAM1R32PX11 ⊕	Zb (1NO+1NC)	slow action open before close
37-4R44	PAM1R32PW02 ⊕	Zb (2NC)	slow action simultaneous

⊕ efficient opening Zb - movable contacts are insulated

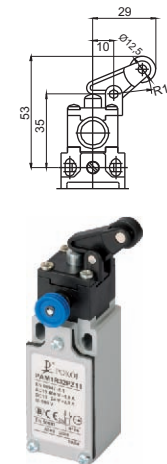

PAM1 limit switches – R41 head plastic roller lever Ø18 with reset function

Cat. no.	Type	Connection diagram	Description
37-4R60	PAM1R41PZ11 ⊕	Zb (1NO+1NC)	snap action
37-4R61	PAM1R41PZ02 ⊕	Zb (2NC)	snap action
37-4R62	PAM1R41PX11 ⊕	Zb (1NO+1NC)	slow action open before close
37-4R64	PAM1R41PW02 ⊕	Zb (2NC)	slow action simultaneous

⊕ efficient opening Zb - movable contacts are insulated

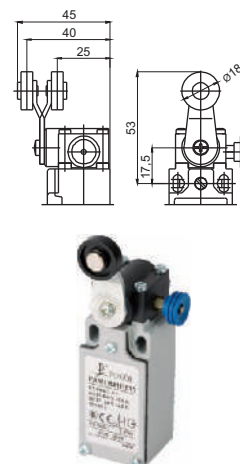

PBM1 type limit switches

Type PBM1 limit switches are designed for work in control, monitoring and measurement circuits, e.g. in machine tools and technological equipment in the food industry, in packaging machines etc. The body is made of metal and the precise workmanship ensures good water tightness. The operating heads are exchangeable and may be installed in one of four possible positions. The operating heads enable efficient switching of the snap and slow action contact blocks.

The switches feature:

- safety symbol certificate 
- Office of Technical Inspection (UDT) type testing allowing their use in control and signalling systems for cranes and lifts
- product type approval certification allowing the use on ships granted by Polish Register of Shipping (PRS).

Technical drawings of limit switches in ".dwg" format are available at www.pokoj.com.pl in the section Offer, Design materials.

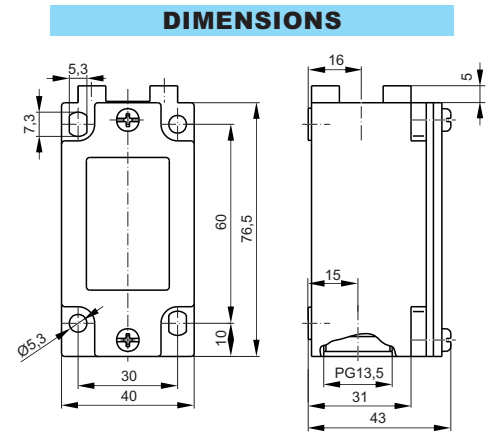

Technical data

TYPE	PBM1
Standards	IEC 60947-5-1, EN 60947-5-1, EN 50047
Rated switching voltage U_e	AC: 24/120/240V 50/60Hz DC: 24/125/250V
Rated switching currents I_e	AC: 10/6/3/1,8A DC: 2,8/0,55/0,27A
Use categories	AC-15, DC-13
Insulation rated voltage U_i (IEC 60947-1)	500V
Nominal impulse withstand voltage U_{imp}	A300, Q300
Protection degree (IEC 60529)	6kV
Environment pollution degree per IEC 60947-1	IP66, IP65 (for E54, E92, E93)
Short-circuiting protection (type and max. values for rated data of the protective device) $U_e < 500V$ a.c. Bi-Wts	3
Rated conventional air thermal current I_{th} (IEC 60947-5-1) $0 < 40^\circ C$	10A
Mechanical durability	10A
Electric shock protection (IEC 60536)	E11+E32: 30×10^6 cycles E41+E72: 25×10^6 cycles E91+E99: 10×10^6 cycles
Ambient temperature	Class II
Max. switching cycles frequency	-25...+70 °C
Terminal resistance	3600 cycles/h
Terminal cross-section	25mΩ
Installation position	1 or 2 x 0,75±2,5mm ²
Casing material	any
	metal

Accessories

Cat. no.	Type	Page
59-053□	Gland PG 13,5	219

LIMIT SWITCHES

PBM1 limit switches – E11 head steel plunger

Cat. no.	Type	Operating diagram	Connection diagram	Description
37-3370	PBM1E11PZ11 ⊕		Zb	snap action
37-3371	PBM1E11PZ02 ⊕		Zb	snap action
37-3372	PBM1E11PX11 ⊕		Zb	slow action open before close
37-3373	PBM1E11PY11 ⊕		Zb	slow action close before open
37-3374	PBM1E11PW02 ⊕		Zb	slow action simultaneous
37-3375	PBM1E11PW20		Zb	slow action simultaneous
37-3376	PBM1E11PX21 ⊕		Zb	slow action close before open
37-3377	PBM1E11PX12 ⊕		Zb	slow action open before close
37-3378	PBM1E11PW03 ⊕		Zb	slow action simultaneous
37-3379	PBM1E11PW30		Zb	slow action simultaneous

• - efficient opening points ⊕ efficient opening $v_{max}=0,5$ [m/s]; $F_{min}=30$ [N]; $F_{sk}=45$ [N] Zb - movable contacts are insulated

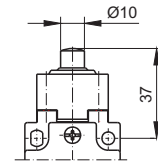

PBM1 limit switches – E12 head steel plunger with ball tip

Cat. no.	Type	Operating diagram	Connection diagram	Description
37-3390	PBM1E12PZ11 ⊕		Zb	snap action
37-3391	PBM1E12PZ02 ⊕		Zb	snap action
37-3392	PBM1E12PX11 ⊕		Zb	slow action open before close
37-3393	PBM1E12PY11 ⊕		Zb	slow action close before open
37-3394	PBM1E12PW02 ⊕		Zb	slow action simultaneous
37-3395	PBM1E12PW20		Zb	slow action simultaneous
37-3396	PBM1E12PX21 ⊕		Zb	slow action close before open
37-3397	PBM1E12PX12 ⊕		Zb	slow action open before close
37-3398	PBM1E12PW03 ⊕		Zb	slow action simultaneous
37-3399	PBM1E12PW30		Zb	slow action simultaneous

• - efficient opening points ⊕ efficient opening $v_{max}=0,5$ [m/s]; $F_{min}=15$ [N]; $F_{sk}=30$ [N] Zb - movable contacts are insulated

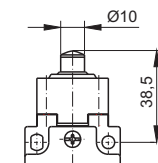

PBM1 limit switches – E13 head steel plunger with steel roller Ø12

Cat. no.	Type	Operating diagram	Connection diagram	Description
37-3400	PBM1E13PZ11		Zb	snap action
37-3401	PBM1E13PZ02		Zb	snap action
37-3402	PBM1E13PX11		Zb	slow action open before close
37-3403	PBM1E13PY11		Zb	slow action close before open
37-3404	PBM1E13PW02		Zb	slow action simultaneous
37-3405	PBM1E13PW20		Zb	slow action simultaneous
37-3406	PBM1E13PX21		Zb	slow action close before open
37-3407	PBM1E13PX12		Zb	slow action open before close
37-3408	PBM1E13PW03		Zb	slow action simultaneous
37-3409	PBM1E13PW30		Zb	slow action simultaneous

• - efficient opening points ⊕ efficient opening $v_{max}=0,5$ [m/s]; $F_{min}=22$ [N]; $F_{sk}=40$ [N] Zb - movable contacts are insulated

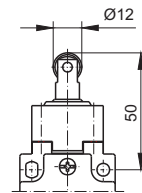

PBM1 limit switches – E21 head side steel plunger

Cat. no.	Type	Operating diagram	Connection diagram	Description
37-3420	PBM1E21PZ11		Zb	snap action
37-3421	PBM1E21PZ02		Zb	snap action
37-3422	PBM1E21PX11		Zb	slow action open before close
37-3423	PBM1E21PY11		Zb	slow action close before open
37-3424	PBM1E21PW02		Zb	slow action simultaneous
37-3425	PBM1E21PW20		Zb	slow action simultaneous
37-3426	PBM1E21PX21		Zb	slow action close before open
37-3427	PBM1E21PX12		Zb	slow action open before close
37-3428	PBM1E21PW03		Zb	slow action simultaneous
37-3429	PBM1E21PW30		Zb	slow action simultaneous

• - efficient opening points ⊕ efficient opening $v_{max}=0,5$ [m/s]; $F_{min}=30$ [N]; $F_{sk}=50$ [N] Zb - movable contacts are insulated

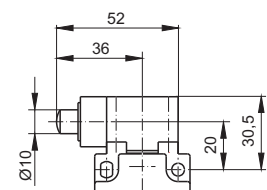

LIMIT SWITCHES

PBM1 limit switches – E22 head side steel plunger with vertical steel roller Ø12

Cat. no.	Type	Operating diagram	Connection diagram	Description
37-3430	PBM1E22PZ11		Zb (1NO+1NC)	snap action
37-3431	PBM1E22PZ02		Zb (2NC)	snap action
37-3432	PBM1E22PX11		Zb (1NO+1NC)	slow action open before close
37-3433	PBM1E22PY11		Zb (1NO+1NC)	slow action close before open
37-3434	PBM1E22PW02		Zb (2NC)	slow action simultaneous
37-3435	PBM1E22PW20		Zb (2NO)	slow action simultaneous
37-3436	PBM1E22PX21		Zb (1NC+2NO)	slow action close before open
37-3437	PBM1E22PX12		Zb (2NC+1NO)	slow action open before close
37-3438	PBM1E22PW03		Zb (3NC)	slow action simultaneous
37-3439	PBM1E22PW30		Zb (3NO)	slow action simultaneous

• - efficient opening points ⊕ efficient opening $v_{max}=0,5$ [m/s]; $F_{min}=30$ [N]; $F_{sk}=50$ [N] Zb - movable contacts are insulated

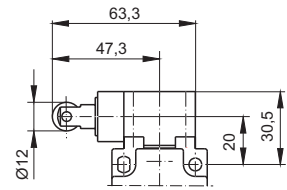

PBM1 limit switches – E23 head side steel plunger with horizontal steel roller Ø12

Cat. no.	Type	Operating diagram	Connection diagram	Description
37-3440	PBM1E23PZ11		Zb (1NO+1NC)	snap action
37-3441	PBM1E23PZ02		Zb (2NC)	snap action
37-3442	PBM1E23PX11		Zb (1NO+1NC)	slow action open before close
37-3443	PBM1E23PY11		Zb (1NO+1NC)	slow action close before open
37-3444	PBM1E23PW02		Zb (2NC)	slow action simultaneous
37-3445	PBM1E23PW20		Zb (2NO)	slow action simultaneous
37-3446	PBM1E23PX21		Zb (1NC+2NO)	slow action close before open
37-3447	PBM1E23PX12		Zb (2NC+1NO)	slow action open before close
37-3448	PBM1E23PW03		Zb (3NC)	slow action simultaneous
37-3449	PBM1E23PW30		Zb (3NO)	slow action simultaneous

• - efficient opening points ⊕ efficient opening $v_{max}=0,5$ [m/s]; $F_{min}=30$ [N]; $F_{sk}=50$ [N] Zb - movable contacts are insulated

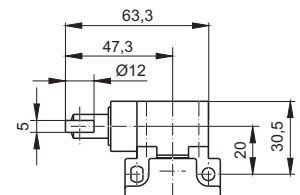

PBM1 limit switches – E32 head steel plunger and steel roller lever Ø22

Cat. no.	Type	Operating diagram	Connection diagram	Description
37-3460	PBM1E32PZ11		Zb	snap action
37-3461	PBM1E32PZ02		Zb	snap action
37-3462	PBM1E32PX11		Zb	slow action open before close
37-3463	PBM1E32PY11		Zb	slow action close before open
37-3464	PBM1E32PW02		Zb	slow action simultaneous
37-3465	PBM1E32PW20		Zb	slow action simultaneous
37-3466	PBM1E32PX21		Zb	slow action close before open
37-3467	PBM1E32PX12		Zb	slow action open before close
37-3468	PBM1E32PW03		Zb	slow action simultaneous
37-3469	PBM1E32PW30		Zb	slow action simultaneous

• - efficient opening points ⊕ efficient opening $v_{max}=1,5$ [m/s]; $F_{min}=12$ [N]; $F_{sk}=40$ [N] Zb - movable contacts are insulated

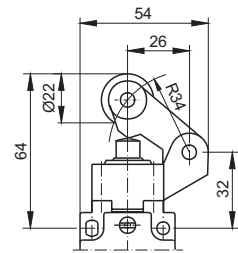

PBM1 limit switches – E41 head plastic roller lever Ø22

Cat. no.	Type	Operating diagram	Connection diagram	Description
37-3480	PBM1E41PZ11		Zb	snap action
37-3481	PBM1E41PZ02		Zb	snap action
37-3482	PBM1E41PX11		Zb	slow action open before close
37-3483	PBM1E41PY11		Zb	slow action close before open
37-3484	PBM1E41PW02		Zb	slow action simultaneous
37-3485	PBM1E41PW20		Zb	slow action simultaneous
37-3486	PBM1E41PX21		Zb	slow action close before open
37-3487	PBM1E41PX12		Zb	slow action open before close
37-3488	PBM1E41PW03		Zb	slow action simultaneous
37-3489	PBM1E41PW30		Zb	slow action simultaneous

• - efficient opening points ⊕ efficient opening $v_{max}=1,5$ [m/s]; $M_{min}=0,15$ [Nm]; $M_{sk}=0,30$ [Nm] Zb - movable contacts are insulated

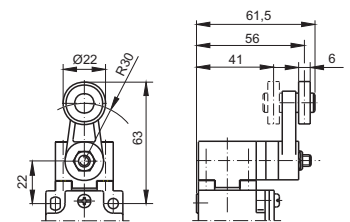

LIMIT SWITCHES

PBM1 limit switches – E42 head steel roller lever Ø22

Cat. no.	Type	Operating diagram	Connection diagram	Description
37-3490	PBM1E42PZ11 ⊕		Zb	(1NO+1NC) snap action
37-3491	PBM1E42PZ02 ⊕		Zb	(2NC) snap action
37-3492	PBM1E42PX11 ⊕		Zb	(1NO+1NC) slow action open before close
37-3493	PBM1E42PY11 ⊕		Zb	(1NO+1NC) slow action close before open
37-3494	PBM1E42PW02 ⊕		Zb	(2NC) slow action simultaneous
37-3495	PBM1E42PW20		Zb	(2NO) slow action simultaneous
37-3496	PBM1E42PX21 ⊕		Zb	(1NC+2NO) slow action close before open
37-3497	PBM1E42PX12 ⊕		Zb	(2NC+1NO) slow action open before close
37-3498	PBM1E42PW03 ⊕		Zb	(3NC) slow action simultaneous
37-3499	PBM1E42PW30		Zb	(3NO) slow action simultaneous

• - efficient opening points ⊕ efficient opening $v_{max}=1,5$ [m/s]; $M_{min}=0,15$ [Nm]; $M_{sk}=0,30$ [Nm] Zb - movable contacts are insulated

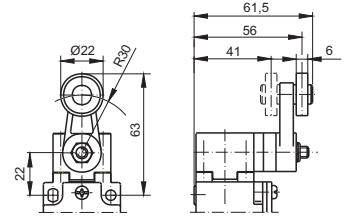

PBM1 limit switches – E44 head rubber roller lever Ø50

Cat. no.	Type	Operating diagram	Connection diagram	Description
37-3510	PBM1E44PZ11 ⊕		Zb	(1NO+1NC) snap action
37-3511	PBM1E44PZ02 ⊕		Zb	(2NC) snap action
37-3512	PBM1E44PX11 ⊕		Zb	(1NO+1NC) slow action open before close
37-3513	PBM1E44PY11 ⊕		Zb	(1NO+1NC) slow action close before open
37-3514	PBM1E44PW02 ⊕		Zb	(2NC) slow action simultaneous
37-3515	PBM1E44PW20		Zb	(2NO) slow action simultaneous
37-3516	PBM1E44PX21 ⊕		Zb	(1NC+2NO) slow action close before open
37-3517	PBM1E44PX12 ⊕		Zb	(2NC+1NO) slow action open before close
37-3518	PBM1E44PW03 ⊕		Zb	(3NC) slow action simultaneous
37-3519	PBM1E44PW30		Zb	(3NO) slow action simultaneous

• - efficient opening points ⊕ efficient opening $v_{max}=1,5$ [m/s]; $M_{min}=0,15$ [Nm]; $M_{sk}=0,30$ [Nm] Zb - movable contacts are insulated

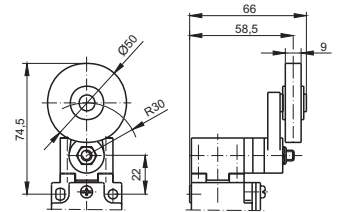

TYPE PBM1

PBM1 limit switches – E51 head adjustable plastic roller lever Ø22

Cat. no.	Type	Operating diagram	Connection diagram	Description
37-3520	PBM1E51PZ11 ⊕		Zb (1NO+1NC)	snap action
37-3521	PBM1E51PZ02 ⊕		Zb (2NC)	snap action
37-3522	PBM1E51PX11 ⊕		Zb (1NO+1NC)	slow action open before close
37-3523	PBM1E51PY11 ⊕		Zb (1NO+1NC)	slow action close before open
37-3524	PBM1E51PW02 ⊕		Zb (2NC)	slow action simultaneous
37-3525	PBM1E51PW20		Zb (2NO)	slow action simultaneous
37-3526	PBM1E51PX21 ⊕		Zb (1NC+2NO)	slow action close before open
37-3527	PBM1E51PX12 ⊕		Zb (2NC+1NO)	slow action open before close
37-3528	PBM1E51PW03 ⊕		Zb (3NC)	slow action simultaneous
37-3529	PBM1E51PW30		Zb (3NO)	slow action simultaneous

• - efficient opening points ⊕ efficient opening $v_{max}=1,5$ [m/s]; $M_{min}=0,15$ [Nm]; $M_{sk}=0,30$ [Nm] Zb - movable contacts are insulated

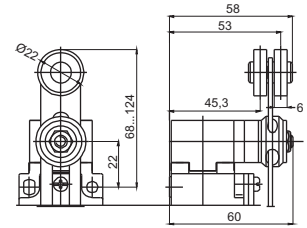

PBM1 limit switches – E52 head adjustable steel roller lever Ø22

Cat. no.	Type	Operating diagram	Connection diagram	Description
37-3530	PBM1E52PZ11 ⊕		Zb (1NO+1NC)	snap action
37-3531	PBM1E52PZ02 ⊕		Zb (2NC)	snap action
37-3532	PBM1E52PX11 ⊕		Zb (1NO+1NC)	slow action open before close
37-3533	PBM1E52PY11 ⊕		Zb (1NO+1NC)	slow action close before open
37-3534	PBM1E52PW02 ⊕		Zb (2NC)	slow action simultaneous
37-3535	PBM1E52PW20		Zb (2NO)	slow action simultaneous
37-3536	PBM1E52PX21 ⊕		Zb (1NC+2NO)	slow action close before open
37-3537	PBM1E52PX12 ⊕		Zb (2NC+1NO)	slow action open before close
37-3538	PBM1E52PW03 ⊕		Zb (3NC)	slow action simultaneous
37-3539	PBM1E52PW30		Zb (3NO)	slow action simultaneous

• - efficient opening points ⊕ efficient opening $v_{max}=1,5$ [m/s]; $M_{min}=0,15$ [Nm]; $M_{sk}=0,30$ [Nm] Zb - movable contacts are insulated

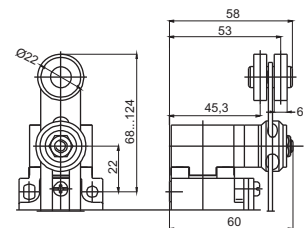

LIMIT SWITCHES

PBM1 limit switches – E54 head adjustable rubber roller lever Ø50

Cat. no.	Type	Operating diagram	Connection diagram	Description
37-3550	PBM1E54PZ11		Zb	(1NO+1NC) snap action
37-3551	PBM1E54PZ02		Zb	(2NC) snap action
37-3552	PBM1E54PX11		Zb	(1NO+1NC) slow action open before close
37-3553	PBM1E54PY11		Zb	(1NO+1NC) slow action close before open
37-3554	PBM1E54PW02		Zb	(2NC) slow action simultaneous
37-3555	PBM1E54PW20		Zb	(2NO) slow action simultaneous
37-3556	PBM1E54PX21		Zb	(1NC+2NO) slow action close before open
37-3557	PBM1E54PX12		Zb	(2NC+1NO) slow action open before close
37-3558	PBM1E54PW03		Zb	(3NC) slow action simultaneous
37-3559	PBM1E54PW30		Zb	(3NO) slow action simultaneous

• - efficient opening points ⊕ efficient opening $v_{max}=1,5$ [m/s]; $M_{min}=0,15$ [Nm]; $M_{sk}=0,30$ [Nm] Zb - movable contacts are insulated

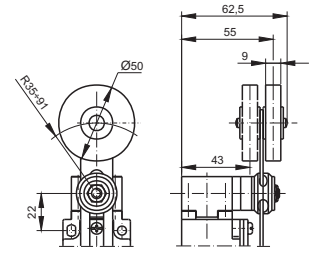

PBM1 limit switches – E61 head steel spring with plastic end

Cat. no.	Type	Operating diagram	Connection diagram	Description
37-3560	PBM1E61PZ11		Zb	(1NO+1NC) snap action
37-3561	PBM1E61PZ02		Zb	(2NC) snap action
37-3562	PBM1E61PX11		Zb	(1NO+1NC) slow action open before close
37-3563	PBM1E61PY11		Zb	(1NO+1NC) slow action close before open
37-3564	PBM1E61PW02		Zb	(2NC) slow action simultaneous
37-3565	PBM1E61PW20		Zb	(2NO) slow action simultaneous
37-3566	PBM1E61PX21		Zb	(1NC+2NO) slow action close before open
37-3567	PBM1E61PX12		Zb	(2NC+1NO) slow action open before close
37-3568	PBM1E61PW03		Zb	(3NC) slow action simultaneous
37-3569	PBM1E61PW30		Zb	(3NO) slow action simultaneous

$v_{max}=1,5$ [m/s]; $M_{min}=0,15$ [Nm] Zb - movable contacts are insulated

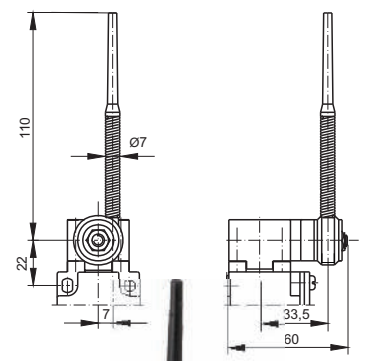

TYPE PBM1

Switch type PBM1 – E62 head steel spring

Cat. no.	Type	Operating diagram	Connection diagram	Description
37-3570	PBM1E62PZ11		Zb	snap action
37-3571	PBM1E62PZ02		Zb	snap action
37-3572	PBM1E62PX11		Zb	slow action open before close
37-3573	PBM1E62PY11		Zb	slow action close before open
37-3574	PBM1E62PW02		Zb	slow action simultaneous
37-3575	PBM1E62PW20		Zb	slow action simultaneous
37-3576	PBM1E62PX21		Zb	slow action close before open
37-3577	PBM1E62PX12		Zb	slow action open before close
37-3578	PBM1E62PW03		Zb	slow action simultaneous
37-3579	PBM1E62PW30		Zb	slow action simultaneous

$v_{max}=1,5$ [m/s]; $M_{min}=0,15$ [Nm] Zb - movable contacts are insulated

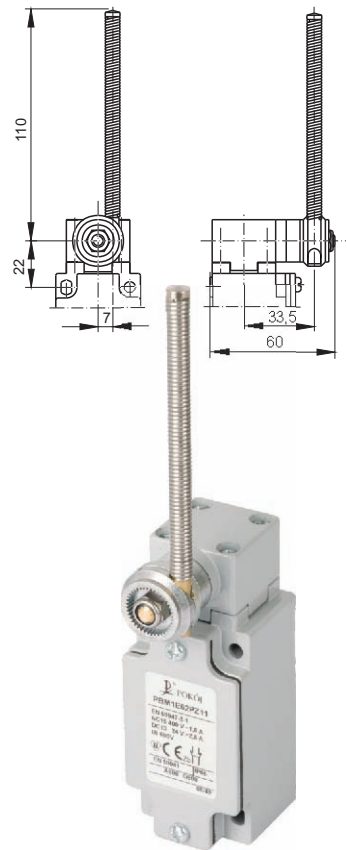

PBM1 limit switches – E71 head stainless steel rod Ø3

Cat. no.	Type	Operating diagram	Connection diagram	Description
37-3580	PBM1E71PZ11 ⊕		Zb	snap action
37-3581	PBM1E71PZ02 ⊕		Zb	snap action
37-3582	PBM1E71PX11 ⊕		Zb	slow action open before close
37-3583	PBM1E71PY11 ⊕		Zb	slow action close before open
37-3584	PBM1E71PW02 ⊕		Zb	slow action simultaneous
37-3585	PBM1E71PW20		Zb	slow action simultaneous
37-3586	PBM1E71PX21 ⊕		Zb	slow action close before open
37-3587	PBM1E71PX12 ⊕		Zb	slow action open before close
37-3588	PBM1E71PW03 ⊕		Zb	slow action simultaneous
37-3589	PBM1E71PW30		Zb	slow action simultaneous

• - efficient opening points ⊕ efficient opening $v_{max}=1,5$ [m/s]; $M_{min}=0,15$ [Nm]; $M_{sk}=0,30$ [Nm] Zb - movable contacts are insulated

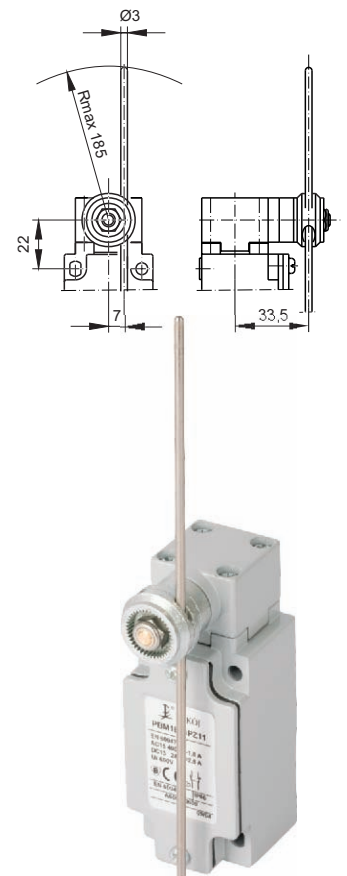

TYPE PBM1

LIMIT SWITCHES

PBM1 limit switches – E72 head plastic rod Ø6

Cat. no.	Type	Operating diagram	Connection diagram	Description
37-3590	PBM1E72PZ11		Zb (1NO+1NC)	snap action
37-3591	PBM1E72PZ02		Zb (2NC)	snap action
37-3592	PBM1E72PX11		Zb (1NO+1NC)	slow action open before close
37-3593	PBM1E72PY11		Zb (1NO+1NC)	slow action close before open
37-3594	PBM1E72PW02		Zb (2NC)	slow action simultaneous
37-3595	PBM1E72PW20		Zb (2NO)	slow action simultaneous
37-3596	PBM1E72PX21		Zb (1NC+2NO)	slow action close before open
37-3597	PBM1E72PX12		Zb (2NC+1NO)	slow action open before close
37-3598	PBM1E72PW03		Zb (3NC)	slow action simultaneous
37-3599	PBM1E72PW30		Zb (3NO)	slow action simultaneous

• - efficient opening points ⊕ efficient opening $v_{max}=1,5$ [m/s]; $M_{min}=0,15$ [Nm]; $M_{sk}=0,30$ [Nm] Zb - movable contacts are insulated

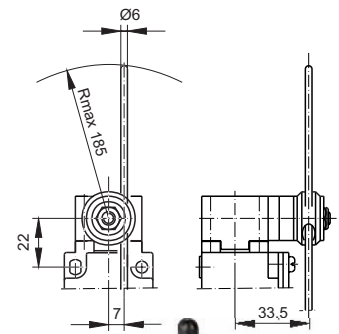

PBM1 limit switches – E91 head steel multidirectional acting spring

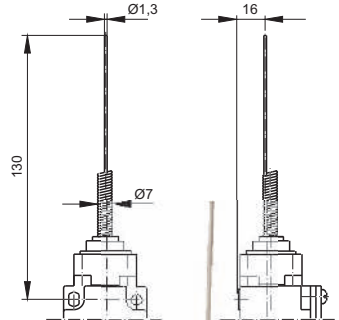

Cat. no.	Type	Operating diagram	Connection diagram	Description
37-3600	PBM1E91PZ11		Zb (1NO+1NC)	snap action
37-3601	PBM1E91PZ02		Zb (2NC)	snap action
37-3602	PBM1E91PX11		Zb (1NO+1NC)	slow action open before close
37-3603	PBM1E91PY11		Zb (1NO+1NC)	slow action close before open
37-3604	PBM1E91PW02		Zb (2NC)	slow action simultaneous
37-3605	PBM1E91PW20		Zb (2NO)	slow action simultaneous
37-3606	PBM1E91PX21		Zb (1NC+2NO)	slow action close before open
37-3607	PBM1E91PX12		Zb (2NC+1NO)	slow action open before close
37-3608	PBM1E91PW03		Zb (3NC)	slow action simultaneous
37-3609	PBM1E91PW30		Zb (3NO)	slow action simultaneous

$v_{max}=1,0$ [m/s]; $M_{min}=0,18$ [Nm] Zb - movable contacts are insulated

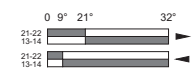
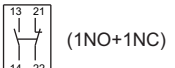
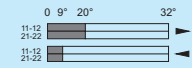
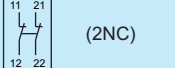
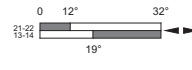
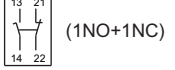
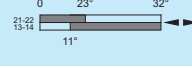
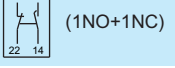

TYPE PBM1

PBM1 limit switches – E92 head steel multidirectional acting spring with plastic end

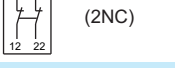
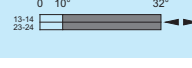
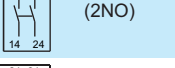
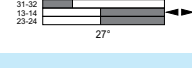
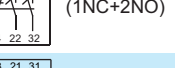
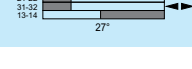
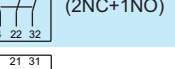
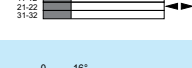
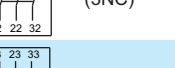
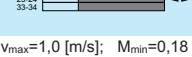
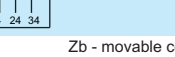
Cat. no.	Type	Operating diagram	Connection diagram	Description
37-3610	PBM1E92PZ11		Zb  (1NO+1NC)	snap action
37-3611	PBM1E92PZ02		Zb  (2NC)	snap action
37-3612	PBM1E92PX11		Zb  (1NO+1NC)	slow action open before close
37-3613	PBM1E92PY11		Zb  (1NO+1NC)	slow action close before open
37-3614	PBM1E92PW02		Zb  (2NC)	slow action simultaneous
37-3615	PBM1E92PW20		Zb  (2NO)	slow action simultaneous
37-3616	PBM1E92PX21		Zb  (1NC+2NO)	slow action close before open
37-3617	PBM1E92PX12		Zb  (2NC+1NO)	slow action open before close
37-3618	PBM1E92PW03		Zb  (3NC)	slow action simultaneous
37-3619	PBM1E92PW30		Zb  (3NO)	slow action simultaneous

$v_{max}=1,0$ [m/s]; $M_{min}=0,18$ [Nm] Zb - movable contacts are insulated

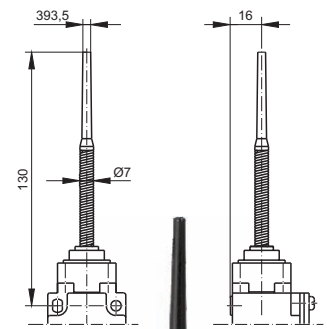

PBM1 limit switches – E93 head steel multidirectional acting long spring

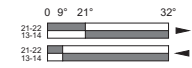
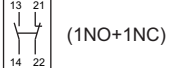
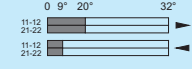
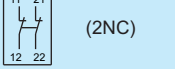
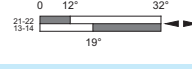
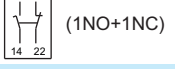
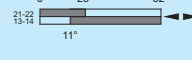
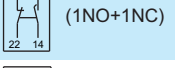
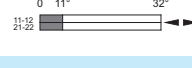
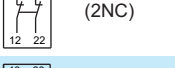
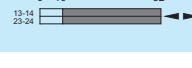
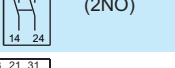
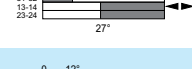
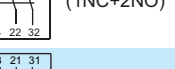
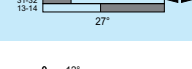
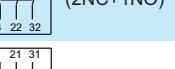
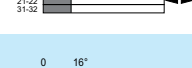
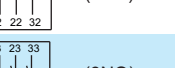
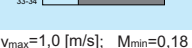
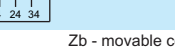



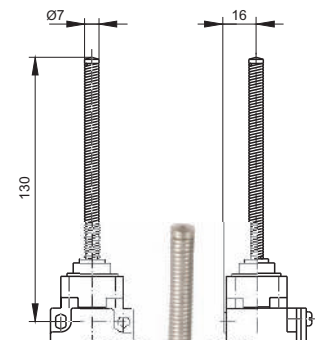

Cat. no.	Type	Operating diagram	Connection diagram	Description
37-3620	PBM1E93PZ11		Zb  (1NO+1NC)	snap action
37-3621	PBM1E93PZ02		Zb  (2NC)	snap action
37-3622	PBM1E93PX11		Zb  (1NO+1NC)	slow action open before close
37-3623	PBM1E93PY11		Zb  (1NO+1NC)	slow action close before open
37-3624	PBM1E93PW02		Zb  (2NC)	slow action simultaneous
37-3625	PBM1E93PW20		Zb  (2NO)	slow action simultaneous
37-3626	PBM1E93PX21		Zb  (1NC+2NO)	slow action close before open
37-3627	PBM1E93PX12		Zb  (2NC+1NO)	slow action open before close
37-3628	PBM1E93PW03		Zb  (3NC)	slow action simultaneous
37-3629	PBM1E93PW30		Zb  (3NO)	slow action simultaneous

$v_{max}=1,0$ [m/s]; $M_{min}=0,18$ [Nm] Zb - movable contacts are insulated

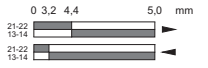
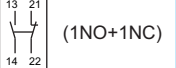
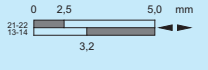
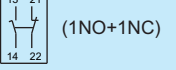

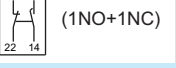
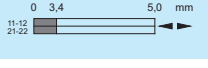
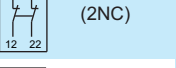
LIMIT SWITCHES

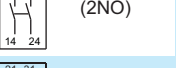
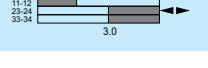
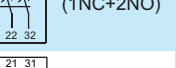
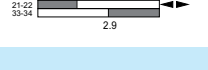
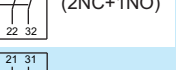
PBM1 limit switches – E99 head activated by pulling the ring

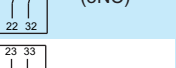
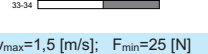
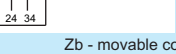
Cat. no.	Type	Operating diagram	Connection diagram	Description
37-3990	PBM1E99PZ11A		Zb  (1NO+1NC)	snap action
37-3992	PBM1E99PX11A		Zb  (1NO+1NC)	slow action open before close
37-3993	PBM1E99PY11A		Zb  (1NO+1NC)	slow action close before open
37-3994	PBM1E99PW02A		Zb  (2NC)	slow action simultaneous
37-3995	PBM1E99PW20A		Zb  (2NO)	slow action simultaneous
37-3996	PBM1E99PX21A		Zb  (1NC+2NO)	slow action close before open
37-3997	PBM1E99PX12A		Zb  (2NC+1NO)	slow action open before close
37-3998	PBM1E99PW03A		Zb  (3NC)	slow action simultaneous
37-3999	PBM1E99PW30A		Zb  (3NO)	slow action simultaneous

$v_{max}=1,5$ [m/s]; $F_{min}=25$ [N]

Zb - movable contacts are insulated

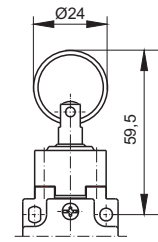

PSBM1 type limit switches

Type PSBM emergency stop limit switches for use in control, monitoring and measurement circuits. They can be installed on tilt, slide or removable machine covers to prevent opening when the machine is energized. The limit switch design prevents uncontrolled switching of contacts using simple tools. Metal body manufactured with attention to details guarantees good tightness. The operating heads can be installed in one of four possible positions. They enable efficient switching of the snap and slow action contact blocks.

Depending on the use, the emergency limit switches are divided into two groups:

- with key – when the machine's cover is removed, the key associated with the switch is removed, and the contacts are switched. Wide range of keys allows the use of the connectors for all possible applications.
- with cord for use in machines and on production lines where it is impossible to install covers. They can be switched from any location along the cord run. A machine is switched off after pulling the cord and when the cord is broken.

The switches feature:

- safety symbol certificate 
- Office of Technical Inspection (UDT) type testing allowing their use in control and signalling systems for cranes and lifts.
- product type approval certification allowing the use on ships granted by Polish Register of Shipping (PRS).

Technical drawings of limit switches in ".dwg" format are available at www.pokoj.com.pl in the section Offer, Design materials.

DIMENSIONS

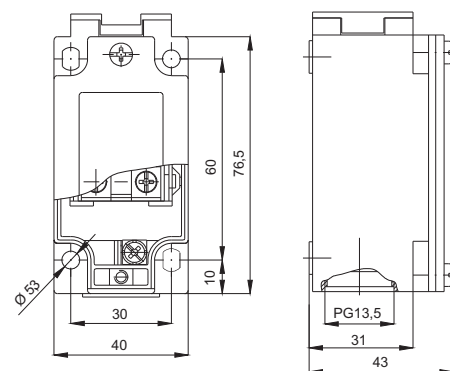

Technical data

TYPE	PSBM1
Standards	IEC 60947-5-1, EN 60947-5-1, EN 50047
Rated switching voltage U_e	AC: 24/120/240/400V 50/60Hz DC: 24/125/250V
Rated switching currents I_e	AC: 10/6/3/1,8A DC: 2,8/0,55/0,27A
Use categories	AC-15, DC-13
Insulation rated voltage U_i (IEC 60947-1)	690V A600, Q600
Nominal impulse withstand voltage U_{imp}	6kV
Protection degree (IEC 60529)	IP65
Environment pollution degree per IEC 60947-1	3
Short-circuiting protection (type and max. values for rated data of the protective device) $U_e < 500V$ a.c. Bi-Wts	10A
Rated conventional air thermal current I_{th} (IEC 60947-5-1) $0 < 40^\circ C$	10A
Electric shock protection (IEC 60536)	Class II
Ambient temperature	-25...+70 °C
Max. switching cycles frequency	3600 cycles/h
Terminal resistance	25mΩ
Terminal cross-section	1 lub 2 x 0,75±2,5mm ²
Installation position	any
Casing material	metal

Accessories

Cat. no.	Type	Page
59-053□	Gland PG 13,5	219

Connection diagrams for limit switches with key describes zero position of contacts (key is plugged in).

LIMIT SWITCHES

PSBM1 limit switches – K435 head head with bent key, 90° adjustable

Cat. no.	Type	Connection diagram	Description
37-CAH0	PSBM1K435PZ11 ⊕	Zb (1NO+1NC)	snap action
37-CAH1	PSBM1K435PZ02 ⊕	Zb (2NC)	snap action
37-CAH2	PSBM1K435PX11 ⊕	Zb (1NO+1NC)	slow action open before close
37-CAH3	PSBM1K435PY11 ⊕	Zb (1NO+1NC)	slow action close before open
37-CAH4	PSBM1K435PW02 ⊕	Zb (2NC)	slow action simultaneous
37-CAH6	PSBM1K435PX21 ⊕	Zb (1NC+2NO)	slow action close before open
37-CAH7	PSBM1K435PX12 ⊕	Zb (2NC+1NO)	slow action open before close
37-CAH8	PSBM1K435PW03 ⊕	Zb (3NC)	slow action simultaneous

⊕ efficient opening Zb - movable contacts are insulated

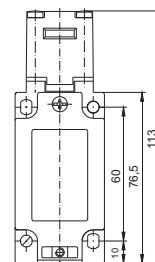







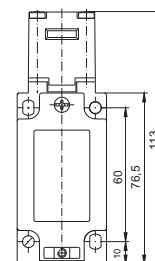

PSBM1 limit switches – K436 head head with narrow key, 90° adjustable

Cat. no.	Type	Connection diagram	Description
37-CAK0	PSBM1K436PZ11 ⊕	Zb (1NO+1NC)	snap action
37-CAK1	PSBM1K436PZ02 ⊕	Zb (2NC)	snap action
37-CAK2	PSBM1K436PX11 ⊕	Zb (1NO+1NC)	slow action open before close
37-CAK3	PSBM1K436PY11 ⊕	Zb (1NO+1NC)	slow action close before open
37-CAK4	PSBM1K436PW02 ⊕	Zb (2NC)	slow action simultaneous
37-CAK6	PSBM1K436PX21 ⊕	Zb (1NC+2NO)	slow action close before open
37-CAK7	PSBM1K436PX12 ⊕	Zb (2NC+1NO)	slow action open before close
37-CAK8	PSBM1K436PW03 ⊕	Zb (3NC)	slow action simultaneous

⊕ efficient opening Zb - movable contacts are insulated



PSBM1 limit switches – K439 head head with adjustable joint key, 90° adjustable

Cat. no.	Type	Connection diagram	Description
37-CAL0	PSBM1K439PZ11	Zb  (1NO+1NC)	snap action
37-CAL1	PSBM1K439PZ02	Zb  (2NC)	snap action
37-CAL2	PSBM1K439PX11	Zb  (1NO+1NC)	slow action open before close
37-CAL3	PSBM1K439PY11	Zb  (1NO+1NC)	slow action close before open
37-CAL4	PSBM1K439PW02	Zb  (2NC)	slow action simultaneous
37-CAL6	PSBM1K439PX21	Zb  (1NC+2NO)	slow action close before open
37-CAL7	PSBM1K439PX12	Zb  (2NC+1NO)	slow action open before close
37-CAL8	PSBM1K439PW03	Zb  (3NC)	slow action simultaneous

⊕ efficient opening Zb - movable contacts are insulated

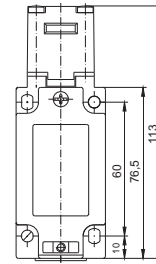



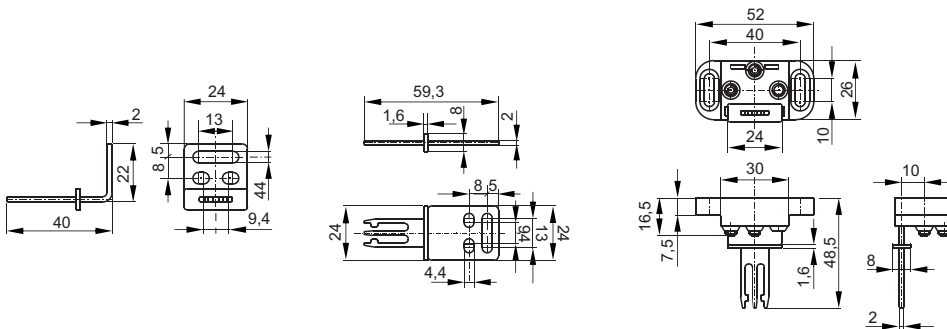



Cat. no.	Type	Cat. no.	Type	Cat. no.	Type
37-8535	Key 35	37-8536	Key 36	37-8539	Key 39



LIMIT SWITCHES

PSBM1 limit switches – K97 head ring pull action





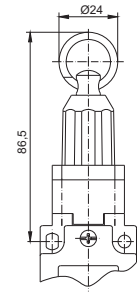

Cat. no.	Type	Operating diagram	Connection diagram	Description
37-CAC2	PSBM1K97PX11 		Zb	slow action open before close
37-CAC3	PSBM1K97PY11 		Zb	slow action close before open
37-CAC4	PSBM1K97PW02 		Zb	slow action simultaneous
37-CAC6	PSBM1K97PX21 		Zb	slow action close before open
37-CAC7	PSBM1K97PX12 		Zb	slow action open before close
37-CAC8	PSBM1K97PW03 		Zb	slow action simultaneous

 efficient opening

Zb - movable contacts are insulated



PSBM1 limit switches – K99 head ring pull action with reset

Cat. no.	Type	Operating diagram	Connection diagram	Description
37-C642	PSBM1K99PX11 		Zb	slow action open before close
37-C643	PSBM1K99PY11 		Zb	slow action close before open
37-C644	PSBM1K99PW02 		Zb	slow action simultaneous
37-C646	PSBM1K99PX21 		Zb	slow action close before open
37-C647	PSBM1K99PX12 		Zb	slow action open before close
37-C648	PSBM1K99PW03 		Zb	slow action simultaneous

 efficient opening

Zb - movable contacts are insulated

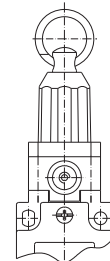

TYPE PSBM1

EMERGENCY STOP LIMIT SWITCHES INSTALLATION DIAGRAM FOR PSBM1 K97...PSBM1 K99...

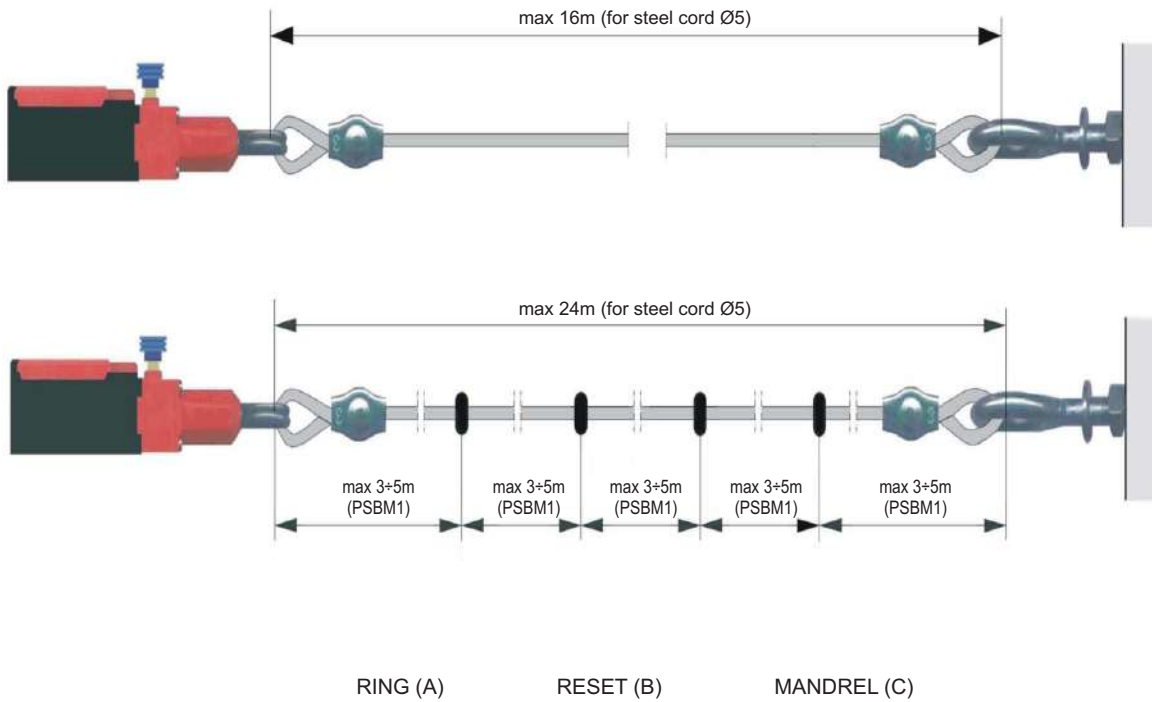

1. **working position** – the mandrel of limit switch is pulled out up to the green ring (A) and reset button is raised (B).
2. **emergency switch off** – pulling the to activate reset (B) results in permanent switch of contacts.
3. **breaking the cord** – backward movement of the mandrel (C) will result in reset action (B) and switching the contacts.

LIMIT SWITCHES

PDM1 type limit switches

Type PDM1 limit switches are designed for work in control, monitoring and measurement circuits, e.g. in machine tools and technological equipment in the food industry, in packaging machines etc. The body is made of metal and the precise workmanship ensures good water tightness. The operating heads are interchangeable and may be installed in one of four possible positions. This does not apply to the following heads: F51, 52, 71 which may be used in one of the possible positions. The operating heads enable efficient switching of the snap and slow action contact blocks.

The switches feature:

- safety symbol certificate 
- Office of Technical Inspection (UDT) type testing allowing their use in control and signalling systems for cranes and lifts.
- product type approval certification allowing the use on ships granted by Polish Register of Shipping (PRS).

Technical drawings of limit switches in ".dwg" format are available at www.pokoj.com.pl in the section Offer, Design materials.

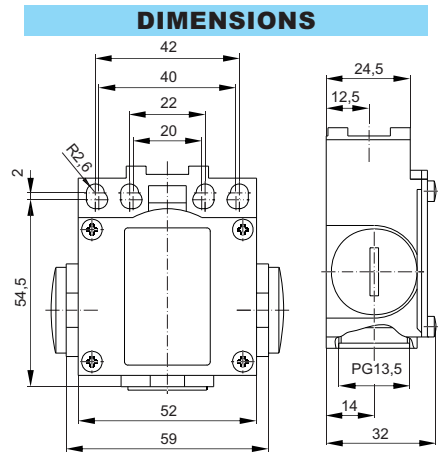













Technical data

TYPE	PDM1
Standards	IEC 60947-5-1, EN 60947-5-1, EN 50047
Rated switching voltage U _e	AC: 24/120/240V 50/60Hz DC: 24/125/250V
Rated switching currents I _e	AC: 10/6/3/1,8A DC: 2,8/0,55/0,27A
Use categories	AC-15, DC-13
Insulation rated voltage U _i (IEC 60947-1)	500V
Nominal impulse withstand voltage U _{imp}	A300, Q300
Protection degree (IEC 60529)	6kV
Environment pollution degree per IEC 60947-1	IP66, IP65 (for F52)
Short-circuiting protection (type and max. values for rated data of the protective device) U _e <500V a.c. Bi-Wts	3
Rated conventional air thermal current I _{th} (IEC 60947-5-1) 0<40°C	10A
Mechanical durability	10A
Electric shock protection (IEC 60536)	F11, F12: 15×10 ⁶ cycles F41, F42, F45: 10×10 ⁶ cycles F51, F52, F71: 10×10 ⁶ cycles
Ambient temperature	Class II
Max. switching cycles frequency	-25...+70 °C
Terminal resistance	3600 cycles/h
Terminal cross-section	25mΩ
Installation position	1 or 2 x 0,75±2,5mm ²
Casing material	any
	metal

Accessories

Cat. no.	Type	Page
59-053□	Gland PG 13,5	219

PDM1 limit switches – F11 head steel plunger

Cat. no.	Type	Operating diagram	Connection diagram	Description
37-5650	PDM1F11PZ11 		Zb  (1NO+1NC)	snap action
37-5651	PDM1F11PZ02 		Zb  (2NC)	snap action
37-5652	PDM1F11PX11 		Zb  (1NO+1NC)	slow action open before close
37-5653	PDM1F11PY11 		Zb  (1NO+1NC)	slow action close before open
37-5654	PDM1F11PW02 		Zb  (2NC)	slow action simultaneous
37-5655	PDM1F11PW20 		Zb  (2NO)	slow action simultaneous

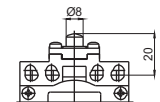

• - efficient opening points  efficient opening v_{max}=0,5 [m/s]; F_{min}=15 [N]; F_{sk}=30 [N] Zb - movable contacts are insulated

PDM1 limit switches – F12 head steel plunger with steel roller Ø11

Cat. no.	Type	Operating diagram	Connection diagram	Description
37-5660	PDM1F12PZ11		Zb	(1NO+1NC) snap action
37-5661	PDM1F12PZ02		Zb	(2NC) snap action
37-5662	PDM1F12PX11		Zb	(1NO+1NC) slow action open before close
37-5663	PDM1F12PY11		Zb	(1NO+1NC) slow action close before open
37-5664	PDM1F12PW02		Zb	(2NC) slow action simultaneous
37-5665	PDM1F12PW20		Zb	(2NO) slow action simultaneous

• - efficient opening points ⊕ efficient opening $v_{max}=0,5$ [m/s]; $F_{min}=12$ [N]; $F_{sk}=30$ [N] Zb - movable contacts are insulated

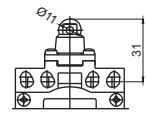

PDM1 limit switches – F41 head plastic roller lever Ø18

Cat. no.	Type	Operating diagram	Connection diagram	Description
37-5670	PDM1F41PZ11		Zb	(1NO+1NC) snap action
37-5671	PDM1F41PZ02		Zb	(2NC) snap action
37-5672	PDM1F41PX11		Zb	(1NO+1NC) slow action open before close
37-5673	PDM1F41PY11		Zb	(1NO+1NC) slow action close before open
37-5674	PDM1F41PW02		Zb	(2NC) slow action simultaneous
37-5675	PDM1F41PW20		Zb	(2NO) slow action simultaneous

• - efficient opening points ⊕ efficient opening $v_{max}=1,5$ [m/s]; $M_{min}=0,10$ [Nm]; $M_{sk}=0,32$ [Nm] Zb - movable contacts are insulated

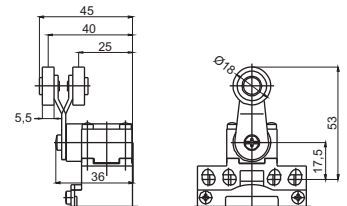

PDM1 limit switches – F42 head rubber roller lever Ø50

Cat. no.	Type	Operating diagram	Connection diagram	Description
37-5680	PDM1F42PZ11		Zb	(1NO+1NC) snap action
37-5681	PDM1F42PZ02		Zb	(2NC) snap action
37-5682	PDM1F42PX11		Zb	(1NO+1NC) slow action open before close
37-5683	PDM1F42PY11		Zb	(1NO+1NC) slow action close before open
37-5684	PDM1F42PW02		Zb	(2NC) slow action simultaneous
37-5685	PDM1F42PW20		Zb	(2NO) slow action simultaneous

• - efficient opening points ⊕ efficient opening $v_{max}=1,5$ [m/s]; $M_{min}=0,10$ [Nm]; $M_{sk}=0,32$ [Nm] Zb - movable contacts are insulated

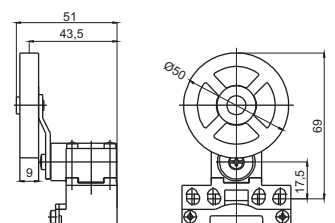

LIMIT SWITCHES

PDM1 limit switches – F45 head long plastic roller lever Ø18

Cat. no.	Type	Operating diagram	Connection diagram	Description
37-5710	PDM1F45PZ11		Zb	1NO+1NC snap action
37-5711	PDM1F45PZ02		Zb	2NC snap action
37-5712	PDM1F45PX11		Zb	1NO+1NC slow action open before close
37-5713	PDM1F45PY11		Zb	1NO+1NC slow action close before open
37-5714	PDM1F45PW02		Zb	2NC slow action simultaneous
37-5715	PDM1F45PW20		Zb	2NO slow action simultaneous

• - efficient opening points ⊕ efficient opening $v_{max}=1,5$ [m/s]; $M_{min}=0,10$ [Nm]; $M_{sk}=0,32$ [Nm] Zb - movable contacts are insulated

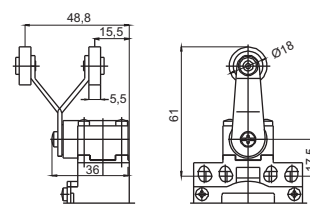

PDM1 limit switches – F51 head adjustable plastic roller lever Ø18

Cat. no.	Type	Operating diagram	Connection diagram	Description
37-5740	PDM1F51PZ11		Zb	1NO+1NC snap action
37-5741	PDM1F51PZ02		Zb	2NC snap action
37-5742	PDM1F51PX11		Zb	1NO+1NC slow action open before close
37-5743	PDM1F51PY11		Zb	1NO+1NC slow action close before open
37-5744	PDM1F51PW02		Zb	2NC slow action simultaneous
37-5745	PDM1F51PW20		Zb	2NO slow action simultaneous

• - efficient opening points ⊕ efficient opening $v_{max}=1,5$ [m/s]; $M_{min}=0,10$ [Nm]; $M_{sk}=0,32$ [Nm] Zb - movable contacts are insulated

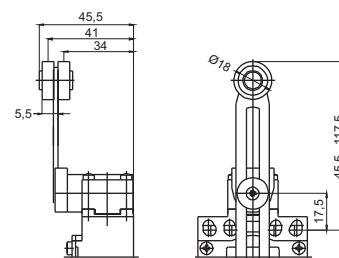

PDM1 limit switches – F52 head adjustable rubber roller lever Ø50

Cat. no.	Type	Operating diagram	Connection diagram	Description
37-5750	PDM1F52PZ11		Zb	1NO+1NC snap action
37-5751	PDM1F52PZ02		Zb	2NC snap action
37-5752	PDM1F52PX11		Zb	1NO+1NC slow action open before close
37-5753	PDM1F52PY11		Zb	1NO+1NC slow action close before open
37-5754	PDM1F52PW02		Zb	2NC slow action simultaneous
37-5755	PDM1F52PW20		Zb	2NO slow action simultaneous

• - efficient opening points ⊕ efficient opening $v_{max}=1,5$ [m/s]; $M_{min}=0,10$ [Nm]; $M_{sk}=0,32$ [Nm] Zb - movable contacts are insulated

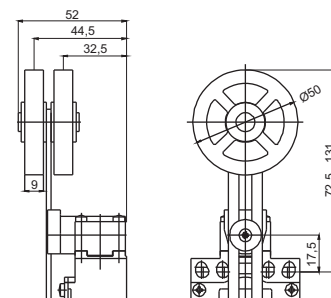

PDM1 limit switches – F71 head stainless steel rod Ø3

Cat. no.	Type	Operating diagram	Connection diagram	Description
37-5770	PDM1F71PZ11 ⊕		Zb (1NO+1NC)	snap action
37-5771	PDM1F71PZ02 ⊕		Zb (2NC)	snap action
37-5772	PDM1F71PX11 ⊕		Zb (1NO+1NC)	slow action open before close
37-5773	PDM1F71PY11 ⊕		Zb (1NO+1NC)	slow action close before open
37-5774	PDM1F71PW02 ⊕		Zb (2NC)	slow action simultaneous
37-5775	PDM1F71PW20		Zb (2NO)	slow action simultaneous

• - efficient opening points ⊕ efficient opening $v_{max}=1,5$ [m/s]; $M_{min}=0,10$ [Nm]; $M_{sk}=0,32$ [Nm] Zb - movable contacts are insulated

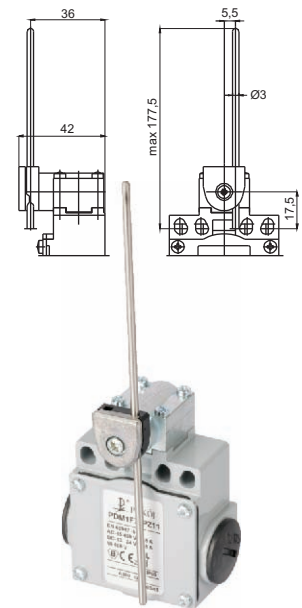

PDM1 limit switches – R11 head steel plunger with reset function

Cat. no.	Type	Connection diagram	Description
37-5R10	PDM1R11PZ11 ⊕	Zb (1NO+1NC)	snap action
37-5R11	PDM1R11PZ02 ⊕	Zb (2NC)	snap action
37-5R12	PDM1R11PX11 ⊕	Zb (1NO+1NC)	slow action open before close
37-5R14	PDM1R11PW02 ⊕	Zb (2NC)	slow action simultaneous

⊕ efficient opening Zb - movable contacts are insulated

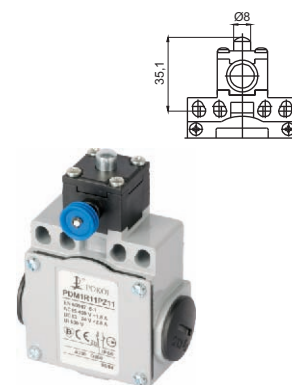

PDM1 limit switches – R13 head steel plunger with plastic roller Ø10.5, with reset function

Cat. no.	Type	Connection diagram	Description
37-5R20	PDM1R13PZ11 ⊕	Zb (1NO+1NC)	snap action
37-5R21	PDM1R13PZ02 ⊕	Zb (2NC)	snap action
37-5R22	PDM1R13PX11 ⊕	Zb (1NO+1NC)	slow action simultaneous
37-5R24	PDM1R13PW02 ⊕	Zb (2NC)	slow action simultaneous

⊕ efficient opening Zb - movable contacts are insulated

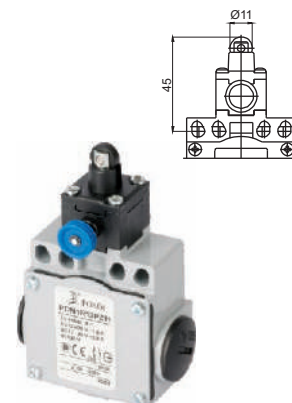

LIMIT SWITCHES

PDM1 limit switches – R31 head steel plunger and horizontal plastic roller lever Ø12.5, with reset function

Cat. no.	Type	Connection diagram	Description
37-5R30	PDM1R31PZ11 ⊕	Zb (1NO+1NC)	snap action
37-5R31	PDM1R31PZ02 ⊕	Zb (2NC)	snap action
37-5R32	PDM1R31PX11 ⊕	Zb (1NO+1NC)	slow action open before close
37-5R34	PDM1R31PW02 ⊕	Zb (2NC)	slow action simultaneous

⊕ efficient opening Zb - movable contacts are insulated

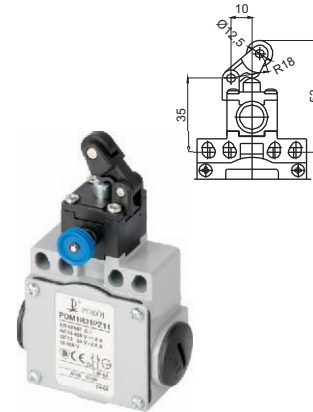

PDM1 limit switches – R38 head steel plunger and plastic roller lever Ø22, with reset function

Cat. no.	Type	Connection diagram	Description
37-5R50	PDM1R38PZ11 ⊕	Zb (1NO+1NC)	snap action
37-5R51	PDM1R38PZ02 ⊕	Zb (2NC)	snap action
37-5R52	PDM1R38PX11 ⊕	Zb (1NO+1NC)	slow action open before close
37-5R54	PDM1R38PW02 ⊕	Zb (2NC)	slow action simultaneous

⊕ efficient opening Zb - movable contacts are insulated

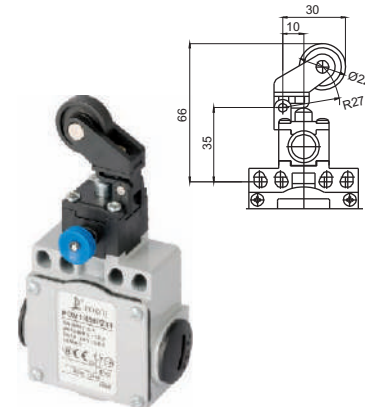

PDM1 limit switches – R41 head plastic roller lever Ø18, with reset function

Cat. no.	Type	Connection diagram	Description
37-5R60	PDM1R41PZ11 ⊕	Zb (1NO+1NC)	snap action
37-5R61	PDM1R41PZ02 ⊕	Zb (2NC)	snap action
37-5R62	PDM1R41PX11 ⊕	Zb (1NO+1NC)	slow action open before close
37-5R64	PDM1R41PW02 ⊕	Zb (2NC)	slow action simultaneous

⊕ efficient opening Zb - movable contacts are insulated

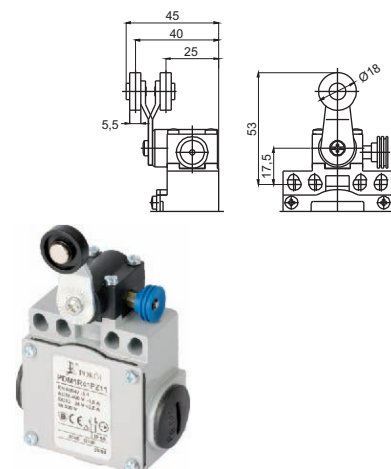

PDP1 type limit switches

Type PDP1 limit switches are designed for work in control, monitoring and measurement circuits, e.g. in machine tools and technological equipment in the food industry, in packaging machines etc. The body is made of high quality plastic and the precise workmanship ensures good water tightness. The operating heads are interchangeable and may be installed in one of four possible positions. The operating heads enable efficient switching of the snap and slow action contact blocks.

The switches feature:

- safety symbol certificate 
- Office of Technical Inspection (UDT) type testing allowing their use in control and signalling systems for cranes and lifts
- product type approval certification allowing the use on ships granted by Polish Register of Shipping (PRS).

Technical drawings of limit switches in ".dwg" format are available at www.pokoj.com.pl in the section Offer, Design materials.

DIMENSIONS

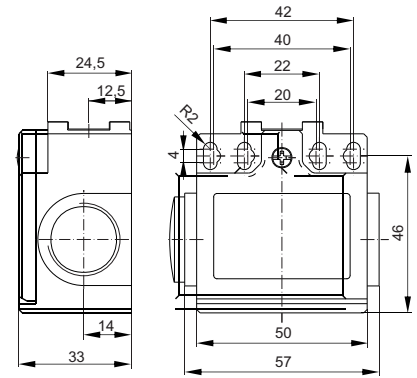







Technical data

TYPE	PDP1
Standards	IEC 60947-5-1, EN 60947-5-1, EN 50047
Rated switching voltage U _e	AC: 24/120/240/400V 50/60Hz DC: 24/125/250V
Rated switching currents I _e	AC: 10/6/3/1,8A DC: 2,8/0,55/0,27A
Use categories	AC-15, DC-13
Insulation rated voltage U _i (IEC 60947-1)	500V
Nominal impulse withstand voltage U _{imp}	A600, Q600
Protection degree (IEC 60529)	IP65
Environment pollution degree per IEC 60947-1	3
Short-circuiting protection (type and max. values for rated data of the protective device) U _e <500V a.c. Bi-Wts	10A
Rated conventional air thermal current I _{th} (IEC 60947-5-1) 0<40°C	10A
Mechanical durability	T11, T31, T38: 15×10 ⁶ cycles T41: 10×10 ⁶ cycles T91, T98: > 5×10 ⁶ cycles
Electric shock protection (IEC 60536)	Class II
Ambient temperature	-25..+70 °C
Max. switching cycles frequency	3600 cycles/h
Terminal resistance	25mΩ
Terminal cross-section	1 or 2 x 0,75+2,5mm ²
Installation position	any
Casing material	plastic

Accessories

Cat. no.	Type	Page
59-053□	Gland PG 13,5	219

PDP1 limit switches – T11 head steel plunger

Cat. no.	Type	Operating diagram	Connection diagram	Description
37-6020	PDP1T11PZ11 		Zb	snap action
37-6021	PDP1T11PZ02 		Zb	snap action
37-6022	PDP1T11PX11 		Zb	slow action open before close
37-6023	PDP1T11PY11 		Zb	slow action close before open
37-6024	PDP1T11PW02 		Zb	slow action simultaneous
37-6025	PDP1T11PW20 		Zb	slow action simultaneous

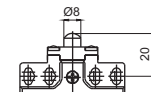

• - efficient opening points  efficient opening v_{max}=0,5 [m/s]; F_{min}=15 [N]; F_{sk}=30 [N] Zb - movable contacts are insulated

LIMIT SWITCHES

PDP1 limit switches – T31 head steel plunger and horizontal plastic roller lever Ø12.5

Cat. no.	Type	Operating diagram	Connection diagram	Description
37-6050	PDP1T31PZ11		Zb (1NO+1NC)	snap action
37-6051	PDP1T31PZ02		Zb (2NC)	snap action
37-6052	PDP1T31PX11		Zb (1NO+1NC)	slow action open before close
37-6053	PDP1T31PY11		Zb (1NO+1NC)	slow action close before open
37-6054	PDP1T31PW02		Zb (2NC)	slow action simultaneous
37-6055	PDP1T31PW20		Zb (2NO)	slow action simultaneous

• - efficient opening points ⊕ efficient opening $v_{max}=1.0$ [m/s]; $F_{min}=7$ [N]; $F_{sk}=24$ [N] Zb - movable contacts are insulated

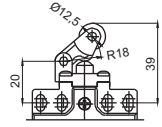

PDP1 limit switches – T38 head steel plunger and plastic roller lever Ø22

Cat. no.	Type	Operating diagram	Connection diagram	Description
37-6970	PDP1T38PZ11		Zb (1NO+1NC)	snap action
37-6971	PDP1T38PZ02		Zb (2NC)	snap action
37-6972	PDP1T38PX11		Zb (1NO+1NC)	slow action open before close
37-6973	PDP1T38PY11		Zb (1NO+1NC)	slow action close before open
37-6974	PDP1T38PW02		Zb (2NC)	slow action simultaneous
37-6975	PDP1T38PW20		Zb (2NO)	slow action simultaneous

• - efficient opening points ⊕ efficient opening $v_{max}=1.0$ [m/s]; $F_{min}=7$ [N]; $F_{sk}=24$ [N] Zb - movable contacts are insulated

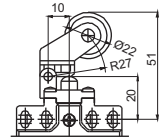

PDP1 limit switches – T41 head plastic roller lever Ø18

Cat. no.	Type	Operating diagram	Connection diagram	Description
37-6080	PDP1T41PZ11		Zb (1NO+1NC)	snap action
37-6081	PDP1T41PZ02		Zb (2NC)	snap action
37-6082	PDP1T41PX11		Zb (1NO+1NC)	slow action open before close
37-6083	PDP1T41PY11		Zb (1NO+1NC)	slow action close before open
37-6084	PDP1T41PW02		Zb (2NC)	slow action simultaneous
37-6085	PDP1T41PW20		Zb (2NO)	slow action simultaneous

• - efficient opening points ⊕ efficient opening $v_{max}=1.5$ [m/s]; $M_{min}=0.1$ [Nm]; $M_{sk}=0.32$ [Nm] Zb - movable contacts are insulated

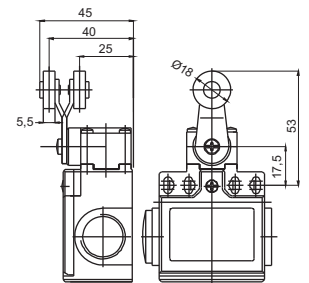

PDP1 limit switches – T91 head stainless steel multidirectional action spring

Cat. no.	Type	Operating diagram	Connection diagram	Description
37-6150	PDP1T91PZ11		Zb (1NO+1NC)	snap action
37-6151	PDP1T91PZ02		Zb (2NC)	snap action
37-6152	PDP1T91PX11		Zb (1NO+1NC)	slow action open before close
37-6153	PDP1T91PY11		Zb (1NO+1NC)	slow action close before open
37-6154	PDP1T91PW02		Zb (2NC)	slow action simultaneous
37-6155	PDP1T91PW20		Zb (2NO)	slow action simultaneous

$v_{max}=1,0$ [m/s]; $M_{min}=0,12$ [Nm] Zb - movable contacts are insulated

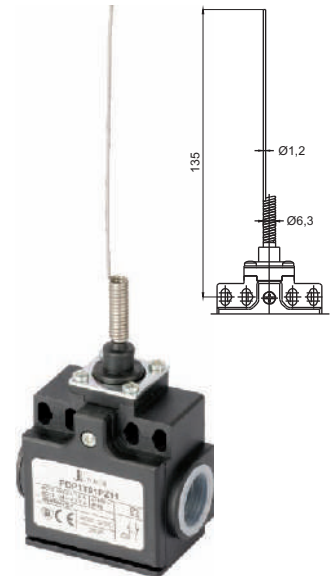

PDP1 limit switches – T98 head ring pull action

Cat. no.	Type	Operating diagram	Connection diagram	Description
37-6980	PDP1T98PZ11A		Zb (1NO+1NC)	snap action
37-6982	PDP1T98PX11A		Zb (1NO+1NC)	slow action open before close
37-6983	PDP1T98PY11A		Zb (1NO+1NC)	slow action close before open
37-6984	PDP1T98PW02A		Zb (2NC)	slow action simultaneous
37-6985	PDP1T98PW20A		Zb (2NO)	slow action simultaneous

$v_{max}=0,5$ [m/s]; $F_{min}=30$ [N] Zb - movable contacts are insulated

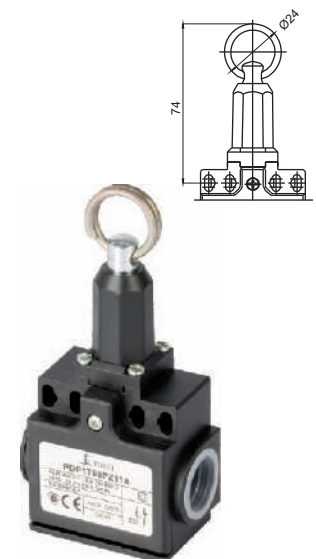

PDP1 limit switches – R11 head steel plunger with reset function

Cat. no.	Type	Connection diagram	Description
37-6R10	PDP1R11PZ11 ⊕	Zb (1NO+1NC)	snap action
37-6R11	PDP1R11PZ02 ⊕	Zb (2NC)	snap action
37-6R12	PDP1R11PX11 ⊕	Zb (1NO+1NC)	slow action open before close
37-6R14	PDP1R11PW02 ⊕	Zb (2NC)	slow action simultaneous



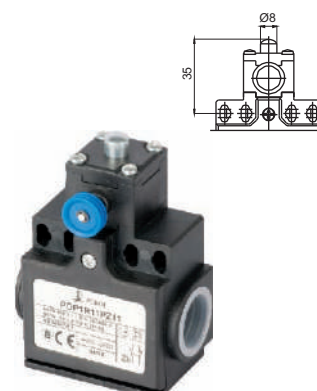

⊕ efficient opening Zb - movable contacts are insulated



TYPE PDP1

LIMIT SWITCHES



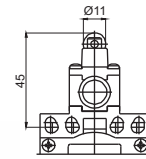

PDP1 limit switches – R13 head steel plunger with plastic roller $\varnothing 10.5$, with reset function

Cat. no.	Type	Connection diagram	Description
37-6R20	PDP1R13PZ11 \ominus	Zb  (1NO+1NC)	snap action
37-6R21	PDP1R13PZ02 \ominus	Zb  (2NC)	snap action
37-6R22	PDP1R13PX11 \ominus	Zb  (1NO+1NC)	slow action open before close
37-6R24	PDP1R13PW02 \ominus	Zb  (2NC)	slow action simultaneous

\ominus efficient opening Zb - movable contacts are insulated





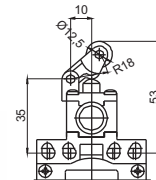

PDP1 limit switches – R31 head steel plunger and horizontal plastic roller lever $\varnothing 12.5$, with reset function

Cat. no.	Type	Connection diagram	Description
37-6R30	PDP1R31PZ11 \ominus	Zb  (1NO+1NC)	snap action
37-6R31	PDP1R31PZ02 \ominus	Zb  (2NC)	snap action
37-6R32	PDP1R31PX11 \ominus	Zb  (1NO+1NC)	slow action open before close
37-6R34	PDP1R31PW02 \ominus	Zb  (2NC)	slow action simultaneous

\ominus efficient opening Zb - movable contacts are insulated









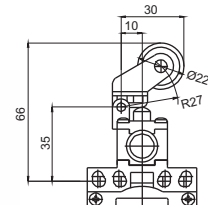

PDP1 limit switches – R38 head steel plunger and plastic roller lever $\varnothing 22$, with reset function

Cat. no.	Type	Connection diagram	Description
37-6R50	PDP1R38PZ11 \ominus	Zb  (1NO+1NC)	snap action
37-6R51	PDP1R38PZ02 \ominus	Zb  (2NC)	snap action
37-6R52	PDP1R38PX11 \ominus	Zb  (1NO+1NC)	slow action open before close
37-6R54	PDP1R38PW02 \ominus	Zb  (2NC)	slow action simultaneous

\ominus efficient opening Zb - movable contacts are insulated



PDP1 limit switches – R41 head plastic roller lever Ø18, with reset function

Cat. no.	Type	Connection diagram	Description
37-6R60	PDP1R41PZ11 	Zb  (1NO+1NC)	snap action
37-6R61	PDP1R41PZ02 	Zb  (2NC)	snap action
37-6R62	PDP1R41PX11 	Zb  (1NO+1NC)	slow action open before close
37-6R64	PDP1R41PW02 	Zb  (2NC)	slow action simultaneous

 efficient opening Zb - movable contacts are insulated

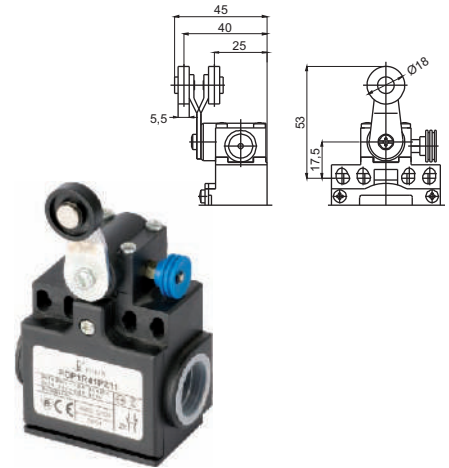

LIMIT SWITCHES

PEM1 type limit switches

Type PEM1 limit switches are designed for work in control, monitoring and measurement circuits, e.g. in machine tools and technological equipment in the food industry, in packaging machines etc. The body is made of metal and the precise workmanship ensures good water tightness. They enable efficient switching of the snap and slow action contact blocks. The conductor is permanently fixed which guarantees durable and very good tightness. Small dimensions enable installation in all places with limited installation area.

Technical drawings of limit switches in ".dwg" format are available at www.pokoj.com.pl in the section Offer, Design materials.

DIMENSIONS

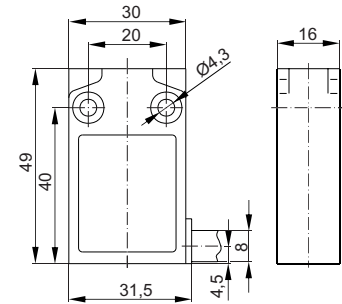

Technical data

TYPE	PEM1
Standards	IEC 60947-5-1, EN 60947-5-1
Rated switching voltage U _e	AC: 24/120/240V 50/60Hz DC: 24/125/250V
Rated switching currents I _e	AC: 5/3/1,5A DC: 1,1/0,22/0,1A
Use categories	AC-15, DC-13
Insulation rated voltage U _i (IEC 60947-1)	400V
Nominal impulse withstand voltage U _{imp}	B300, R300
Protection degree (IEC 60529)	4kV
Environment pollution degree per IEC 60947-1	IP67
Short-circuiting protection (type and max. values for rated data of the protective device) U _e <500V a.c. Bi-Wts	3
Rated conventional air thermal current I _{th} (IEC 60947-5-1) 0<40°C	6A
Mechanical durability	5A
Electric shock protection (IEC 60536)	10×10 ⁶ cycles
Ambient temperature	Class I
Max. switching cycles frequency	-25...+70 °C
Terminal resistance	3600 cycles/h
Connectors marking	25mΩ
Length of terminals	IEC 60445
Terminal cross-section	1m
Casing material	5 x 0,75mm ² metal

PEM1 limit switches – G11 head metal plunger

Cat. no.	Type	Operating diagram	Connection diagram	Description
37-A82Z	PEM1G11Z			snap action
37-A82X	PEM1G11X			slow action

• - efficient opening points ⊕ efficient opening v_{max}=0,5 [m/s]; F_{min}=15 [N]; F_{sk}=30 [N] Zb - movable contacts are insulated

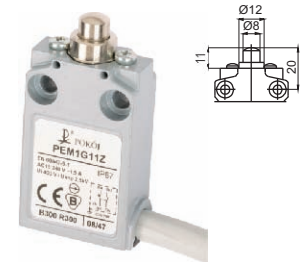

PEM1 limit switches – G12 head metal plunger with parallel steel roller Ø12

Cat. no.	Type	Operating diagram	Connection diagram	Description
37-A83Z	PEM1G12Z			snap action
37-A83X	PEM1G12X			slow action

• - efficient opening points ⊕ efficient opening v_{max}=0,1 [m/s]; F_{min}=10 [N]; F_{sk}=30 [N] Zb - movable contacts are insulated

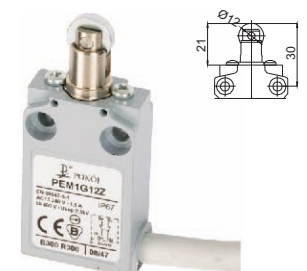

PEM1 limit switches – G13 head metal plunger with parallel plastic roller Ø12

Cat. no.	Type	Operating diagram	Connection diagram	Description
37-A84Z	PEM1G13Z			snap action
37-A84X	PEM1G13X			slow action

• - efficient opening points ⊕ efficient opening $v_{max}=0,1$ [m/s]; $F_{min}=10$ [N]; $F_{sk}=30$ [N] Zb - movable contacts are insulated

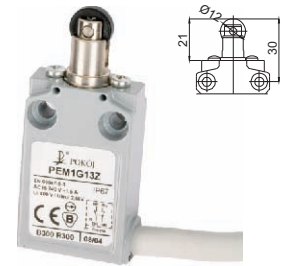

PEM1 limit switches – G14 head metal plunger with perpendicular steel roller Ø12

Cat. no.	Type	Operating diagram	Connection diagram	Description
37-A85Z	PEM1G14Z			snap action
37-A85X	PEM1G14X			slow action

• - efficient opening points ⊕ efficient opening $v_{max}=0,1$ [m/s]; $F_{min}=10$ [N]; $F_{sk}=30$ [N] Zb - movable contacts are insulated

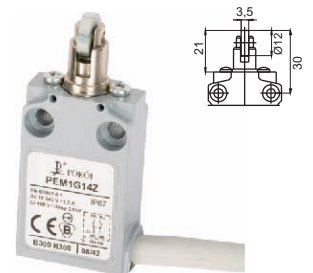

PEM1 limit switches – G15 head metal plunger with perpendicular plastic roller Ø12

Cat. no.	Type	Operating diagram	Connection diagram	Description
37-A86Z	PEM1G15Z			snap action
37-A86X	PEM1G15X			slow action

• - efficient opening points ⊕ efficient opening $v_{max}=0,1$ [m/s]; $F_{min}=10$ [N]; $F_{sk}=30$ [N] Zb - movable contacts are insulated

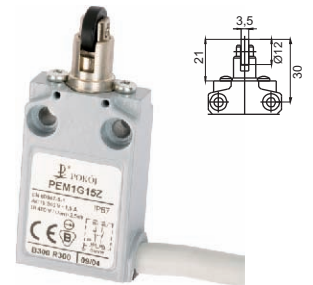

PEM1 limit switches – G21 head metal plunger with additional fitting on threaded head

Cat. no.	Type	Operating diagram	Connection diagram	Description
37-A87Z	PEM1G21Z			snap action
37-A87X	PEM1G21X			slow action

• - efficient opening points ⊕ efficient opening $v_{max}=0,5$ [m/s]; $F_{min}=15$ [N]; $F_{sk}=30$ [N] Zb - movable contacts are insulated

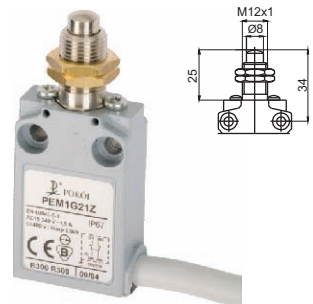

PEM1 limit switches – G22 head parallel steel roller Ø10.4 with additional fitting on threaded head

Cat. no.	Type	Operating diagram	Connection diagram	Description
37-A88Z	PEM1G22Z			snap action
37-A88X	PEM1G22X			slow action

• - efficient opening points ⊕ efficient opening $v_{max}=0,1$ [m/s]; $F_{min}=10$ [N]; $F_{sk}=30$ [N] Zb - movable contacts are insulated

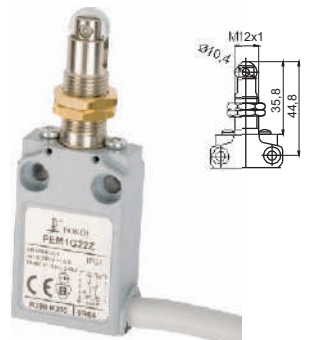

PEM1 limit switches – G23 head parallel plastic roller Ø10.7 with additional fitting on threaded head

Cat. no.	Type	Operating diagram	Connection diagram	Description
37-A89Z	PEM1G23Z			snap action
37-A89X	PEM1G23X			slow action

• - efficient opening points ⊕ efficient opening $v_{max}=0,1$ [m/s]; $F_{min}=10$ [N]; $F_{sk}=30$ [N] Zb - movable contacts are insulated



LIMIT SWITCHES

PEM1 limit switches – G24 head perpendicular steel roller Ø10.4 with additional fitting on threaded head

Cat. no.	Type	Operating diagram	Connection diagram	Description
37-A90Z	PEM1G24Z			snap action
37-A90X	PEM1G24X			slow action

• - efficient opening points ⊕ efficient opening $v_{max}=0,1$ [m/s]; $F_{min}=10$ [N]; $F_{sk}=30$ [N] Zb - movable contacts are insulated

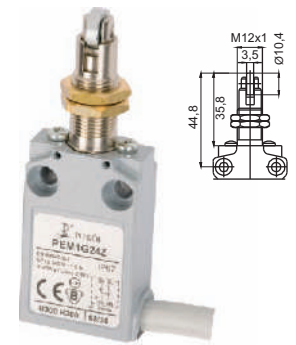

PEM1 limit switches – G25 head parallel plastic roller Ø10.7 with additional fitting on threaded head

Cat. no.	Type	Operating diagram	Connection diagram	Description
37-A91Z	PEM1G25Z			snap action
37-A91X	PEM1G25X			slow action

• - efficient opening points ⊕ efficient opening $v_{max}=0,1$ [m/s]; $F_{min}=10$ [N]; $F_{sk}=30$ [N] Zb - movable contacts are insulated

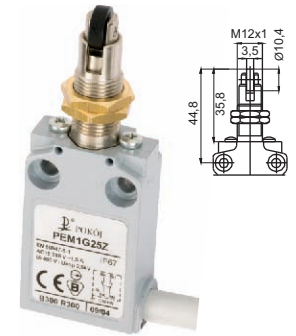

PEM1 limit switches – G41 head plastic roller lever Ø14

Cat. no.	Type	Operating diagram	Connection diagram	Description
37-A92Z	PEM1G41Z			snap action
37-A92X	PEM1G41X			slow action

• - efficient opening points ⊕ efficient opening $v_{max}=1,5$ [m/s]; $M_{min}=0,08$ [Nm]; $M_{sk}=0,28$ [Nm] Zb - movable contacts are insulated

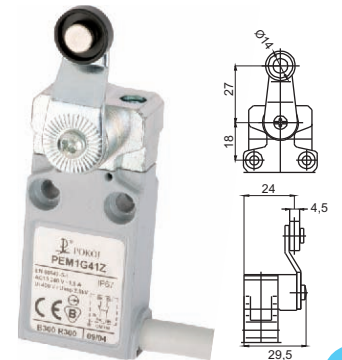

PEM1 limit switches – G42 head metal roller lever Ø14

Cat. no.	Type	Operating diagram	Connection diagram	Description
37-A93Z	PEM1G42Z			snap action
37-A93X	PEM1G42X			slow action

• - efficient opening points ⊕ efficient opening $v_{max}=1,5$ [m/s]; $M_{min}=0,08$ [Nm]; $M_{sk}=0,28$ [Nm] Zb - movable contacts are insulated

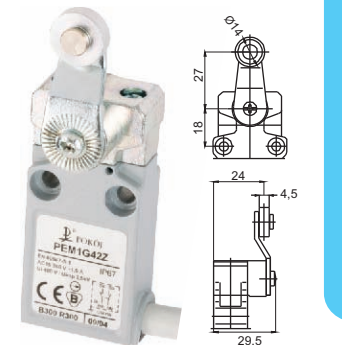

PEM1 limit switches – G51 head adjustable plastic roller lever Ø18

Cat. no.	Type	Operating diagram	Connection diagram	Description
37-A95Z	PEM1G51Z			snap action
37-A95X	PEM1G51X			slow action

• - efficient opening points ⊕ efficient opening $v_{max}=1,5$ [m/s]; $M_{min}=0,08$ [Nm]; $M_{sk}=0,28$ [Nm] Zb - movable contacts are insulated

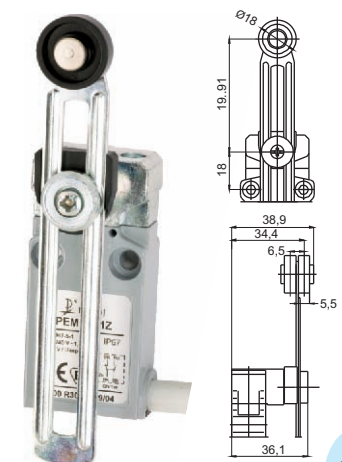

TYPE PEM1

PEM2 type limit switches

Type PEM2 limit switches are designed for work in control, monitoring and measurement circuits, e.g. in machine tools and technological equipment in the food industry, in packaging machines etc. The body is made of metal and the precise workmanship ensures good water tightness. They enable efficient switching of the snap and slow action contact blocks. The conductor is permanently fixed which guarantees durable and very good tightness. Small dimensions enable installation in all places with limited installation area.

Technical drawings of limit switches in ".dwg" format are available at www.pokoj.com.pl in the section Offer, Design materials.

DIMENSIONS

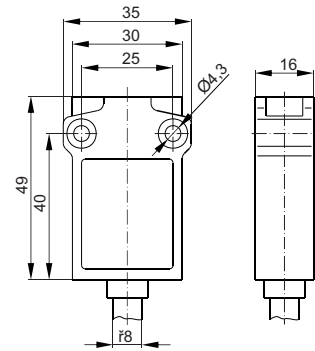

Technical data

TYPE	PEM2
Standards	IEC 60947-5-1, EN 60947-5-1
Rated switching voltage U _e	AC: 24/120/240V 50/60Hz DC: 24/125/250V
Rated switching currents I _e	AC: 5/3/1,5A DC: 1,1/0,22/0,1A
Use categories	AC-15, DC-13
Insulation rated voltage U _i (IEC 60947-1)	400V
Nominal impulse withstand voltage U _{imp}	B300, R300
Protection degree (IEC 60529)	4kV
Environment pollution degree per IEC 60947-1	IP67
Short-circuiting protection (type and max. values for rated data of the protective device) U _e <500V a.c. Bi-Wts	3
Rated conventional air thermal current I _{th} (IEC 60947-5-1) 0<40°C	6A
Mechanical durability	5A
Electric shock protection (IEC 60536)	10×10 ⁶ cycles
Ambient temperature	Class I
Max. switching cycles frequency	-25...+70 °C
Terminal resistance	3600 cycles/h
Connectors marking	25mΩ
Length of terminals	IEC 60445
Terminal cross-section	1m
Casing material	5 x 0,75mm ²
	metal

PEM2 limit switches – G11 head metal plunger

Cat. no.	Type	Operating diagram	Connection diagram	Description
37-B82Z	PEM2G11Z			snap action
37-B82X	PEM2G11X			slow action

• - efficient opening points ⊕ efficient opening v_{max}=0,5 [m/s]; F_{min}=15 [N]; F_{sk}=30 [N] Zb - movable contacts are insulated

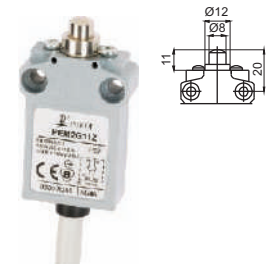

PEM2 limit switches – G12 head metal plunger with parallel steel roller Ø12

Cat. no.	Type	Operating diagram	Connection diagram	Description
37-B83Z	PEM2G12Z			snap action
37-B83X	PEM2G12X			slow action

• - efficient opening points ⊕ efficient opening v_{max}=0,1 [m/s]; F_{min}=10 [N]; F_{sk}=30 [N] Zb - movable contacts are insulated

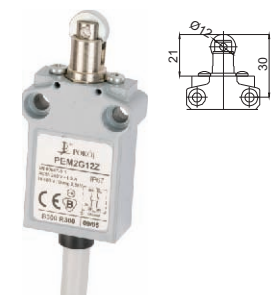

LIMIT SWITCHES

PEM2 limit switches – G13 head metal plunger with parallel plastic roller Ø12

Cat. no.	Type	Operating diagram	Connection diagram	Description
37-B84Z	PEM2G13Z			snap action
37-B84X	PEM2G13X			slow action

• - efficient opening points ⊕ efficient opening $v_{max}=0,1$ [m/s]; $F_{min}=10$ [N]; $F_{sk}=30$ [N] Zb - movable contacts are insulated

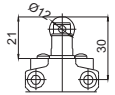

PEM2 limit switches – G14 head metal plunger with perpendicular steel roller Ø12

Cat. no.	Type	Operating diagram	Connection diagram	Description
37-B85Z	PEM2G14Z			snap action
37-B85X	PEM2G14X			slow action

• - efficient opening points ⊕ efficient opening $v_{max}=0,1$ [m/s]; $F_{min}=10$ [N]; $F_{sk}=30$ [N] Zb - movable contacts are insulated

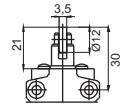

PEM2 limit switches – G15 head metal plunger with perpendicular plastic roller Ø12

Cat. no.	Type	Operating diagram	Connection diagram	Description
37-B86Z	PEM2G15Z			snap action
37-B86X	PEM2G15X			slow action

• - efficient opening points ⊕ efficient opening $v_{max}=0,1$ [m/s]; $F_{min}=10$ [N]; $F_{sk}=30$ [N] Zb - movable contacts are insulated

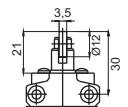

PEM2 limit switches – G21 head metal plunger with additional fitting on threaded head

Cat. no.	Type	Operating diagram	Connection diagram	Description
37-B87Z	PEM2G21Z			snap action
37-B87X	PEM2G21X			slow action

• - efficient opening points ⊕ efficient opening $v_{max}=0,5$ [m/s]; $F_{min}=15$ [N]; $F_{sk}=30$ [N] Zb - movable contacts are insulated

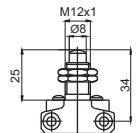

PEM2 limit switches – G22 head parallel steel roller Ø10.4 with additional fitting on threaded head

Cat. no.	Type	Operating diagram	Connection diagram	Description
37-B88Z	PEM2G22Z			snap action
37-B88X	PEM2G22X			slow action

• - efficient opening points ⊕ efficient opening $v_{max}=0,1$ [m/s]; $F_{min}=10$ [N]; $F_{sk}=30$ [N] Zb - movable contacts are insulated

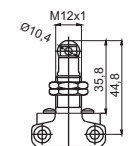

PEM2 limit switches – G23 head perpendicular steel roller Ø10.4 with additional fitting on threaded head

Cat. no.	Type	Operating diagram	Connection diagram	Description
37-B89Z	PEM2G23Z			snap action
37-B89X	PEM2G23X			slow action

• - efficient opening points ⊕ efficient opening $v_{max}=0,1$ [m/s]; $F_{min}=10$ [N]; $F_{sk}=30$ [N] Zb - movable contacts are insulated

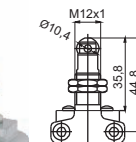

PEM2 limit switches – G24 head perpendicular steel roller Ø10.4 with additional fitting on threaded head

Cat. no.	Type	Operating diagram	Connection diagram	Description
37-B90Z	PEM2G24Z			snap action
37-B90X	PEM2G24X			slow action

• - efficient opening points efficient opening $v_{max}=0,1$ [m/s]; $F_{min}=10$ [N]; $F_{sk}=30$ [N] Zb - movable contacts are insulated

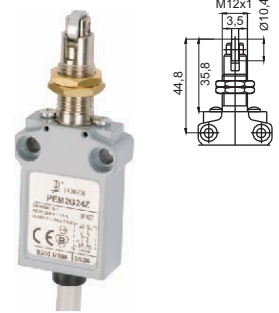

PEM2 limit switches – G25 head perpendicular plastic roller Ø10.7 with additional fitting on threaded head

Cat. no.	Type	Operating diagram	Connection diagram	Description
37-B91Z	PEM2G25Z			snap action
37-B91X	PEM2G25X			slow action

• - efficient opening points efficient opening $v_{max}=0,1$ [m/s]; $F_{min}=10$ [N]; $F_{sk}=30$ [N] Zb - movable contacts are insulated

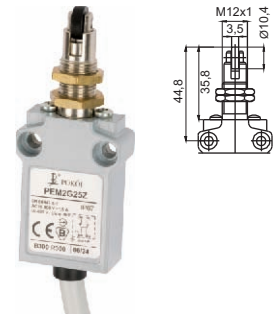

PEM2 limit switches – G41 head plastic roller lever Ø14

Cat. no.	Type	Operating diagram	Connection diagram	Description
37-B92Z	PEM2G41Z			snap action
37-B92X	PEM2G41X			slow action

• - efficient opening points efficient opening $v_{max}=1,5$ [m/s]; $M_{min}=0,08$ [Nm]; $M_{sk}=0,28$ [Nm] Zb - movable contacts are insulated

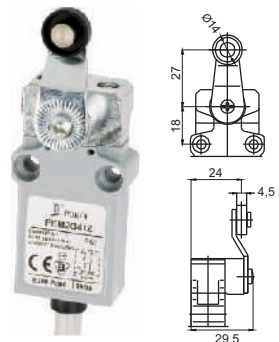

PEM2 limit switches – G42 head metal roller lever Ø14

Cat. no.	Type	Operating diagram	Connection diagram	Description
37-B93Z	PEM2G42Z			snap action
37-B93X	PEM2G42X			slow action

• - efficient opening points efficient opening $v_{max}=1,5$ [m/s]; $M_{min}=0,08$ [Nm]; $M_{sk}=0,28$ [Nm] Zb - movable contacts are insulated

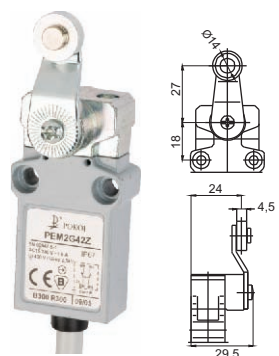

PEM2 limit switches – G51 head adjustable plastic roller lever Ø18

Cat. no.	Type	Operating diagram	Connection diagram	Description
37-B95Z	PEM2G51Z			snap action
37-B95X	PEM2G51X			slow action

• - efficient opening points efficient opening $v_{max}=1,5$ [m/s]; $M_{min}=0,08$ [Nm]; $M_{sk}=0,28$ [Nm] Zb - movable contacts are insulated

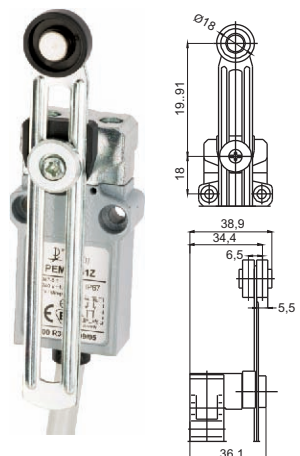

LIMIT SWITCHES

KLM type limit switches

KLM type limit switches are designed for use in signalling, protection and monitoring circuits. The limit switch is activated by a driving device. The force applied to the plunger lever switches the movable contacts. When the driving force ceases, the spring force causes movable contacts to return to the starting position.

Technical drawings of limit switches in ".dwg" format are available at www.pokoj.com.pl in the section Offer, Design materials.

DIMENSIONS

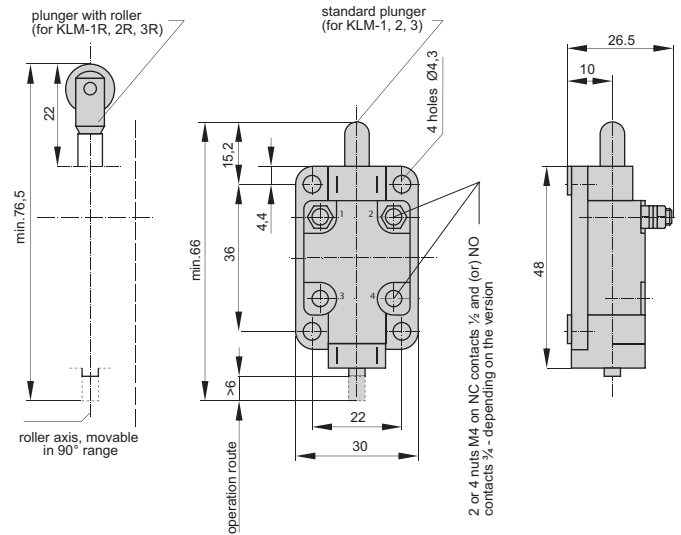

Technical data

TYPE	KLM
Standards	IEC 60947-5-1
Rated switching voltage Ue	AC: 230/400/500 V DC: 48/110/220 V
Rated switching currents Ie	AC: 4/4/2,5 A DC: 1,6/0,6/0,25 A
Use categories	AC-15 DC-15
Nominal voltage of insulation Ui	500 V
Nominal impulse withstand voltage Uimp	4 kV
Protection class	IP 00
Environmental pollution level	3
Short-circuiting protection	Bi-Wts 25 A
Max. force to apply to the drive unit	50N
Movement parameters of the element activating the switch: The direction of driving force should match the direction of movement plunger but deviations of the force direction are allowed: a) by 15 degrees in all directions in relation to the plunger axis b) by 30 degrees in relation to the plunger axis with the roller operating in perpendicular to the axis of plunger roller	
Speed of the drive unit	0,1...5m/s
Drive unit stroke	6±0,5mm
Terminal cross-section	0,75...4 mm ²
Ambient temperature	-20...+40°C
Force required to change the position of the contact's terminals	9,8N
Working position	any
The allowed degree of increase of mechanical stresses is: a) 2 _{gn} for continuous acceleration and harmonic vibration 5...50 Hz b) 10 _{gn} for shocks	
gn - gravitational acceleration	

KLM switches straight plunger

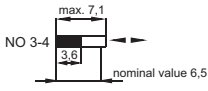
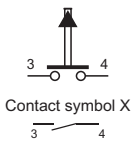
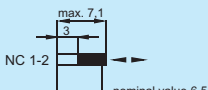
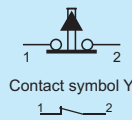
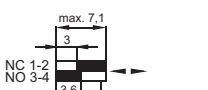
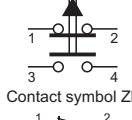
Cat. no.	Type	Operating diagram	Connection diagram	Description
36-1000	KLM1			normally open
36-2000	KLM2			normally closed
36-3000	KLM3			normally open - normally closed

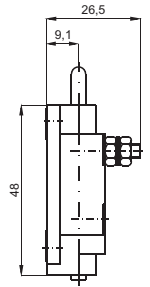

KLM...R switches plunger with roller

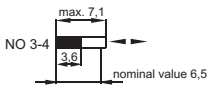
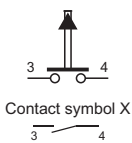
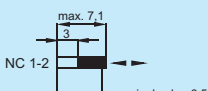
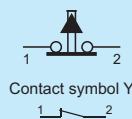
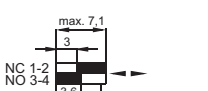
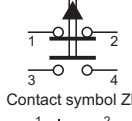
Cat. no.	Type	Operating diagram	Connection diagram	Description
36-1100	KLM1R			normally open
36-2100	KLM2R			normally closed
36-3100	KLM3R			normally open - normally closed

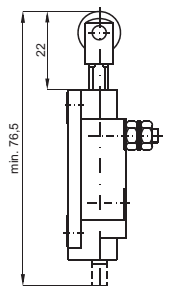

LIMIT SWITCHES

D type limit switches

D type limit switches are designed for use in signalling and protective circuits.

The limit switch is activated by a driving device. The force applied to the plunger lever switches the movable contacts. When the driving force ceases, the spring force causes movable contacts to return to the starting position.

The switch bodies are made of metal and plastic and have a ground terminal.

Conformity:

The switches are made in conformance with the IEC 60947-5-1 standard.

Technical drawings of limit switches in ".dwg" format are available at www.pokoj.com.pl in the section Offer, Design materials.

CLASSIFICATION AND MARKING

The switches are classified into three types on the basis of drive type:

- type **D-429** limit switches (a plunger with end is used),
- roller limit switches **429r** (plunger with roller and plunger clamping ring),
- Foot switches type **D-443** (the plunger is longer and ends with a knob, angle is used for fixing).

Technical data

TYPE	D
Conformity	IEC 60947-5-1
Use categories	AC-15, AC-13
Rated switching voltage Ue	AC: 400V DC: 48V
Rated switching currents Ie	AC: 2,5A DC: 2A
Nominal voltage of insulation Ui	500 V
Nominal impulse withstand voltage Uimp	2,5 kV
Switching overvoltage	< 2,5 kV
Protection class	IP40
Environmental pollution level	3
Type and highest values of rated data of the protective device used for preventing the effects of short-circuit currents	25A gG
Cut-off withstand current	6000A
Number of switching cycles	120h ⁻¹
Terminal cross-section	0,75...4mm ²
Change-over, double break-before-make contact with four terminals	type Zb
Min. driving force	25N
Installation altitude	below 2000 m above sea level
Ambient temperature	-25...+70 °C
Working position	any

D-429 switches

Cat. no.

37-0000

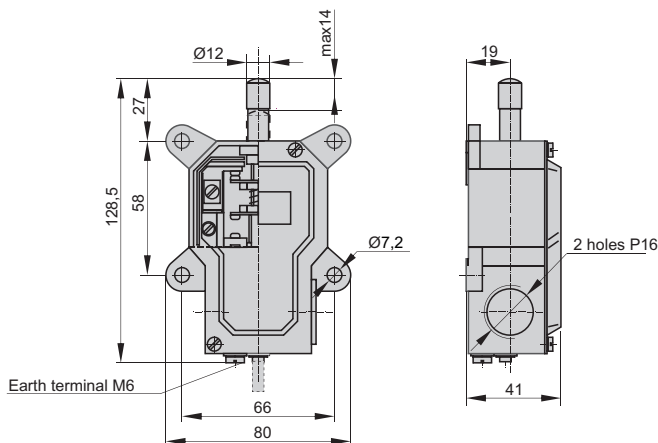

D-429r switches

Cat. no.

37-0100

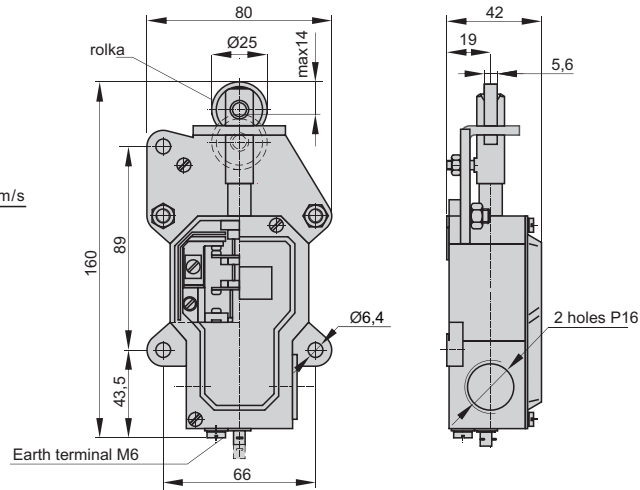
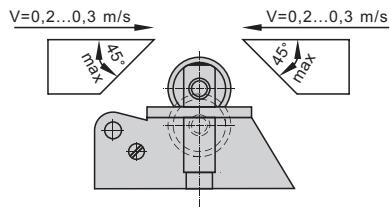

D-443 switches

Cat. no.

37-0200

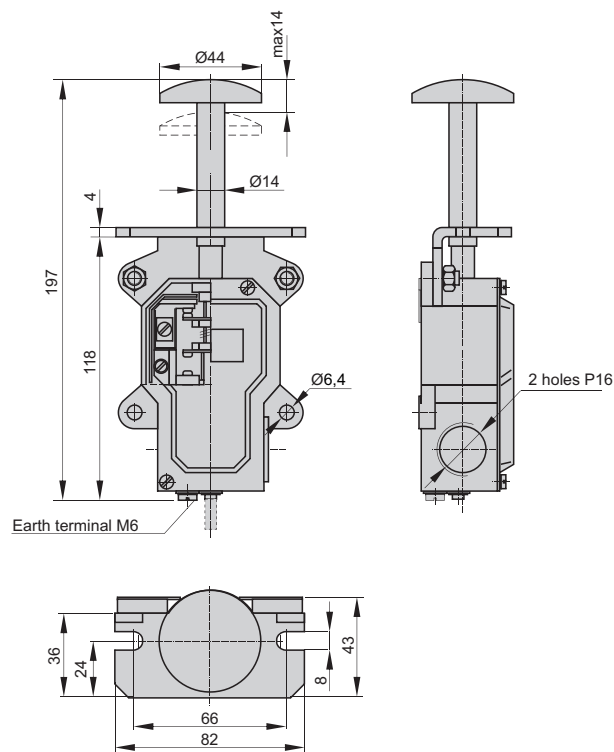

LIMIT SWITCHES

HOW TO READ OPERATING DIAGRAMS

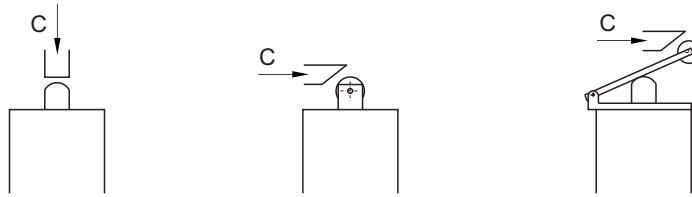

Operating diagram for a switch with snap action contact

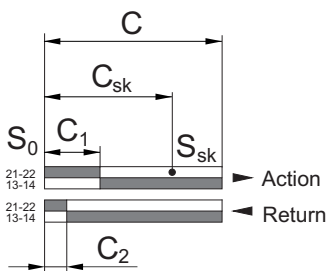

Operating diagram for a switch with slow contact

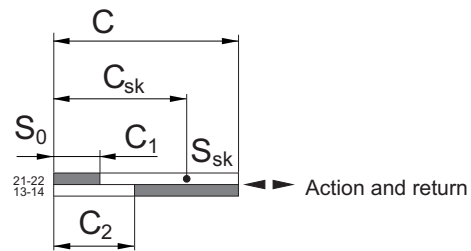

C_1 - distance of the driving element from point 0 to the start of switching of contacts

C_2 - the distance of the driving element from switching the contacts to the point S_0

C_{sk} - the distance of the driving element from S_0 to the efficient opening point

C - maximum distance of the driving element

S_{sk} - efficient opening point

S_0 - starting point - switch in a free state

SHORTENINGS USED IN THE DIAGRAMS

v_{max} - max. speed of the driving element

F_{sk} - min. force for the efficient opening

M_{sk} - min. torque for the efficient opening

F_{min} - minimum operating force

M_{min} - minimum operating torque

• - efficient opening

R - reset position

HEAD ADJUSTMENT

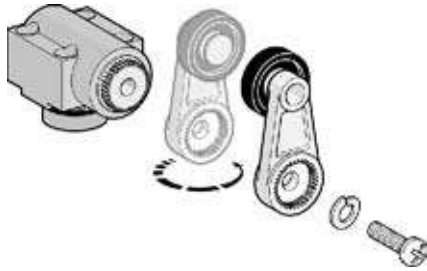

The plastic roller lever can be turned 180° in switch types PAP1, PDP1, PAM1, PDM1 and PEM.

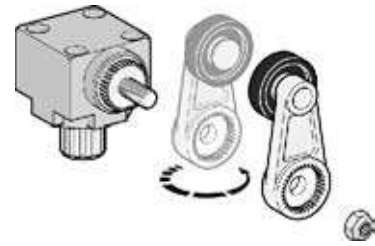

The plastic roller lever can be turned 180° in switch type PBM1.

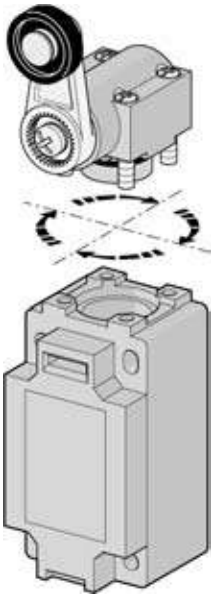

The head can be installed in 4 positions every 90° (for PEM - 2 positions every 180°).

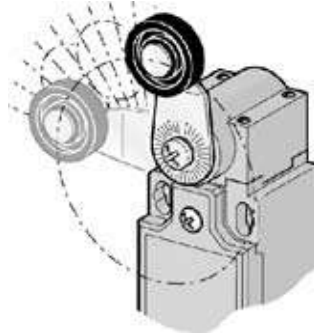

Free position of the lever in 10° steps for the switch types: PAP1, PDP1, PAM1, PDM1, PEM.

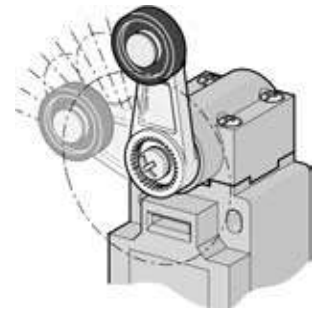

Free position of lever in 90° steps for switch type PBM1.

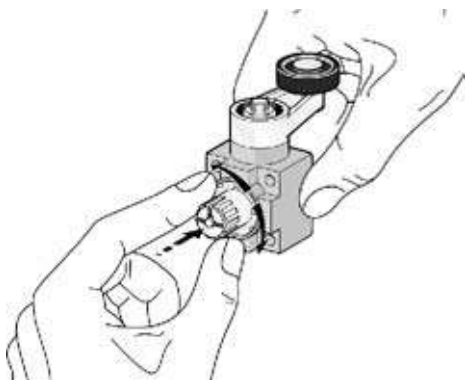

Selecting the lever operating mode for switches PBM1.



Two-way operation



Clockwise operation



Two-way operation

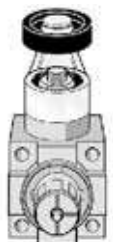

Counter clockwise operation

LIMIT SWITCHES

SAFETY PRECAUTIONS WHEN USING SWITCHES

Switches with plunger

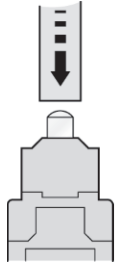

Correct operation

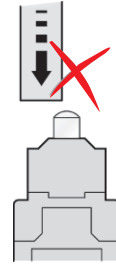

Incorrect operation

Switches with roller levers

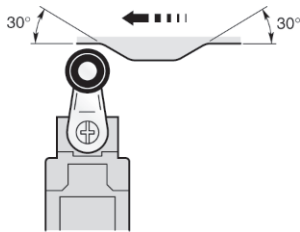

Correct operation

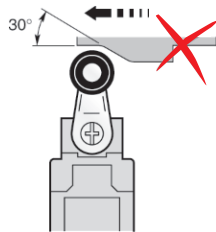

Incorrect operation

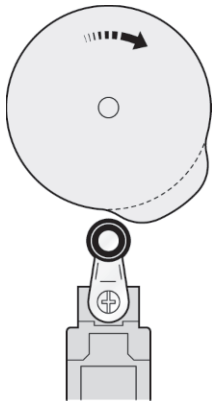
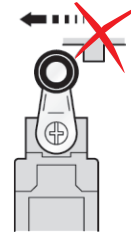

Correct operation

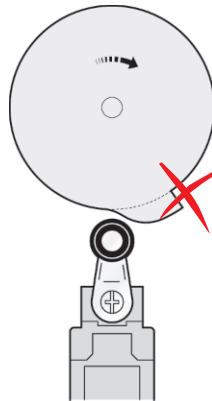

Incorrect operation

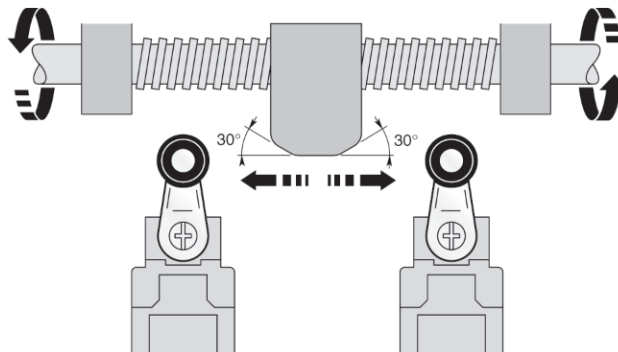
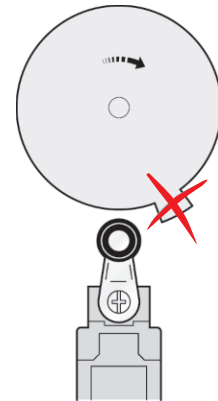

If the operation of switching element is slow, a limit switch with snap action contact is preferred PZ11, PZ02.

Выключатель концевой, путевой Минск т.80447584780

www.fotorele.net www.tiristor.by радиодетали, электронные компоненты

email minsk17@tut.by tel.+375 29 758 47 80 МТС

каталог, описание, технические, характеристики, datasheet, параметры, маркировка, габариты, фото, даташит,



QR код