

Magnecraft General Purpose Relays

Catalog
2014



■ Series Overview	3
■ 792 Control Series	4
■ 781 Series	9
■ 782 Power Series	13
■ 783 Series	17
■ 784 Series	21
■ 750 Series	25
■ 788 Series	29
■ 782H Hazardous Location Series	33
■ 750H Hazardous Location Series	37
■ UL Listed Relay/Socket Combinations	41
■ Sockets and Accessories	42
□ Socket Specifications	42
□ Mounting Adapter Specifications	65
□ Socket Accessories	66
■ Application Data	73
■ Website Guide	75

Series Overview

Magnecraft General Purpose Relays

Designed with specialized magnetic armatures and coils, Magnecraft General Purpose Relays easily handle current loads ranging from 10 mA to as large as 15 A. With multiple features, and a broad line of sockets and accessories, these relays offer the options needed to improve design, expedite installation and simplify testing of your application.

Key Features

- Socket, panel and DIN mounting options
- Multiple features and contact configurations available
- Optional protection, mounting, and identification accessories
- Ideal for MRO direct replacement
- UL Class I Division 2 models for hazardous locations

Series	Features	Terminals	Contact Configuration	Output Current	Page
 792 Control	Plug-In Relay	Blade	DPDT and 4PDT	3–12 A	4
 781	Plug-In Relay	Blade	SPDT	15 A	9
 782 Power	Plug-In Relay	Blade	DPDT	15 A	13
 783	Plug-In Relay	Blade	3PDT	15 A	17
 784	Plug-In Relay	Blade	4PDT	15 A	21
 750	Plug-In Relay	Octal (8 Pin)	DPDT	10 A	25
		Octal (11 Pin)	3PDT	10 A	
 788	Plug-In Relay	Blade	DPDT and 3PDT	10 A	29
 782H	Hermetically Sealed Relay	Blade	4PDT	5 A	33
				3 A	
				1 A	
 750H	Hermetically Sealed Relay	Octal (8 Pin)	DPDT	12 A	37
		Octal (11 Pin)	3PDT	12 A	

Description

Magnecraft General Purpose Relays

792 Control Series

DPDT 12 A; 4PDT 6 A and 3 A



UL listed when used with proper Magnecraft sockets



792 Clear Cover



792 Full-Feature Cover

Description

The 792 Plug-in Control relays offer clear or full-feature covers with multiple mounting options and accessories; 4PDT models save valuable space while adding increased functionality.

Feature	Benefit
12 A / 6 A / 3 A switching current	Ideal for various automation panels and controls
Clear or full-feature cover options	Full-feature covers include LED indicator and locking test button to facilitate maintenance and expedite commissioning
DPDT and 4PDT contact options	Simultaneously control 2 or 4 separate circuits
Socket mount option	Simplifies installation and maintenance while also allowing the use of protection modules, hold-down clips and other accessories
Gold-flashed contacts	Reduces contact oxidation and increases shelf life
Mechanical flag indicator	Standard feature that displays relay status during testing or operation without having to power the relay

Contact Rating	Contact Configuration	Nominal Coil Voltage	Coil Resistance (Ω)	Contacts	Part Number: Clear Cover	Part Number: Clear Cover with LED	Part Number: Full-Feature Cover
3 A	4PDT	12 Vac	44	Low Level Bifurcated	792XDX3C-12A	792XDX3CL-12A	792XDX3M4L-12A
		24 Vac	177		792XDX3C-24A	792XDX3CL-24A	792XDX3M4L-24A
		48 Vac	708		792XDX3C-48A	792XDX3CL-48A	792XDX3M4L-48A
		120 Vac	3630		792XDX3C-120A	792XDX3CL-120A	792XDX3M4L-120A
		240 Vac	17720		792XDX3C-240A	792XDX3CL-240A	792XDX3M4L-240A
		12 Vdc	160		792XDX3C-12D	792XDX3CL-12D	792XDX3M4L-12D
		24 Vdc	640		792XDX3C-24D	792XDX3CL-24D	792XDX3M4L-24D
		48 Vdc	2560		792XDX3C-48D	792XDX3CL-48D	792XDX3M4L-48D
		110 Vdc	13440		792XDX3C-110D	792XDX3CL-110D	792XDX3M4L-110D
		12 A	DPDT		12 Vac	44	Standard
24 Vac	177			792XBXC-24A	-	792XBXM4L-24A	
48 Vac	708			792XBXC-48A	-	792XBXM4L-48A	
120 Vac	3630			792XBXC-120A	-	792XBXM4L-120A	
240 Vac	17720			792XBXC-240A	-	792XBXM4L-240A	
12 Vdc	160			792XBXC-12D	-	792XBXM4L-12D	
24 Vdc	640			792XBXC-24D	-	792XBXM4L-24D	
48 Vdc	2560			792XBXC-48D	-	792XBXM4L-48D	
110 Vdc	13440			792XBXC-110D	-	792XBXM4L-110D	
6 A	4PDT			12 Vac	44	Standard	
		24 Vac	177	792XDXC-24A	792XDXCCL-24A		792DXM4L-24A
		48 Vac	708	792XDXC-48A	792XDXCCL-48A		792DXM4L-48A
		120 Vac	3630	792XDXC-120A	792XDXCCL-120A		792DXM4L-120A
		240 Vac	17720	792XDXC-240A	792XDXCCL-240A		792DXM4L-240A
		12 Vdc	160	792XDXC-12D	792XDXCCL-12D		792DXM4L-12D
		24 Vdc	640	792XDXC-24D	792XDXCCL-24D		792DXM4L-24D
		48 Vdc	2560	792XDXC-48D	792XDXCCL-48D		792DXM4L-48D
		110 Vdc	13440	792XDXC-110D	792XDXCCL-110D		792DXM4L-110D

Part Number Explanation

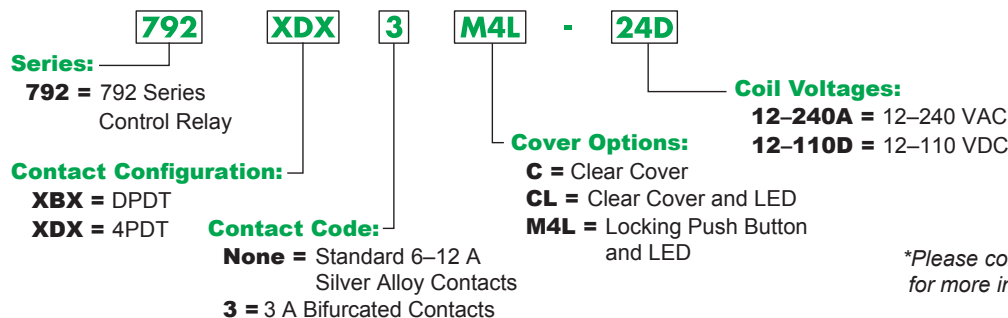

Specifications

Magnecraft General Purpose Relays

792 Control Series

DPDT 12 A; 4PDT 6 A and 3 A

Specifications

Part Number	792XBX
Contact Characteristics	
Terminal Style	Blade
Contact Material	Silver Alloy
Contact Configuration	DPDT
Maximum Switching Current	12 A
Maximum Switching Voltage	IEC: 250 Vac / 28 Vdc UL/CSA: 300 Vac / 30 Vdc
Rated Operational Current (Conforming to IEC AC-1 and DC-1)	NO: 12 A at 250 Vac, NC: 6 A at 250 Vac NO: 12 A at 28 Vdc, NC: 6 A at 28 Vdc
Rated Operational Current (Conforming to UL)	Resistive: 12 A at 277 Vac, 100k cycles Resistive: 12 A at 120 Vac, 200k cycles Resistive: 12 A at 30 Vdc, 100k cycles Motor: 1/2 HP at 120 Vac, 6k cycles Motor: 1 HP at 277 Vac, 6k cycles B300 PILOT DUTY, 6k cycles
Minimum Switching Requirement	10 mA at 17 Vdc
Coil Characteristics	
Maximum Operating Voltage	110% (AC / DC)
Maximum Pickup Voltage	80% (AC); 80% (DC)
Drop-out Voltage Threshold	15% (AC); 10% (DC)
Average Consumption	0.9–1.2 VA (AC); 0.8–1.1 W (DC)
General Characteristics	
Electrical Life at Rated Load	200,000 operations (where stated)
Mechanical Life (Unpowered)	10,000,000 operations
Operating Time	25 ms max. at 80% rated coil voltage 20 ms max. at 100% rated coil voltage
Release time	20 ms max. (DC) 35 ms max. (AC)
Impulse Withstand Voltage	4 kV (1.2 / 50 μ s)
Dielectric Strength - Between Coil and Contact (AC)	2000 V(rms)
Dielectric Strength - Between Poles (AC)	2000 V(rms)
Dielectric Strength - Between Contacts (AC)	1300 V(rms)
Ambient Air Temperature around the Device - Storage	-40 to +85 °C (-40 to +185 °F)
Ambient Air Temperature around the Device - Operation	-40 to +55 °C (-40 to +131 °F)
Vibration Resistance - In Operation	3 g-n at 35–150 Hz
Vibration Resistance - Not Operating	5 g-n at 35–150 Hz
Shock Resistance - In Operation	10 g-n
Shock Resistance - Not Operating	30 g-n
Degree of Protection (Housing Only)	IP 40
Weight	37 g (1.31 oz)
Agency Approvals	UL with socket, UR (E164862), CE, CSA (225619), RoHS

Note: Actual product performance may vary depending on application and environmental conditions.

Specifications (continued)

Magnecraft General Purpose Relays

792 Control Series

DPDT 12 A; 4PDT 6 A and 3 A

Specifications (continued)

Part Number	792XDX	792XDX3
Contact Characteristics		
Terminal Style	Blade	Blade
Contact Material	Silver Alloy	Bifurcated
Contact Configuration	4PDT	4PDT
Maximum Switching Current	6 A	3 A
Load Type	Standard	Low Level
Maximum Switching Voltage	300 V	300 V
Rated Operational Current (Conforming to IEC AC1 and DC1)	NO: 6 A at 250 Vac, NC: 3 A at 250 Vac NO: 6 A at 28 Vdc, NC: 3 A at 28 Vdc	NO: 2 A at 250 Vac, NC: 1 A at 250 Vac NO: 2 A at 28 Vdc, NC: 1 A at 28 Vdc
Operational Current (Conforming to UL)	Resistive: 6 A at 277 Vac, 200k cycles Resistive: 8 A at 120 Vac, 200k cycles Resistive: 8 A at 30 Vdc, 200k cycles Motor: 1/3 HP at 120 Vac, 6k cycles Motor: 1/2 HP at 277 Vac, 6k cycles Pilot Duty: B300, 6k cycles	General Purpose: 3 A at 240–277 Vac General Purpose: 3 A at 120 Vac Resistive: 3 A at 30 Vdc Motor: 1/16 HP (2.8 A FLA) at 120 Vac Pilot Duty: 5 A make, 0.5 A break, 3 A continuous at 120 Vac
Minimum Switching Requirement	10 mA at 17 Vdc	3 mA at 5 Vdc
Coil Characteristics		
Maximum Operating Voltage	110% (AC / DC)	110% (AC / DC)
Maximum Pickup Voltage	80% (AC); 80% (DC)	80% (AC); 80% (DC)
Drop-out Voltage Threshold	15% (AC); 10% (DC)	15% (AC); 10% (DC)
Average Consumption	0.9–1.2 VA (AC); 0.8–1.1 W (DC)	0.9–1.2 VA (AC); 0.8–1.1 W (DC)
General Characteristics		
Electrical Life at Rated Load	200,000 operations (where stated)	100,000 (gen. purpose load) operations
Mechanical Life (Unpowered)	10,000,000 operations	10,000,000 operations
Operating Time	25 ms max. at 80% rated coil voltage 20 ms max. at 100% rated coil voltage	25 ms max. at 80% rated coil voltage 20 ms max. at 100% rated coil voltage
Release time	20 ms max. (DC) 35 ms max. (AC)	20 ms max. (DC) 35 ms max. (AC)
Impulse Withstand Voltage	2.5 kV (1.2 / 50 μs)	2.5 kV (1.2 / 50 μs)
Dielectric Strength - Between Coil and Contact (AC)	2000 V(rms)	2000 V(rms)
Dielectric Strength - Between Poles (AC)	1600 V(rms)	1600 V(rms)
Dielectric Strength - Between Contacts (AC)	1300 V(rms)	1300 V(rms)
Ambient Air Temperature around the Device - Storage	-40 to +85 °C (-40 to +185 °F)	-40 to +85 °C (-40 to +185 °F)
Ambient Air Temperature around the Device - Operation	-40 to +55 °C (-40 to +131 °F)	-40 to +55 °C (-40 to +131 °F)
Vibration Resistance - In Operation	3 g-n at 35–150 Hz	3 g-n at 35–150 Hz
Vibration Resistance - Not Operating	5 g-n at 35–150 Hz	5 g-n at 35–150 Hz
Shock Resistance - In Operation	10 g-n	10 g-n
Shock Resistance - Not Operating	30 g-n	30 g-n
Degree of Protection (Housing Only)	IP 40	IP 40
Weight	37 g (1.31 oz)	37 g (1.31 oz)
Agency Approvals	UL with socket, UR (E164862), CE, CSA (225619), RoHS	

Note: Actual product performance may vary depending on application and environmental conditions.

Dimensions, Wiring Diagrams

Magnecraft General Purpose Relays

792 Control Series

DPDT 12 A; 4PDT 6 A and 3 A

Dimensions — inches (millimeters)

Clear Cover Dimension

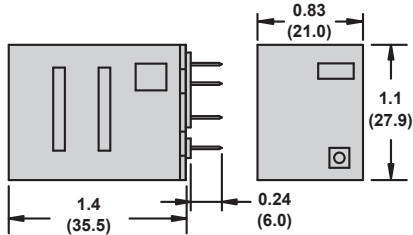

Full-Feature Cover Dimension

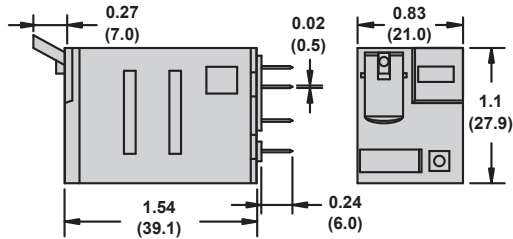

Wiring Diagrams

DPDT

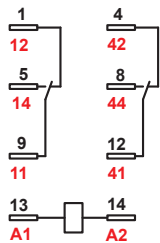

NEMA
IEC

4PDT

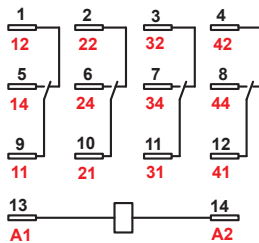

NEMA
IEC

Description

Magnecraft General Purpose Relays

792 Control Series Accessories

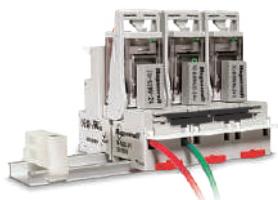

Description

Optional sockets offer customizable, Fingersafe™ solutions including protection modules, hold-down clips, and ID tags. Sockets are DIN rail and panel mount compatible.

Relay Accessories

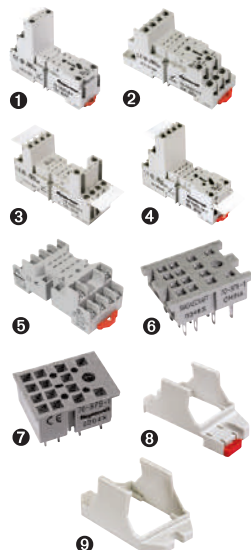

Description	Function	For Use With Relays	Pkg. Min.	Standard Part Number
Socket 1	DIN/Panel mount with elevator terminals	792XBX	10	70-782EL8-1
Socket 2	DIN/Panel mount with screw terminals and clamping plates	792XBX / 792XDX	10	70-782D14-1
Socket 3	DIN/Panel mount with rising elevator box terminals	792XBX / 792XDX	10	70-782E14-1
Socket 4	DIN/Panel mount with elevator terminals	792XBX / 792XDX	10	70-782EL14-1
Socket 5	DIN/Panel mount with screw terminals and clamping plates	792XDX	10	70-461-1
Socket 6	Solder terminals for chassis mount	792XDX	10	70-378-1
Socket 7	Printed circuit terminals for PCB mount	792XDX	10	70-379-1
Adapter 8	Mount directly to DIN rail	792XBX / 792XDX	10	16-782C
Adapter 9	Mount directly to panel	792XBX / 792XDX	10	16-782C1

Socket Accessories



Description	Function	For Use With Sockets	Coil Voltage	Pkg. Min.	Standard Part Number
Metal Spring Clip 1	Secures relay in socket	70-782D14-1, 70-782E14-1, 70-782EL14-1, 70-782EL8-1	–	10	16-782SC
Plastic Hold-Down Clip 2	Secures relay in socket or ejects relay off socket		–	10	16-782PC-1
Write-on tag 3	Small Write-on tag	–	–	10	16-782FT-1
Write-on tag 4	Write-on tag for 16-782PC-1 Hold-down Clip	–	–	10	16-700ST-1
Extruded Aluminum DIN Rail, 39.37" (1000 mm) 5	Quick installation and removal of sockets	70-782D14-1, 70-782E14-1, 70-782EL8-1, 70-782EL14-1	–	10	16-700DIN
DIN Rail End Clip 5	Holds sockets firmly in place on DIN rail	–	–	10	16-DCLIP-1
Insulated Coil Bus Jumper System 6	Wireless socket connection	70-782EL8-1, 70-782EL14-1	–	10	16-782CBJ-1
Small Socket Module	Protection Diode (Protects external drive circuitry from inductive voltages)	70-782D14-1, 70-782E14-1, 70-782EL14-1, 70-782EL8-1	6 to 250 Vdc	10	70-BSMD-250
Small Socket Module 7	LED Indicator (Provides coil status at a glance)		24 Vac/Vdc	10	70-BSMLG-24
Small Socket Module	MOV Suppressor (Protects from damaging electrical spikes)		120 Vac/Vdc	10	70-BSMM-120
			24 Vac/Vdc	10	70-BSMM-24
			240 Vac/Vdc	10	70-BSMM-240

Note: Use of LED socket module may increase coil power draw by up to 10%.

Description

Magnecraft General Purpose Relays

781 Series

SPDT 15 A



UL listed when used with proper Magnecraft sockets



781 Clear Cover



781 Full-Feature Cover

Description

The 781 Series plug-in relays offer clear or full-feature covers with multiple mounting options and accessories.

Feature	Benefit
15 A max. switching current	Ideal for automation control panels
14 mm width	Slim design saves valuable space
Clear or full-feature cover options	Full-feature covers include LED indicator and locking test button
Socket mount option	Simplifies installation and maintenance while also allowing the use of protection modules, hold-down clips and other accessories
Gold-flashed contacts	Reduces contact oxidation and increases shelf life
Mechanical flag indicator	Standard feature displays relay status during testing or operation

Contact Rating	Contact Configuration	Nominal Voltage	Coil Resistance (Ω)	Standard Part Number: Clear Cover	Standard Part Number: Clear Cover with LED	Standard Part Number: Full-Feature
15 A	SPDT	12 Vac 50/60Hz	44	781XAXRC-12A	781XAXRCL-12A	781XAXRM4L-12A
		24 Vac 50/60Hz	177	781XAXRC-24A	781XAXRCL-24A	781XAXRM4L-24A
		48 Vac 50/60Hz	708	781XAXRC-48A	781XAXRCL-48A	781XAXRM4L-48A
		120 Vac 50/60Hz	4430	781XAXRC-120A	781XAXRCL-120A	781XAXRM4L-120A
		240 Vac 50/60Hz	17720	781XAXRC-240A	781XAXRCL-240A	781XAXRM4L-240A
		12 Vdc	115	781XAXRC-12D	781XAXRCL-12D	781XAXRM4L-12D
		24 Vdc	450	781XAXRC-24D	781XAXRCL-24D	781XAXRM4L-24D
		48 Vdc	1800	781XAXRC-48D	781XAXRCL-48D	781XAXRM4L-48D
		110 Vdc	9460	781XAXRC-110D	781XAXRCL-110D	781XAXRM4L-110D

Part Number Explanation

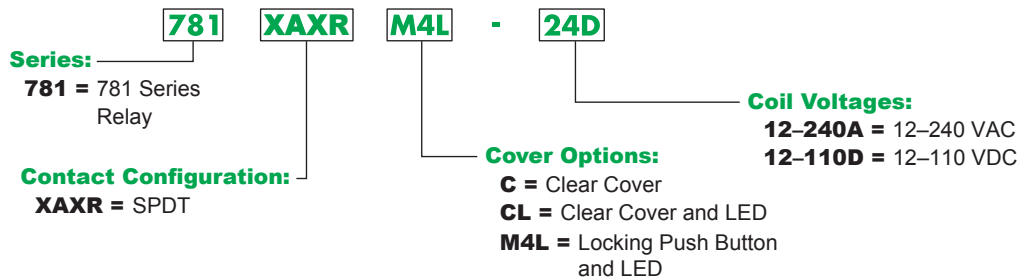

Please contact Customer Service for more information (847-441-2540).

Specifications

Magnecraft General Purpose Relays

781 Series

SPDT 15 A

Specifications

Part Number	781XAXR
Contact Characteristics	
Terminal Style	Blade
Contact Configuration	SPDT
Maximum Current	15 A
Contact Materials	Silver Alloy
Maximum Switching Voltage	IEC: 250 Vac / 28 Vdc UL/CSA: 300 Vac / 28 Vdc
Rated Switching Current at Voltage (Conforming to IEC AC-1 and DC-1)	NO: 15 A at 250 Vac, NC: 7.5 A at 250 Vac NO: 15 A at 28 Vdc, NC: 7.5 A at 28 Vdc
Rated Switching Current at Voltage (Conforming to UL)	Resistive: 15 A at 277 Vac 50 / 60 Hz, 100k cycles Resistive: 15 A at 28 Vdc, 100k cycles Motor: 1/2 HP at 120 Vac, 1k cycles Motor: 1 HP at 277 Vac, 1k cycles Pilot Duty: B300
Minimum Switching Requirement	100 mA at 5 Vdc
Coil Characteristics	
Maximum Operating Voltage	110% (AC / DC)
Maximum Pickup Voltage	85% (AC / DC)
Drop-out Voltage Threshold	15% (AC); 10% (DC)
Average Consumption	Standard: 1.6 VA (AC); 1.1 W (DC) With LED: 1.9 VA (AC); 1.4 W (DC)
General Characteristics	
Electrical Life at Rated Load	100,000 operations
Mechanical Life (Unpowered)	10,000,000 operations
Operating Time (Response Time)	20 ms
Dielectric Strength - Between Coil and Contact (AC)	2000 V(rms)
Dielectric Strength - Between Poles (AC)	2000 V(rms)
Dielectric Strength - Between Contacts (AC)	1500 V(rms)
Ambient Air Temperature around the Device - Storage	-40 to +85 °C (-40 to +185 °F)
Ambient Air Temperature around the Device - Operation	-40 to +55 °C (-40 to +131 °F)
Vibration Resistance - Operational	+/- 1 mm (10–35 Hz) and 3 g-n (35–150 Hz)
Shock Resistance	15 g-n
Degree of Protection (Housing Only)	IP 40
Weight	29 g (1.02 oz)
Agency Approvals	UL with socket, UR (E43641), CE, CSA (225619), RoHS

Note: Actual product performance may vary depending on application and environmental conditions.

Dimensions, Wiring Diagram

Magnecraft General Purpose Relays

781 Series

SPDT 15 A

Dimensions — inches (millimeters)

Clear Cover Dimensions

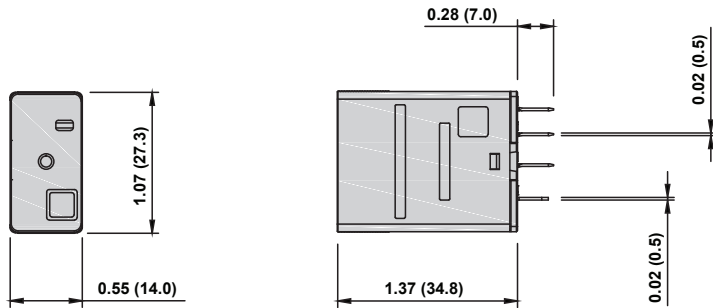

Full-Feature Cover Dimensions

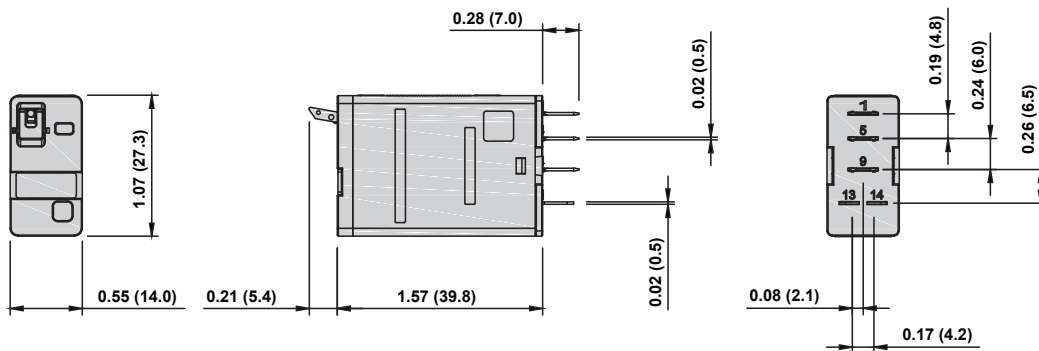

Wiring Diagram

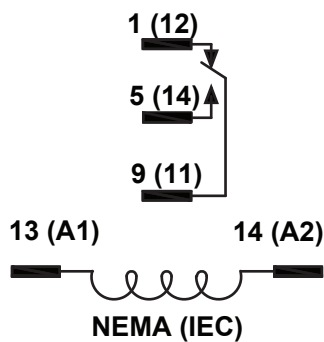

Description

Magnecraft General Purpose Relays

781 Series Accessories

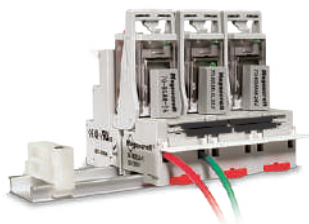

Description

Optional sockets offer customizable, Fingersafe solutions including protection modules, hold-down clips, and ID tags. Sockets are DIN rail and panel mount compatible.

Relay Accessories

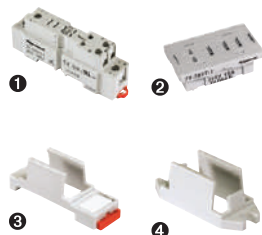

Description	Function	For Use With Relays	Pkg. Min.	Standard Part Number
Socket ①	DIN/Panel mount with screw terminals and clamping plates	781	10	70-781D5R-1A
Socket ②	PCB-mount socket		10	70-781T-1
Adapter ③	Mount directly to DIN rail		10	16-781C
Adapter ④	Mount directly to panel		10	16-781C1

Socket Accessories

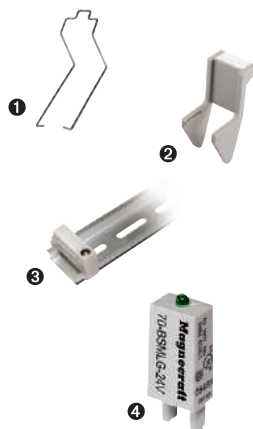

Description	Function	For Use With Sockets	Coil Voltage	Pkg. Min.	Standard Part Number
Metal Spring Clip ①	Secures relay in socket	70-781D5R-1A, 70-781T-1	–	10	16-781SC
Plastic ID Hold-Down Clip ②	Secures relay in socket and provides labeling	70-781D5R-1A	–	10	16-781IDC
Extruded Aluminum DIN Rail, 39.37" (1000 mm) ③	Quick installation and removal of sockets	70-781D5R-1A	–	10	16-700DIN
DIN Rail End Clip ③	Holds sockets firmly in place on DIN rail	–	–	10	16-DCLIP-1
Small Socket Module	Protection Diode (Protects external drive circuitry from inductive voltages)	70-781D5R-1A	6 to 250 Vdc	10	70-BSMD-250
Small Socket Module ④	LED Indicator (Provides coil status at a glance)		24 Vac/Vdc	10	70-BSMLG-24
Small Socket Module	MOV Suppressor (Protects from damaging electrical spikes)		120 Vac/Vdc	10	70-BSMM-120
			24 Vac/Vdc	10	70-BSMM-24
			240 Vac/Vdc	10	70-BSMM-240

Note: Use of LED socket module may increase coil power draw by up to 10%.

Description

Magnecraft General Purpose Relays

782 Power Series

DPDT 15 A



UL listed when used with proper Magnecraft sockets



782 Clear Cover



782 Full-Feature Cover

Description

The 782 Plug-in Power relays offer clear or full-feature covers with multiple mounting options and accessories.

Feature	Benefit
15 A switching current	Ideal for automation control panels
Clear or full-feature cover options	Full-feature covers include LED indicator and locking test button
Socket mount option	Simplifies installation and maintenance while also allowing the use of protection modules, hold-down clips and other accessories
Gold-flashed contacts	Reduces contact oxidation and increases shelf life
Mechanical flag indicator	Standard feature displays relay status during testing or operation

Contact Rating	Contact Configuration	Nominal Voltage	Coil Resistance (Ω)	Standard Part Number: Clear Cover	Standard Part Number: Clear Cover with LED	Standard Part Number: PC Mount	Standard Part Number: Full-Feature
15 A	DPDT	6 Vac 50/60Hz	11	–	–	782XBXCT-6A	–
		12 Vac 50/60Hz	44	782XBXC-12A	782XBXCL-12A	782XBXCT-12A	782XBXM4L-12A
		24 Vac 50/60Hz	177	782XBXC-24A	782XBXCL-24A	782XBXCT-24A	782XBXM4L-24A
		48 Vac 50/60Hz	708	782XBXC-48A	782XBXCL-48A	782XBXCT-48A	782XBXM4L-48A
		120 Vac 50/60Hz	4430	782XBXC-120A	782XBXCL-120A	782XBXCT-120A	782XBXM4L-120A
		240 Vac 50/60Hz	17720	782XBXC-240A	782XBXCL-240A	782XBXCT-240A	782XBXM4L-240A
		6 Vdc	40	–	–	782XBXCT-6D	–
		12 Vdc	160	782XBXC-12D	782XBXCL-12D	782XBXCT-12D	782XBXM4L-12D
		24 Vdc	640	782XBXC-24D	782XBXCL-24D	782XBXCT-24D	782XBXM4L-24D
		48 Vdc	2560	782XBXC-48D	782XBXCL-48D	782XBXCT-48D	782XBXM4L-48D
		110 Vdc	13440	782XBXC-110D	782XBXCL-110D	782XBXCT-110D	782XBXM4L-110D

Part Number Explanation

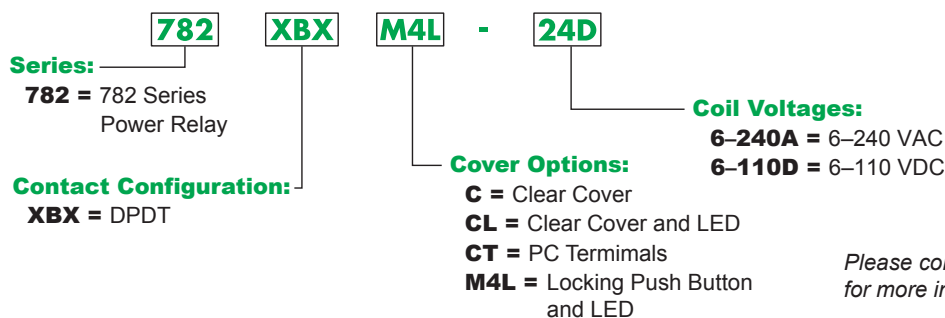

Specifications

Magnecraft General Purpose Relays

782 Power Series

DPDT 15 A

Specifications

Part Number	782XBXC / CL / M4L	782XBXT
Contact Characteristics		
Terminal Style	Blade	PC Terminals
Contact Configuration	DPDT	
Maximum Current	15 A	
Contact Materials	Silver Alloy	
Maximum Switching Voltage	IEC: 250 Vac / 28 Vdc UL/CSA: 300 Vac / 28 Vdc	
Rated Switching Current at Voltage (Conforming to IEC AC-1 and DC-1)	NO: 15 A at 250 Vac, NC: 7.5 A at 250 Vac NO: 15 A at 28 Vdc, NC: 7.5 A at 28 Vdc	
Rated Switching Current at Voltage (Conforming to UL)	Resistive: 15 A at 277 Vac 50 / 60 Hz, 100k cycles Resistive: 15 A at 28 Vdc, 100k cycles Motor: 1/2 HP at 120 Vac, 1k cycles Motor: 1 HP at 277 Vac, 1k cycles Pilot Duty: B300	
Minimum Switching Requirement	100 mA at 5 Vdc	
Coil Characteristics		
Maximum Operating Voltage	110% (AC / DC)	
Maximum Pickup Voltage	85% (AC); 80% (DC)	
Drop-out Voltage Threshold	15% (AC); 10% (DC)	
Average Consumption	Standard: 1.1 VA (AC); 0.85 W (DC) With LED: 1.4 VA (AC); 1.15 W (DC)	Standard: 1.1 VA (AC); 0.85 W (DC) With LED: 1.45 VA (AC); 1.2 W (DC)
General Characteristics		
Electrical Life at Rated Load	100,000 operations	
Mechanical Life (Unpowered)	10,000,000 operations	
Operating Time (Response Time)	20 ms	
Dielectric Strength - Between Coil and Contact (AC)	2000 V(rms)	
Dielectric Strength - Between Poles (AC)	2000 V(rms)	
Dielectric Strength - Between Contacts (AC)	1500 V(rms)	
Ambient Air Temperature around the Device - Storage	-40 to +85 °C (-40 to +185 °F)	
Ambient Air Temperature around the Device - Operation	-40 to +55 °C (-40 to +131 °F)	
Vibration Resistance - Operational	+/- 1 mm (10–35 Hz) and 3 g-n (35–150 Hz)	
Shock Resistance	15 g-n	
Degree of Protection (Housing Only)	IP 40	
Weight	36 g (1.27 oz)	
Agency Approvals	UL with socket, UR (E43641), CE, CSA (225619), RoHS	

Note: Actual product performance may vary depending on application and environmental conditions.

Dimensions, Wiring Diagrams

Magnecraft General Purpose Relays

782 Power Series

DPDT 15 A

Dimensions — inches (millimeters)

Clear Cover Dimensions

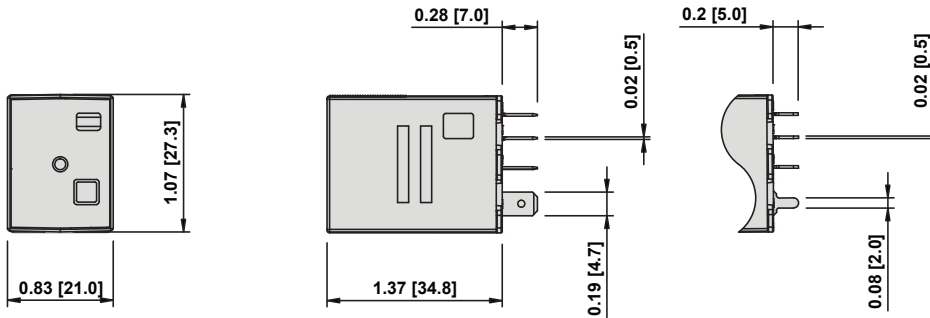

PC Terminals Dimensions

Full-Feature Cover Dimensions

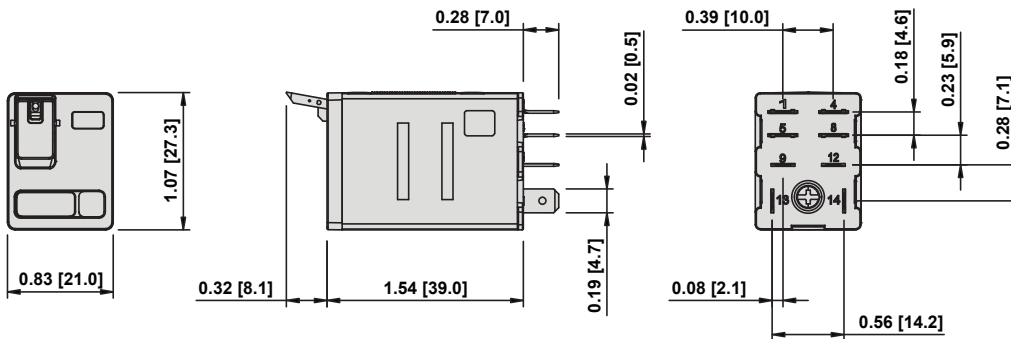

Wiring Diagram

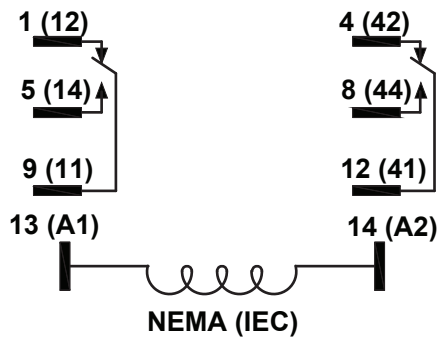

Description

Magnecraft General Purpose Relays

782 Power Series Accessories

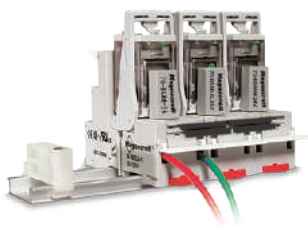

Description

Optional sockets offer customizable, Fingersafe solutions including protection modules, hold-down clips, and ID tags. Sockets are DIN rail and panel mount compatible.

Relay Accessories

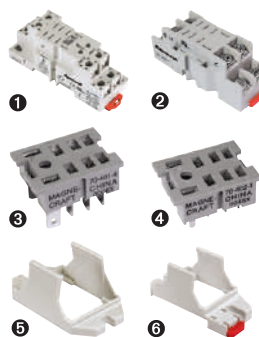

Description	Function	For Use With Relays	Pkg. Min.	Standard Part Number
Socket 1	DIN/Panel mount with screw terminals and clamping plates	782XBX	10	70-782D8-1A
Socket 2	DIN/Panel mount with screw terminals and clamping plates		10	70-459-1
Socket 3	Quick Connect terminals for chassis mount		10	70-401-1
Socket 4	Printed circuit terminals for PCB mount		10	70-402-1
Adapter 5	Mount directly to panel		10	16-782C1
Adapter 6	Mount directly to DIN rail		10	16-782C

Socket Accessories

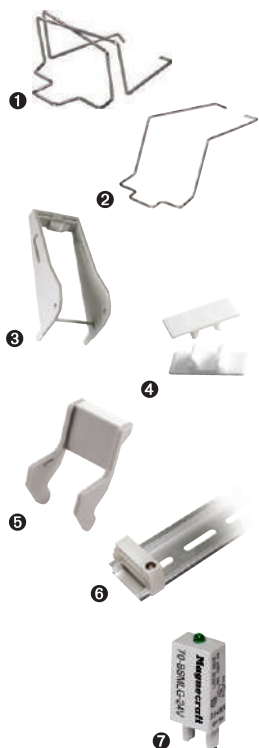

Description	Function	For Use With Sockets	Coil Voltage	Pkg. Min.	Standard Part Number
Metal Spring Clip 1 2	Secures relay in socket	70-782D8-1A, 70-459-1, 70-401-1, 70-402-1	–	10	16-1342
Plastic Hold-Down Clip 3	Secures relay in socket or ejects relay off socket	70-782D8-1A	–	10	16-782PC-1
Write-on tag 4	Write-on tag for 16-782PC-1 hold-down Clip	–	–	10	16-700ST-1
Plastic ID Hold-Down Clip 5	Secures relay in socket and provides labeling	70-782D8-1A, 70-459-1, 70-401-1, 70-402-1	–	10	16-782IDC
Extruded Aluminum DIN Rail, 39.37" (1000 mm) 6	Quick installation and removal of sockets	70-782D8-1A, 70-459-1	–	10	16-700DIN
DIN Rail End Clip 6	Holds sockets firmly in place on DIN rail	70-782D8-1A, 70-459-1	–	10	16-DCLIP-1
Small Socket Module	Protection Diode (Protects external drive circuitry from inductive voltages)	70-782D8-1A	6 to 250 Vdc	10	70-BSMD-250
Small Socket Module 7	LED Indicator (Provides coil status at a glance)		24 Vac/Vdc	10	70-BSMLG-24
Small Socket Module	MOV Suppressor (Protects from damaging electrical spikes)		120 Vac/Vdc	10	70-BSMM-120
			24 Vac/Vdc	10	70-BSMM-24
Small Socket Module			240 Vac/Vdc	10	70-BSMM-240

Note: Use of LED socket module may increase coil power draw by up to 10%.

Description

Magnecraft General Purpose Relays

783 Series

3PDT 15A



UL listed when used with proper Magnecraft sockets

Description

The 783 Series plug-in relays offer clear or full-feature covers with multiple mounting options and accessories.



783 Clear Cover

783 Full-Feature Cover

Feature	Benefit
15 A max. switching current	Ideal for automation panels and controls
Clear or full-feature cover options	Full-feature covers include LED indicator and locking test button
3PDT contact configuration	Simultaneously control up to 3 separate circuits
Socket mount option	Simplifies installation and maintenance while also allowing the use of protection modules, hold-down clips and other accessories
Gold-flashed contacts	Reduces contact oxidation and increases shelf life
Mechanical flag indicator	Standard feature displays relay status during testing or operation

Contact Rating	Contact Configuration	Nominal Voltage	Coil Resistance (Ω)	Standard Part Number: Clear Cover	Standard Part Number: Clear Cover with LED	Standard Part Number: Full-Feature
15 A	3PDT	12 Vac 50/60Hz	30	783XCXC-12A	783XCXCL-12A	783XCXM4L-12A
		24 Vac 50/60Hz	110	783XCXC-24A	783XCXCL-24A	783XCXM4L-24A
		48 Vac 50/60Hz	460	783XCXC-48A	783XCXCL-48A	783XCXM4L-48A
		120 Vac 50/60Hz	2880	783XCXC-120A	783XCXCL-120A	783XCXM4L-120A
		240 Vac 50/60Hz	11300	783XCXC-240A	783XCXCL-240A	783XCXM4L-240A
		12 Vdc	80	783XCXC-12D	783XCXCL-12D	783XCXM4L-12D
		24 Vdc	320	783XCXC-24D	783XCXCL-24D	783XCXM4L-24D
		48 Vdc	1280	783XCXC-48D	783XCXCL-48D	783XCXM4L-48D
		110 Vdc	6720	783XCXC-110D	783XCXCL-110D	783XCXM4L-110D

Part Number Explanation

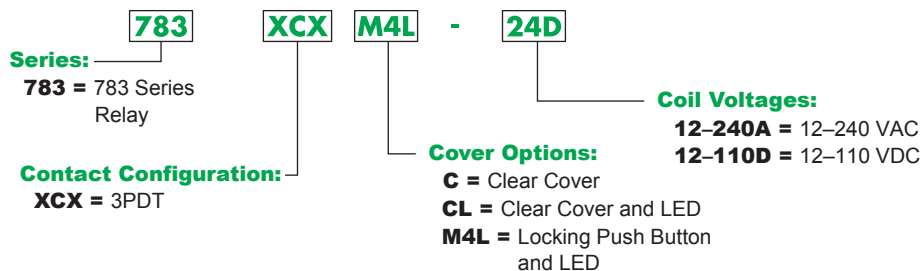

Please contact Customer Service for more information (847-441-2540).

Specifications

Magnecraft General Purpose Relays

783 Series

3PDT 15 A

Specifications

Part Number	783XCX
Contact Characteristics	
Terminal Style	Blade
Contact Configuration	3PDT
Maximum Current per Pole	15 A
Maximum Current for Product (all poles)	30 A up to 120 Vac, 28 Vdc total; 20 A from 150 Vac to 277 Vac total; 2 HP Maximum total
Contact Materials	Silver Alloy
Maximum Switching Voltage	IEC: 250 Vac / 28 Vdc UL/CSA: 300 Vac / 28 Vdc
Rated Switching Current at Voltage (Conforming to IEC AC-1 and DC-1)	NO: 15 A at 250 Vac, NC: 7.5 A at 250 Vac NO: 15 A at 28 Vdc, NC: 7.5 A at 28 Vdc
Rated Switching Current at Voltage (Conforming to UL)	Resistive: 15 A at 277 Vac 50 / 60 Hz, 100k cycles Resistive: 15 A at 28 Vdc, 100k cycles Motor: 1/2 HP at 120 Vac, 1k cycles Motor: 1 HP at 277 Vac, 1k cycles Pilot Duty: B300
Minimum Switching Requirement	100 mA at 5 Vdc
Coil Characteristics	
Maximum Operating Voltage	110% (AC / DC)
Maximum Pickup Voltage	85% (AC); 80% (DC)
Drop-out Voltage Threshold	15% (AC); 10% (DC)
Average Consumption	Standard: 1.7 VA (AC); 1.5 W (DC) With LED: 2.05 VA (AC); 1.85 W (DC)
General Characteristics	
Electrical Life at Rated Load	100,000 operations
Mechanical Life (Unpowered)	10,000,000 operations
Operating Time (Response Time)	20 ms
Dielectric Strength - Between Coil and Contact (AC)	2000 V(rms)
Dielectric Strength - Between Poles (AC)	2000 V(rms)
Dielectric Strength - Between Contacts (AC)	1500 V(rms)
Ambient Air Temperature around the Device - Storage	-40 to +85 °C (-40 to +185 °F)
Ambient Air Temperature around the Device - Operation	-40 to +55 °C (-40 to +131 °F)
Vibration Resistance - Operational	+/- 1 mm (10-35 Hz) and 3 g-n (35-150 Hz)
Shock Resistance	15 g-n
Degree of Protection (Housing Only)	IP 40
Weight	60 g (2.12 oz)
Agency Approvals	UL with socket, UR (E43641), CE, CSA (225619), RoHS

Note: Actual product performance may vary depending on application and environmental conditions.

Dimensions, Wiring Diagrams

Magnecraft General Purpose Relays

783 Series

3PDT 15 A

Dimensions — inches (millimeters)

Clear Cover Dimensions

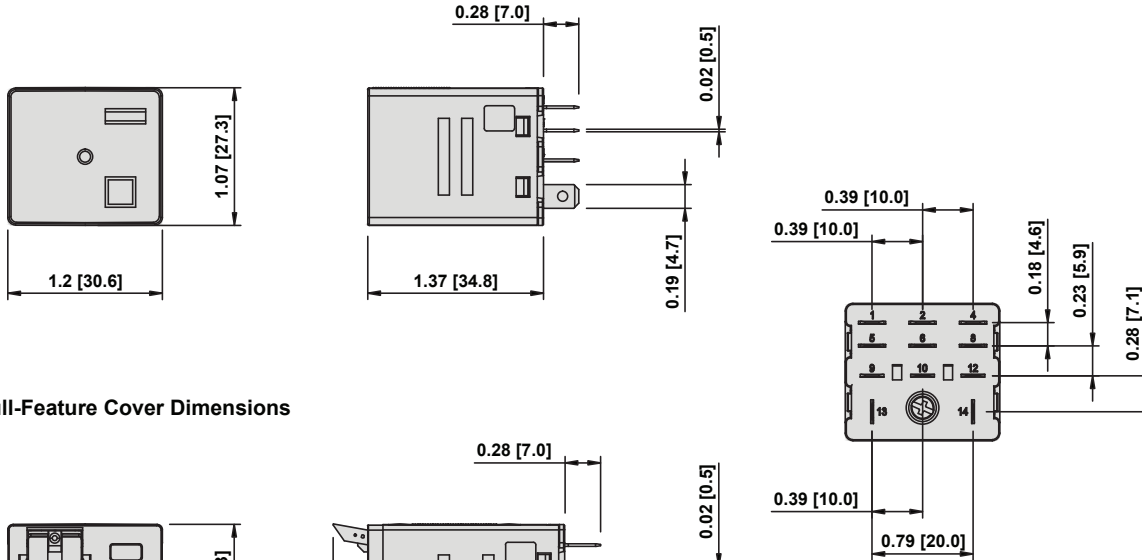

Full-Feature Cover Dimensions

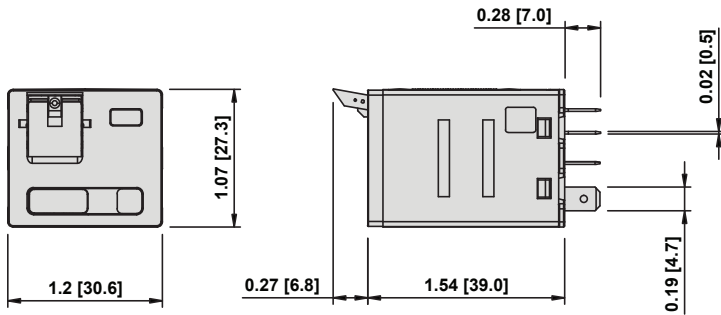

Wiring Diagram

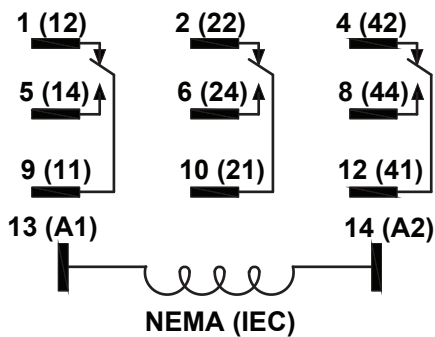

Description, Specifications

Magnecraft General Purpose Relays

783 Series Accessories

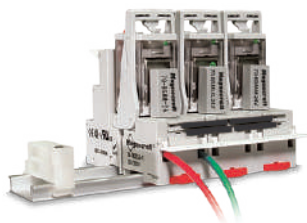

Description

Optional sockets offer customizable, Fingersafe solutions including protection modules, hold-down clips, and ID tags. Sockets are DIN rail and panel mount compatible.

Relay Accessories

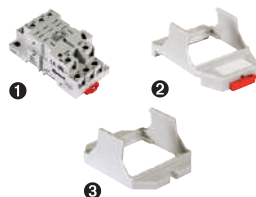

Description	Function	For Use With Relays	Pkg. Min.	Standard Part Number
Socket ①	Fingersafe, DIN/Panel mount with screw terminals and clamping plates	783	10	70-783D11-1A
Adapter ②	Mount directly to DIN rail		10	16-783C
Adapter ③	Mount directly to panel		10	16-783C1

Socket Accessories



Description	Function	For Use With Sockets	Coil Voltage	Pkg. Min.	Standard Part Number
Metal Spring Clip ①	Secures relay in socket	70-783D11-1A	–	10	16-783SC
Plastic ID Hold-Down Clip ②	Secures relay in socket and provides labeling		–	10	16-783IDC
Extruded Aluminum DIN Rail, 39.37" (1000 mm) ③	Quick installation and removal of sockets	–	–	10	16-700DIN
DIN Rail End Clip ③	Holds sockets firmly in place on DIN rail	–	–	10	16-DCLIP-1
Large Socket Module	MOV Suppressor (<i>Protects from damaging electrical spikes</i>)	70-783D11-1A	24 Vac/Vdc	10	70-ASMM-24
Large Socket Module	Protection Diode (<i>Protects external drive circuitry from inductive voltages</i>)		250 Vdc	10	70-ASMD-250
Large Socket Module ④	LED Indicator (<i>Provides coil status at a glance</i>)		110/240 Vac/Vdc	10	70-ASMLG-110/240
Large Socket Module	RC Suppressor (<i>Snubs back EMF of relay coil</i>)		110/240 Vac	10	70-ASMR-110/240

Note: Use of LED or RC socket module may increase coil power draw by up to 10%.

Description

Magnecraft General Purpose Relays

784 Series

4PDT 15 A



UL listed when used with proper Magnecraft sockets



784 Clear Cover



784 Full-Feature Cover

Description

The 784 Series plug-in relays offer clear or full-feature covers with multiple mounting options and accessories.

Feature	Benefit
15 A max. switching current	Ideal for automation panels and controls
Clear or full-feature cover options	Full-feature covers include LED indicator and locking test button
4PDT contact configuration	Simultaneously control up to 4 separate circuits
Socket mount option	Simplifies installation and maintenance while also allowing the use of protection modules, hold-down clips and other accessories
Gold-flashed contacts	Reduces contact oxidation and increases shelf life
Mechanical flag indicator	Standard feature displays relay status during testing or operation

Contact Rating	Contact Configuration	Nominal Voltage	Coil Resistance (Ω)	Standard Part Number: Clear Cover	Standard Part Number: Clear Cover with LED	Standard Part Number: Full-Feature
15 A	3PDT	12 Vac 50/60Hz	20	784DXC-12A	784DXCL-12A	784DXM4L-12A
		24 Vac 50/60Hz	80	784DXC-24A	784DXCL-24A	784DXM4L-24A
		48 Vac 50/60Hz	310	784DXC-48A	784DXCL-48A	784DXM4L-48A
		120 Vac 50/60Hz	2100	784DXC-120A	784DXCL-120A	784DXM4L-120A
		240 Vac 50/60Hz	8000	784DXC-240A	784DXCL-240A	784DXM4L-240A
		12 Vdc	76	784DXC-12D	784DXCL-12D	784DXM4L-12D
		24 Vdc	303	784DXC-24D	784DXCL-24D	784DXM4L-24D
		48 Vdc	1210	784DXC-48D	784DXCL-48D	784DXM4L-48D
		110 Vdc	6370	784DXC-110D	784DXCL-110D	784DXM4L-110D

Part Number Explanation

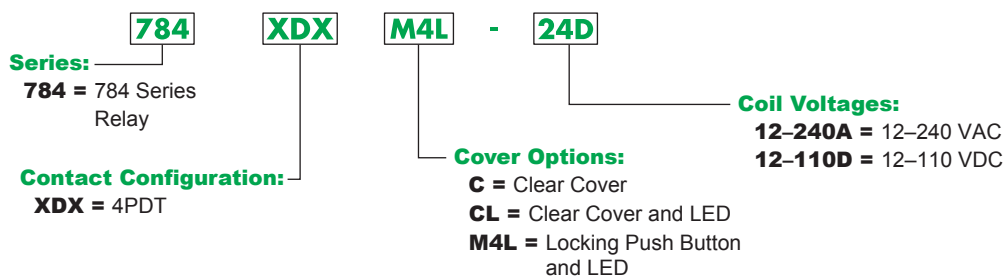

Please contact Customer Service for more information (847-441-2540).

Specifications

Magnecraft General Purpose Relays

784 Series

4PDT 15 A

Specifications

Part Number	784DX
Contact Characteristics	
Terminal Style	Blade
Contact Configuration	4PDT
Maximum Current per Pole	15 A
Maximum Current for Product (all poles)	30 A up to 120 Vac, 28 Vdc total; 20 A from 150 Vac to 277 Vac total; 2 HP Maximum total
Contact Materials	Silver Alloy
Maximum Switching Voltage	IEC: 250 Vac / 28 Vdc UL/CSA: 300 Vac / 28 Vdc
Rated Switching Current at Voltage (Conforming to IEC AC-1 and DC-1)	NO: 15 A at 250 Vac, NC: 7.5 A at 250 Vac NO: 15 A at 28 Vdc, NC: 7.5 A at 28 Vdc
Rated Switching Current at Voltage (Conforming to UL)	Resistive: 15 A at 277 Vac 50 / 60 Hz, 100k cycles Resistive: 15 A at 28 Vdc, 100k cycles Motor: 1/2 HP at 120 Vac, 1k cycles Motor: 1 HP at 277 Vac, 1k cycles Pilot Duty: B300
Minimum Switching Requirement	100 mA at 5 Vdc
Coil Characteristics	
Maximum Operating Voltage	110% (AC / DC)
Maximum Pickup Voltage	85% (AC); 80% (DC)
Drop-out Voltage Threshold	15% (AC); 10% (DC)
Average Consumption	Standard: 2.5 VA (AC); 1.6 W (DC) With LED: 2.85 VA (AC); 1.95 W (DC)
General Characteristics	
Electrical Life at Rated Load	100,000 operations
Mechanical Life (Unpowered)	10,000,000 operations
Operating Time (Response Time)	20 ms
Dielectric Strength - Between Coil and Contact (AC)	2000 V(rms)
Dielectric Strength - Between Poles (AC)	2000 V(rms)
Dielectric Strength - Between Contacts (AC)	1500 V(rms)
Ambient Air Temperature around the Device - Storage	-40 to +85 °C (-40 to +185 °F)
Ambient Air Temperature around the Device - Operation	-40 to +55 °C (-40 to +131 °F)
Vibration Resistance - Operational	+/- 1 mm (10–35 Hz) and 3 g-n (35–150 Hz)
Shock Resistance	15 g-n
Degree of Protection (Housing Only)	IP 40
Weight	80 g (2.82 oz)
Agency Approvals	UL with socket, UR (E43641), CE, CSA (225619), RoHS

Note: Actual product performance may vary depending on application and environmental conditions.

Dimensions, Wiring Diagrams

Magnecraft General Purpose Relays

784 Series

4PDT 15A

Dimensions — inches (millimeters)

Clear Cover Dimensions

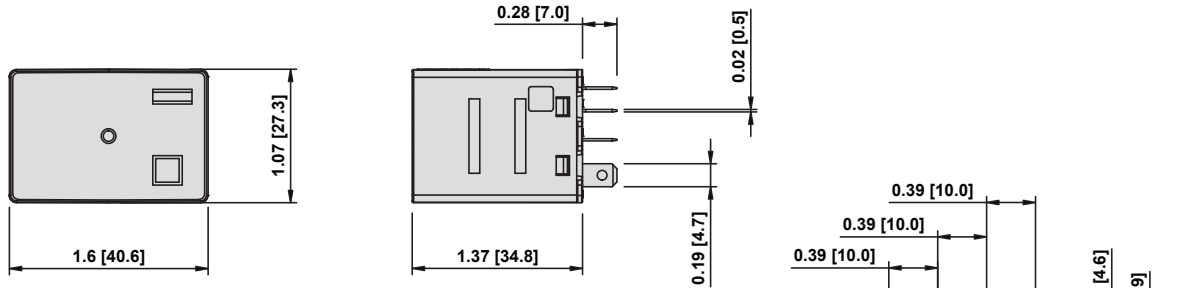

Full-Feature Cover Dimensions

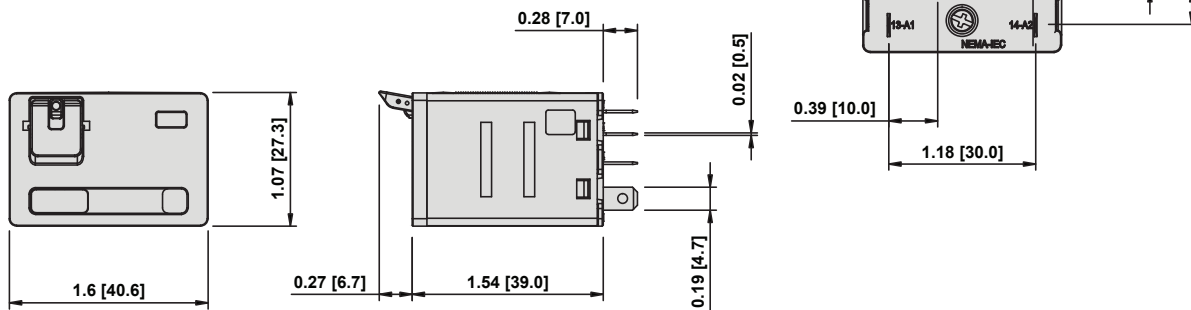

Wiring Diagram

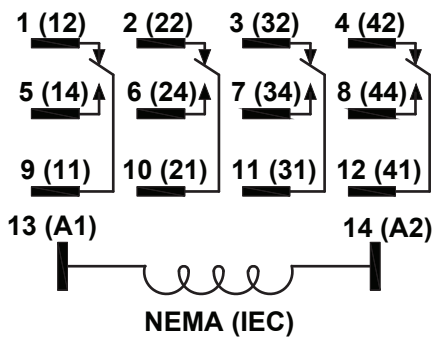

Description

Magnecraft General Purpose Relays

784 Series Accessories

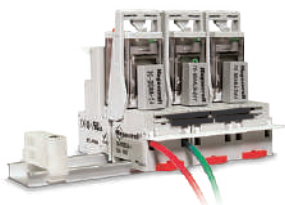

Description

Optional sockets offer customizable, Fingersafe solutions including protection modules, hold-down clips, and ID tags. Sockets are DIN rail and panel mount compatible.

Relay Accessories

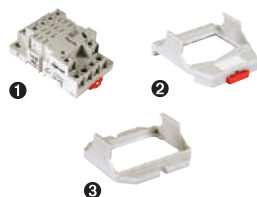

Description	Function	For Use With Relays	Pkg. Min.	Standard Part Number
Socket ①	Fingersafe, DIN/Panel mount with screw terminals and clamping plates	784	10	70-784D14-1
Adapter ②	DIN rail adapter	784	10	16-784C
Adapter ③	Flange mount adapter	784	10	16-784C1

Socket Accessories

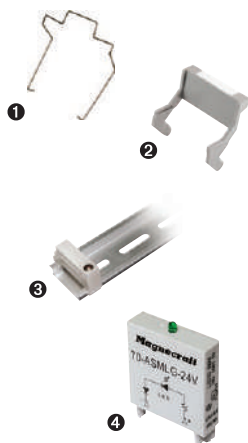

Description	Function	For Use With Socket	Coil Voltage	Pkg. Min.	Standard Part Number
Metal Spring Clip ①	Secures relay in socket	70-784D14-1	–	10	16-784SC
Plastic ID Hold-Down Clip ②	Secures relay in socket and provides labeling		–	10	16-784IDC
Extruded Aluminum DIN Rail, 39.37" (1000 mm) ③	Quick installation and removal of sockets	–	–	10	16-700DIN
DIN Rail End Clip ③	Holds sockets firmly in place on DIN rail	–	–	10	16-DCLIP-1
Large Socket Module	MOV Suppressor (<i>Protects from damaging electrical spikes</i>)	70-784D14-1	24 Vac/Vdc	10	70-ASMM-24
Large Socket Module	Protection Diode (<i>Protects external drive circuitry from inductive voltages</i>)		250 Vdc	10	70-ASMD-250
Large Socket Module ④	LED Indicator (<i>Provides coil status at a glance</i>)		110/240 Vac/Vdc	10	70-ASMLG-110/240
Large Socket Module	RC Suppressor (<i>Snubs back EMF of relay coil</i>)		110/240 Vac	10	70-ASMR-110/240

Note: Use of LED or RC socket module may increase coil power draw by up to 10%.

Description

Magnecraft General Purpose Relays

750 Series

DPDT and 3PDT, 10 A



UL listed when used with proper Magnecraft sockets



750 Clear Cover



750 Full-Feature Cover

Description

The 750 series octal base, plug-in relays offer clear or full-feature covers with multiple mounting options and accessories.

Feature	Benefit
Octal style mounting	Robust and historically-proven mounting platform that provides excellent structural support
10 A max. switching current	Ideal for automation panels and controls
Clear or full-feature cover options	Full-feature covers include LED indicator and locking test button
DPDT and 3PDT contact configurations	Simultaneously control separate circuits
Socket mount option	Simplifies installation and maintenance while also allowing the use of protection modules, hold-down clips and other accessories
Gold-flashed contacts	Reduces contact oxidation and increases shelf life
Mechanical flag indicator	Standard feature displays relay status during testing or operation

Contact Rating	Contact Configuration	Nominal Voltage	Coil Resistance (Ω)	Standard Part Number: Clear Cover	Standard Part Number: Clear Cover with LED	Standard Part Number: Full-Feature
10 A	DPDT	6 Vac 50/60Hz	3.9	750XBXRC-6A	750XBXRCL-6A	750XBXRM4L-6A
		12 Vac 50/60Hz	16.9	750XBXRC-12A	750XBXRCL-12A	750XBXRM4L-12A
		24 Vac 50/60Hz	72	750XBXRC-24A	750XBXRCL-24A	750XBXRM4L-24A
		48 Vac 50/60Hz	290	750XBXRC-48A	750XBXRCL-48A	750XBXRM4L-48A
		120 Vac 50/60Hz	1700	750XBXRC-120A	750XBXRCL-120A	750XBXRM4L-120A
		240 Vac 50/60Hz	6800	750XBXRC-240A	750XBXRCL-240A	750XBXRM4L-240A
		12 Vdc	120	750XBXRC-12D	750XBXRCL-12D	750XBXRM4L-12D
		24 Vdc	470	750XBXRC-24D	750XBXRCL-24D	750XBXRM4L-24D
		48 Vdc	1800	750XBXRC-48D	750XBXRCL-48D	750XBXRM4L-48D
	110 Vdc	7300	750XBXRC-110D	750XBXRCL-110D	750XBXRM4L-110D	
	3PDT	6 Vac 50/60Hz	3.9	750XCXRC-6A	750XCXRCL-6A	750XCXRM4L-6A
		12 Vac 50/60Hz	16.9	750XCXRC-12A	750XCXRCL-12A	750XCXRM4L-12A
		24 Vac 50/60Hz	72	750XCXRC-24A	750XCXRCL-24A	750XCXRM4L-24A
		48 Vac 50/60Hz	290	750XCXRC-48A	750XCXRCL-48A	750XCXRM4L-48A
		120 Vac 50/60Hz	1700	750XCXRC-120A	750XCXRCL-120A	750XCXRM4L-120A
		240 Vac 50/60Hz	6800	750XCXRC-240A	750XCXRCL-240A	750XCXRM4L-240A
		12 Vdc	120	750XCXRC-12D	750XCXRCL-12D	750XCXRM4L-12D
		24 Vdc	470	750XCXRC-24D	750XCXRCL-24D	750XCXRM4L-24D
48 Vdc		1800	750XCXRC-48D	750XCXRCL-48D	750XCXRM4L-48D	
110 Vdc	7300	750XCXRC-110D	750XCXRCL-110D	750XCXRM4L-110D		

Part Number Explanation

Series: **750** = 750 Series Relay
Contact Configuration: **XBXR** = DPDT
XCXR = 3PDT
Cover Options: **C** = Clear Cover
CL = Clear Cover and LED
M4L = Locking Push Button and LED
Coil Voltages: **6-240A** = 6-240 VAC
6-110D = 6-110 VDC

Please contact Customer Service for more information (847-441-2540).

Specifications

Magnecraft General Purpose Relays

750 Series

DPDT and 3DPT, 10 A

Specifications

Part Number	750XBXR	750XCXR
Contact Characteristics		
Terminal Style	Octal	Octal
Contact Configuration	DPDT	3PDT
Maximum Current	10 A	10 A
Contact Materials	Silver Alloy	Silver Alloy
Maximum Switching Voltage	IEC: 250 Vac / 28 Vdc UL/CSA: 300 Vac / 30 Vdc	IEC: 250 Vac / 28 Vdc UL/CSA: 300 Vac / 30 Vdc
Rated Switching Current at Voltage (Conforming to IEC AC-1 and DC-1)	NO: 10 A at 250 Vac, NC: 5 A at 250 Vac NO: 10 A at 28 Vdc, NC: 5 A at 28 Vdc	NO: 10 A at 250 Vac, NC: 5 A at 250 Vac NO: 10 A at 28 Vdc, NC: 5 A at 28 Vdc
Rated Switching Current at Voltage (Conforming to UL)	Resistive: 10 A at 277 Vac 50 / 60 Hz, 200k cycles Resistive: 10 A at 30 Vdc, 200k cycles Motor: 1/3 HP at 120 Vac, 6k cycles Motor: 1 HP at 277 Vac, 6k cycles Pilot Duty: B300, 6k cycles	Resistive: 10 A at 277 Vac 50 / 60 Hz, 200k cycles Resistive: 10 A at 30 Vdc, 200k cycles Motor: 1/3 HP at 120 Vac, 6k cycles Motor: 1 HP at 277 Vac, 6k cycles Pilot Duty: B300, 6k cycles
Minimum Switching Requirement	10 mA at 17 Vdc	10 mA at 17 Vdc
Coil Characteristics		
Maximum Operating Voltage	110% (AC / DC)	110% (AC / DC)
Maximum Pickup Voltage	85% (AC); 80% (DC)	85% (AC); 80% (DC)
Drop-out Voltage Threshold	15% (AC); 10% (DC)	15% (AC); 10% (DC)
Average Consumption	3 VA (AC); 1.4 W (DC)	3 VA (AC); 1.4 W (DC)
General Characteristics		
Electrical Life at Rated Load	100,000 operations	100,000 operations
Mechanical Life	5,000,000 operations	5,000,000 operations
Operating Time (Response Time)	20 ms	20 ms
Dielectric Strength - Between Coil and Contact (AC)	2500 V(rms)	2500 V(rms)
Dielectric Strength - Between Poles (AC)	2000 V(rms)	2000 V(rms)
Dielectric Strength - Between Open Contacts (AC)	1500 V(rms)	1500 V(rms)
Ambient Air Temperature around the Device - Storage	-40 to +85 °C (-40 to +185°F)	-40 to +85 °C (-40 to +185°F)
Ambient Air Temperature around the Device - Operation	-40 to +55 °C (-40 to +131°F)	-40 to +55 °C (-40 to +131°F)
Vibration Resistance - Operational	+/- 1 mm (10–35 Hz) and 3 g-n (35–150 Hz)	+/- 1 mm (10–35 Hz) and 3 g-n (35–150 Hz)
Shock Resistance	10 g-n	10 g-n
Degree of Protection (Housing Only)	IP 40	IP 40
Weight	83 g (2.93 oz)	83 g (2.93 oz)
Agency Approvals	UL with socket, UR (E164862), CE, CSA (225619), RoHS	

Note: Actual product performance may vary depending on application and environmental conditions.

Dimensions, Wiring Diagram

Magnecraft General Purpose Relays

750 Series

DPDT and 3DPT, 10 A

Dimensions — inches (millimeters)

Clear Cover Dimensions

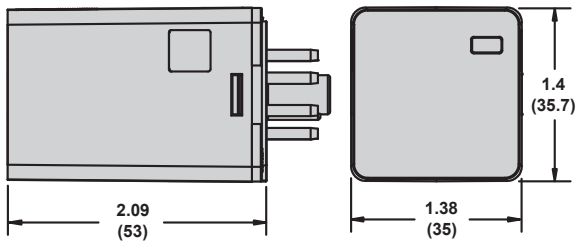

Full-Feature Cover Dimensions

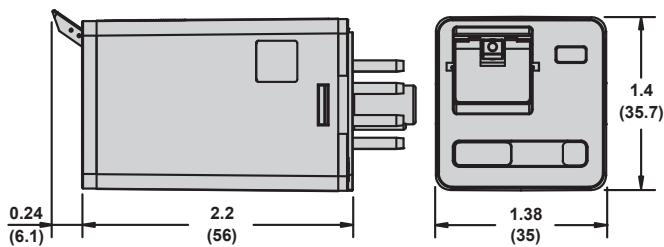

Wiring Diagrams

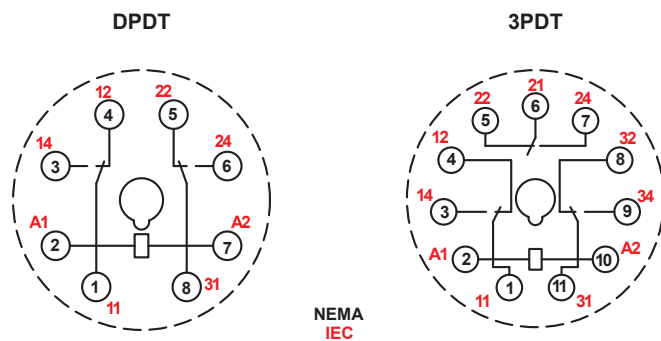

Description

Magnecraft General Purpose Relays

750 Series Accessories

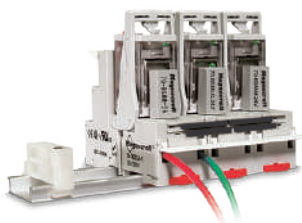

Description

Optional sockets offer customizable, Fingersafe solutions including protection modules, hold-down clips, and ID tags. Sockets are DIN rail and panel mount compatible.

Relay Accessories

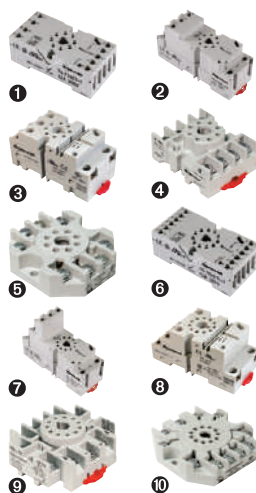

Description	Function	For Use With Relays	Pkg. Min.	Standard Part Number
Socket 1	DIN/Panel mount, module compatible	750XBXR	10	70-750E8-1
Socket 2	DIN/Panel mount with elevator terminals, module compatible	750XBXR	10	70-750EL8-1
Socket 3	DIN/Panel mount, module compatible	750XBXR	10	70-750DL8-1
Socket 4	DIN/Panel mount with screw terminals and clamping plates	750XBXR	10	70-464-1
Socket 5	Panel mount with screw terminals and clamping plates	750XBXR	10	70-169-1
Socket 6	DIN/Panel mount with elevator terminals, module compatible	750XCXR	10	70-750E11-1
Socket 7	DIN/Panel mount with elevator terminals	750XCXR	10	70-750EL11-1
Socket 8	DIN/Panel mount, module compatible	750XCXR	10	70-750DL11-1
Socket 9	DIN/Panel mount with screw terminals and clamping plates	750XCXR	10	70-465-1
Socket 10	Panel mount with screw terminals and clamping plates	750XCXR	10	70-170-1

Socket Accessories

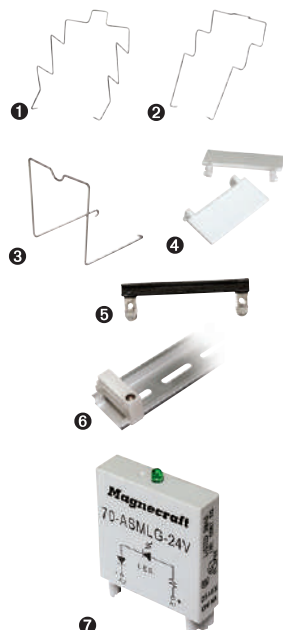

Description	Function	For Use With Sockets	Coil Voltage	Pkg. Min.	Standard Part Number
Metal Spring Clip 1	Secures relay in socket	70-750EL8-1, 70-750E8-1, 70-750E11-1, 70-464-1	–	10	16-1351
Metal Spring Clip 2	Secures relay in socket	70-750E8-1, 70-750DL8-1, 70-750E11-1, 70-464-1	–	10	16-1344
Metal Spring Clip 3	Secures relay in socket	70-750DL8-1	–	10	16-1332
Plastic I.D. Tag 4	Write-on plastic labels	70-750E8-1, 70-750EL8-1, 70-750DL8-1, 70-750E11-1, 70-750EL11, 70-750DL11-1	–	10	16-750/788FT-1
Insulated Coil Bus Jumper System 5	Wireless socket connection	70-750E8-1, 70-750EL8-1, 70-750DL8-1, 70-750E11-1, 70-464-1, 70-465-1	–	10	16-750/788CBJ-1
Extruded Aluminum DIN Rail, 39.37" (1000 mm) 6	Quick installation and removal of sockets	–	–	10	16-700DIN
DIN Rail End Clip 6	Plastic end clip with locking screw	–	–	10	16-DCLIP-1
Large Socket Module	MOV Suppressor (Protects from damaging electrical spikes)	70-750E8-1, 70-750EL8-1, 70-750DL8-1, 70-750E11-1, 70-750EL11-1, 70-750DL11-1	24 Vac/Vdc	10	70-ASMM-24
Large Socket Module	Protection Diode (Protects external drive circuitry from inductive voltages)	70-750E8-1, 70-750EL8-1, 70-750DL8-1, 70-750E11-1, 70-750EL11-1, 70-750DL11-1	250 Vdc	10	70-ASMD-250
Large Socket Module 7	LED Indicator (Provides coil status at a glance)	70-750E8-1, 70-750EL8-1, 70-750DL8-1, 70-750E11-1, 70-750EL11-1, 70-750DL11-1	110/240 Vac/Vdc	10	70-ASMLG-110/240
Large Socket Module	RC Suppressor (Snubs back EMF of relay coil)	70-750E8-1, 70-750EL8-1, 70-750DL8-1, 70-750E11-1, 70-750EL11-1, 70-750DL11-1	110/240 Vac	10	70-ASMR-110/240

Note: Use of LED or RC socket module may increase coil power draw by up to 10%.

Description

Magnecraft General Purpose Relays

788 Series

DPDT and 3PDT 10 A



UL listed when used with proper Magnecraft sockets



788 Clear Cover



788 Full-Feature Cover

Description

The 788 Series square base, plug-in relays offer clear, full-feature, top flange, and side flange covers as well as optional sockets and accessories.

Feature	Benefit
10 A max. switching current	Ideal for automation panels and controls
Clear or full-feature cover options	Full-feature covers include LED indicator and locking test button
DPDT and 3PDT contact configurations	Simultaneously control separate circuits
Socket mount option	Simplifies installation and maintenance while also allowing the use of protection modules, hold-down clips and other accessories
Gold-flashed contacts	Reduces contact oxidation and increases shelf life
Mechanical flag indicator	Standard feature displays relay status during testing or operation

Contact Rating	Contact Configuration	Nominal Voltage	Coil Resistance (Ω)	Standard Part Number: Clear Cover	Standard Part Number: Clear Cover with LED	Standard Part Number: Flange Mount	Standard Part Number: Full-Feature
10 A	DPDT	12 Vac 50/60Hz	16.9	788XBXRC-12A	788XBXRCL-12A	788XBXRC1-12A	788XBXRM4L-12A
		24 Vac 50/60Hz	72	788XBXRC-24A	788XBXRCL-24A	788XBXRC1-24A	788XBXRM4L-24A
		48 Vac 50/60Hz	290	788XBXRC-48A	788XBXRCL-48A	788XBXRC1-48A	788XBXRM4L-48A
		120 Vac 50/60Hz	1700	788XBXRC-120A	788XBXRCL-120A	788XBXRC1-120A	788XBXRM4L-120A
		240 Vac 50/60Hz	6800	788XBXRC-240A	788XBXRCL-240A	788XBXRC1-240A	788XBXRM4L-240A
		12 Vdc	120	788XBXRC-12D	788XBXRCL-12D	788XBXRC1-12D	788XBXRM4L-12D
		24 Vdc	470	788XBXRC-24D	788XBXRCL-24D	788XBXRC1-24D	788XBXRM4L-24D
	3PDT	48 Vdc	1800	788XBXRC-48D	788XBXRCL-48D	788XBXRC1-48D	788XBXRM4L-48D
		110 Vdc	7300	788XBXRC-110D	788XBXRCL-110D	788XBXRC1-110D	788XBXRM4L-110D
		12 Vac 50/60Hz	16.9	788XCXRC-12A	788XCXRCL-12A	788XCXRC1-12A	788XCXRM4L-12A
		24 Vac 50/60Hz	72	788XCXRC-24A	788XCXRCL-24A	788XCXRC1-24A	788XCXRM4L-24A
		48 Vac 50/60Hz	290	788XCXRC-48A	788XCXRCL-48A	788XCXRC1-48A	788XCXRM4L-48A
		120 Vac 50/60Hz	1700	788XCXRC-120A	788XCXRCL-120A	788XCXRC1-120A	788XCXRM4L-120A
		240 Vac 50/60Hz	6800	788XCXRC-240A	788XCXRCL-240A	788XCXRC1-240A	788XCXRM4L-240A
12 Vdc	120	788XCXRC-12D	788XCXRCL-12D	788XCXRC1-12D	788XCXRM4L-12D		
24 Vdc	470	788XCXRC-24D	788XCXRCL-24D	788XCXRC1-24D	788XCXRM4L-24D		
48 Vdc	1800	788XCXRC-48D	788XCXRCL-48D	788XCXRC1-48D	788XCXRM4L-48D		
110 Vdc	7300	788XCXRC-110D	788XCXRCL-110D	788XCXRC1-110D	788XCXRM4L-110D		

Note: Magnetic blowout versions are also available with an added contact rating of 3 A at 150 Vdc. Please refer to the Part Number Explanation shown below.

Part Number Explanation

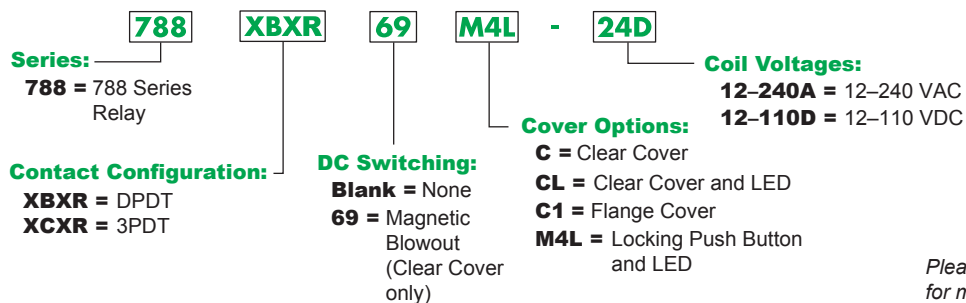

Please contact Customer Service for more information (847-441-2540).

Specifications

Magnecraft General Purpose Relays

788 Series

DPDT and 3PDT 10 A

Specifications

Part Number	788XBXR/XCXR
Contact Characteristics	
Terminal Style	Blade
Contact Configuration	DPDT/3PDT
Maximum Current	10 A
Contact Materials	Silver Alloy
Maximum Switching Voltage	IEC: 250 Vac / 28 Vdc UL/CSA: 300 Vac / 30 Vdc
Rated Switching Current at Voltage (Conforming to IEC AC-1 and DC-1)	NO: 10 A at 250 Vac, NC: 5 A at 250 Vac NO: 10 A at 28 Vdc, NC: 5 A at 28 Vdc
Rated Switching Current at Voltage (Conforming to UL)	Resistive: 10 A at 277 Vac 50 / 60 Hz, 200k cycles Resistive: 10 A at 30 Vdc, 200k cycles Motor: 1/3 HP at 120 Vac, 6k cycles Motor: 1 HP at 277 Vac, 6k cycles Pilot Duty: B300, 6k cycles
Rated Current with Magnetic Blowout (Code 69)	UL: 3 A at 150 Vdc (DPDT only), 6k cycles
Minimum Switching Requirement	10 mA at 17 Vdc
Coil Characteristics	
Maximum Operating Voltage	110% (AC / DC)
Maximum Pickup Voltage	85% (AC); 80% (DC)
Drop-out Voltage Threshold	15% (AC); 10% (DC)
Average Consumption	3 VA (AC); 1.4 W (DC)
General Characteristics	
Electrical Life at Rated Load	100,000 operations
Mechanical Life (Unpowered)	5,000,000 operations
Operating Time (Response Time)	20 ms
Dielectric Strength - Between Coil and Contact (AC)	2500 V(rms)
Dielectric Strength - Between Poles (AC)	2000 V(rms)
Dielectric Strength - Between Open Contacts (AC)	1500 V(rms)
Ambient Air Temperature around the Device - Storage	-40 to +85 °C (-40 to +185 °F)
Ambient Air Temperature around the Device - Operation	-40 to +55 °C (-40 to +131 °F)
Vibration Resistance - Operational	+/- 1 mm (10–35 Hz) and 3 g-n (35–150 Hz)
Shock Resistance	10 g-n
Degree of Protection (Housing Only)	IP 40
Weight	83 g (2.93 oz)
Agency Approvals	UL with socket, UR (E164862), CE, CSA (225619), RoHS

Note: Actual product performance may vary depending on application and environmental conditions.

Dimensions, Wiring Diagrams

Magnecraft General Purpose Relays

788 Series

DPDT and 3PDT 10 A

Dimensions — inches (millimeters)

Clear Cover Dimensions

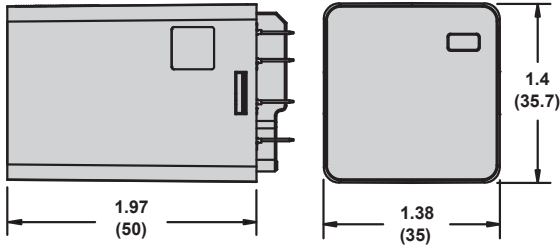

Full-Feature Cover Dimensions

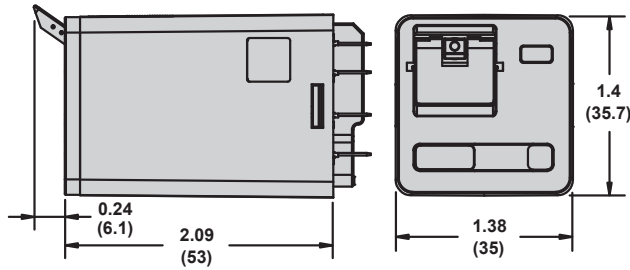

Side Flange Cover Dimensions

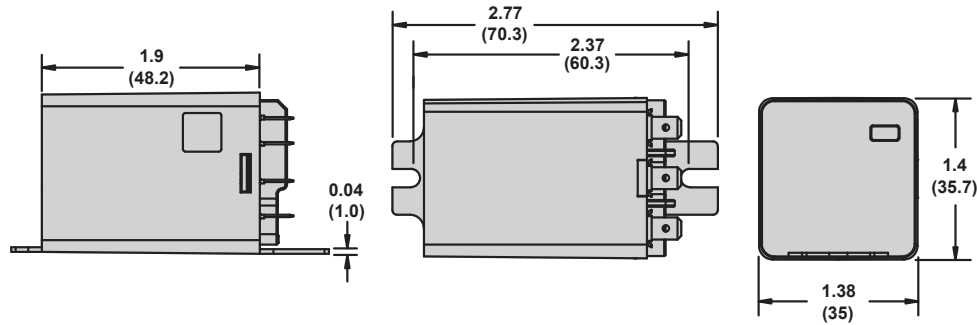

Wiring Diagrams

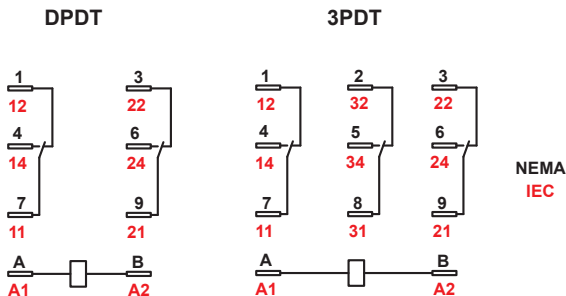

Description

Magnecraft General Purpose Relays

788 Series Accessories

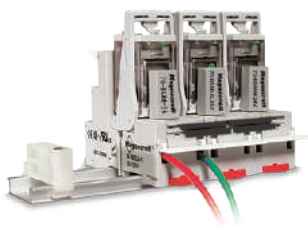

Description

Optional sockets offer customizable, Fingersafe solutions including protection modules, hold-down clips, and ID tags. Sockets are DIN rail and panel mount compatible.

Relay Accessories

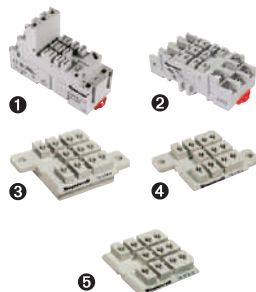

Description	Function	For Use With Relays	Pkg. Min.	Standard Part Number
Socket 1	DIN mount with elevator terminals	788XBXR/XCXR	10	70-788EL11-1
Socket 2	DIN/Panel mount with screw terminals and clamping plates		10	70-463-1
Socket 3	0.187 in. Quick Connect terminals with mounting tabs		10	70-124-2
Socket 4	Printed circuit terminals with mounting tabs		10	70-178-1
Socket 5	Printed circuit terminals without mounting tabs		10	70-178-2

Socket Accessories



Description	Function	For Use With Sockets	Coil Voltage	Pkg. Min.	Standard Part Number
Metal Spring Clip 1	Secures relay in socket	70-788EL11-1, 70-463-1, 70-124-1, 70-178-1, 70-178-2	–	10	16-1351
Metal Spring Clip 2	Secures relay in socket	70-463-1	–	10	16-1344
Insulated Coil Bus Jumper System 3	Wireless socket connection	70-788EL11-1	–	10	16-750/788CBJ-1
Plastic I.D. Tag 4	Write-on plastic labels	70-788EL11-1	–	10	16-750/788FT-1
Extruded Aluminum DIN Rail, 39.37" (1000 mm) 5	Quick installation and removal of sockets	70-788EL11-1, 70-463-1	–	10	16-700DIN
DIN Rail End Clip 5	Holds sockets firmly in place on DIN rail	–	–	10	16-DCLIP-1
Large Socket Module	MOV Suppressor (Protects from damaging electrical spikes)	70-788EL11-1	24 Vac/Vdc	10	70-ASMM-24
Large Socket Module	Protection Diode (Protects external drive circuitry from inductive voltages)		250 Vdc	10	70-ASMD-250
Large Socket Module 6	LED Indicator (Provides coil status at a glance)		110/240 Vac/Vdc	10	70-ASMLG-110/240
Large Socket Module	RC Suppressor (Snubs back EMF of relay coil)		110/240 Vac	10	70-ASMR-110/240

Note: Use of LED or RC socket module may increase coil power draw by up to 10%.

Description

Magnecraft General Purpose Relays

782H Hazardous Location Series

4PDT 3 A and 5 A



UL listed when used with proper Magnecraft sockets



782H Hazardous Location Relay

Description

The hermetically sealed 782H Series relays comply with UL Class I Division 2 requirements for use in hazardous locations.

Feature	Benefit
Hermetically sealed	Complies with UL Class I Division 2 for Hazardous Locations Groups A, B, C, and D; sealed for wash down conditions
3 A / 5 A max. switching current	Ideal for automation and control applications
4PDT contact configuration	Simultaneously control up to 4 separate circuits
Screw mount options	Allows for direct mounting
Socket mount option	Simplifies installation and maintenance while also allowing the use of protection modules, hold-down clips and other accessories
Gold-flashed contacts	Reduces contact oxidation and increases shelf life

Contact Rating	Contact Configuration	Nominal Voltage	Coil Resistance (Ω)	Standard Part Number
3 A	4PDT	120 Vac 50/60 Hz	3900	782DXH10-120A
		12 Vdc	160	782DXH10-12D
		24 Vdc	650	782DXH10-24D
		110 Vdc	11000	782DXH10-110D
5 A	4PDT	120 Vac 50/60 Hz	3900	782DXH21-120A
		12 Vdc	160	782DXH21-12D
		24 Vdc	650	782DXH21-24D

Part Number Explanation

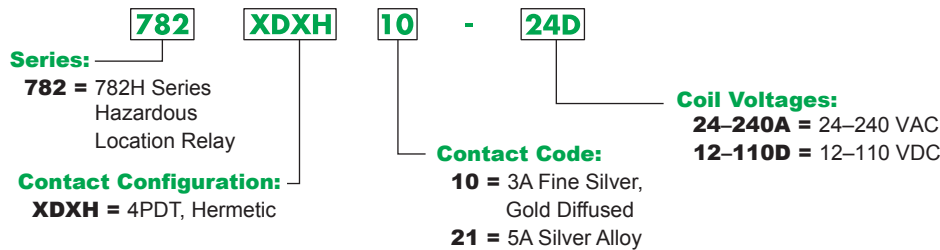

Please contact Customer Service for more information (847-441-2540).

Specifications

Magnecraft General Purpose Relays

782H Hazardous Location Series

4PDT 3 A and 5 A

Specifications

Part Number	782XDXH21	782XDXH10
Contact Characteristics		
Terminal Style	Blade	Blade
Contact Configuration	4PDT	4PDT
Maximum Current	5 A	3 A
Load Type	Standard	Low Level
Contact Materials	Silver Alloy	Fine Silver
Maximum Switching Voltage	300 V	300 V
Rated Switching Current at Voltage (Conforming to IEC AC-1)	5 A at 240 Vac (NO or NC Only)	3 A at 240 Vac (NO or NC Only)
Rated Switching Current at Voltage (Conforming to UL and ANSI/ISA 12.12.01)	Resistive: 5 A at 120 Vac 50 / 60 Hz, 100k cycles Resistive: 5 A at 240 Vac 50 / 60 Hz, 100k cycles Resistive: 15 A at 30 Vdc, 100k cycles	Resistive: 3 A at 120 Vac 50 / 60 Hz, 100k cycles Resistive: 3 A at 240 Vac 50 / 60 Hz, 100k cycles Resistive: 3 A at 30 Vdc, 100k cycles Motor: 1/10 HP at 120 Vac Motor: 1/10 HP at 240 Vac
Minimum Switching Requirement	100 mA at 5 Vdc	10 mA at 5 Vdc
Coil Characteristics		
Maximum Operating Voltage	110% (AC / DC)	110% (AC / DC)
Maximum Pickup Voltage	85% (AC); 80% (DC)	85% (AC); 80% (DC)
Drop-out Voltage Threshold	15% (AC); 10% (DC)	15% (AC); 10% (DC)
Average Consumption	1.2 VA (AC); 0.9 W (DC)	1.2 VA (AC); 0.9 W (DC)
General Characteristics		
Electrical Life at Rated Load	100,000 operations	100,000 operations
Mechanical Life (Unpowered)	10,000,000 operations	10,000,000 operations
Operating Time (Response Time)	20 ms	20 ms
Dielectric Strength - Between Coil and Contact (AC)	1240 V(rms)	1240 V(rms)
Dielectric Strength - Between Poles (AC)	1240 V(rms)	1240 V(rms)
Ambient Air Temperature around the Device - Storage	-40 to +85 °C (-40 to +185 °F)	-40 to +85 °C (-40 to +185 °F)
Ambient Air Temperature around the Device - Operation	-40 to +70 °C (-40 to +158 °F)	-40 to +70 °C (-40 to +158 °F)
Vibration Resistance - Operational	3 g-n at 10-55 Hz	3 g-n at 10-55 Hz
Shock Resistance	10 g-n	10 g-n
Degree of Protection	Hermetically Sealed	Hermetically Sealed
Weight	45 g (1.59 oz)	45 g (1.59 oz)
Agency Approvals	UL with socket, UR (E209950), CE, CSA (LR40787), RoHS	UL with socket, UR (E209950), CE, CSA (LR40787), RoHS

Note: Actual product performance may vary depending on application and environmental conditions.

Dimensions, Wiring Diagram

Magnecraft General Purpose Relays

782H Hazardous Location Series

4PDT 3 A and 5 A

Dimensions — inches (millimeters)

782H

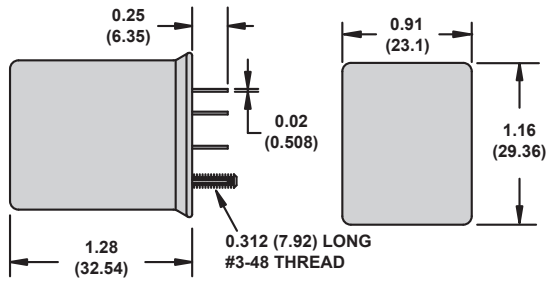

Wiring Diagrams

4PDT

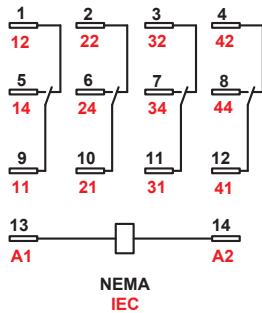

Description

Magnecraft General Purpose Relays

782H Hazardous Location Series Accessories

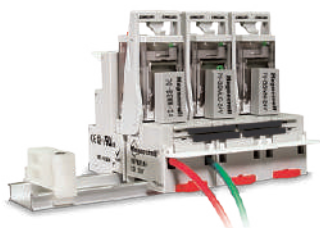

Description

Optional sockets offer customizable, Fingersafe solutions including protection modules, hold-down clips, and ID tags. Sockets are DIN rail and panel mount compatible.

Relay Accessories

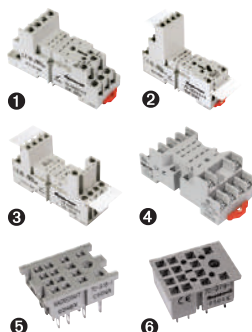

Description	Function	For Use With Relays	Pkg. Min.	Standard Part Number
Socket 1	DIN/Panel mount with screw terminals and clamping plates	782XDXH	10	70-782D14-1
Socket 2	DIN/Panel mount with elevator terminals	782XDXH	10	70-782EL14-1
Socket 3	DIN/Panel mount with rising elevator box terminals	782XDXH	10	70-782E14-1
Socket 4	DIN/Panel mount with screw terminals and clamping plates	782XDXH	10	70-461-1
Socket 5	Solder Terminals for Chassis Mount	782XDXH	10	70-378-1
Socket 6	Printed circuit terminals for PCB mount	782XDXH	10	70-379-1

Socket Accessories

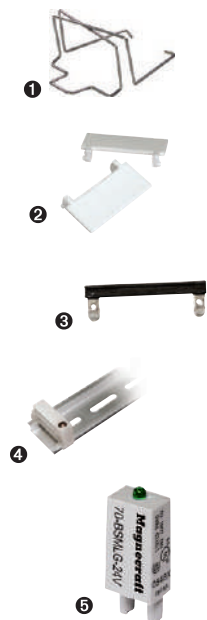

Description	Function	For Use With Sockets	Coil Voltage	Pkg. Min.	Standard Part Number
Metal Spring Clip 1	Secures relay in socket	70-782D14-1, 70-782E14-1, 70-782EL14-1, 70-461-1, 70-378-1, 70-379-1	–	10	16-1342
Plastic I.D. Tag 2	Write-on plastic labels	70-782E14-1, 70-782EL14-1	–	10	16-782FT-1
Insulated Coil Bus Jumper System 3	Wireless socket connection	70-782EL14-1	–	10	16-782CBJ-1
Extruded Aluminum DIN Rail, 39.37" (1000 mm) 4	Quick installation and removal of sockets	70-782D14-1, 70-782EL14-1, 70-782E14-1	–	10	16-700DIN
DIN Rail End Clip 4	Holds sockets firmly in place on DIN rail	–	–	10	16-DCLIP-1
Small Socket Module	Protection Diode (Protects external drive circuitry from inductive voltages)	70-782D14-1, 70-782EL14-1, 70-782E14-1	6 to 250 Vdc	10	70-BSMD-250
Small Socket Module 5	LED Indicator (Provides coil status at a glance)		24 Vac/Vdc	10	70-BSMLG-24
Small Socket Module	MOV Suppressor (Protects from damaging electrical spikes)		120 Vac/Vdc	10	70-BSMM-120
			24 Vac/Vdc	10	70-BSMM-24
			240 Vac/Vdc	10	70-BSMM-240

Note: Use of LED socket module may increase coil power draw by up to 10%.

Description

Magnecraft General Purpose Relays

750H Hazardous Location Series

DPDT, 3PDT 12 A



UL listed when used with proper Magnecraft sockets



750H Hazardous Location Relay

Description

The hermetically sealed 750H Series relays comply with UL Class I Division 2 requirements for use in hazardous locations.

Feature	Benefit
Hermetically sealed	Complies with UL Class I Division 2 for Hazardous Locations Groups A, B, C, and D; sealed for wash down conditions
Octal style mounting	Robust and historically-proven mounting platform that provides excellent structural support
12 A max. switching current	Ideal for automation and control applications
DPDT and 3PDT contact configuration	Simultaneously control separate circuits
Socket mount option	Simplifies installation and maintenance while also allowing the use of protection modules, hold-down clips and other accessories

Contact Rating	Contact Configuration	Nominal Voltage	Coil Resistance (Ω)	Standard Part Number
12 A	DPDT	24 Vac 50/60 Hz	72	750XBXH-24A
		120 Vac 50/60 Hz	1700	750XBXH-120A
		12 Vdc	120	750XBXH-12D
		24 Vdc	470	750XBXH-24D
		110 Vdc	10000	750XBXH-110D
	3PDT	24 Vac 50/60 Hz	72	750XCXH-24A
		120 Vac 50/60 Hz	1700	750XCXH-120A
		24 Vdc	470	750XCXH-24D
110 Vdc		10000	750XCXH-110D	

Part Number Explanation

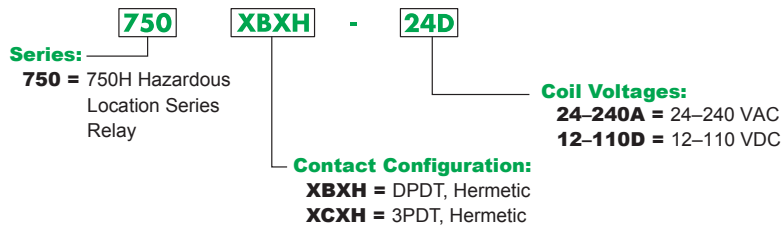

Please contact Customer Service for more information (847-441-2540).

Specifications

Magnecraft General Purpose Relays

750H Hazardous Location Series

DPDT, 3PDT 12 A

Specifications (UL 508)

Part Number	750VBXH	750VCXH
Contact Characteristics		
Terminal Style	Octal	Octal
Contact Configuration	DPDT	3PDT
Maximum Current	12 A	12 A
Load Type	Standard	Standard
Contact Materials	Silver Alloy	Silver Alloy
Maximum Switching Voltage	300 V	300 V
Rated Switching Current at Voltage (Conforming to UL and ANSI/ISA 12.12.01)	Resistive: 12 A at 120 Vac 50/60 Hz; 12 A at 240 Vac 50/60 Hz; 12 A at 28 Vdc Motor: 1/2 HP at 240 Vac 50/60 Hz; 1/3 HP at 120 Vac 50/60 Hz Pilot Duty: B300	Resistive: 12 A at 120 Vac 50/60 Hz; 12 A at 240 Vac 50/60 Hz; 12 A at 28 Vdc Motor: 1/2 HP at 240 Vac 50/60 Hz; 1/3 HP at 120 Vac 50/60 Hz Pilot Duty: B300
Minimum Switching Requirement	100 mA at 5 Vdc	100 mA at 5 Vdc
Coil Characteristics		
Maximum Operating Voltage	110% (AC / DC)	110% (AC / DC)
Maximum Pickup Voltage	85% (AC); 80% (DC)	85% (AC); 80% (DC)
Drop-out Voltage Threshold	15% (AC); 10% (DC)	15% (AC); 10% (DC)
Average Consumption	1.2 VA (AC); 0.9 W (DC)	2 VA (AC); 1.2 W (DC)
General Characteristics		
Electrical Life at Rated Load	100,000 operations	100,000 operations
Mechanical Life (Unpowered)	10,000,000 operations	10,000,000 operations
Operating Time (Response Time)	20 ms	20 ms
Dielectric Strength - Between Coil and Contact (AC)	1500 V(rms)	1500 V(rms)
Dielectric Strength - Between Poles (AC)	1500 V(rms)	1500 V(rms)
Ambient Air Temperature around the Device - Storage	-40 to +85 °C (-40 to 185 °F)	-40 to +85 °C (-40 to 185 °F)
Ambient Air Temperature around the Device - Operation	-40 to +55 °C (-40 to 131 °F)	-40 to +55 °C (-40 to 131 °F)
Vibration Resistance - Operational	3 g-n at 10-55 Hz	3 g-n at 10-55 Hz
Shock Resistance	10 g-n	10 g-n
Degree of Protection	Hermetically Sealed	Hermetically Sealed
Weight	130 g (4.59 oz)	130 g (4.59 oz)
Agency Approvals	UL with socket, UR (E209950), RoHS	UL with socket, UR (E209950), RoHS

Note: Actual product performance may vary depending on application and environmental conditions.

Dimensions, Wiring Diagrams

Magnecraft General Purpose Relays

750H Hazardous Location Series

DPDT, 3PDT 12 A

Dimensions — inches (millimeters)

750H

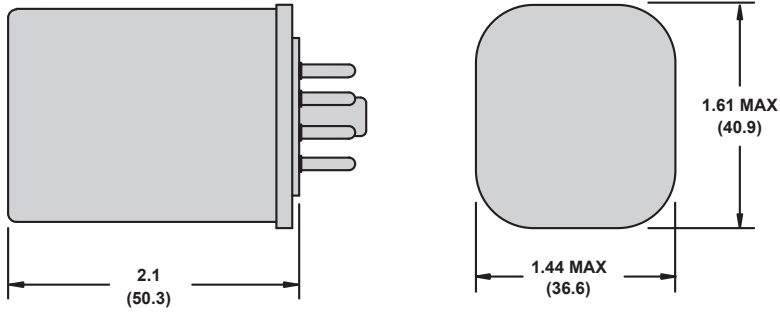

Wiring Diagrams

DPDT

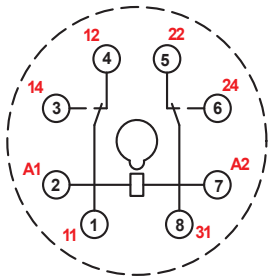

3PDT

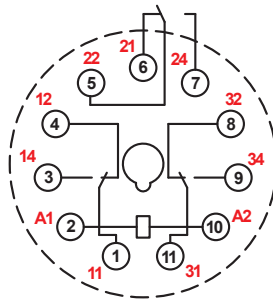

NEMA
IEC

Description

Magnecraft General Purpose Relays

750H Hazardous Location Series Accessories

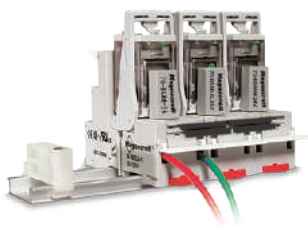

Description

Optional sockets offer customizable, Fingersafe solutions including protection modules, hold-down clips, and ID tags. Sockets are DIN rail and panel mount compatible.

Relay Accessories

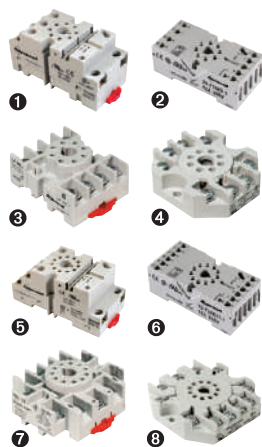

Description	Function	For Use With Relays	Pkg. Min.	Standard Part Number
Socket 1	DIN/Panel Mount with Screw Terminals	750XBXH	10	70-750DL8-1
Socket 2	DIN/Panel mount with elevator terminals, module compatible	750XBXH	10	70-750E8-1
Socket 3	DIN/Panel mount with screw terminals and clamping plates	750XBXH	10	70-464-1
Socket 4	Panel mount with screw terminals and clamping plates	750XBXH	10	70-169-1
Socket 5	DIN/Panel Mount	750XCXH	10	70-750DL11-1
Socket 6	DIN/Panel mount with elevator terminals	750XCXH	10	70-750E11-1
Socket 7	DIN/Panel mount with screw terminals and clamping plates	750XCXH	10	70-465-1
Socket 8	Panel mount with screw terminals and clamping plates	750XCXH	10	70-170-1

Socket Accessories



Description	Function	For Use With Sockets	Coil Voltage	Pkg. Min.	Standard Part Number
Metal Spring Clip 1	Secures relay in socket	70-750DL8-1, 70-750E8-1, 70-464-1, 70-750E11-1, 70-750DL11-1, 70-465-1	–	10	16-1351
Plastic I.D. Tag 2	Write-on plastic labels	70-750E8-1, 70-750E11-1	–	10	16-750/788FT-1
Insulated Coil Bus Jumper System 3	Wireless Socket Connection	70-750DL8-1, 70-750DL11-1	–	10	16-750/788CBJ-1
Extruded Aluminum DIN Rail, 39.37" (1000 mm) 4	Quick installation and removal of sockets	70-750DL8-1, 70-750E8-1, 70-464-1, 70-750E11-1, 70-750DL11-1, 70-465-1	–	10	16-700DIN
DIN Rail End Clip 4	Holds sockets firmly in place on DIN rail	–	–	10	16-DCLIP-1
Large Socket Module	MOV Suppressor (Protects from damaging electrical spikes)	70-750DL8-1, 70-750E8-1, 70-750E11-1, 70-750DL11-1	24 Vac/Vdc	10	70-ASMM-24
Large Socket Module	Protection Diode (Protects external drive circuitry from inductive voltages)		250 Vdc	10	70-ASMD-250
Large Socket Module 5	LED Indicator (Provides coil status at a glance)		110/240 Vac/Vdc	10	70-ASMLG-110/240
Large Socket Module	RC Suppressor (Snubs back EMF of relay coil)		110/240 Vac	10	70-ASMR-110/240

Note: Use of LED or RC socket module may increase coil power draw by up to 10%.

Contents

Magnecraft General Purpose Relays Sockets and Mounting Adapters

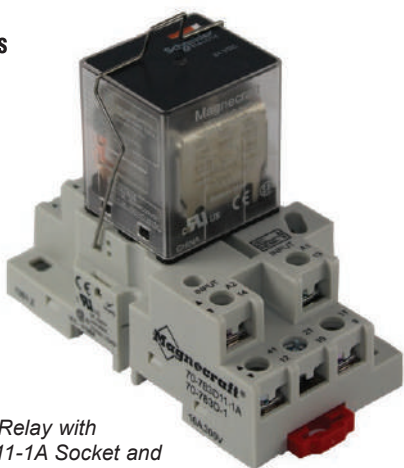

783XCX Relay with
70-783D11-1A Socket and
16-783SC Spring Clip

■ Socket Specifications42

■ Mounting Adapter Specifications65

The following relay/socket combinations comprise a UL Listed assembly when used with each other. This added benefit allows for easier installation as there are no end-use evaluations required when using Magnecraft relays or sockets with third party components.

UL Listed Relay/Socket Combinations

Mating Relay(s)	Number of Socket Pins	Socket Part Number	
781	5	70-781D5R-1A	
782	8	70-782D8-1A	
		70-459-1	
792XBX	8	70-782EL8-1	
792XDX	14	70-782D14-1	
		70-782E14-1	
		70-782EL14-1	
		70-461-1	
783	11	70-783D11-1A	
784	14	70-784D14-1	
		70-464-1	
		70-750E8-1	
		70-750EL8-1	
	8	70-750DL8-1	
		11	70-465-1
			70-750E11-1
			70-750EL11-1
70-750DL11-1			
788	11	70-463-1	
		70-788EL11-1	
782H	14	70-782EL14-1	
		70-782E14-1	
		70-782D14-1	
		70-461-1	
750H	8	70-464-1	
		70-750E8-1	
	11	70-465-1	
		70-750E11-1	

*Specifications,
Dimensions,
Wiring Diagrams*

Magnecraft General Purpose Relays
Socket Specifications
70-124-2

Socket Specifications

Part Number	70-124-2
Contact Configuration	3PDT
Number of Terminals	11
Mounting Style	Panel / Chassis
Current Rating	15 A
Nominal Voltage Rating	300 V
Storage Temperature Range	-40 to +105 °C (-40 to +221 °F)
Operating Temperature Range	-40 to +55 °C (-40 to +131 °F)
Protection Category (Fingersafe)	IP 20
Internal Metal Tracks	Copper Alloy, Zinc Plated
Screw Terminals	Copper Alloy, Zinc Plated
Screw Style	—
Screw Size	—
Maximum Screw Torque	—
Terminal Connection	Solder
Terminal Layout	Mix
Maximum Wire Size	Solid Cu: (Output) 16 AWG, 1.0 mm ² ; Stranded Cu: (Output) 16 AWG, 1.0 mm ²
DIN Rail Mounting, EN 60715	—
Chassis Mount Screw Torque	—
Flammability Rating	94V-0
Weight	12.1 g (0.43 oz)
Agency Approvals	UL (E70550), CE, CSA (LR40787), RoHS

Dimensions — inches (millimeters)

70-124-2

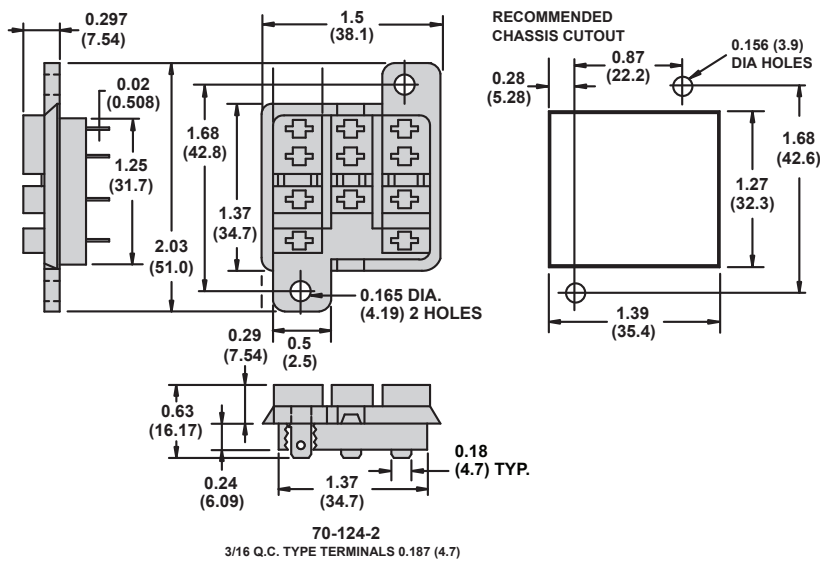

Wiring Diagram

70-124-2

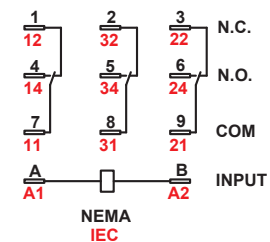

*Specifications,
Dimensions,
Wiring Diagrams*

Magnecraft General Purpose Relays
Socket Specifications
70-169-1 and 70-170-1

Socket Specifications

Part Number	70-169-1	70-170-1
Contact Configuration	DPDT	3PDT
Number of Terminals	8	11
Mounting Style	Panel	Panel
Current Rating	15 A	15 A
Nominal Voltage Rating	300 V	300 V
Storage Temperature Range	-40 to +105 °C (-40 to +221 °F)	-40 to +105 °C (-40 to +221 °F)
Operating Temperature Range	-40 to +55 °C (-40 to +131 °F)	-40 to +55 °C (-40 to +131 °F)
Protection Category (Fingersafe)	–	–
Internal Metal Tracks	Copper Alloy, Zinc Plated	Copper Alloy, Zinc Plated
Screw Terminals	Steel, Zinc Plated	Steel, Zinc Plated
Screw Style	Combination Head	Combination Head
Screw Size	M3.5 mm	M3.5 mm
Maximum Screw Torque	9 Lb-in / 1.0 N•m	9 Lb-in / 1.0 N•m
Terminal Connection	Screw Clamping	Screw Clamping
Terminal Layout	Mix	Mix
Maximum Wire Size	Solid Cu: 12/14 (2) AWG, 4/2.5 (2) mm ² Stranded Cu: 12/14 (2) AWG, 4/2.5 (2) mm ²	Solid Cu: 12/14 (2) AWG, 4/2.5 (2) mm ² Stranded Cu: 12/14 (2) AWG, 4/2.5 (2) mm ²
DIN Rail Mounting, EN 60715	35 mm	35 mm
Chassis Mount Screw Torque	7 Lb-in / 0.8 N•m	7 Lb-in / 0.8 N•m
Flammability Rating	94V-0	94V-0
Weight	57 g (2.01 oz)	57 g (2.01 oz)
Agency Approvals	UL (E70550), CE, CSA (LR97899), RoHS	UL (E70550), CE, CSA (LR97899), RoHS

Dimensions — inches (millimeters)

70-169-1

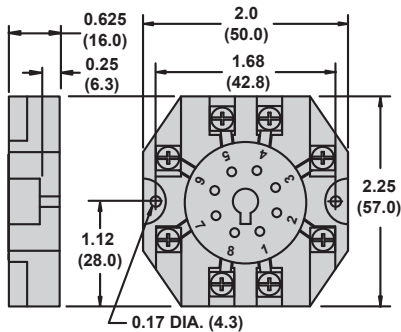

70-170-1

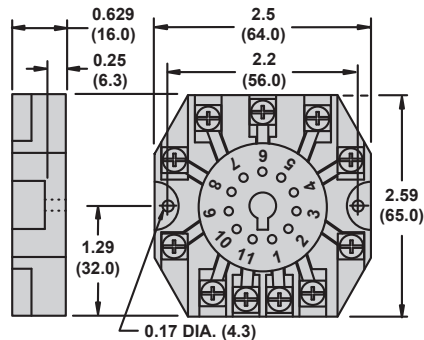

Wiring Diagrams

70-169-1

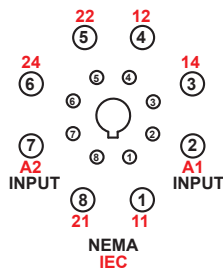

70-170-1

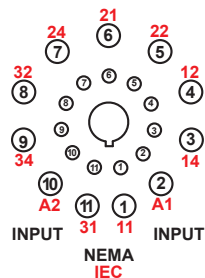

*Specifications,
Dimensions,
Wiring Diagrams*

Magnecraft General Purpose Relays

Socket Specifications

70-178-1 and 70-178-2

Socket Specifications

Part Number	70-178-1	70-178-2
Contact Configuration	3PDT	3PDT
Number of Terminals	11	11
Mounting Style	Panel / PCB	PCB
Current Rating	15 A	15 A
Nominal Voltage Rating	300 V	300 V
Storage Temperature Range	-40 to +105 °C (-40 to +221 °F)	-40 to +105 °C (-40 to +221 °F)
Operating Temperature Range	-40 to +55 °C (-40 to +131 °F)	-40 to +55 °C (-40 to +131 °F)
Protection Category (Fingersafe)	IP 20	IP 20
Internal Metal Tracks	Copper Alloy, Zinc Plated	Copper Alloy, Zinc Plated
Screw Terminals	Copper Alloy, Zinc Plated	Copper Alloy, Zinc Plated
Screw Style	—	—
Screw Size	—	—
Maximum Screw Torque	—	—
Terminal Connection	PCB	PCB
Terminal Layout	Mix	Mix
Maximum Wire Size	Solid Cu: (Output): 16 AWG, 1.0 mm ² Stranded Cu: (Output): 16 AWG, 1.0 mm ²	Solid Cu: (Output): 16 AWG, 1.0 mm ² Stranded Cu: (Output): 16 AWG, 1.0 mm ²
DIN Rail Mounting, EN 60715	—	—
Chassis Mount Screw Torque	—	—
Flammability Rating	94V-0	94V-0
Weight	12.1 g (0.43 oz)	12.1 g (0.43 oz)
Agency Approvals	UL (E70550), CE, CSA (LR40787), RoHS	UL (E70550), CE, CSA (LR40787), RoHS

Dimensions — inches (millimeters)

70-178-1

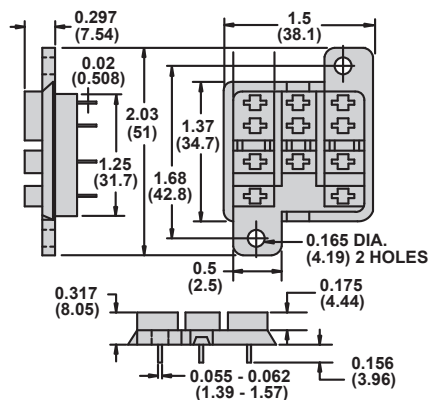

70-178-2

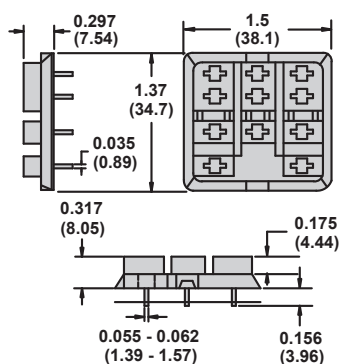

RECOMMENDED CIRCUIT BOARD LAYOUT FOR 70-178-1 & 70-178-2

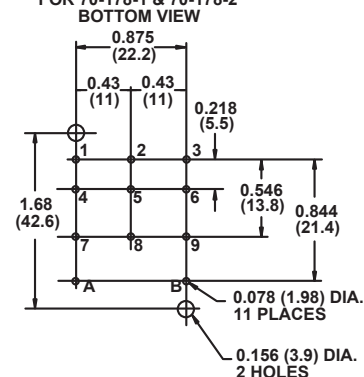

Wiring Diagram

70-178-1 & 70-178-2

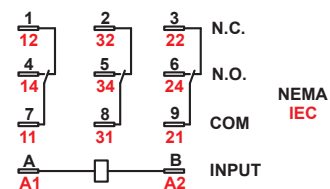

Specifications, Dimensions

Magnecraft General Purpose Relays

Socket Specifications

70-378-1 and 70-379-1

Socket Specifications

Part Number	70-378-1	70-379-1
Contact Configuration	4PDT	4PDT
Number of Terminals	14	14
Mounting Style	Chassis	PCB
Current Rating	5 A	5 A
Nominal Voltage Rating	120 V	120 V
Storage Temperature Range	-40 to +105 °C (-40 to +221 °F)	-40 to +105 °C (-40 to +221 °F)
Operating Temperature Range	-40 to +55 °C (-40 to +131 °F)	-40 to +55 °C (-40 to +131 °F)
Protection Category (Fingersafe)	–	–
Internal Metal Tracks	Copper Alloy, Zinc Plated	Copper Alloy, Zinc Plated
Screw Terminals	Copper Alloy, Zinc Plated	Copper Alloy, Zinc Plated
Screw Style	–	–
Screw Size	–	–
Maximum Screw Torque	–	–
Terminal Connection	Solder	PCB
Terminal Layout	Mix	Mix
Maximum Wire Size	Solid Cu: (Output): 18 AWG, 0.8 mm ² Stranded Cu: (Output): 18 AWG, 0.8 mm ²	–
DIN Rail Mounting, EN 60715	35 mm	–
Chassis Mount Screw Torque	7 Lb-in / 0.8 N·m	–
Flammability Rating	94V-0	94V-0
Weight	6.2 g (0.22 oz)	5.8 g (0.20 oz)
Agency Approvals	UL (E70550), CE, CSA (LR40787), RoHS	UL (E70550), CE, CSA (LR40787), RoHS

Dimensions — inches (millimeters)

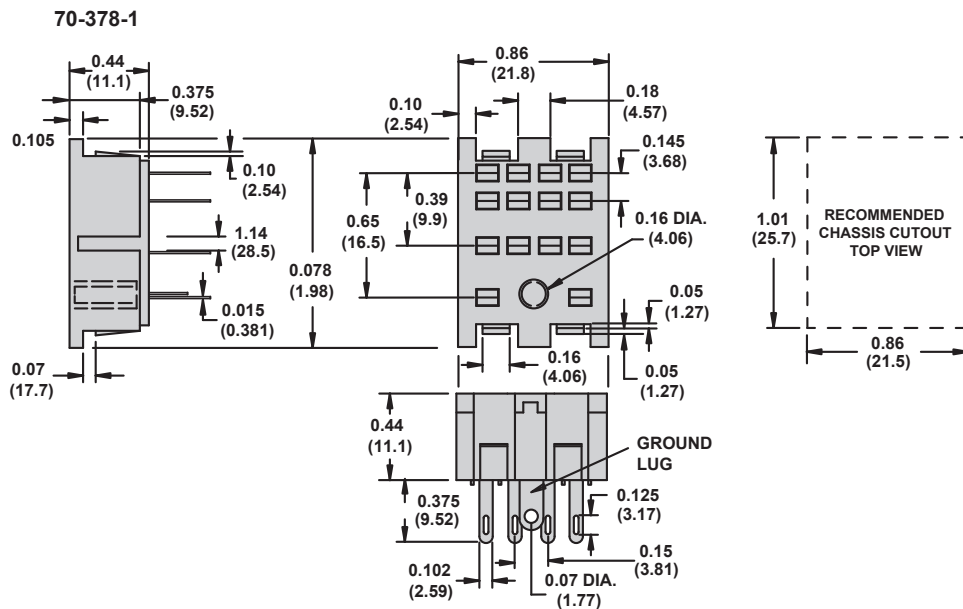

*Dimensions,
Wiring Diagrams*

Magnecraft General Purpose Relays
Socket Specifications
70-378-1 and 70-379-1

Dimensions — inches (millimeters)

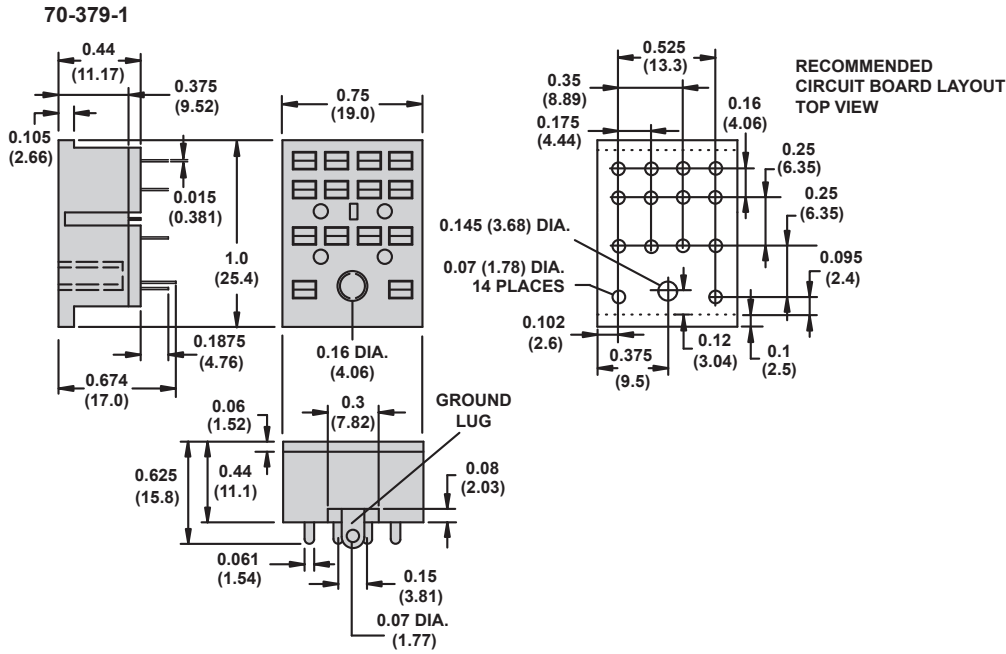

Wiring Diagrams

70-378-1

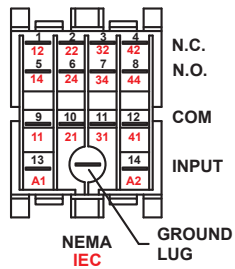

70-379-1

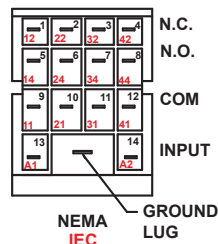

Specifications, Dimensions

Magnecraft General Purpose Relays

Socket Specifications

70-401-1 and 70-402-1

Socket Specifications

Part Number	70-401-1	70-402-1
Contact Configuration	DPDT	DPDT
Number of Terminals	8	8
Mounting Style	Chassis	PCB
Current Rating	10 A	10 A
Nominal Voltage Rating	300 V	300 V
Storage Temperature Range	-40 to +105 °C (-40 to +221 °F)	-40 to +105 °C (-40 to +221 °F)
Operating Temperature Range	-40 to +55 °C (-40 to +131 °F)	-40 to +55 °C (-40 to +131 °F)
Protection Category (Fingersafe)	–	–
Internal Metal Tracks	Copper Alloy, Zinc Plated	Copper Alloy, Zinc Plated
Screw Terminals	Copper Alloy, Zinc Plated	Copper Alloy, Zinc Plated
Screw Style	Combination Head	–
Screw Size	M3.5 mm	–
Maximum Screw Torque	9 Lb-in / 1.0 N•m	–
Terminal Connection	Solder	PCB
Terminal Layout	Mix	Mix
Maximum Wire Size	Solid Cu: (Output): 18 AWG, 0.8 mm ² Stranded Cu: (Output): 18 AWG, 0.8 mm ²	–
DIN Rail Mounting, EN 60715	–	–
Chassis Mount Screw Torque	7 Lb-in / 0.8 N•m	–
Flammability Rating	94V-0	94V-0
Weight	6.2 g (0.22 oz)	6.5 g (0.23 oz)
Agency Approvals	UL (E70550), CE, RoHS	UL (E70550), CE, RoHS

Dimensions — inches (millimeters)

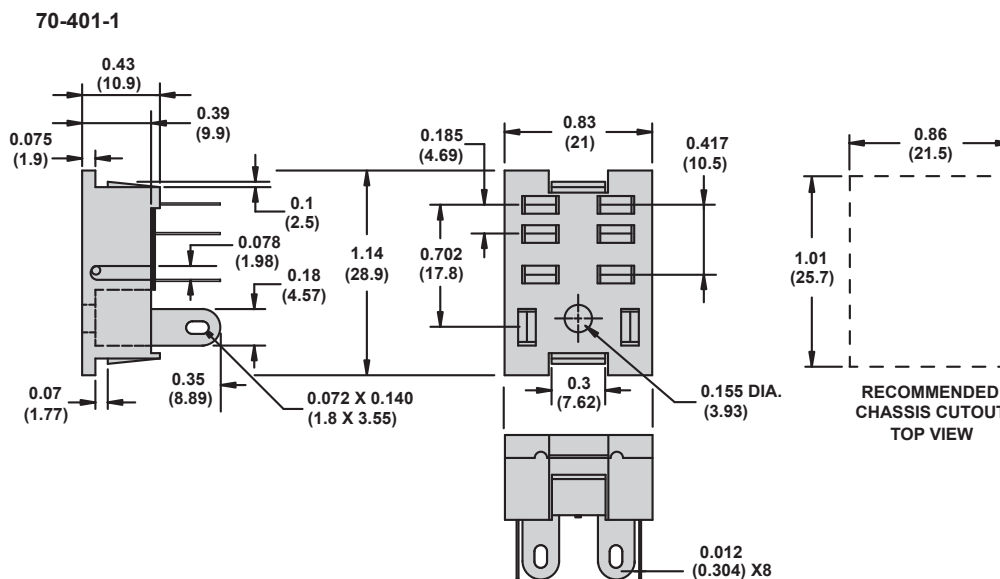

*Dimensions,
Wiring Diagrams*

Magnecraft General Purpose Relays
Socket Specifications
70-401-1 and 70-402-1

Dimensions — inches (millimeters)

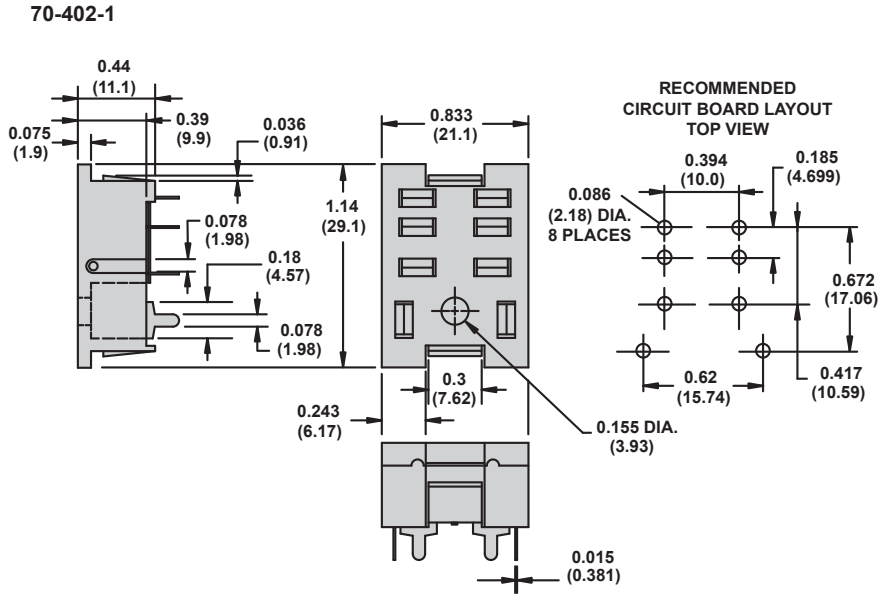

Wiring Diagrams

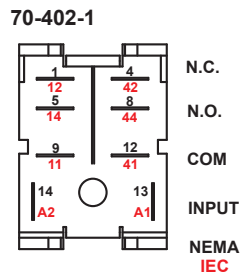
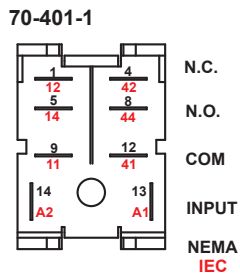

Specifications, Dimensions

Magnecraft General Purpose Relays

Socket Specifications

70-459-1, 70-461-1, and 70-463-1

Socket Specifications

Part Number	70-459-1	70-461-1	70-463-1
Contact Configuration	DPDT	4PDT	3PDT
Number of Terminals	8	14	11
Mounting Style	Panel / DIN rail	Panel / DIN rail	Panel / DIN rail
Current Rating	10 A	10 A	15 A
Nominal Voltage Rating	300 V	300 V	300 V
Storage Temperature Range	-40 to +105 °C (-40 to +221°F)	-40 to +105 °C (-40 to +221 °F)	-40 to +105 °C (-40 to +221 °F)
Operating Temperature Range	-40 to +55 °C (-40 to +131 °F)	-40 to +70 °C (-40 to +158 °F)	-40 to +55 °C (-40 to +131 °F)
Protection Category (Fingersafe)	–	–	–
Internal Metal Tracks	Copper Alloy, Zinc Plated	Copper Alloy, Zinc Plated	Copper Alloy, Zinc Plated
Screw Terminals	Steel, Zinc Plated	Steel, Zinc Plated	Steel, Zinc Plated
Screw Style	Combination Head	Combination Head	Combination Head
Screw Size	M3.5 mm	M3 mm	M3.5 mm
Maximum Screw Torque	9 Lb-in / 1.0 N•m	7 Lb-in / 0.8 N•m	9 Lb-in / 1.0 N•m
Terminal Connection	Screw Clamping	Elevator	Screw Clamping
Terminal Layout	Mix	Separate	Mix
Maximum Wire Size	Solid Cu: 12 / 14 (2) AWG, 4 / 2.5 (2) mm ² Stranded Cu: 12 / 14 (2) AWG, 4 / 2.5 (2) mm ²	Solid Cu: 14 / 16 (2) AWG, 2.5 / 1.5 (2) mm ² Stranded Cu: 14 / 16 (2) AWG, 2.5 / 1.5 (2) mm ²	Solid Cu: 12 / 14 (2) AWG, 4 / 2.5 (2) mm ² Stranded Cu: 12 / 14 (2) AWG, 4 / 2.5 (2) mm ²
DIN Rail Mounting, EN 60715	35 mm	35 mm	35 mm
Chassis Mount Screw Torque	7 Lb-in / 0.8 N•m	7 Lb-in / 0.8 N•m	7 Lb-in / 0.8 N•m
Flammability Rating	94V-0	94V-0	94V-0
Weight	50 g (1.76 oz)	50 g (1.76 oz)	51 g (1.79 oz)
Agency Approvals	UL (E70550), CE, CSA (LR97899), RoHS	UL (E70550), CE, CSA (LR97899), RoHS	UL (E70550), CE, CSA (LR97899), RoHS

Dimensions — inches (millimeters)

70-459-1

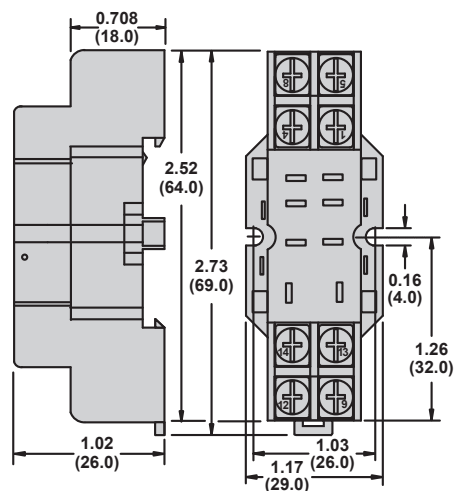

70-461-1

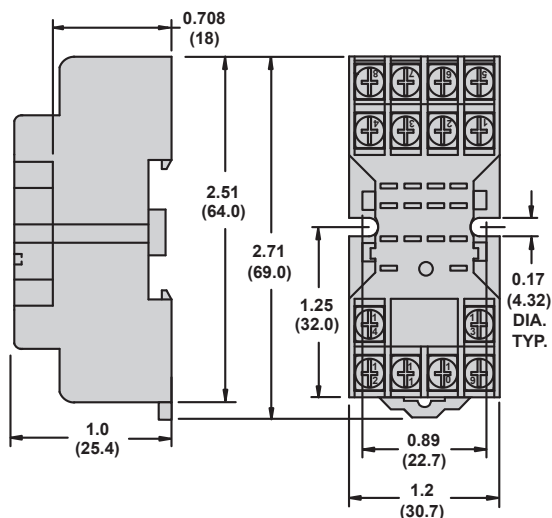

Dimensions, Wiring Diagrams

Magnecraft General Purpose Relays

Socket Specifications

70-459-1, 70-461-1, and 70-463-1

Dimensions — inches (millimeters)

70-463-1

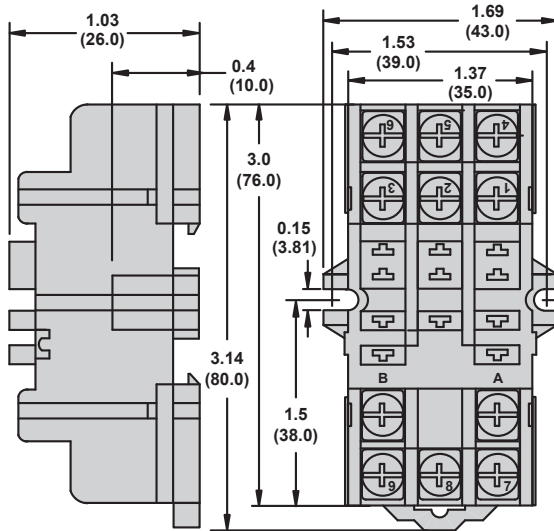

Wiring Diagrams

70-459-1

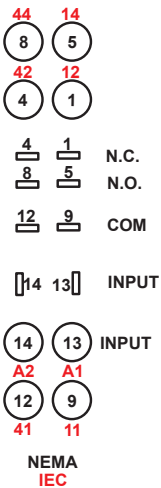

70-461-1

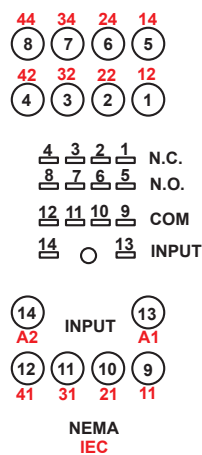

70-463-1

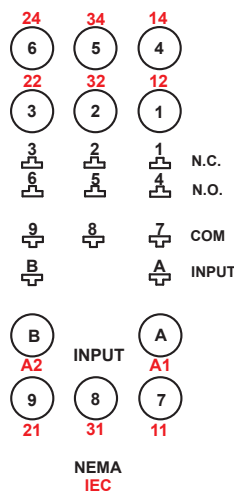

*Specifications,
Dimensions,
Wiring Diagrams*

Magnecraft General Purpose Relays
Socket Specifications
70-464-1 and 70-465-1

Socket Specifications

Part Number	70-464-1	70-465-1
Contact Configuration	DPDT	3PDT
Number of Terminals	8	11
Mounting Style	Panel / DIN rail	Panel / DIN rail
Current Rating	15 / 10 A	15 / 5 A
Nominal Voltage Rating	300 / 600 V	300 / 600 V
Storage Temperature Range	-40 to +105 °C (-40 to +221 °F)	-40 to +105 °C (-40 to +221 °F)
Operating Temperature Range	-40 to +55 °C (-40 to +131 °F)	-40 to +55 °C (-40 to +131 °F)
Protection Category (Fingersafe)	–	–
Internal Metal Tracks	Copper Alloy, Zinc Plated	Copper Alloy, Zinc Plated
Screw Terminals	Steel, Zinc Plated	Steel, Zinc Plated
Screw Style	Combination Head	Combination Head
Screw Size	M3.5 mm	M3.5 mm
Maximum Screw Torque	9 Lb-in / 1.0 N•m	9 Lb-in / 1.0 N•m
Terminal Connection	Screw Clamping	Screw Clamping
Terminal Layout	Mix	Mix
Maximum Wire Size	Solid Cu: 12/14 (2) AWG, 4/2.5 (2) mm ² Stranded Cu: 12/14 (2) AWG, 4/2.5 (2) mm ²	Solid Cu: 12/14 (2) AWG, 4/2.5 (2) mm ² Stranded Cu: 12/14 (2) AWG, 4/2.5 (2) mm ²
DIN Rail Mounting, EN 60715	35 mm	35 mm
Chassis Mount Screw Torque	7 Lb-in / 0.8 N•m	7 Lb-in / 0.8 N•m
Flammability Rating	94V-0	94V-0
Weight	40 g (1.41 oz)	57 g (2.01 oz)
Agency Approvals	UL (E70550), CE, CSA (LR97899), RoHS	UL (E70550), CE, CSA (LR97899), RoHS

Dimensions — inches (millimeters)

70-464-1

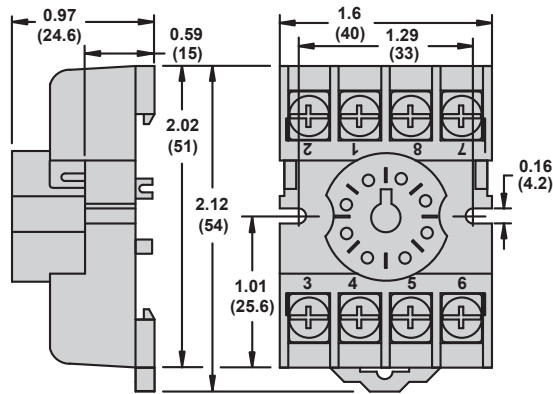

70-465-1

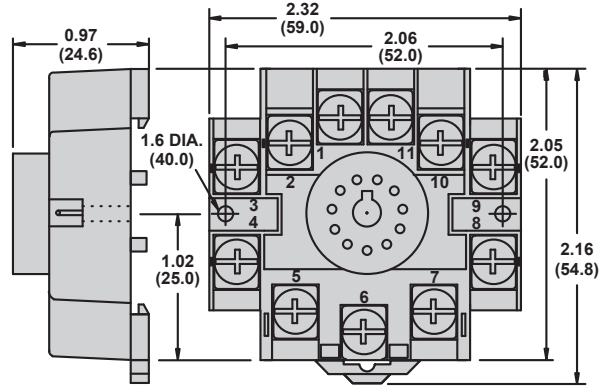

Wiring Diagrams

70-464-1

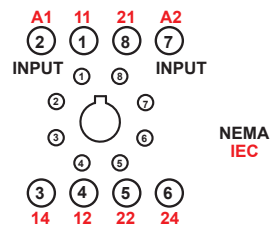

70-465-1

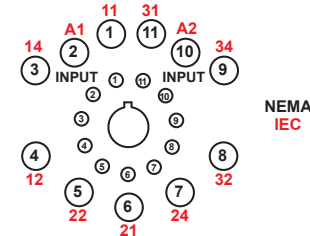

Specifications, Dimensions

Magnecraft General Purpose Relays

Socket Specifications

70-750DL8-1 and 70-750DL11-1

Socket Specifications

Part Number	70-750DL8-1	70-750DL11-1
Contact Configuration	DPDT	3PDT
Number of Terminals	8	11
Mounting Style	Panel / DIN rail	Panel / DIN rail
Current Rating	16 A	16 A
Nominal Voltage Rating	300 V	600 V
Storage Temperature Range	-40 to +105 °C (-40 to +221 °F)	-40 to +105 °C (-40 to +221 °F)
Operating Temperature Range	-40 to +55 °C (-40 to +131 °F)	-40 to +55 °C (-40 to +131 °F)
Protection Category (Fingersafe)	IP 20	IP 20
Internal Metal Tracks	Copper Alloy, Zinc Plated	Copper Alloy, Zinc Plated
Screw Terminals	Steel, Zinc Plated	Steel, Zinc Plated
Screw Style	Combination Head	Combination Head
Screw Size	M3.5 mm	M3.5 mm
Maximum Screw Torque	9 Lb-in / 1.0 N•m	9 Lb-in / 1.0 N•m
Terminal Connection	Screw Clamping	Screw Clamping
Terminal Layout	Mix	Mix
Maximum Wire Size	Solid Cu: 12/14 (2) AWG, 4/2.5 (2) mm ² Stranded Cu: 12/14 (2) AWG, 4/2.5 (2) mm ²	Solid Cu: 12/14 (2) AWG, 4/2.5 (2) mm ² Stranded Cu: 12/14 (2) AWG, 4/2.5 (2) mm ²
DIN Rail Mounting, EN 60715	35 mm	35 mm
Chassis Mount Screw Torque	7 Lb-in / 0.8 N•m	7 Lb-in / 0.8 N•m
Flammability Rating	94V-0	94V-0
Weight	60 g (2.12 oz)	78 g (2.75 oz)
Agency Approvals	UL (E70550), CE, CSA (LR40787), RoHS	UL (E70550), CE, CSA (LR40787), RoHS

Dimensions — inches (millimeters)

70-750DL11-1

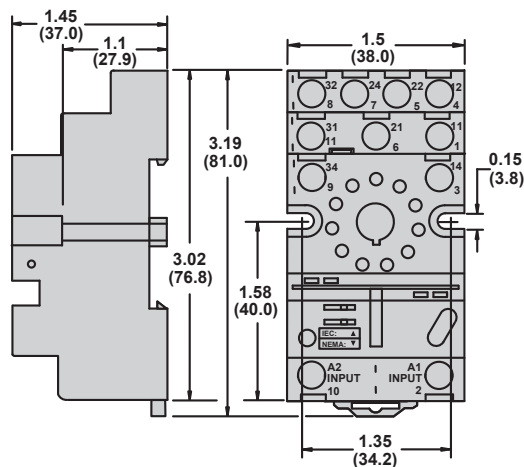

70-750DL8-1

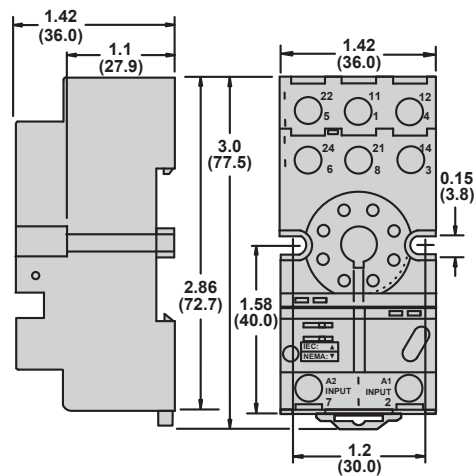

Wiring Diagrams, Specifications

Magnecraft General Purpose Relays

Socket Specifications

70-750DL8-1, 70-750DL11-1, 70-750E8, and 70-750E11-1

Wiring Diagrams

70-750DL11-1

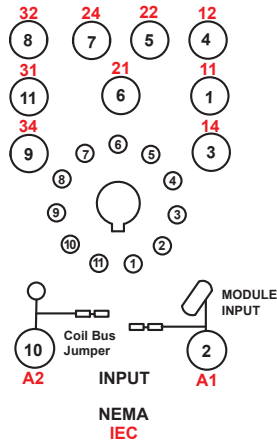

70-750DL8-1

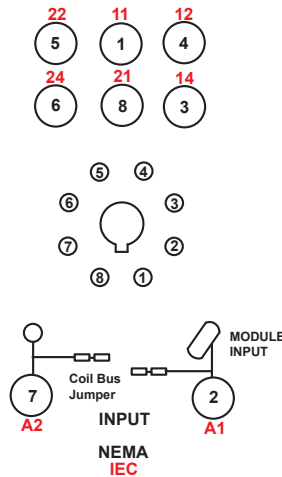

Socket Specifications

Part Number	70-750E8-1	70-750E11-1
Contact Configuration	DPDT	3PDT
Number of Terminals	8	11
Mounting Style	Panel / DIN rail	Panel / DIN rail
Current Rating	12 A	12 A
Nominal Voltage Rating	300 V	300 V
Storage Temperature Range	-40 to +105 °C (-40 to +221 °F)	-40 to +105 °C (-40 to +221 °F)
Operating Temperature Range	-40 to +55 °C (-40 to +131 °F)	-40 to +55 °C (-40 to +131 °F)
Protection Category (Fingersafe)	IP 20	IP 20
Internal Metal Tracks	Copper Alloy, Zinc Plated	Copper Alloy, Zinc Plated
Screw Terminals	Steel, Zinc Plated	Steel, Zinc Plated
Screw Style	Combination Head	Combination Head
Screw Size	M3.5 mm	M3.5 mm
Maximum Screw Torque	9 Lb-in / 1.0 N•m	9 Lb-in / 1.0 N•m
Terminal Connection	Elevator	Elevator
Terminal Layout	Separate	Separate
Maximum Wire Size	Solid Cu: 12/14 (2) AWG, 4/2.5 (2) mm ² Stranded Cu: 12/14 (2) AWG, 4/2.5 (2) mm ²	Solid Cu: 12/14 (2) AWG, 4/2.5 (2) mm ² Stranded Cu: 12/14 (2) AWG, 4/2.5 (2) mm ²
DIN Rail Mounting, EN 60715	35 mm	35 mm
Chassis Mount Screw Torque	7 Lb-in / 0.8 N•m	7 Lb-in / 0.8 N•m
Flammability Rating	94V-0	94V-0
Weight	85 g (3.0 oz)	85 g (3.0 oz)
Agency Approvals	UL (E70550), CE, CSA (LR40787), RoHS	UL (E70550), CE, CSA (LR40787), RoHS

Dimensions, Wiring Diagrams

Magnecraft General Purpose Relays

Socket Specifications

70-750E8 and 70-750E11-1

Dimensions — inches (millimeters)

70-750E11-1

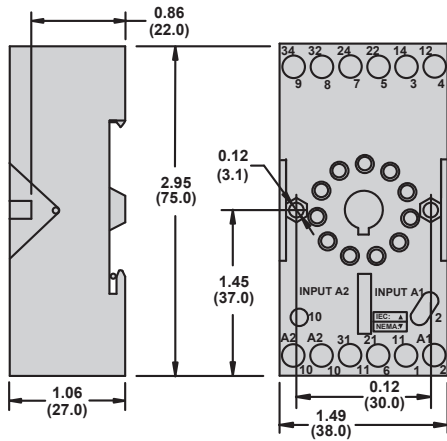

70-750E8-1

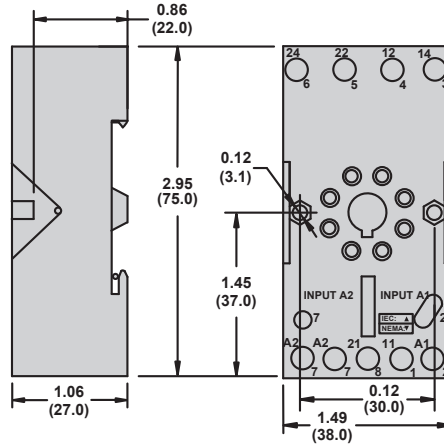

Wiring Diagrams

70-750E11-1

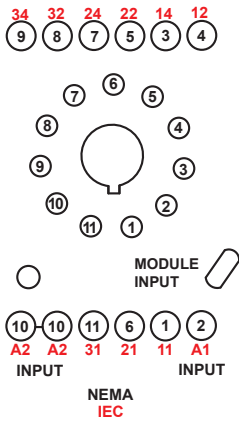

70-750E8-1

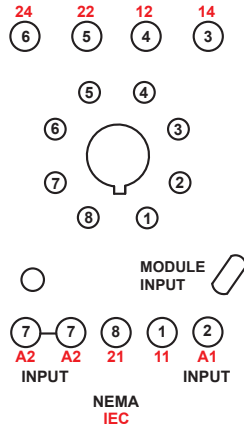

Specifications, Dimensions

Magnecraft General Purpose Relays

Socket Specifications

70-750EL8-1 and 70-750EL11-1

Socket Specifications

Part Number	70-750EL8-1	70-750EL11-1
Contact Configuration	DPDT	3PDT
Number of Terminals	8	11
Mounting Style	Panel / DIN rail	Panel / DIN rail
Current Rating	16 A	16 A
Nominal Voltage Rating	300 V	300 V
Storage Temperature Range	-40 to +105 °C (-40 to +221 °F)	-40 to +105 °C (-40 to +221 °F)
Operating Temperature Range	-40 to +55 °C (-40 to +131 °F)	-40 to +55 °C (-40 to +131 °F)
Protection Category (Fingersafe)	IP 20	IP20
Internal Metal Tracks	Copper Alloy, Zinc Plated	Copper Alloy, Zinc Plated
Screw Terminals	Steel, Zinc Plated	Steel, Zinc Plated
Screw Style	Combination Head	Combination Head
Screw Size	M3.5 mm	M3.5 mm
Maximum Screw Torque	9 Lb-in / 1.0 N•m	9 Lb-in / 1.0 N•m
Terminal Connection	Elevator	Elevator
Terminal Layout	Separate	Separate
Maximum Wire Size	Solid Cu: 12/14 (2) AWG, 4/2.5 (2) mm ² Stranded Cu: 12/14 (2) AWG, 4/2.5 (2) mm ²	Solid Cu: 12 / 14 (2) AWG, 4 / 2.5 (2) mm ² Stranded Cu: 12 / 14 (2) AWG, 4 / 2.5 (2) mm ²
DIN Rail Mounting, EN 60715	35 mm	35 mm
Chassis Mount Screw Torque	7 Lb-in / 0.8 N•m	7 Lb-in / 0.8 N•m
Flammability Rating	94V-0	94V-0
Weight	79 g (2.79 oz)	79 g (2.79 oz)
Agency Approvals	UL (E70550), CE, CSA (LR40787), RoHS	UL (E70550), CE, CSA (LR40787), RoHS

Dimensions — inches (millimeters)

70-750EL11-1

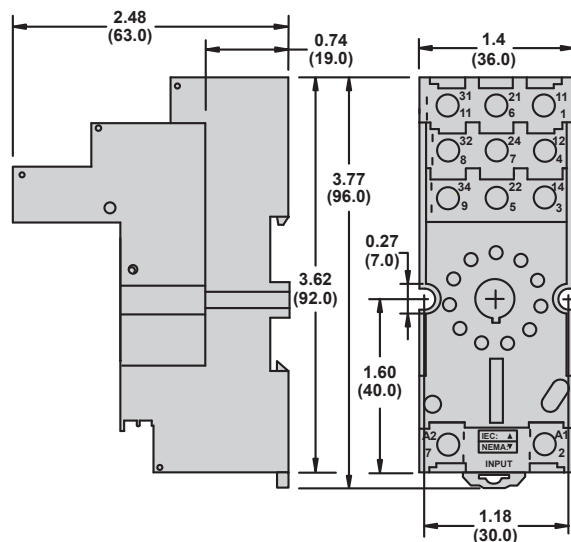

70-750EL8-1

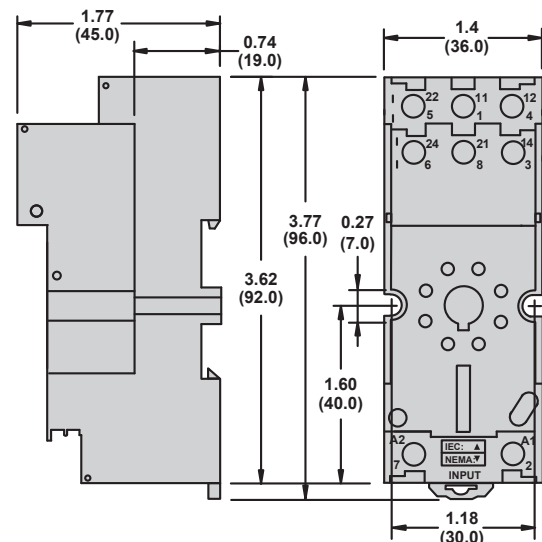

Wiring Diagrams, Specifications

Magnecraft General Purpose Relays

Socket Specifications

70-750EL8-1, 70-750EL11-1, 70-781D5R-1A, and 70-781T-1

Wiring Diagrams

70-750EL11-1

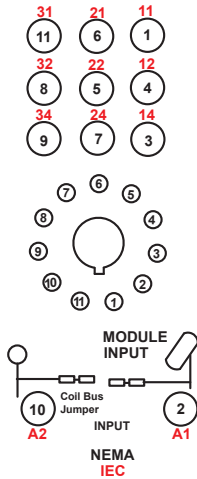

70-750EL8-1

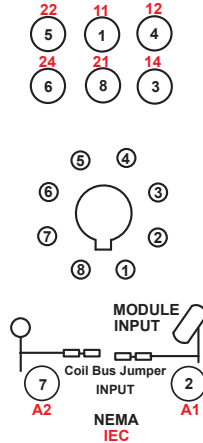

Socket Specifications

Part Number	70-781D5R-1A	70-781T-1
Contact Configuration	SPDT	SPDT
Number of Terminals	5	5
Mounting Style	Panel / DIN rail	PCB
Current Rating	16 A	10 A
Nominal Voltage Rating	300 V	300 V
Storage Temperature Range	-40 to +105 °C (-40 to +221 °F)	-40 to +105 °C (-40 to +221 °F)
Operating Temperature Range	-40 to +55 °C (-40 to +131 °F)	-40 to +55 °C (-40 to +131 °F)
Protection Category (Fingersafe)	IP 20	-
Internal Metal Tracks	Copper Alloy, Zinc Plated	Copper Alloy, Zinc Plated
Screw Terminals	Steel, Zinc Plated	Copper Alloy, Zinc Plated
Screw Style	Combination Head	-
Screw Size	M3 mm / M3.5 mm	-
Maximum Screw Torque	M3 : 9 Lb-in / 0.8 N•m; M3.5 : 9 Lb-in / 1.0 N•m	-
Terminal Connection	Screw Clamping	PCB
Terminal Layout	Mix	Mix
Maximum Wire Size	Solid Cu: 12 / 14 (2) AWG, 4 / 2.5 (2) mm ² Stranded Cu: 12 / 14 (2) AWG, 4 / 2.5 (2) mm ²	-
DIN Rail Mounting, EN 60715	35 mm	-
Chassis Mount Screw Torque	7 Lb-in / 0.8 N•m	-
Flammability Rating	94V-0	94V-0
Weight	31 g (1.09 oz)	18 g (0.63 oz)
Agency Approvals	UL (E70550), CE, CSA (168986), RoHS	UL (E70550), CE, RoHS

Dimensions, Wiring Diagrams

Magnecraft General Purpose Relays

Socket Specifications

70-781D5R-1A and 70-781T-1

Dimensions — inches (millimeters)

70-781D5R-1A

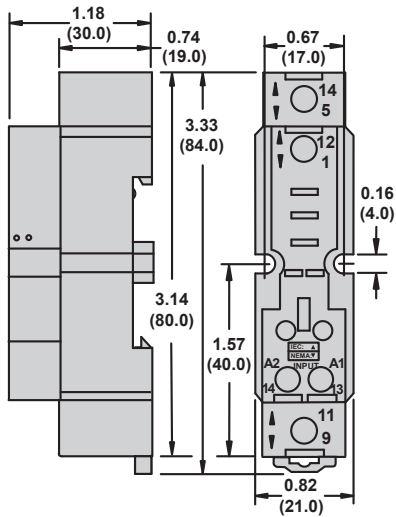

70-781T-1

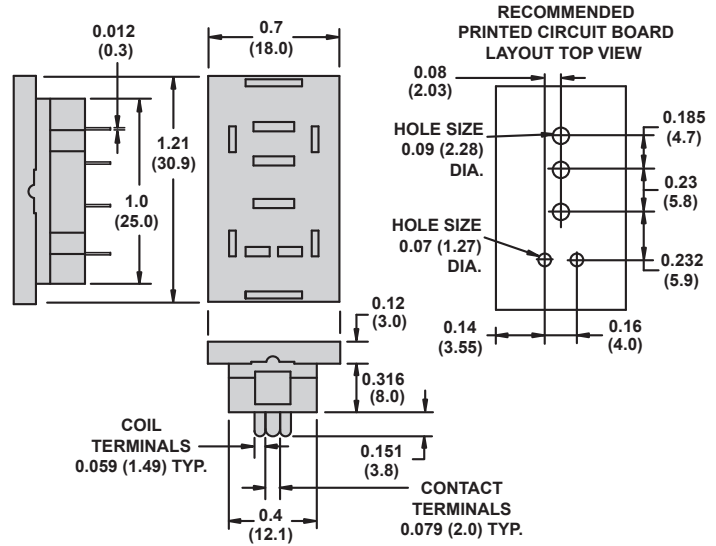

Wiring Diagrams

70-781D5R-1A

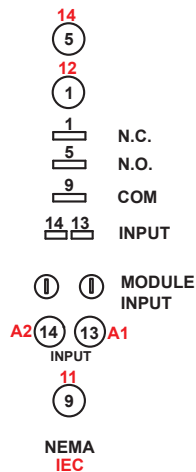

70-781T-1

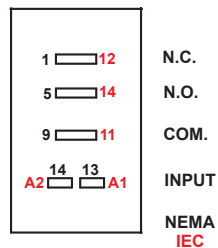

Specifications, Dimensions

Magnecraft General Purpose Relays

Socket Specifications

70-782D8-1A and 70-782D14-1

Socket Specifications

Part Number	70-782D8-1A	70-782D14-1
Contact Configuration	DPDT	4PDT
Number of Terminals	8	14
Mounting Style	Panel / DIN rail	Panel / DIN rail
Current Rating	16 A	10 A
Nominal Voltage Rating	300 V	300 V
Storage Temperature Range	-40 to +105 °C (-40 to +221 °F)	-40 to +105 °C (-40 to +221 °F)
Operating Temperature Range	-40 to +55 °C (-40 to +131 °F)	-40 to +70 °C (-40 to +158 °F)
Protection Category (Fingersafe)	IP 20	IP 20
Internal Metal Tracks	Copper Alloy, Zinc Plated	Copper Alloy, Zinc Plated
Screw Terminals	Steel, Zinc Plated	Steel, Zinc Plated
Screw Style	Combination Head	Combination Head
Screw Size	M3.5 mm	M3 mm
Maximum Screw Torque	9 Lb-in / 1.0 N•m	7 Lb-in / 0.8 N•m
Terminal Connection	Screw Clamping	Screw Clamping
Terminal Layout	Mix	Mix
Maximum Wire Size	Solid Cu: 12 / 14 (2) AWG, 4 / 2.5 (2) mm ² Stranded Cu: 12 / 14 (2) AWG, 4 / 2.5 (2) mm ²	Solid Cu: 12 / 14 (2) AWG, 4 / 2.5 (2) mm ² Stranded Cu: 12 / 14 (2) AWG, 4 / 2.5 (2) mm ²
DIN Rail Mounting, EN 60715	35 mm	35 mm
Chassis Mount Screw Torque	7 Lb-in / 0.8 N•m	7 Lb-in / 0.8 N•m
Flammability Rating	94V-0	94V-0
Weight	55 g (1.94 oz)	62 g (2.19 oz)
Agency Approvals	UL (E70550), CE, CSA (LR40787), RoHS	UL (E70550), CE, CSA (LR40787), RoHS

Dimensions — inches (millimeters)

70-782D8-1A

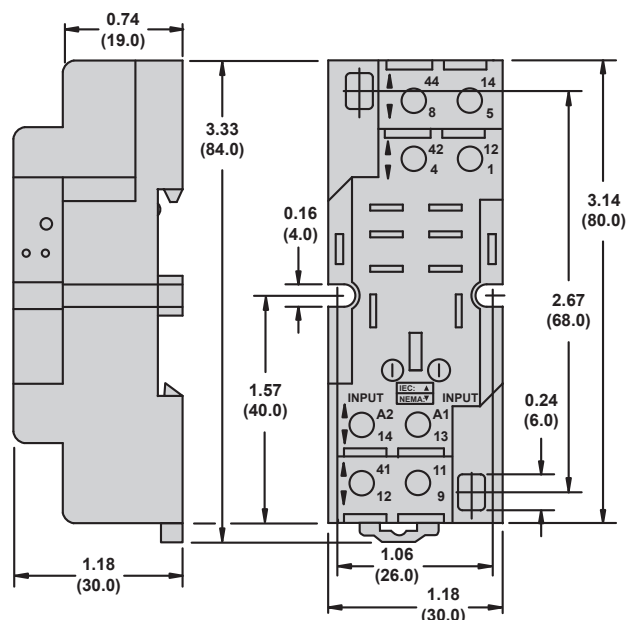

70-782D14-1

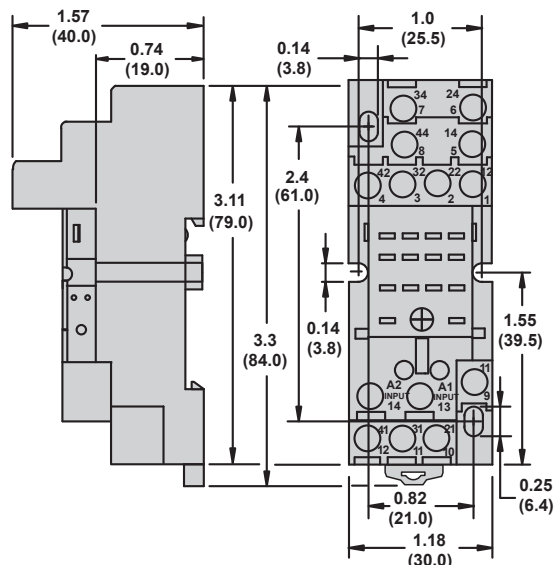

Wiring Diagrams, Specifications

Magnecraft General Purpose Relays

Socket Specifications

70-782D8-1A, 70-782D14-1, 70-782E14-1,
and 70-782EL8-1

Wiring Diagrams

70-782D8-1A

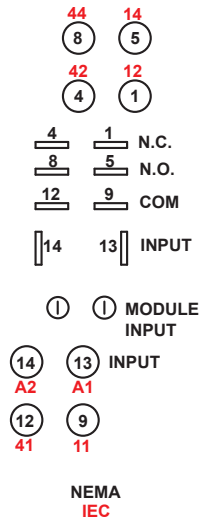

70-782D14-1

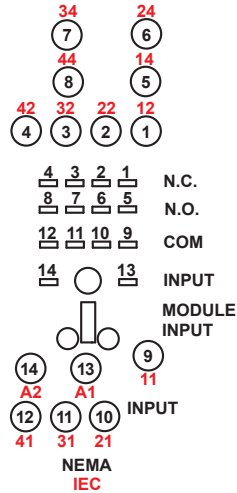

Socket Specifications

Part Number	70-782E14-1	70-782EL8-1
Contact Configuration	4PDT	DPDT
Number of Terminals	14	8
Mounting Style	Panel / DIN rail	Panel / DIN rail
Current Rating	10 A	12 A
Nominal Voltage Rating	300 V	300 V
Storage Temperature Range	-40 to +105 °C (-40 to +221 °F)	-40 to +105 °C (-40 to +221 °F)
Operating Temperature Range	-40 to +70 °C (-40 to +158 °F)	-40 to +55 °C (-40 to +131 °F)
Protection Category (Fingersafe)	IP 20	IP 20
Internal Metal Tracks	Copper Alloy, Zinc Plated	Copper Alloy, Zinc Plated
Screw Terminals	Steel, Zinc Plated	Steel, Zinc Plated
Screw Style	Combination Head	Combination Head
Screw Size	M3 mm	M3.5 mm
Maximum Screw Torque	7 Lb-in / 0.8 N•m	9 Lb-in / 1.0 N•m
Terminal Connection	Elevator	Elevator
Terminal Layout	Separate	Separate
Maximum Wire Size	Solid Cu: 14 / 16 (2) AWG, 2.5 / 1.5 (2) mm ² Stranded Cu: 14 / 16 (2) AWG, 2.5 / 1.5 (2) mm ²	Solid Cu: 12 / 14 (2) AWG, 4 / 2.5 (2) mm ² Stranded Cu: 12 / 14 (2) AWG, 4 / 2.5 (2) mm ²
DIN Rail Mounting, EN 60715	35 mm	35 mm
Chassis Mount Screw Torque	7 Lb-in / 0.8 N•m	7 Lb-in / 0.8 N•m
Flammability Rating	94V-0	94V-0
Weight	56 g (1.98 oz)	46 g (1.62 oz)
Agency Approvals	UL (E70550), CE, CSA (LR40787), RoHS	UL (E70550), CE, CSA (LR40787), RoHS

*Dimensions,
Wiring Diagrams*

Magnecraft General Purpose Relays

Socket Specifications

70-782E14-1 and 70-782EL8-1

Dimensions — inches (millimeters)

70-782EL8-1

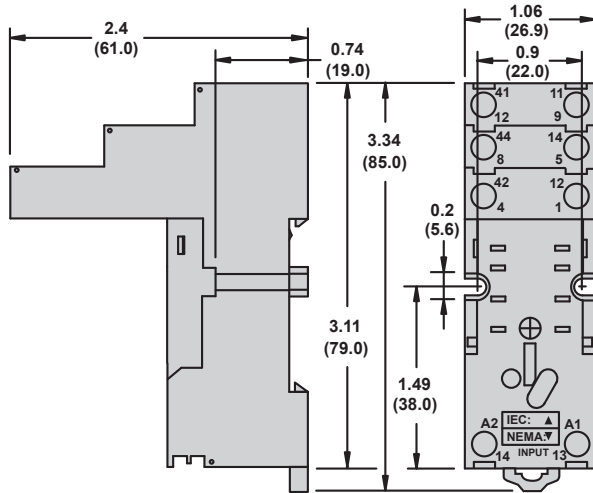

70-782E14-1

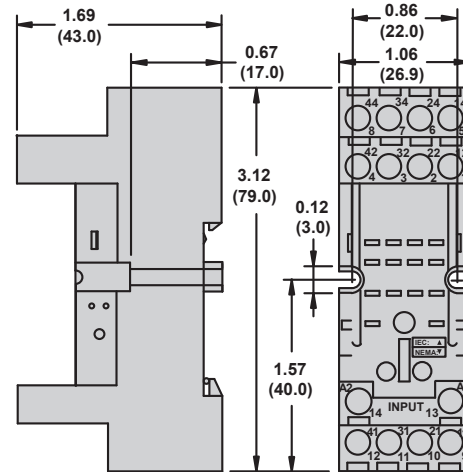

Wiring Diagrams

70-782EL8-1

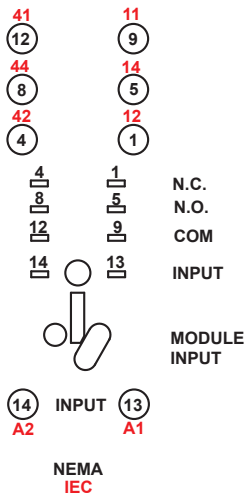

70-782E14-1

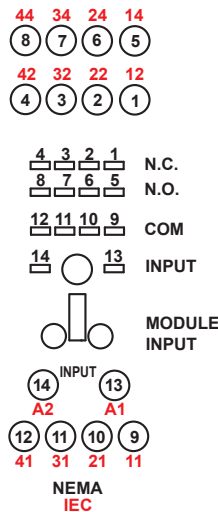

*Specifications,
Dimensions,
Wiring Diagram*

Magnecraft General Purpose Relays
Socket Specifications
70-782EL14-1

Socket Specifications

Part Number	70-782EL14-1
Contact Configuration	4PDT
Number of Terminals	14
Mounting Style	Panel / DIN rail
Current Rating	10 A
Nominal Voltage Rating	300 V
Storage Temperature Range	-40 to +105 °C (-40 to +221 °F)
Operating Temperature Range	-40 to +70 °C (-40 to +158 °F)
Protection Category (Fingersafe)	IP 20
Internal Metal Tracks	Copper Alloy, Zinc Plated
Screw Terminals	Steel, Zinc Plated
Screw Style	Combination Head
Screw Size	M3 mm
Maximum Screw Torque	7 Lb-in / 0.8 N·m
Terminal Connection	Elevator
Terminal Layout	Separate
Maximum Wire Size	Solid Cu: 14 / 16 (2) AWG, 2.5 / 1.5 (2) mm ² Stranded Cu: 14 / 16 (2) AWG, 2.5 / 1.5 (2) mm ²
DIN Rail Mounting, EN 60715	35 mm
Chassis Mount Screw Torque	7 Lb-in / 0.8 N·m
Flammability Rating	94V-0
Weight	62 g (2.19 oz)
Agency Approvals	UL (E70550), CE, CSA (LR40787), RoHS

Dimensions — inches (millimeters)

70-782EL14-1

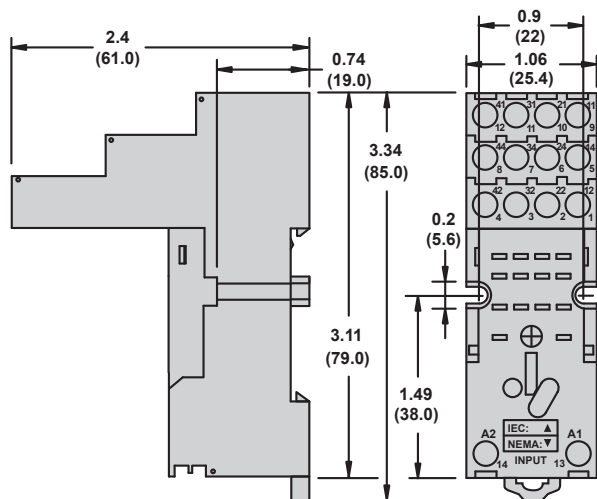

Wiring Diagram

70-782EL14-1

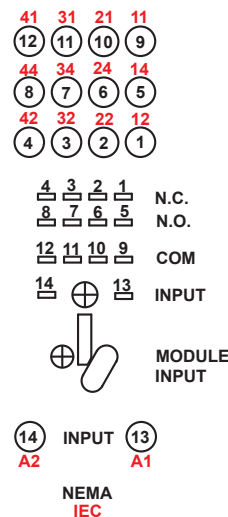

Specifications

Magnecraft General Purpose Relays

Socket Specifications

70-783D11-1A and 70-784D14-1

Socket Specifications

Part Number	70-783D11-1A	70-784D14-1
Contact Configuration	3PDT	4PDT
Number of Terminals	11	14
Mounting Style	Panel / DIN rail	Panel / DIN rail
Current Rating	16 A	16 A
Nominal Voltage Rating	300 V	300 V
Storage Temperature Range	-40 to +105 °C (-40 to +221 °F)	-40 to +105 °C (-40 to +221 °F)
Operating Temperature Range	-40 to +55 °C (-40 to +131 °F)	-40 to +55 °C (-40 to +131 °F)
Protection Category (Fingersafe)	IP 20	IP 20
Internal Metal Tracks	Copper Alloy, Zinc Plated	Copper Alloy, Zinc Plated
Screw Terminals	Steel, Zinc Plated	Steel, Zinc Plated
Screw Style	Combination Head	Combination Head
Screw Size	M3.5 mm	M3.5 mm
Maximum Screw Torque	9 Lb-in / 1.0 N•m	9 Lb-in / 1.0 N•m
Terminal Connection	Screw Clamping	Screw Clamping
Terminal Layout	Mix	Mix
Maximum Wire Size	Solid Cu: 12 / 14 (2) AWG, 4 / 2.5 (2) mm ² Stranded Cu: 12 / 14 (2) AWG, 4 / 2.5 (2) mm ²	Solid Cu: 12 / 14 (2) AWG, 4 / 2.5 (2) mm ² Stranded Cu: 12 / 14 (2) AWG, 4 / 2.5 (2) mm ²
DIN Rail Mounting, EN 60715	35 mm	35 mm
Chassis Mount Screw Torque	7 Lb-in / 0.8 N•m	7 Lb-in / 0.8 N•m
Flammability Rating	94V-0	94V-0
Weight	55 g (1.94oz)	62 g (2.19 oz)
Agency Approvals	CE, RoHS, UL,(E70550) CSA (LR40787)	CE, RoHS, UL,(E70550) CSA (LR40787)

*Dimensions,
Wiring Diagrams*

Magnecraft General Purpose Relays
Socket Specifications
70-783D11-1A and 70-784D14-1

Dimensions — inches (millimeters)

70-783D11-1A

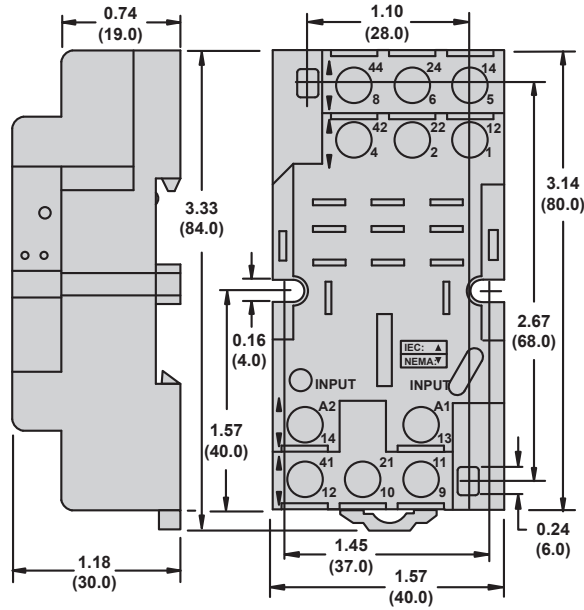

70-784D14-1

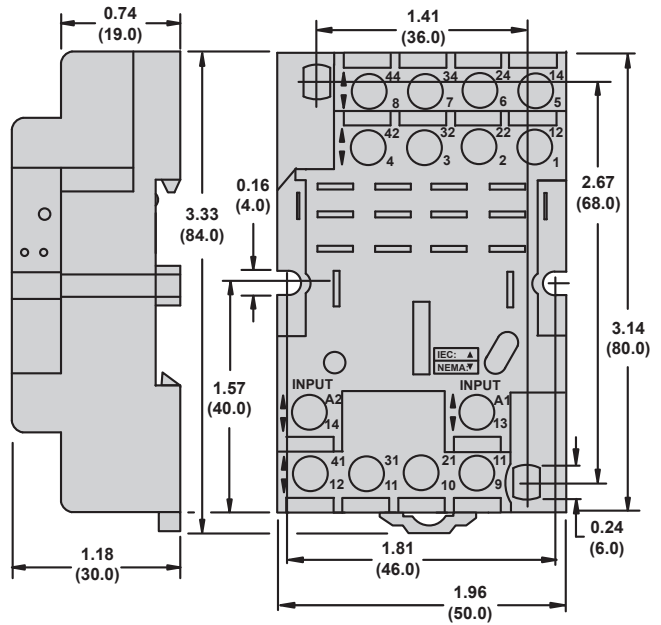

Wiring Diagrams

70-783D11-1A

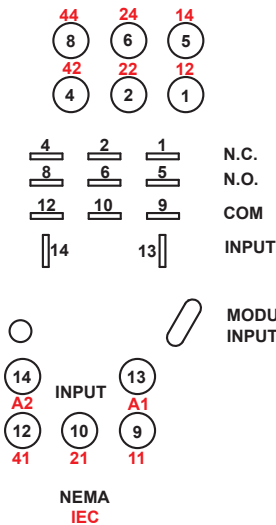

70-784D14-1

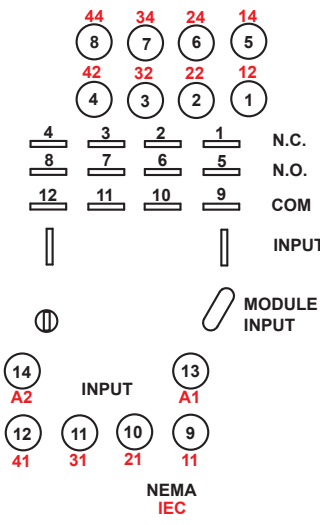

*Specifications,
Dimensions,
Wiring Diagrams*

Magnecraft General Purpose Relays
Socket Specifications
70-788EL11-1

Socket Specifications

Part Number	70-788EL11-1
Contact Configuration	3PDT
Number of Terminals	11
Mounting Style	DIN rail
Current Rating	25 A
Nominal Voltage Rating	300 V
Storage Temperature Range	-40 to +105 °C (-40 to +221 °F)
Operating Temperature Range	-40 to +55 °C (-40 to +131 °F)
Protection Category (Fingersafe)	IP 20
Internal Metal Tracks	Copper Alloy, Zinc Plated
Screw Terminals	Steel, Zinc Plated
Screw Style	Combination Head
Screw Size	M3.5 mm
Maximum Screw Torque	9 Lb-in / 1.0 N•m
Terminal Connection	Elevator
Terminal Layout	Separate
Maximum Wire Size	Solid Cu: 10 / 14 (2) AWG, 6 / 2.5 (2) mm ² Stranded Cu: 10 / 14 (2) AWG, 6 / 2.5 (2) mm ²
DIN Rail Mounting, EN 60715	35 mm
Chassis Mount Screw Torque	7 Lb-in / 0.8 N•m
Flammability Rating	94V-0
Weight	96 g (3.39 oz)
Agency Approvals	UL (E70550), CE, CSA (LR40787), RoHS

Dimensions — inches (millimeters)

70-788EL11-1

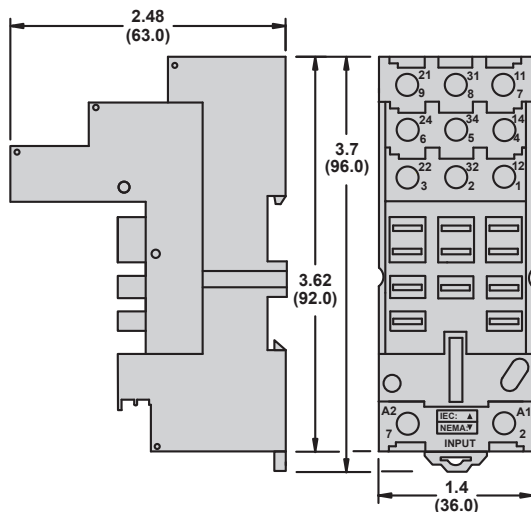

Wiring Diagram

70-788EL11-1

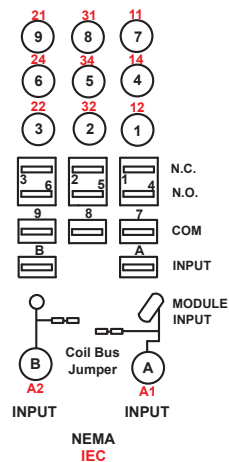

Specifications, Dimensions

Magnecraft General Purpose Relays

Mounting Adapter Specifications

Mounting Adapter Specifications

Part Number	16-781C	16-782C	16-783C	16-784C	16-781C1	16-782C2	16-783C1	16-784C1
Mounting Style	DIN rail / panel				Panel			
Mating Relays	781 Series	792 Series 782 Series	783 Series	784 Series	781 Series	792 Series 782 Series	783 Series	784 Series
Agency Approvals	RoHS							

Key Features

- No need to purchase a socket
- DIN or Panel mounting
- Plastic construction
- Light weight
- Low cost
- Low profile
- Write-On label
- Narrow mounting
- Easy termination



Mounting Adapter Dimensions — inches (millimeters)

All DIN Adapters

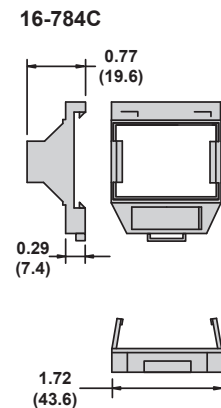
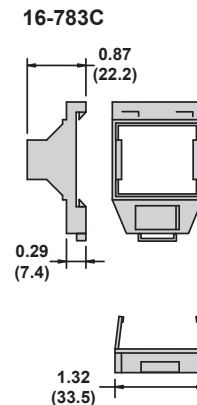
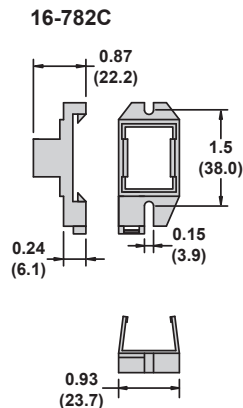
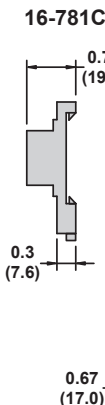
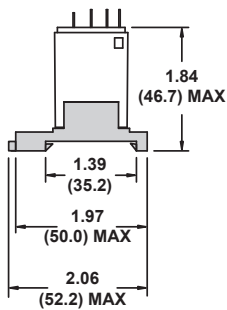

All Flange Adapters

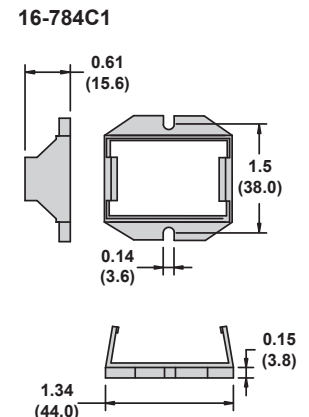
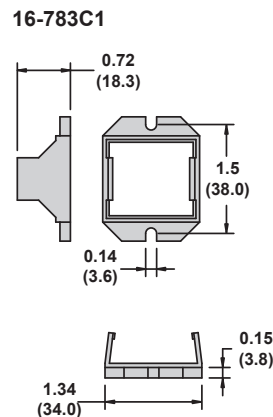
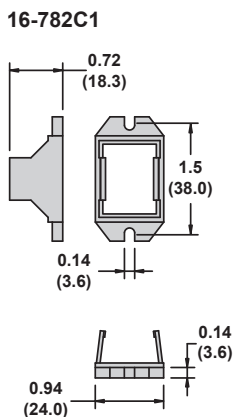
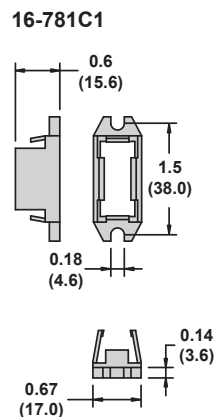
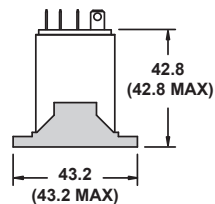

Contents

Magnecraft General Purpose Relays Socket Accessories

■ Overview	67
■ Hold-Down Clips	68
■ Insulated Coil Bus Jumper System	71
■ DIN Rail and DIN Clip	71
■ ID Tags	71
■ Panel Mount Adapter	72
■ Socket Modules	72

Overview

Magnecraft General Purpose Relays Socket Accessories

Product Overview

Hold-Down Clips

Safely secure relay to socket.
Available in plastic or stainless steel.



Socket Modules

Allow for optional circuit protection (Diode, MOV or RC) or status indicator LED. Modules plug into mating sockets.



DIN Rail and Locking End Clip

Enables quick installation and removal of sockets.

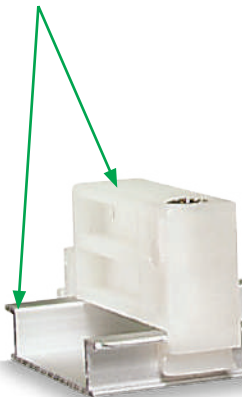

Insulated Coil Bus Jumper System

Allows for connection to adjacent sockets without any additional wiring and no tools necessary.



Write-On ID Tags

Enables identification of relays in multi-relay circuits. Tag snaps onto mating socket.

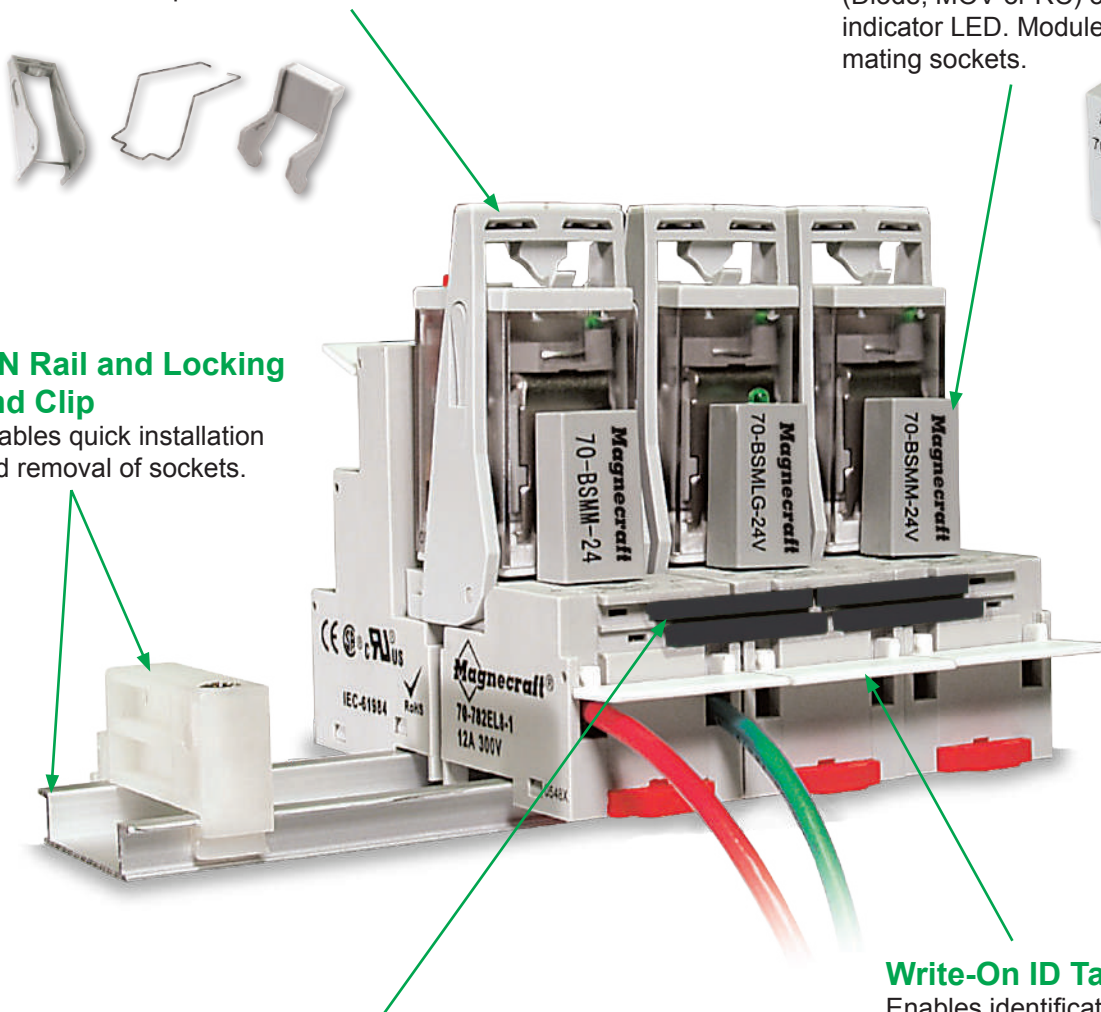

Selection

Magnecraft General Purpose Relays

Socket Accessories

Hold-Down Clips

The table below is designed to allow for easy selection of Magnecraft hold-down clips based on socket and relay compatibility.

Key Features

- Stainless steel spring clips are designed to secure the relay to the socket in harsh environments
- Plastic ejector clips are designed to secure and eject relays from tight, multi-socket applications
- Plastic ID clips are designed to allow for easy identification of circuits in multi-relay applications; an ID tag is supplied with each clip

Socket Part Number	Relays	Clip Part Number	Clip Type
70-124-2	788XBX / 788XCX	16-1351	Spring Clip
70-178-1	788XBX / 788XCX	16-1351	Spring Clip
70-178-2	788XBX / 788XCX	16-1351	Spring Clip
70-378-1	792XDX Control, 782XDXH	16-1342	Spring Clip
70-379-1	792XDX Control, 782XDXH	16-1342	Spring Clip
70-401-1	782XBX Power	16-1342	Spring Clip
70-402-1	782XBX Power	16-1342	Spring Clip
70-459-1	782XBX Power	16-1342	Spring Clip
70-461-1	792XDX Control, 782XDXH	16-1342	Spring Clip
70-463-1	788XBX / 788XCX	16-1351	Spring Clip
70-464-1	750XBX, 750XBXH	16-1351	Spring Clip
70-465-1	750XCX, 750XCXH	16-1351	Spring Clip
70-750DL8-1	750XBX	16-1332	Spring Clip
	750XBXH	16-1351	Spring Clip
70-750DL11-1	750XCX	16-1332	Spring Clip
	750XCXH	16-1351	Spring Clip
70-750E8-1	750XBX	16-1344	Spring Clip
	750XBX, 750XBXH	16-1351	Spring Clip
70-750E11-1	750XCX, 750XCXH	16-1351	Spring Clip
70-750EL8-1	750XBX	16-1351	Spring Clip
70-750EL11-1	750XCX	16-1351	Spring Clip
70-781D5R-1A	781XAX	16-781IDC	ID Clip
		16-781SC	Spring Clip
70-781T-1	781XAX	16-781SC	Spring Clip
70-782D8-1A	782XBX Power	16-1342	Spring Clip
		16-782IDC	ID Clip
		16-782PC-1	Ejector Clip
70-782D14-1	792XBX / 792XDX Control	16-782SC	Spring Clip
	792XBX / 792XDX Control (Full-feature cover only)	16-782PC-1	Ejector Clip
	782XDXH	16-1342	Spring Clip
70-782E14-1	792XBX / 792XDX Control	16-782SC	Spring Clip
	792XBX / 792XDX Control (Full-feature cover only)	16-782PC-1	Ejector Clip
	782XDXH	16-1342	Spring Clip
70-782EL8-1	792XBX Control	16-782SC	Spring Clip
	792XBX Control (Full-feature cover only)	16-782PC-1	Ejector Clip
70-782EL14-1	792XBX / 792XDX Control	16-782SC	Spring Clip
	792XBX / 792XDX Control (Full-feature cover only)	16-782PC-1	Ejector Clip
	782XDXH	16-1342	Spring Clip
70-783D11-1A	783XCX	16-783IDC	ID Clip
		16-783SC	Spring Clip
70-784D14-1	784XDX	16-784IDC	ID Clip
		16-784SC	Spring Clip
70-788EL11-1	788XBX / 788XCX	16-1351	Spring Clip

Dimensions

Magnecraft General Purpose Relays

Socket Accessories

Hold-Down Clips

Hold-Down Clip Dimensions — inches (millimeters)

16-781IDC

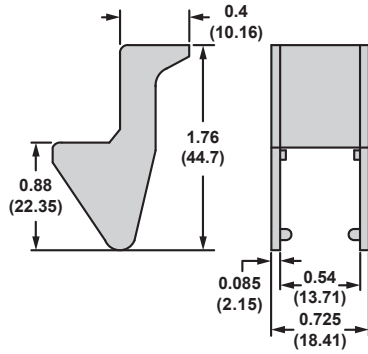

16-781SC

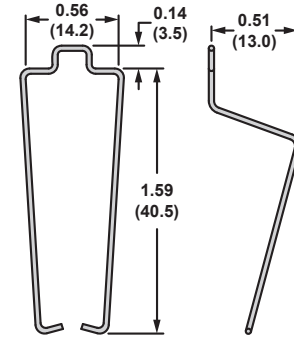

16-782IDC

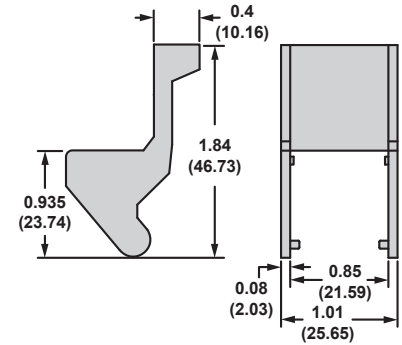

16-782PC

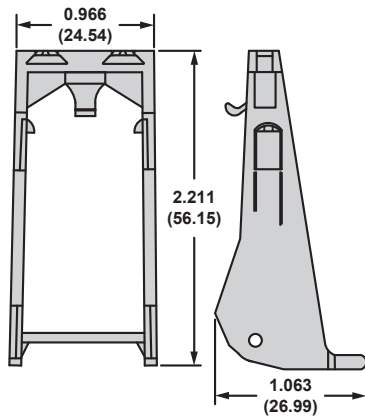

16-782SC

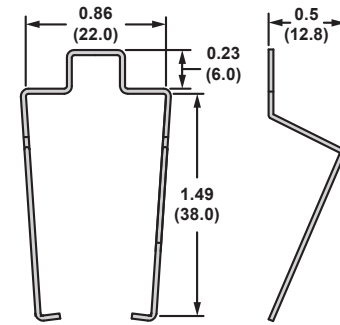

16-783IDC

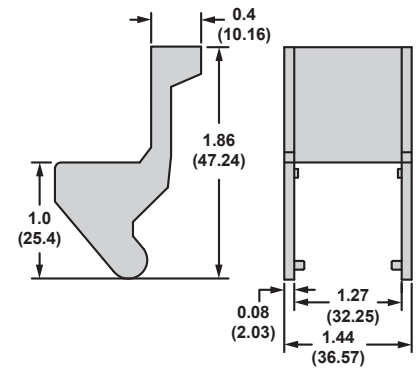

16-783SC

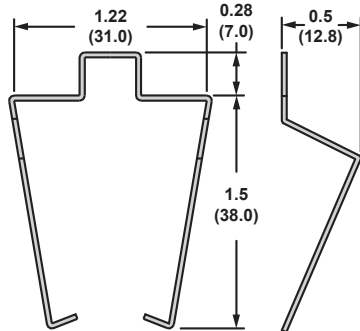

16-784IDC

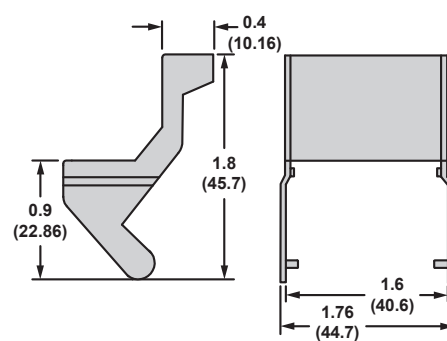

16-784SC

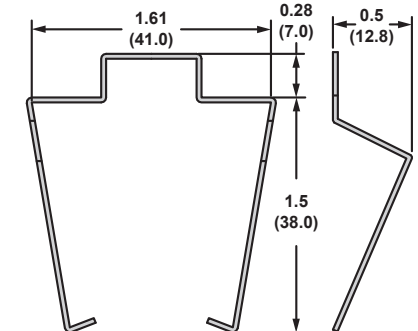

Dimensions

Magnecraft General Purpose Relays

Socket Accessories

Hold-Down Clips

Hold-Down Clip Dimensions (*continued*) — inches (millimeters)

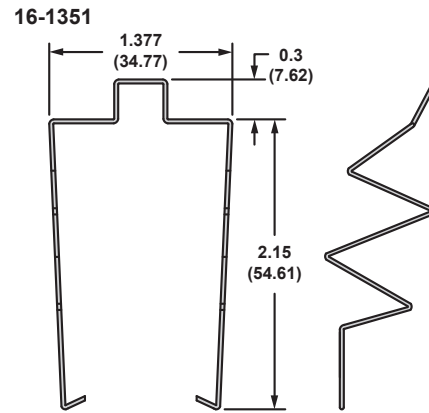
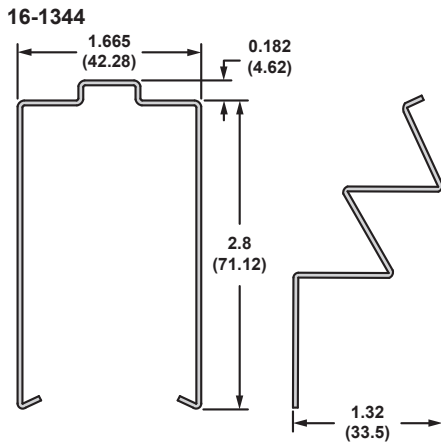
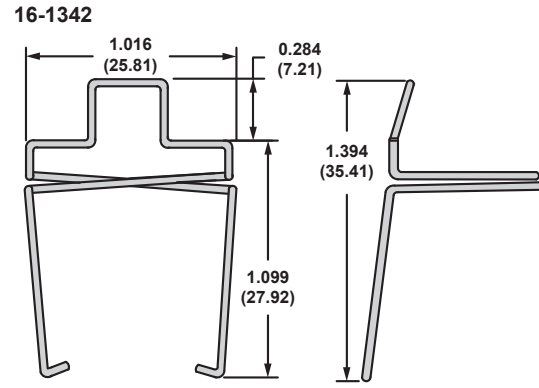
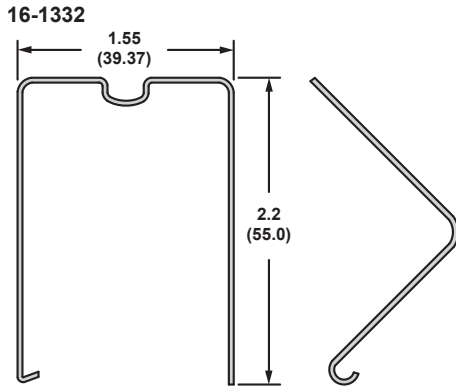

Dimensions

Magnecraft General Purpose Relays

Socket Accessories

Insulated Coil Bus Jumper, DIN Rail and Clip, and ID Tags

Insulated Coil Bus Jumper Dimensions — inches (millimeters)

16-750/788CBJ-1 Coil Bus Jumper

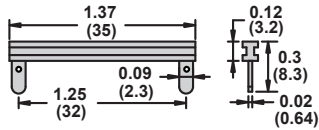

16-750/788CBJ-1 Coil Bus Jumper

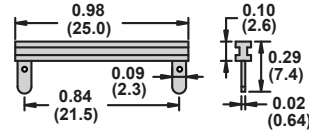

DIN Rail and DIN Clip Dimensions — inches (millimeters)

16-700DIN Metal DIN Rail

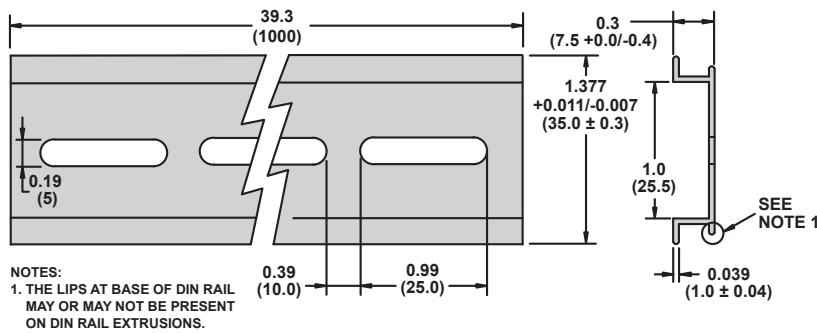

16-DCLIP-1 DIN Rail Clip

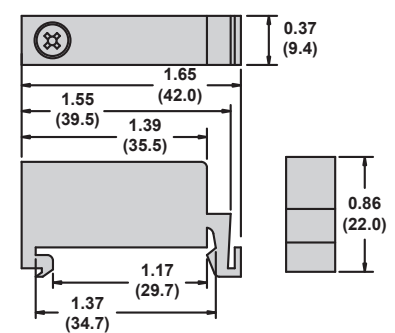

ID Tag Dimensions — inches (millimeters)

16-700ST-1 ID Tag/Label

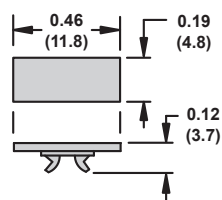

16-750/788FT-1 ID Tag/Label

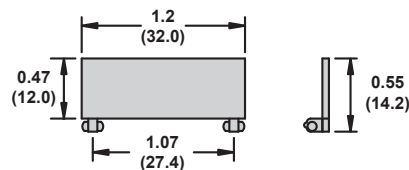

16-782FT-1 ID Tag/Label

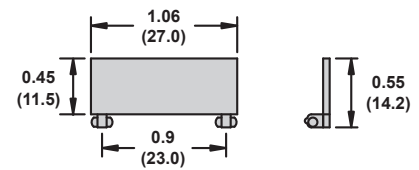

Dimensions

Magnecraft General Purpose Relays

Socket Accessories

Panel Mount Adapter and Socket Modules

Panel Mount Adapter Dimensions — inches (millimeters)

16-788C1 Panel Mount Adapter

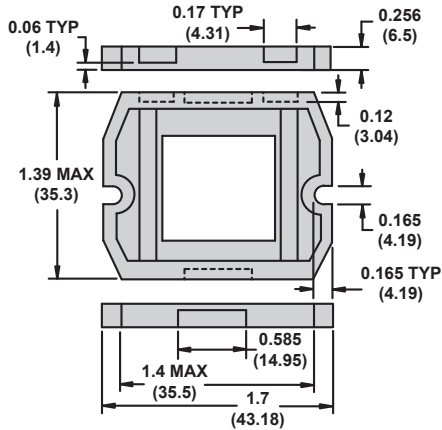

Socket Module Dimensions — inches (millimeters)

70-ASM Socket Modules

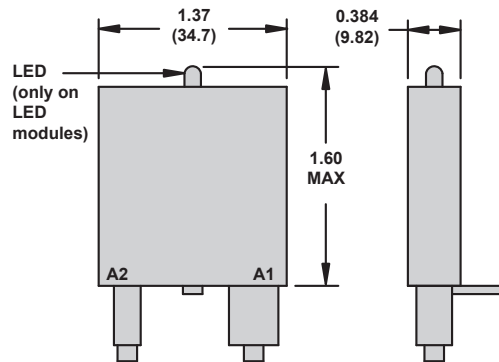

70-BSM Socket Modules

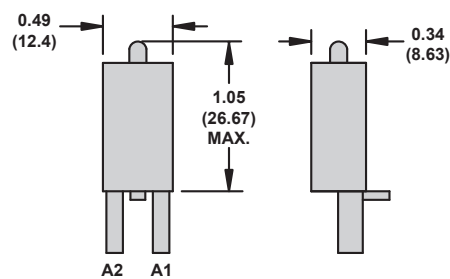

Socket Module Wiring Diagrams

70-ASM & 70-BSM Socket Modules

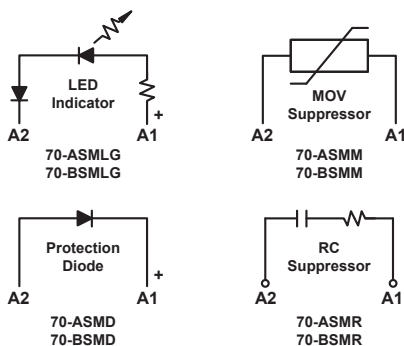

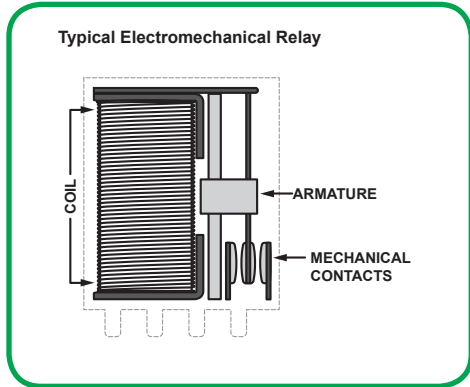

General Purpose Relays

General purpose relays are electromechanical relays which consist of a coil, armature and contacts (see figure at left).

Principle of Operation

When power is applied to the coil, the resulting magnetic field causes the armature to move and the contacts to open or close.

Applications

With multiple options, features and available accessories, Magnecraft general purpose relays offer a complete system solution to improve your design, expedite installation and simplify testing of your application.

Typical Examples of General Purpose Relay Applications

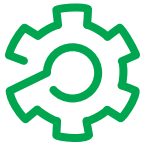

Automation Panels

Process controls, motor controls, standby lighting



Food & Beverage

Commercial/industrial cooking equipment, filtration systems, bottling, chillers, convection ovens



Packaging Machinery

Conveyor motors, food processors, product/shrink wrap, solenoid controls



Lighting Control

Traffic signal systems, motorway information systems, theatrical lighting, ballast lighting



Power Supplies

Universal power supplies, battery backup systems



Material Handling

Motor control, conveyor controls



HVAC & Refrigeration

Anti-condensation equipment, compressor controls, blower controls, motorized duct/vent controls



Appliances

Air conditioners, water heaters, portable heaters, spa controls, water pumps

The Magnecraft website (www.serelays.com) is designed to enable users to easily find the proper relay to fit design requirements and to help simplify and shorten workflow.

Easily find the proper relay to fit design requirements

■ Online Catalog

Find the right product by choosing specifications, compare products side-by-side, and view technical specifications, 2D and 3D drawings, and associated accessories.

■ Cross Reference Search

Search our comprehensive database to identify products by manufacturer and part number, and link directly to part specifications.

■ 3D CAD Library

View, email, download, or insert a file directly into your open CAD software. There are 18 different file formats to choose from.

■ Order Free Samples

Magnecraft offers free samples as a courtesy to individuals and companies evaluating our products for their designs and applications. Sample orders are subject to approval.

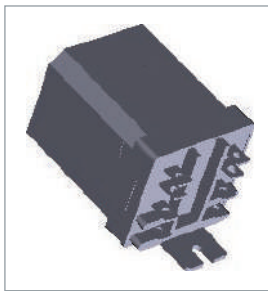

3D Models

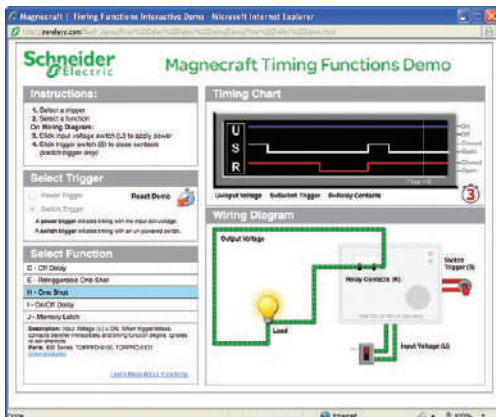

Time Delay Relay Demo

Simplify and shorten workflow

■ Interactive Tools

View interactive demonstrations; such as our Time Delay Relay Interactive Demo (left) which visually demonstrates the ten different timing functions offered on Magnecraft time delay relays.

■ Distributor Inventory Search

Search authorized distributors' current Magnecraft inventory and buy online. (Buy online not available for all distributors).

Magnecraft® Printed Circuit Board & Reed Relays

Catalog
2010

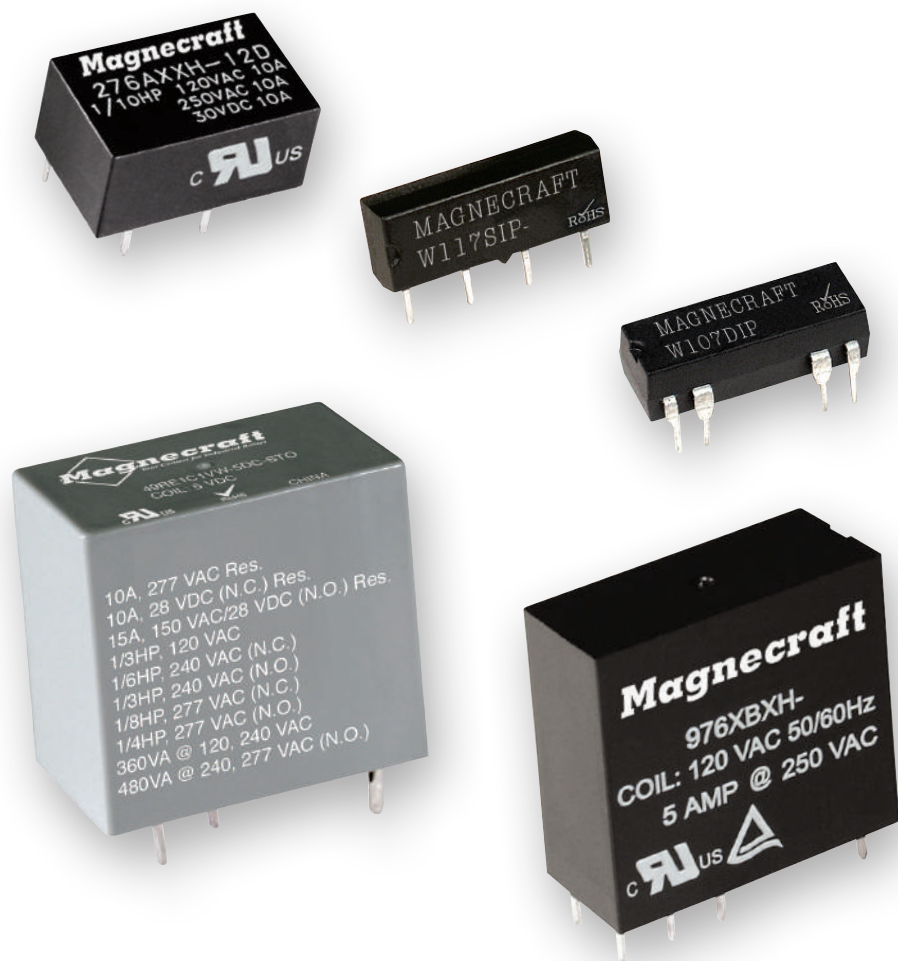

■ Series Overview	3
■ 117SIP Relays	4
■ 107DIP Relays	7
■ 171DIP Relays	10
■ 172DIP Relays	13
■ 49 Series Relays	16
■ 276 Series Relays	19
■ 976 Series Relays	22
■ Application Data	25
■ Selection Guide	27
■ Website Guide	28

Series Overview

Magnecraft® PCB & Reed Relays

Built in small industry-standard packages, the Magnecraft line of printed circuit board (PCB) relays is ideal for a variety of applications.

Key Features

- Space-saving package design
- Single and double pole switching
- Ratings range from 0.25 to 20 A
- Sealed for wash-down process
- Wave solderable



117SIP



107DIP



171DIP



172DIP



49



276



976

Series	Style	Contact Configuration	Output Current Range (A)	Output Voltage Range	Minimum Switching Requirement (mA)	Response Time (ms)	Page
117SIP	Miniature reed relay	SPST	0.25–0.35	120 Vac, 200 Vdc	10	0.45	4
107DIP	Miniature reed relay	SPST	0.25–0.35	120 Vac, 100 Vdc	10	1	7
171DIP	Miniature reed relay	SPST; DPST	0.25–0.35	60–120 Vac, 100 Vdc	10	1	10
172DIP	Miniature reed relay	SPDT; DPDT	0.25–0.35	60 Vac, 100 Vdc	10	1	13
49	Electromechanical relay	SPDT	3–10	120–277 Vac, 28 Vdc	100	25	16
276	Electromechanical relay	SPST; SPDT	7–10	240 Vac, 30 Vdc	100	10	19
976	Electromechanical relay	SPST; DPDT	5–20	240 Vac, 30–48 Vdc	100	10	22

Description

Magnecraft® PCB & Reed Relays

117SIP

SPST, 0.35 A (AC); 0.25 A (DC)

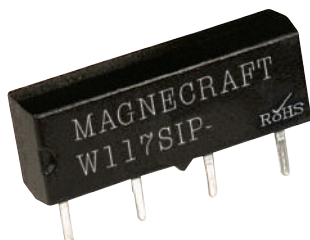

117SIP

Description

The 117SIP reed relays are uniquely designed in a standard style in-line package capable of switching up to 0.35 A (AC); 0.25 A (DC).

Feature	Benefit
Small size	Saves space on a PC board
High shock resistance (50 g-n)	Helps avoid damage in harsh conditions
Industry standard pin spacing	Designed for simple routing on PC board
Can withstand a lead-free solder reflow process	Meets industry standards
RoHS Compliant	Meets industry standards for RoHS compliant reflow processes

Rated Output Current	Contact Configuration	Input Voltage (Vdc)	Coil Resistance (Ω)	Wiring Diagram	Standard Part Number
0.35 A (AC); 0.25 A (DC)	SPST-NO	5	500	A	117SIP-1
		12	1000	A	117SIP-3
	SPST-NC	5	500	B	117SIP-22
	SPST-NO w/clamping diode	5	500	C	117SIP-6
	SPST-NC w/clamping diode	5	500	D	117SIP-18

Part Number Explanation

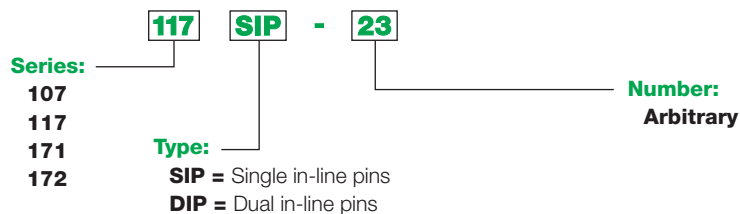

Specifications

Magnecraft® PCB & Reed Relays

117SIP

SPST, 0.35 A (AC); 0.25 A (DC)

Specifications (UL 508)

Part Number 117SIP	Specifications
Input Characteristics	
Input Voltage Range	5–24 Vdc
Operating Range (% of Nominal)	80%–110%
Average Power Consumption	0.29 W
Drop-out Voltage Threshold	10%
Output Characteristics	
Contact Configuration	SPST-NO; SPST-NC
Contact Materials	Ruthenium
Output Current Load	0.35 A (AC); 0.25 A (DC)
Output Voltage Range	120 Vac; 200 Vdc
Output Load Wattage	10 W
Minimum Switching Requirement	1 mA
General Characteristics	
Electrical Life (Operations at rated current)	200,000 operations
Mechanical Life (Unpowered)	1,000,000,000 operations
Operating Time (Response time)	1 ms
Dielectric Strength (Between coil and contact)	500 V(rms)
Dielectric Strength (Between poles)	500 V(rms)
Dielectric Strength (Between contacts)	200 V(rms)
Storage Temperature Range	-40–105 °C (-40–221 °F)
Operating Temperature Range	-40–85 °C (-40–185 °F)
Vibration Resistance (Operational)	20 g-n, 10–2000 Hz
Shock Resistance	50 g-n
Weight	1 g (0.035 oz)
Agency Approvals	RoHS

*Dimensions,
Wiring Diagrams*

Magnecraft® PCB & Reed Relays

117SIP

SPST, 0.35 A (AC); 0.25 A (DC)

Dimensions: Inches (Millimeters)

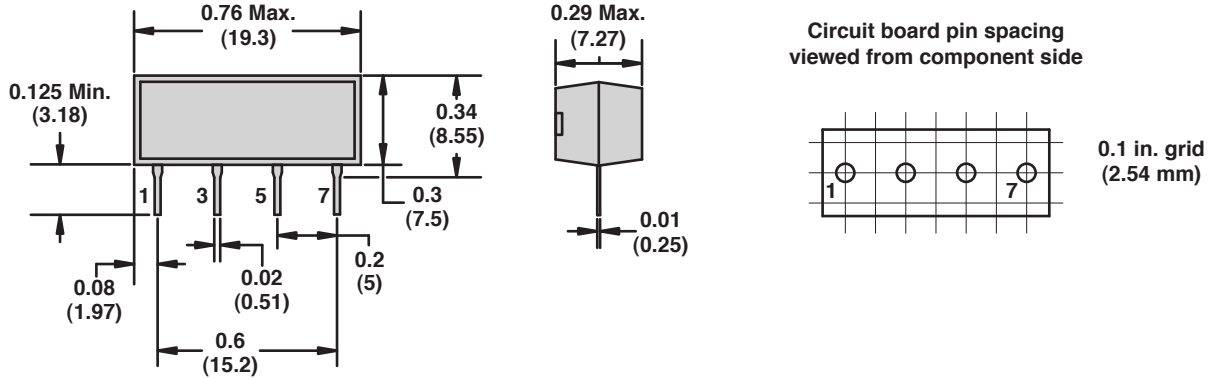

Wiring Diagrams

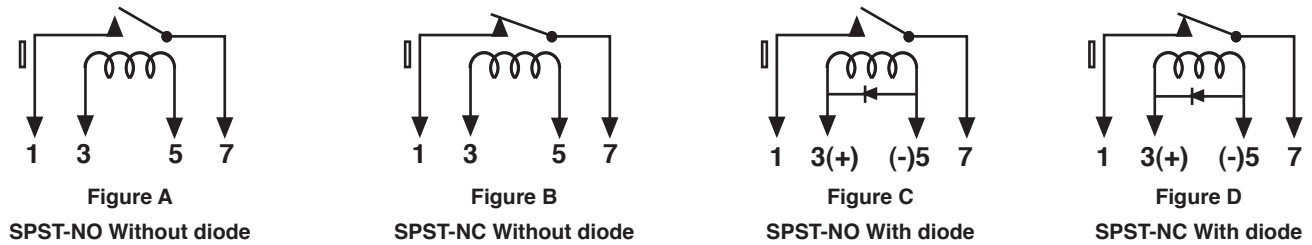

Description

Magnecraft® PCB & Reed Relays

107DIP

SPST-NO, 0.35 A (AC); 0.25 A (DC)

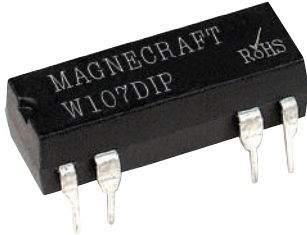

107DIP

Description

The 107DIP reed relays are uniquely designed in a standard style dual in-line package capable of switching up to 0.35 A (AC); 0.25 A (DC).

Feature	Benefit
Small size	Saves space on a PC board
High shock resistance (50 g-n)	Helps avoid damage in harsh conditions
Industry standard pin spacing	Designed for simple routing on PC board
Can withstand a lead-free solder reflow process	Meets industry standards
RoHS Compliant	Meets industry standards for RoHS compliant reflow processes

Rated Output Current	Contact Configuration	Input Voltage (Vdc)	Coil Resistance (Ω)	Wiring Diagram	Standard Part Number
0.35 A (AC); 0.25 A (DC)	SPST-NO	5	500	E	107DIP-1
		12	1000	E	107DIP-3
	SPST-NO w/clamping diode	5	500	F	107DIP-5
		12	1000	F	107DIP-7

Part Number Explanation

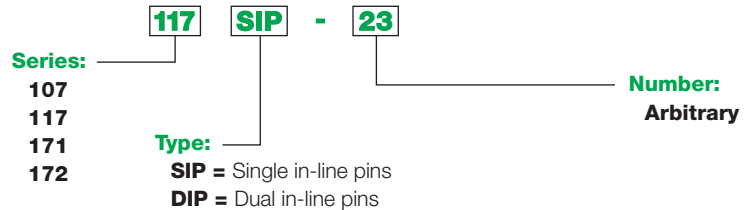

Specifications

Magnecraft® PCB & Reed Relays

107DIP

SPST-NO, 0.35 A (AC); 0.25 A (DC)

Specifications (UL 508)

Part Number 107DIP	Specifications
Input Characteristics	
Input Voltage Range	5–24 Vdc
Operating Range (% of Nominal)	80%–110%
Average Power Consumption	0.29 W
Drop-out Voltage Threshold	10%
Output Characteristics	
Contact Configuration	SPST-NO
Contact Materials	Ruthenium
Output Current Load	0.35 A (AC); 0.25 A (DC)
Output Voltage Range	120 Vac; 100 Vdc
Output Load Wattage	10 W
Minimum Switching Requirement	1 mA
General Characteristics	
Electrical Life (Operations at rated current)	200,000 operations
Mechanical Life (Unpowered)	1,000,000,000 operations
Operating Time (Response time)	1 ms
Dielectric Strength (Between coil and contact)	1000 V(rms)
Dielectric Strength (Between poles)	1000 V(rms)
Dielectric Strength (Between contacts)	200 V(rms)
Storage Temperature Range	-40–105 °C (-40–221 °F)
Operating Temperature Range	-40–85 °C (-40–185 °F)
Vibration Resistance (Operational)	20 g-n, 10–2000 Hz
Shock Resistance	50 g-n
Weight	1 g (0.035 oz)
Agency Approvals	RoHS

*Dimensions,
Wiring Diagrams*

Magnecraft® PCB & Reed Relays

107DIP

SPST-NO, 0.35 A (AC); 0.25 A (DC)

Dimensions: Inches (Millimeters)

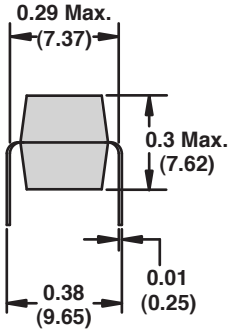
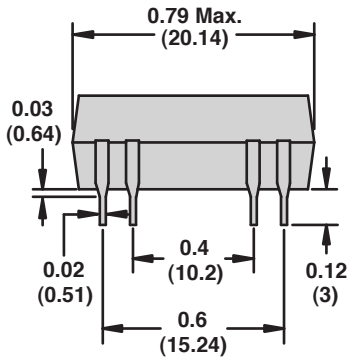

Circuit board pin spacing
viewed from component side

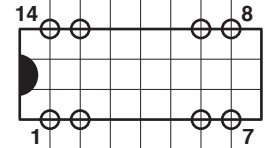

0.1 in. grid
(2.54 mm)

Wiring Diagrams

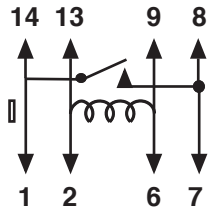

Figure E
SPST-NO Without diode

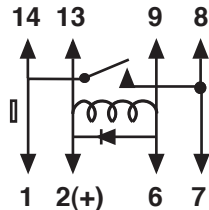

Figure F
SPST-NO With diode

Description

Magnecraft® PCB & Reed Relays

171DIP

SPST, 0.35 A (AC); 0.25 A (DC)

DPST-NO, 0.35 A (AC); 0.25 A (DC)

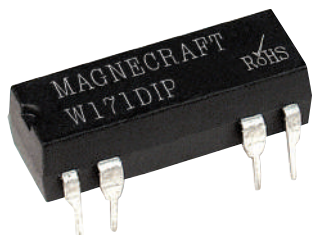

171DIP

Description

The 171DIP reed relays are uniquely designed in a standard style dual in-line package capable of switching up to 0.35 A (AC); 0.25 A (DC).

Feature	Benefit
Small size	Saves space on a PC board
High shock resistance (50 g-n)	Helps avoid damage in harsh conditions
Industry standard pin spacing	Designed for simple routing on PC board
Can withstand a lead-free solder reflow process	Meets industry standards
RoHS Compliant	Meets industry standards for RoHS compliant reflow processes

Rated Output Current	Contact Configuration	Input Voltage (Vdc)	Coil Resistance (Ω)	Wiring Diagram	Standard Part Number
0.35 A (AC); 0.25 A (DC)	SPST-NO	5	500	G	171DIP-2
		12	1000	G	171DIP-4
	SPST-NO w/clamping diode	5	500	H	171DIP-7
		24	2200	H	171DIP-10
	SPST-NC	5	500	I	171DIP-12
		12	1000	I	171DIP-14
	SPST-NC w/clamping diode	5	500	J	171DIP-17
	DPST-NO	5	200	K	171DIP-21
		12	500	K	171DIP-23
	DPST-NO w/clamping diode	5	200	L	171DIP-25
		12	500	L	171DIP-27
			24	2200	L

Part Number Explanation

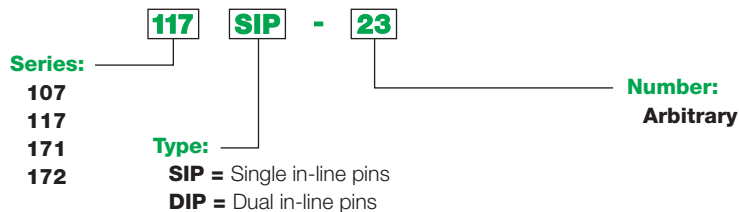

Specifications

Magnecraft® PCB & Reed Relays

171DIP

SPST, 0.35 A (AC); 0.25 A (DC)

DPST-NO, 0.35 A (AC); 0.25 A (DC)

Specifications (UL 508)

Part Number 171DIP	Specifications
Input Characteristics	
Input Voltage Range	5–24 Vdc
Operating Range (% of Nominal)	80%–110%
Average Power Consumption	0.29 W
Drop-out Voltage Threshold	10%
Output Characteristics	
Contact Configuration	SPST-NO; SPST-NC; DPST-NO
Contact Materials	Ruthenium
Output Current Load	0.35 A (AC); 0.25 A (DC)
Output Voltage Range	60 Vac (SPST); 120 Vac (DPST); 100 Vdc
Output Load Wattage	10 W
Minimum Switching Requirement	1 mA
General Characteristics	
Electrical Life (Operations at rated current)	200,000 operations
Mechanical Life (Unpowered)	1,000,000,000 operations
Operating Time (Response time)	1 ms
Dielectric Strength (Between coil and contact)	1000 V(rms)
Dielectric Strength (Between poles)	1000 V(rms)
Dielectric Strength (Between contacts)	200 V(rms)
Storage Temperature Range	-40–105 °C (-40–221 °F)
Operating Temperature Range	-40–85 °C (-40–185 °F)
Vibration Resistance (Operational)	20 g-n, 10–2000 Hz
Shock Resistance	50 g-n
Weight	1 g (0.035 oz)
Agency Approvals	RoHS

*Dimensions,
Wiring Diagrams*

Magnecraft® PCB & Reed Relays

171DIP

SPST, 0.35 A (AC); 0.25 A (DC)

DPST-NO, 0.35 A (AC); 0.25 A (DC)

Dimensions: Inches (Millimeters)

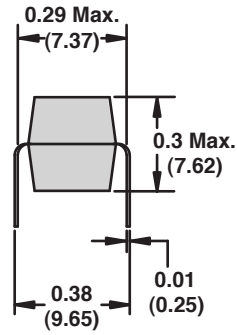
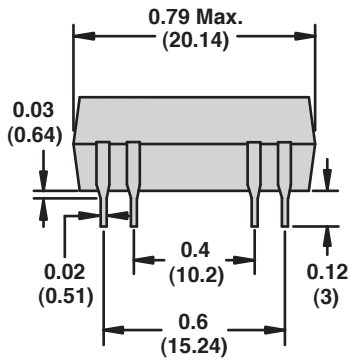

Circuit board pin spacing
viewed from component side

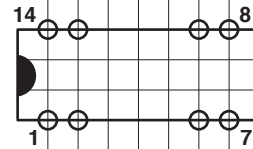

0.1 in. grid
(2.54 mm)

Wiring Diagrams

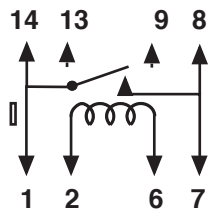

Figure G

SPST-NO Without diode

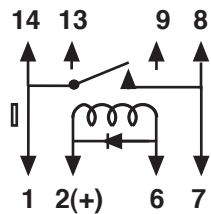

Figure H

SPST-NO With diode

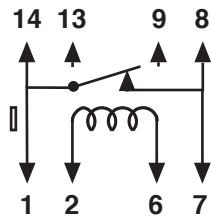

Figure I

SPST-NC Without diode

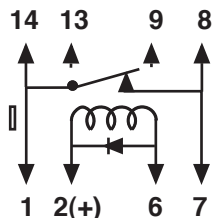

Figure J

SPST-NC With diode

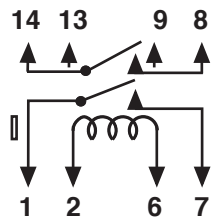

Figure K

DPST-NO Without diode

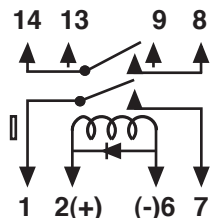

Figure L

DPST-NO With diode

Description

Magnecraft® PCB & Reed Relays

172DIP

SPDT, 0.35 A (AC); 0.25 A (DC)

DPDT, 0.35 A (AC); 0.25 A (DC)

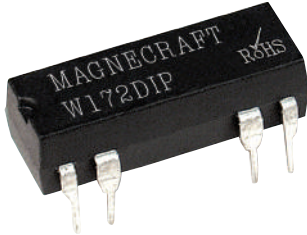

172DIP

Description

The 172DIP reed relays are uniquely designed in a standard style dual in-line package capable of switching up to 0.35 A (AC); 0.25 A (DC).

Feature	Benefit
Small size	Saves space on a PC board
High shock resistance (50 g-n)	Helps avoid damage in harsh conditions
Industry standard pin spacing	Designed for simple routing on PC board
Can withstand a lead-free solder reflow process	Meets industry standards
RoHS Compliant	Meets industry standards for RoHS compliant reflow processes

Rated Output Current	Contact Configuration	Input Voltage (Vdc)	Coil Resistance (Ω)	Wiring Diagram	Standard Part Number
0.35 A (AC); 0.25 A (DC)	SPDT	5	200	M	172DIP-1
				O	172DIP-31
				P	172DIP-141
		12	1000	M	172DIP-3
				O	172DIP-33
				P	172DIP-145
	SPDT w/clamping diode	5	200	N	172DIP-5
				Q	172DIP-147
		12	1000	N	172DIP-7
				Q	172DIP-149
		24	2200	N	172DIP-8
				Q	172DIP-150
DPDT	12	266	R	172DIP-19	
DPDT w/clamping diode	5	46	S	172DIP-21	
	12	266	S	172DIP-23	

Part Number Explanation

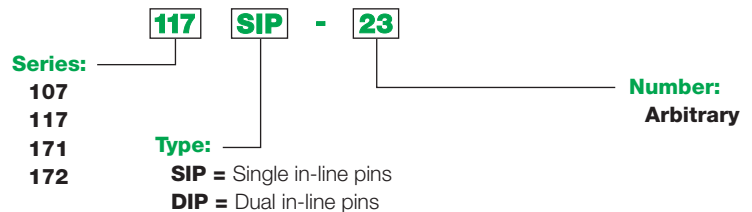

Specifications

Magnecraft® PCB & Reed Relays

172DIP

SPDT, 0.35 A (AC); 0.25 A (DC)

DPDT, 0.35 A (AC); 0.25 A (DC)

Specifications (UL 508)

Part Number 172DIP	Specifications
Input Characteristics	
Input Voltage Range	5–24 Vdc
Operating Range (% of Nominal)	80%–110%
Average Power Consumption	0.29 W
Drop-out Voltage Threshold	10%
Output Characteristics	
Contact Configuration	SPDT; DPDT
Contact Materials	Ruthenium
Output Current Load	0.35 A (AC); 0.25 A (DC)
Output Voltage Range	60 Vac; 100 Vdc
Output Load Wattage	5 W
Minimum Switching Requirement	1 mA
General Characteristics	
Electrical Life (Operations at rated current)	200,000 operations
Mechanical Life (Unpowered)	1,000,000,000 operations
Operating Time (Response time)	1 ms
Dielectric Strength (Between coil and contact)	1000 V(rms)
Dielectric Strength (Between poles)	1000 V(rms)
Dielectric Strength (Between contacts)	150 V(rms)
Storage Temperature Range	-40–105 °C (-40–221 °F)
Operating Temperature Range	-40–85 °C (-40–185 °F)
Vibration Resistance (Operational)	20 g-n, 10–2000 Hz
Shock Resistance	50 g-n
Weight	1 g (0.035 oz)
Agency Approvals	RoHS

Dimensions, Wiring Diagrams

Magnecraft® PCB & Reed Relays

172DIP

SPDT, 0.35 A (AC); 0.25 A (DC)

DPDT, 0.35 A (AC); 0.25 A (DC)

Dimensions: Inches (Millimeters)

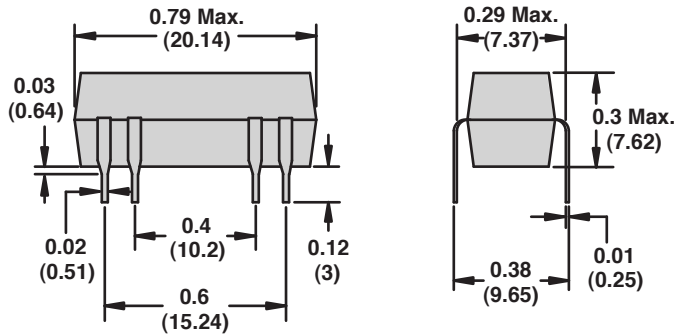

Circuit board pin spacing
viewed from component side

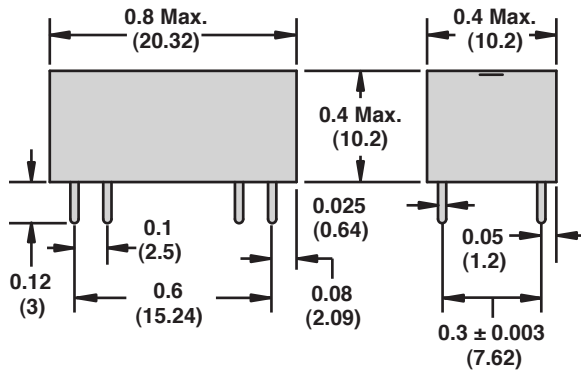
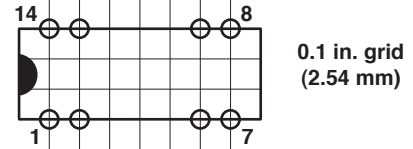

Wiring Diagrams

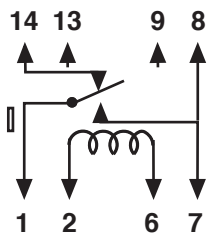

Figure M
SPDT Without diode

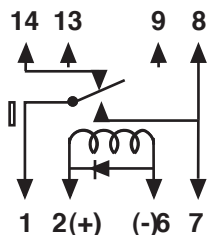

Figure N
SPDT With diode

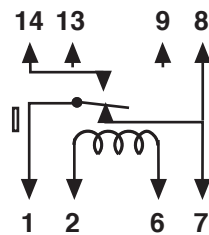

Figure O
SPDT Without diode

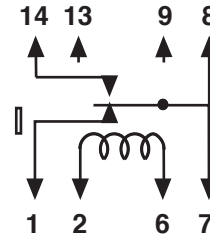

Figure P
SPDT Without diode

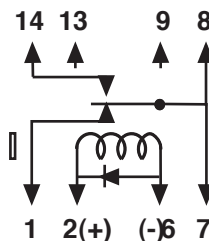

Figure Q
With diode

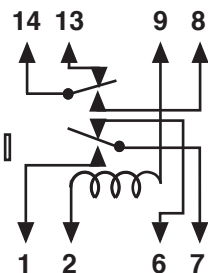

Figure R
DPDT Without diode

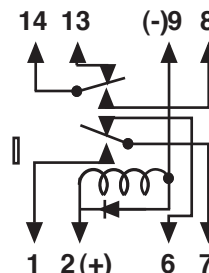

Figure S
DPDT With diode

Description

Magnecraft® PCB & Reed Relays

49

SPDT, 3 to 10 A

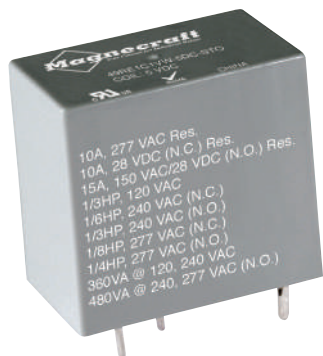

49

Description

The 49 series enclosed printed circuit board relays are used to switch resistive and inductive loads in industrial applications.

Feature	Benefit
Small size	Enables relay to be used in smaller applications by saving space on PC board
Rated up to 10 A	Higher switching capacity expands range of potential applications
TV3 rating	Makes it ideal for appliance use
Tungsten, ballast and motor ratings (10 A version only)	Approved for use with inductive loads
Multiple footprint configurations	Fits a variety of applications and increases functionality and ease of use

Rated Output Current (A)	Contact Configuration	Input Voltage (Vdc)	Coil Resistance (Ω)	Style	Standard Part Number
3	SPDT	3	90	Narrow footprint	49RE1C1VG-3DC-SIL
		5	235	Narrow footprint	49RE1C1VG-5DC-SIL
		12	1350	Narrow footprint	49RE1C1VG-12DC-SIL
			1640	Wide footprint	49RE1C2VF-12DC-SIL
5	SPDT	5	235	Narrow footprint	49RE1C1VG-5DC-STO
		6	410	Wide footprint	49RE1C2VF-6DC-STO
		12	1350	Narrow footprint	49RE1C1VG-12DC-STO
		18	3000	Narrow footprint	49RE1C1VG-18DC-STO
		24	5400	Narrow footprint	49RE1C1VG-24DC-STO
10	SPDT	5	235	Narrow footprint with top mounting bracket	49R1C4VG-5DC-STO
		5	100	Narrow footprint	49RE1C1VW-5DC-STO
		12	600	Narrow footprint	49RE1C1VW-12DC-STO
		24	2400	Narrow footprint	49RE1C1VW-24DC-STO

Part Number Explanation

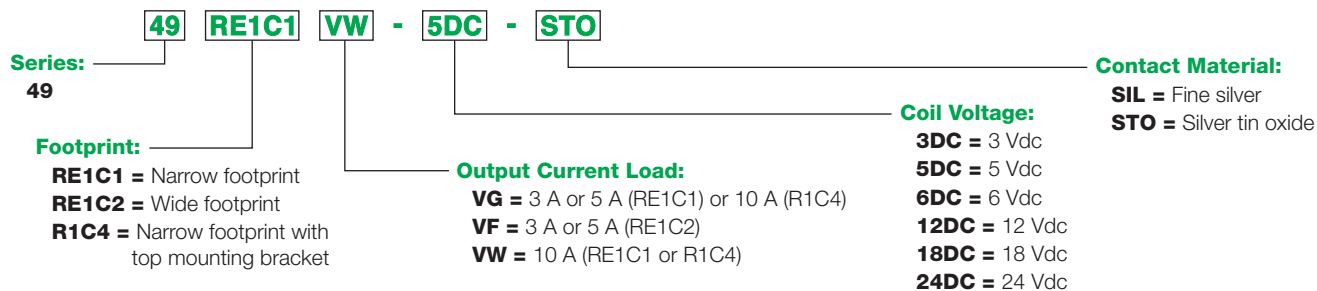

Specifications

Magnecraft® PCB & Reed Relays

49

SPDT, 3 to 10 A

Specifications (UL 508)

Part Number	49 Relay 3 A	49 Relay 5 A	49 Relay 10 A	
Input Characteristics				
Input Voltage Range	NO: 3–24 Vdc; NC: 5–24 Vdc	3–24 Vdc		
Operating Range (% of Nominal)	75%–110%			
Average Power Consumption	0.11 W			
Drop-out Voltage Threshold	10%			
Output Characteristics				
Contact Configuration	SPDT			
Contact Materials	Fine Silver	Silver Tin Oxide		
Contact Ratings	General Purpose	3 A @ 120 Vac	5 A @ 120 Vac	10 A @ 240 Vac
	Resistive	NO: 15 A @ 150 Vac 50/60 Hz, 15 A @ 28 Vdc; NC: 3 A @ 28 Vdc	NO/NC: 5 A @ 28 Vdc	NO: 15 A @ 150 Vac 50/60 Hz, 15 A @ 28 Vdc; NC: 10 A @ 277 Vac 50/60 Hz, 10 A @ 28 Vdc
	Motor	N/A	N/A	NO: 1/3 hp @ 120/240 Vac, 1/4 hp @ 277 Vac; NC: 1/3 hp @ 120 Vac, 1/6 hp @ 240 Vac, 1/8 hp @ 277 Vac
	Tungsten	N/A	N/A	NC: 2 A @ 120 Vac
	Ballast	N/A	N/A	NO/NC: 1.7 A @ 277 Vac
	TV-3	N/A	N/A	120 Vac
	Pilot Duty	N/A	B300: 360 VA @ 120/240 Vac	B300: 360 VA @ 120/240 Vac; 480 VA @ 240/277 Vac (NO)
Minimum Switching Requirement	100 mA			
General Characteristics				
Electrical Life (Operations @ rated current)	100,000 operations			
Mechanical Life (Unpowered)	10,000,000 operations			
Response Time	25 ms			
Dielectric Strength (Between coil and contact)	2500 V(rms)	2500 V(rms)	1500 V(rms)	
Dielectric Strength (Between contacts)	500 V(rms)	500 V(rms)	500 V(rms)	
Storage Temperature Range	-40–85 °C (-40–185 °F)			
Operating Temperature Range	-40–55 °C (-40–131 °F)			
Vibration Resistance (Operational)	3 g-n, 10–55 Hz			
Shock Resistance	10 g-n			
Weight	42 g (1.48 oz)			
Available Footprint Styles	RE1C1 & RE1C2	RE1C1, RE1C2 & R1C4	RE1C1 & R1C4	
Agency Approvals	UR (E258297), RoHS			

Dimensions, Wiring Diagrams

Magnecraft® PCB & Reed Relays

49

SPDT, 3 to 10 A

Dimensions: Inches (Millimeters)

Narrow footprint style (RE1C1)

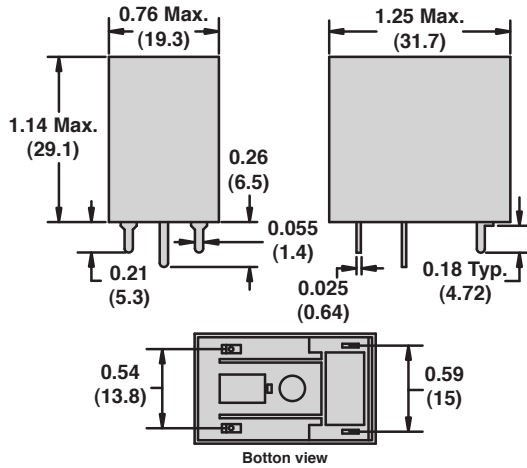

Wide footprint style (RE1C2)

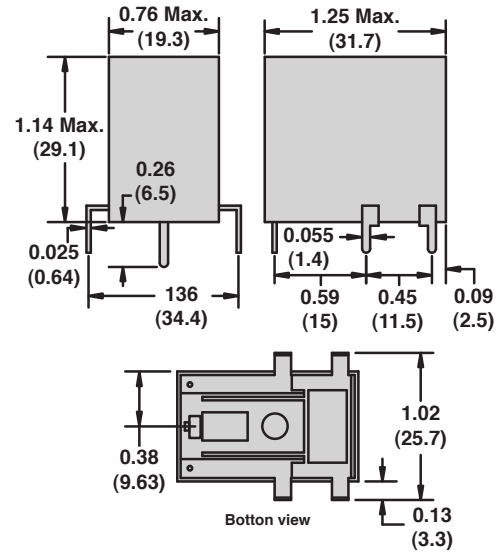

Top mounting bracket style (R1C4)

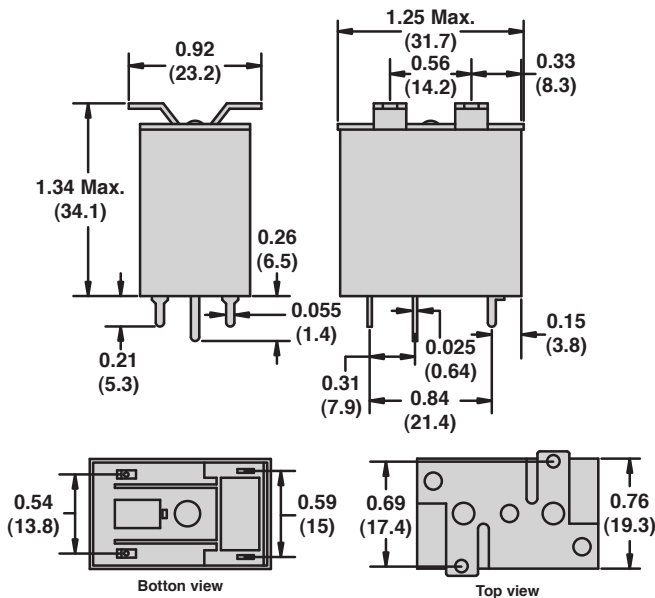

Circuit board pin spacing
viewed from component side on PCB board

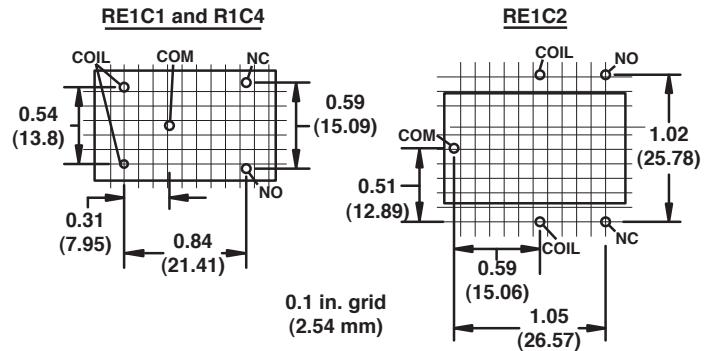

Wiring Diagrams

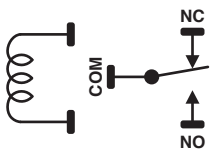

Style RE1C1 & R1C4

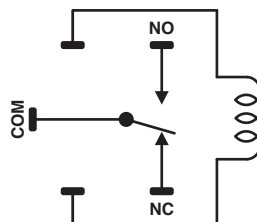

Style RE1C2

Description

Magnecraft® PCB & Reed Relays

276

SPST, 10 A

SPDT, 7 A

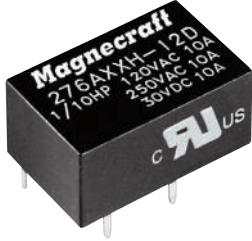

276

Description

The 276 series relays offer high switching capacity in a small package.

Feature	Benefit
High current switching capacity	Enables the relay to switch up to 10 A
HP rated	UL approved to switch up to 1/10 hp
Low-profile design	Uses less than 12.7 mm ² (0.5 in ²) of space on a PC board
Small footprint	Saves valuable space on a printed circuit board
Epoxy sealed	Allows the relay to be washed after assembly

Rated Output Load (A)	Contact Configuration	Input Voltage (Vdc)	Coil Resistance (Ω)	Standard Part Number
7	SPDT	5	125	276XAXH-5D
		12	720	276XAXH-12D
		24	2880	276XAXH-24D
10	SPST-NO	5	125	276AXXH-5D
		12	720	276AXXH-12D

Part Number Explanation

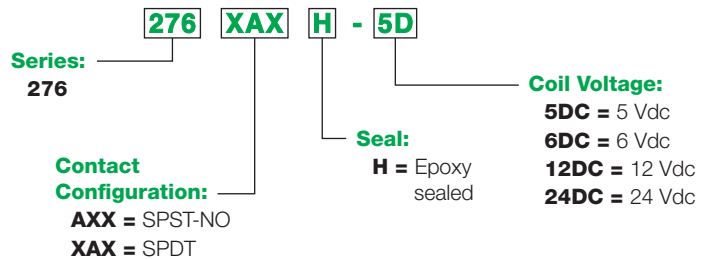

Specifications

Magnecraft® PCB & Reed Relays

276

SPST, 10 A

SPDT, 7 A

Specifications (UL 508)

Part Number	276XAX	276AXX
Input Characteristics		
Input Voltage Range	3–24 Vdc	
Operating Range (% of Nominal)	80%–110%	
Average Power Consumption	0.2 W	
Drop-out Voltage Threshold	10%	
Output Characteristics		
Contact Configuration	SPDT	SPST-NO
Contact Materials	Silver Alloy	
Output Current Load	7 A	10 A
Maximum Output Voltage	7 A @ 240 Vac 50/60 Hz; 7 A @ 30 Vdc; 1/10 hp @ 120 Vac	10 A @ 240 Vac 50/60 Hz; 10 A @ 30 Vdc; 1/6 hp @ 120 Vac
Minimum Switching Requirement	100 mA	
General Characteristics		
Electrical Life (Operations at rated current)	100,000 operations	
Mechanical Life (Unpowered)	5,000,000 operations	
Operating Time (Response time)	10 ms	
Dielectric Strength (Between coil and contact)	2000 Vac	
Dielectric Strength (Between contacts)	1000 Vac	
Storage Temperature Range	–40–85 °C (–40–185 °F)	
Operating Temperature Range	–40–70 °C (–40–158 °F)	
Vibration Resistance (Operational)	1.5 g-n, 10–55 Hz	
Shock Resistance	20 g-n	
Weight	5.5 g (0.19 oz)	
Agency Approvals	UR (E43641), RoHS	

*Dimensions,
Wiring Diagrams*

Magnecraft® PCB & Reed Relays

276
SPST, 10 A
SPDT, 7 A

Dimensions: Inches (Millimeters)

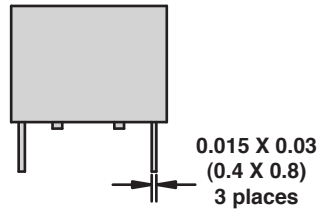
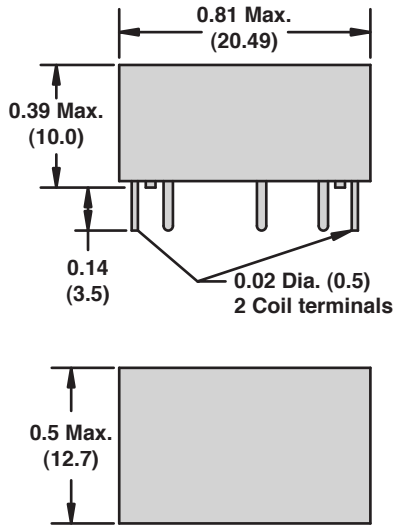

Circuit board pin spacing viewed from component side

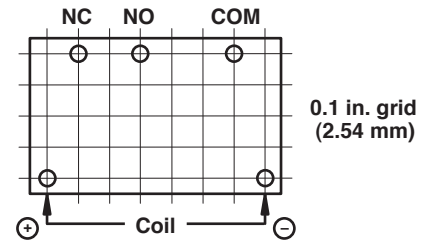

Wiring Diagrams

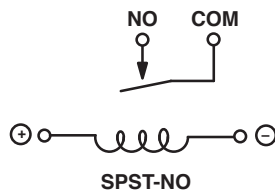
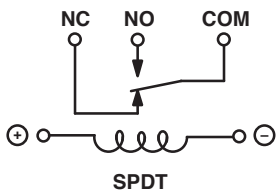

Description

Magnecraft® PCB & Reed Relays

976

SPDT, 12 to 20 A

DPDT, 5 A



976

Description

The 976 series enclosed printed circuit board relays are used to switch resistive and inductive loads in industrial applications.

Feature	Benefit
High current switching capacity	Enables the relay to switch up to 20 A
AC coil voltages available	Expands application use
8 mm coil to contact clearance	Meets international standards
Epoxy sealed	Allows the relay to be washed after assembly

Rated Output Current (A)	Contact Configuration	Input Voltage	Coil Resistance (Ω)	Standard Part Number
5	DPDT	12 Vdc	270	976XBXH-12D
		24 Vac 50/60 Hz	250	976XBXH-24A
		24 Vdc	1100	976XBXH-24D
		120 Vac 50/60 Hz	5600	976XBXH-120A
		240 Vac 50/60 Hz	22000	976XBXH-240A
12	SPDT	24 Vac 50/60 Hz	250	976XAXH-24A
		24 Vdc	1100	976XAXH-24D
		120 Vac 50/60 Hz	5600	976XAXH-120A
		240 Vac 50/60 Hz	22000	976XAXH-240A
20	SPDT	24 Vac 50/60 Hz	250	976XAX97H-24A
		24 Vdc	1100	976XAX97H-24D
		120 Vac 50/60 Hz	5600	976XAX97H-120A

Part Number Explanation

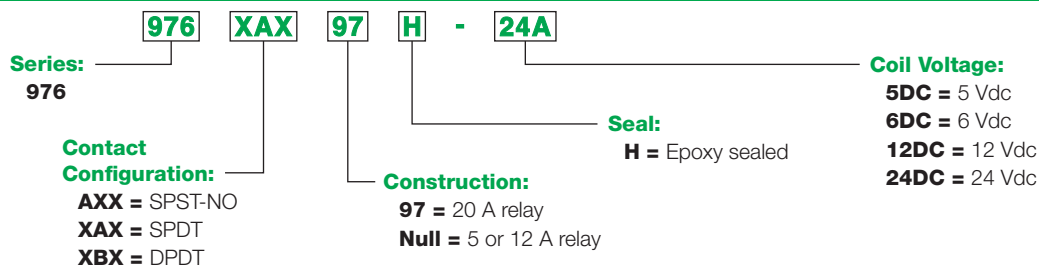

Specifications

Magnecraft® PCB & Reed Relays

976

SPDT, 12 to 20 A

DPDT, 5 A

Specifications (UL 508)

Part Number	976XAX97H	976XAXH	976XBXH
Input Characteristics			
Input Voltage Range	6–240 Vac; 3–110 Vdc		
Operating Range (% of Nominal)	85%–110%		
Average Consumption	1.2 VA; 0.53 W		
Drop-out Voltage Threshold	30% AC; 10% DC		
Output Characteristics			
Contact Configuration	SPDT	SPDT	DPDT
Contact Materials	Silver Alloy		
Output Current Load	20 A	12 A	5 A
Maximum Switching Voltage	300 V		
Output Voltage Range	20 A @ 125 Vac 50/60 Hz; 16 A @ Vac 50/60 Hz; 20 A @ 30 Vdc; 10 A @ 48 Vdc	NO: 12 A @ 240 vac 50/60 Hz, 12 A @ 30 Vdc; NC: 10 A @ 240 Vac 50/60 Hz, 10 A @ 30 Vdc	5 A @ 240 Vac 50/60 Hz; 5 A @ 30 Vdc
General Characteristics			
Electrical Life (Operations at Rated Current)	100,000 operations		
Mechanical Life (Unpowered)	10,000,000 operations		
Operating Time (Response time)	15 ms		
Dielectric Strength (Between coil and contact)	5000 V(rms)		
Dielectric Strength (Between contacts)	1000 V(rms)		
Storage Temperature Range	-40–85 °C (-40–185 °F)		
Operating Temperature Range	-40–55 °C (-40–131 °F)		
Vibration Resistance (Operational)	3 g-n, 10-55 Hz		
Shock Resistance	10 g-n		
Weight	17 g (0.6 oz)		
Agency Approvals	UR (E191122), TUV, RoHS		

*Dimensions,
Wiring Diagrams*

Magnecraft® PCB & Reed Relays

976
SPDT, 12 to 20 A
DPDT, 5 A

Dimensions: Inches (Millimeters)

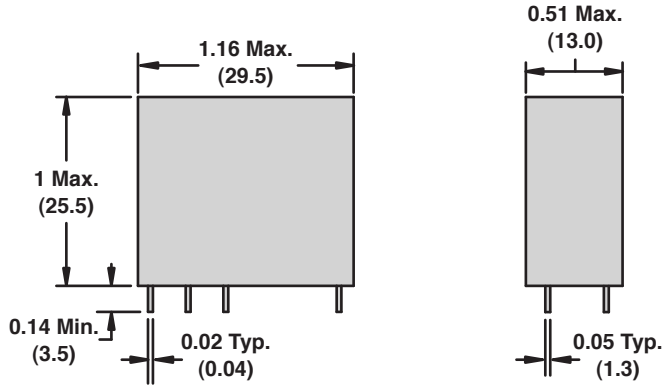

Circuit board pin spacing viewed from component side

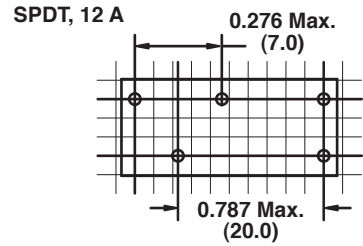

0.1 in. grid
(2.54 mm)

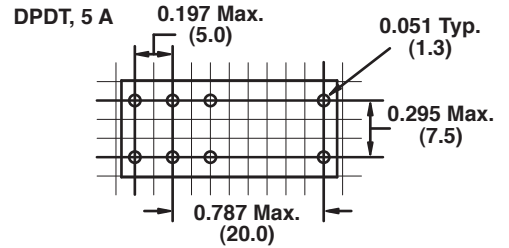
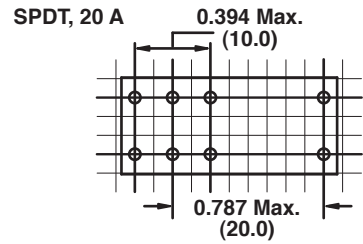

Wiring Diagrams

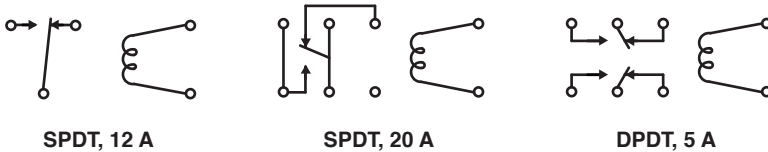

Introduction

Printed circuit board (PCB) relays are compact relay devices used for power management in control system designs which require the relay to be mounted directly on the printed circuit board. They are used in applications where the relay must be small enough to be mounted on a printed circuit board. They must be easy to manufacture with the same machinery used in the printed circuit board line.

How Electromechanical PCB Relays Work

Electromechanical PCB relays consist of a coil, armature and contacts (see figure below). When power is applied to the coil, the resulting magnetic field causes the armature to move and the contacts to open or close.

Advantages

- Higher contact ratings than reed relays and smaller than traditional plug-in relays
- A wider range of form, fit and function than reed relays
- UL recognized to meet industry standards for product safety and compliance

How Reed Relays Work

Reed relays consist of a coil wrapped around a sealed glass tube containing the reeds and contacts (see figure below). When power is applied to the coil, the resulting magnetic field causes the reeds to move and the contacts to close (1).

Advantages

- Highly reliable due to longer mechanical and electrical life than electromechanical relays
- Can switch about ten times faster than an electromechanical relay with similar ratings
- Small, industry standard packaging which does not require unique machinery to populate

Electromechanical PCB Relays vs. Reed Relays

Typical Electromechanical PCB Relay

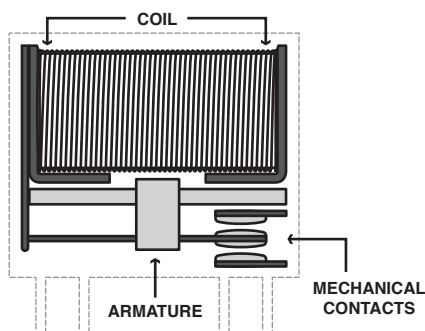

Typical Reed Relay

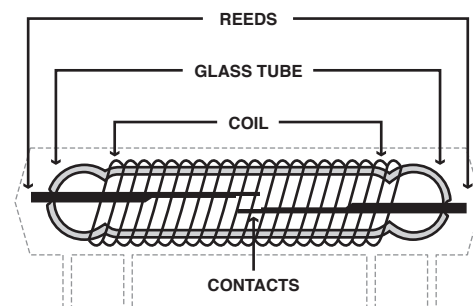

(1) Note that it is important to keep reed relays at a proper distance from each other because of the possibility of magnetic-interaction between them. Proper magnetic shielding must be used to contain stray magnetic fields. When installing reed relays into equipment, be aware of the devices in the equipment which can produce magnetic fields. Position the relays as far away as possible from any stray magnetic fields, and shield them to prevent false operations. A general rule is to space reed relays no closer together than 0.5 inches.

Applications

The Magnecraft PCB relay offer consists of reed relays ideal for applications requiring fast, reliable low-level switching capability in a very small package, and electromechanical PCB relays ideal for applications requiring higher ratings than reed relays and a smaller package than traditional plug-in relays.

Typical Examples of PCB and Reed Relay Applications



Automotive

Anti-lock brake systems, cruise control, doors, power steering, power windows, sunroofs



Electronics & Communication

Cellular phones, computers, copiers, microphones, radio transmitters, speakers

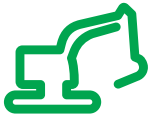

Construction & Security

Conveyor belts, elevators, emergency lamps, hoists, lifts, security alarms



HVAC & Refrigeration

Air conditioners, blowers, compressors, motorized ducts/vents, refrigerators, space heaters



Domestic Appliances

Coffee machines, dish washers, food processors, microwaves, ovens, stoves, vacuum cleaners, washing machines

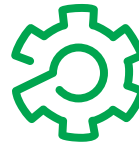

Industrial Automation

Human/machine interfaces, motion controllers, PLCs, power supplies, solder/wave reflow systems, variable speed drives

The Magnecraft Range of Printed Circuit Board and Reed Relays

Printed circuit board and reed relays are compact devices used for high power and low level applications that require printed circuit board assembly.

Selecting a Printed Circuit Board or Reed Relay

The list below is an example of the specifications to look for when selecting a printed circuit board or reed relay.

Input voltage:	_____
Coil resistance:	_____
Contact rating:	_____
Contact configuration:	_____
Mounting style:	_____

Use the catalog specifications or online parametric search to determine a recommended part number (www.magnecraft.com).

The Magnecraft website (www.magnecraft.com) was designed to enable users to easily find the proper relay to fit design requirements and to help simplify and shorten workflow.

Easily find the proper relay to fit design requirements

■ Online Catalog

Find the right product by choosing specifications compare products side-by-side and view technical specifications, 2D and 3D drawings and associated accessories.

■ Cross Reference Search

Search our comprehensive database to identify by manufacturer and part number, and link directly to part specifications.

■ 3D CAD Library

View, email, download or insert a file directly into your open CAD software pane and select from 18 different file formats.

■ Order Free Samples

Magnecraft offers free samples as a courtesy to individuals and companies evaluating our products in their designs and applications. Sample orders are subject to approval.

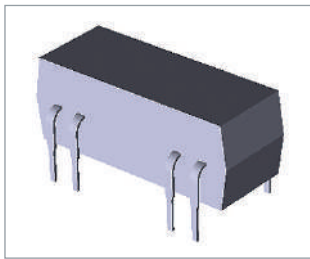

3D Models

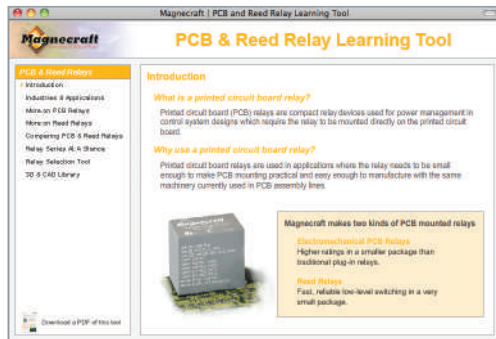

PCB & Reed Relay Learning Tool

Simplify and shorten workflow

■ Interactive Tools

View interactive learning tools such as our PCB & Reed Relay Learning Tool which helps you learn more about Magnecraft's electromechanical PCB relays and reed relays, including industries and applications, principles of operation and advantages of using each type of relay.

■ Distributor Inventory Search

Search authorized distributors' current Magnecraft inventory and buy online. (Buy online not available for all distributors).