

Fuji, fujitsu, Минск +375447584780

www.fotorele.net www.tiristor.by радиодетали, электронные компоненты
email minsk17@tut.by tel.+375 29 758 47 80 МТС

каталог, описание, технические, характеристики, datasheet, параметры,
маркировка, габариты, фото, модуль, Fuji, fujitsu, реле

КАТАЛОГ

модуль , igbt, мост диодный, реле

купить, продажа

электронные компоненты

Мы не работаем с частными (физическими) лицами. Мы работаем только с юридическими
лицами(организациями) и ИП и только по безналичному расчёту.

[где и как купить в Минске?](#)



FUJI SEMICONDUCTORS

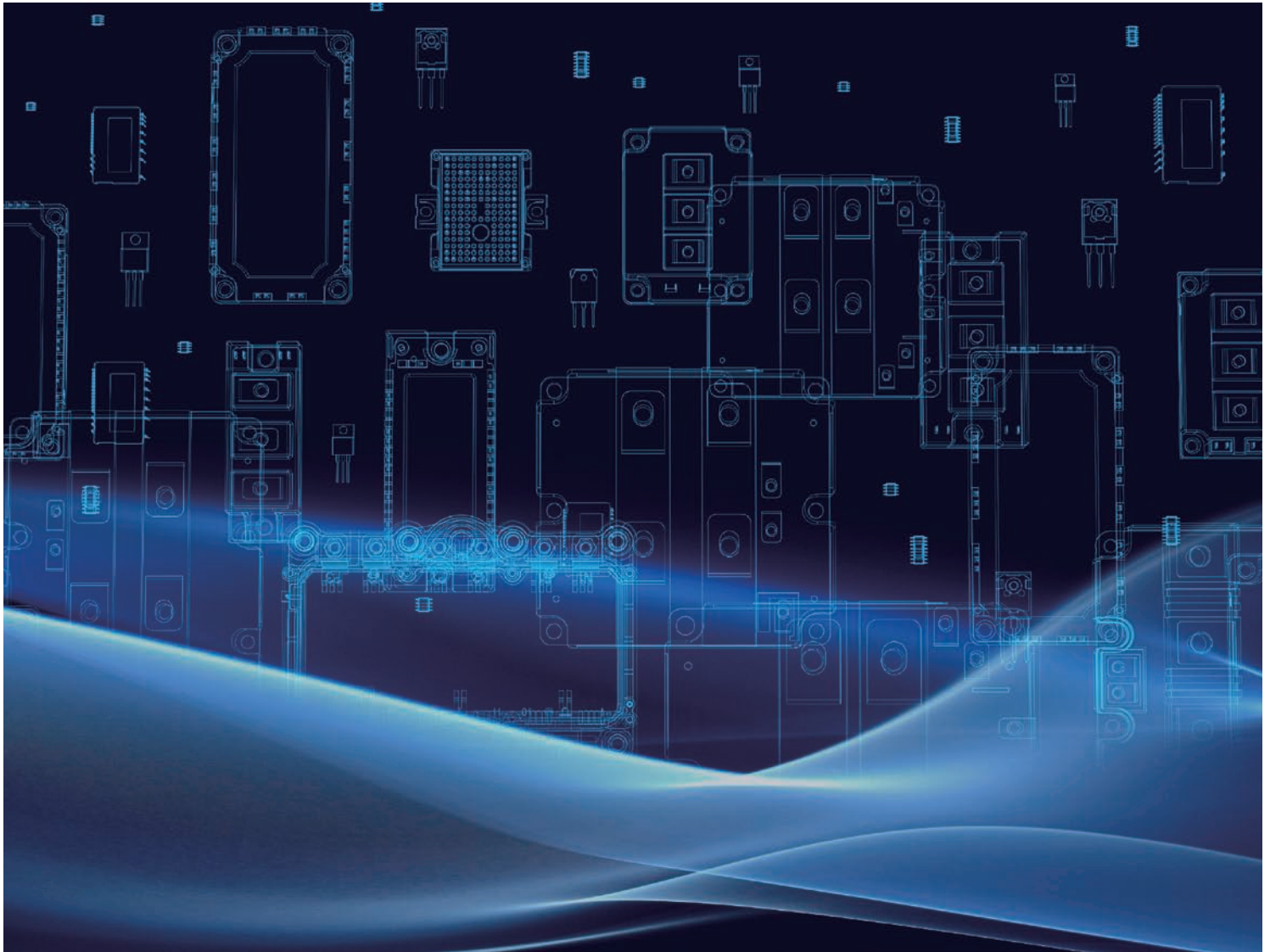

Supporting Society with
Energy and Environmental Technology



Fuji Electric Power Semiconductors contributing Energy Management in various fields

Fuji Electric provides Power Semiconductors enabling high-efficiency energy usage in various fields such as industrial machinery, automobile, railroad, social infrastructure, renewable energy, consumer electronics and information equipment in order to achieve low-carbon society.

Fuji Electric contributes to realization of safe and secure sustainable society through continuous technology innovation and product development of Power Semiconductors as key devices in Power Electronics technology.

The pictures on this page show examples of various applications which may use Fuji Electric Power Semiconductors, they aren't necessarily used in the products in these pictures.

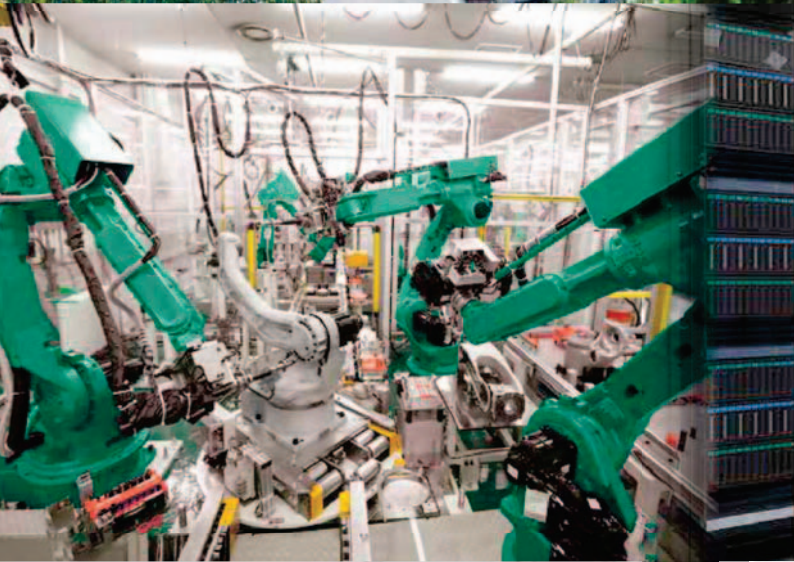



Renewable energy



Public transportation



Industry



Consumer

01

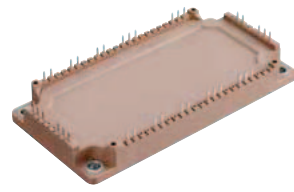

Power Devices
(IGBT)
----- P6

02

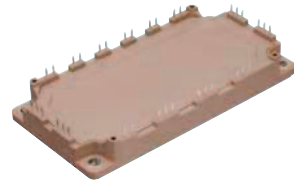

SiC Devices
----- P50

03



Integrated Circuits
----- P57

04

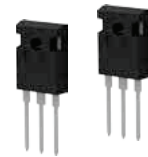

Power MOSFETs
----- P70

05

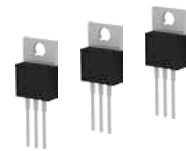

Rectifier Diodes
----- P96

06



Pressure Sensors
----- P111

INDEX

Outline	-----	P112
Order Quantity	-----	P131
Number Index	-----	P132
Maintenance products	-----	P137
Discontinued products	-----	P139
Warning	-----	P141

Fuji Electric provides Power Semiconductors well suited for various applications. You will find more information on products for each application shown below at our Web site.

www.fujielectric.com/products/semiconductor/usage/

Inverters

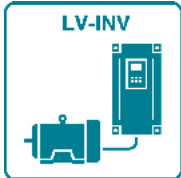

Semiconductor products best suited for general-purpose inverters that carry out variable-speed operation of motors in products such as belt conveyors, fans and pumps

Medium-Voltage Inverters

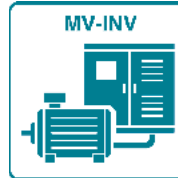

Semiconductor products suitable for medium-voltage inverters that drive 3-phase AC 3k/6k/6.6kV high-voltage motors used in iron and steel plants, textile plants and paper mills

NC / Servos



Semiconductor products best suited to NC and servos that carry out speed control and positioning of machine tools, as well as robots that have multi-spindle control features used in assembly, welding and conveyance

Railroads



Semiconductor products suited for the power electronics of railroad cars such as the main motor drive and auxiliary power supply equipment of rolling stock

Wind Power Generation



Semiconductor products suitable for AC/DC converters that convert the AC power output from wind turbine generators to DC power, as well as for inverters that convert DC power to the AC power of commercial frequencies

Solar

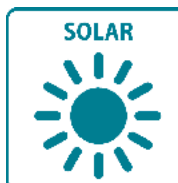

Semiconductor products best suited for power conditioners that convert solar-panel generated DC power into AC power to enable the residential consumption, as well as to facilitate the recovery of the power to the power systems of power companies

Welding Machines



Semiconductor products suitable for switching circuits that generate resistance heat in welding machines to melt and integrate by adding heat or pressure to two or more metallic members

UPS



Semiconductor products ideal for the power conversion circuits of UPS (uninterruptible power supply) that prevent system shutdown during power outages and instantaneous power failures

Switching Power Supplies

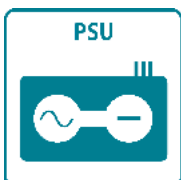

Semiconductor products best suited for general-purpose switching power supplies used in a wide variety of applications such as equipment for general consumers and OA and communication devices

PC / Servers

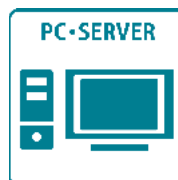

Semiconductor products suitable for the power supplies of increasingly high-performance desktop PCs and servers, as well as of increasingly compact and lightweight notebook PCs

Flat-screen TVs



Semiconductor products ideal for the power supplies of TV sets that require low power consumption and large screens that are increasingly thinner and more lightweight

Automobiles



IGBT modules, power ICs, MOSFETs and pressure sensors as semiconductor products for automobiles developed with the theme "Car Electronics Solutions - Contributing to the Environment, Safety and Comfort"

	Page
1. Power Devices (IGBT)	
Features of IGBT Module X Series.....	6
Features of IGBT Module V Series.....	6
Products Map	8
IGBT Module Small PIM < X series / V series >	11
IGBT Module PIM < X series / V series >	13
IGBT Module 6-Pack < X series / V series >	18
IGBT Module 6-Pack < V series / U series >	20
IGBT Module 2-Pack < X series / V series >	22
IGBT Module 1-Pack < V series / U series >	34
IGBT Module Chopper < V series / U series >	36
IGBT Module High Speed.....	39
IGBT Module 3-level < V series >.....	40
IGBT Module Small IPM < X series >	42
IGBT Module IPM < V series >	43
Discrete IGBT	46
IGBT Module for Electric Vehicle and Hybrid Electric Vehicle..	49
2. SiC Devices	
IGBT Hybrid Modules with SiC-SBD V series	50
SiC Schottky-Barrier Diodes (SBD).....	55
3. Integrated Circuits	
Features of Power Supply control ICs	57
AC/DC Power Supply control ICs	59
High and Low side driver ICs.....	68
DC/DC Power Supply control ICs.....	69
4. Power MOSFETs	
MOSFET Super J-MOS [®] S2 series	70
Features of SuperFAP-E ³ , E ^{3S} series	72
Features of SuperFAP-G series	72
Super J MOS [®] S2 series	74
Super J MOS [®] S1 series.....	77
SuperFAP-E3 series	79
SuperFAP-G series.....	85
Trench Power MOSFET.....	90
Automotive Super J MOS [®] S1 series.....	91
Automotive Super J MOS [®] S2 series	92
Automotive MOSFET (Trench Power MOS, SuperFAP-E ^{3S}).....	93
Automotive SuperFAP-E ^{3S} Low Qg series	94
Automotive Trench Power MOSFET.....	94
Automotive IPS series (Intelligent Power Switches).....	95

	Page
5. Rectifier Diodes	
Features of SBD, LLD.....	96
Schottky-Barrier Diodes (SBD)	98
Ultra Low IR Schottky-Barrier Diodes.....	100
Low IR Schottky-Barrier Diodes	101
Super LLD 2 (Critical mode PFC).....	104
Super LLD 3 (Continuous mode PFC).....	105
Low-Loss Fast Recovery Diodes (LLD).....	106
Low-Loss Fast Soft Recovery Diodes (LLD)	107
Schottky-Barrier Diodes (SBD)	108
Low-Loss Fast Recovery Diodes (LLD).....	108
Ultra Fast Recovery Diodes	109
Soft Recovery Fast Recovery Diodes	110
6. Pressure Sensors	
Pressure Sensors.....	111
Outline	112
Order Quantity	131
Type Number Index	132
Maintenance products	137
Discontinued products	139
Warning	141



IGBT Module



Fuji Electric has been developing IGBT modules designed to be used as switching elements for power converters of variable-speed drives for motors, uninterruptable power supplies, and more. IGBT has superior characteristics combining the high-speed switching performance of a power MOSFET with the high-voltage/high-current handling capabilities of a bipolar transistor.

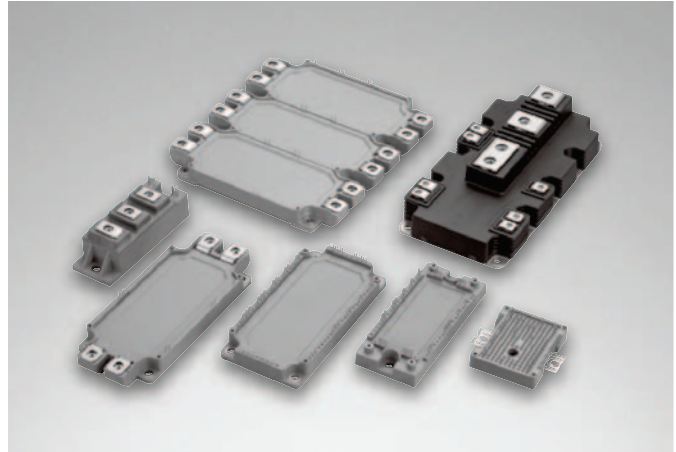

Features of IGBT Module X Series



• Reduces power dissipation to contribute to energy saving

The IGBT and diode devices of Fuji electric's 7th-generation X series that constitute these modules have been made thinner and miniaturized, thereby optimizing the device structure. This has successfully reduced power dissipation in inverter operation compared with conventional products (Fuji Electric's 6th-generation V Series), contributing to energy saving and power cost reduction of the equipment on which the module is installed.

• Achieves equipment size reduction

A newly developed insulating substrate has been applied in order to improve the module's heat dissipation. Combined with the feature described above (reduced power dissipation) to suppress heat generation, an approximately 36%*1 reduction has been

achieved in comparison to the conventional module. In addition, the maximum temperature guaranteed in continuous operation has been increased from the conventional 150°C to 175°C, which allows the output current to be increased by up to 35%*2 while maintaining the size of the equipment on which the module is installed. This contributes to reducing the size and total cost of the equipment.

*1: Mounting area ratio with 1200 V 75A PIM models

*2: Value estimated from simulation results

• Contributes to improving equipment reliability

Newly developed structures and materials of the module have realized to increase its stability and durability in high-temperature operation. This contributes to improving the stability and reliability of the equipment on which the module is installed.

Features of IGBT Module V Series

• A compact design allows for greater power output

- High performance 6th-generation V series IGBT/FWD chipset
- $T_{vj(max.)}=175^{\circ}C$, $T_{vj(op)}=150^{\circ}C$

• Environmentally friendly modules

- Easy assemblage, solder free options
- RoHS compliant (Some parts are Non RoHS.)

• Turn-on switching characteristics

- Improved noise-loss trade-off
- Reduced turn-on dv/dt, excellent turn-on di/dt

• Turn-off switching characteristic

- Soft switching behavior, turn-off oscillation free



Product lineup

Number of IGBT Switches	Products Category	Page	Internal Configuration				Max V_{CE}					Rated Current						
			IGBT Module				600V	650V	1200V	1700V	3300V	≤50A	>50A ≤150A	>150A ≤300A	>300A ≤600A	>600A ≤1200A	>1200A	
			Standard Module	Power Integrated Module	Intelligent Power Module	Discrete IGBT												
7	Small-PIM	11,12		✓				✓	✓	✓			✓					
	PIM EconoPIM™	13,15 14,16		✓				✓	✓				✓	✓				
6	6-pack	18						✓		✓			✓	✓	✓			
		20	✓							✓			✓					
		21								✓	✓			✓	✓			
2	Standard 2-pack	22						✓	✓					✓	✓	✓		
		23,26	✓							✓				✓	✓	✓	✓	
		25,28								✓				✓	✓	✓	✓	
1	Standard 1-pack	34	✓						✓	✓				✓	✓	✓		
	Chopper	36	✓					✓					✓	✓	✓	✓		
1,2	High Speed Module	39	✓						✓	✓				✓	✓	✓		
	High Power Module	30,31,35	✓						✓	✓	✓				✓	✓	✓	✓
	PrimePACK™	32,33,37,38	✓						✓	✓					✓	✓	✓	✓
4,12	T/I-type NPC 3-level	40,41	Reverse-Blocking IGBTs are integrated.				✓		✓	✓			✓	✓	✓	✓	✓	
6,7	IPM	42,43,44						✓	✓	✓			✓	✓	✓	✓		
1	Discrete IGBT	45				✓		✓	✓				✓	✓				
1	Discrete RB-IGBT	48				✓		✓					✓					
2	IPM for EV/HEV	49			✓					✓						✓		
6	6-pack for EV/HEV	49	✓					✓(750V)								✓	✓	

Note: PrimePACK™ is registered trademark of Infineon Technologies AG, Germany.
EconoPIM™ is registered trademark of Infineon Technologies AG, Germany.

Part numbers

6MBI100XBA120-50 (example)

6	MB	I	100	X	BA	120	50
Number of IGBT Switches	IGBT Module	Internal Configuration	Rated Current	IGBT Device Technology	Package Type	Max. V_{CE}	RoHS Compliant
		I: Standard Modules	x 1 (A)	X: X series (7th Generation)	See the Products map	060: 600V	50 to 99 RoHS Compliant
		R: Power Integrated Modules	ex) 100: 100A	V: V series (6th Generation)		065: 650V	
		P: Intelligent Power Modules		U: U series (5th Generation)		120: 1200V	
						170: 1700V	
						330: 3300V	

Letter symbols

Letter symbols

V_{CES} : Collector-to-emitter rated voltage (Gate-to-emitter short-circuited)
 V_{GES} : Gate-to-emitter rated voltage (Collector-to-emitter short-circuited)
 I_C : Rated collector current
 P_C : Maximum power dissipation

$V_{CE(sat)}$: Collector-to-emitter saturation voltage
 t_{on} : Turn-on time
 t_{off} : Turn-off time
 t_f : Fall time
 $t_{d(on)}$: Turn-on time
 $t_{d(off)}$: Turn-off time



Products Map

PIM (Power Integrated Modules)

7MBR	Ic	IGBT series & Package type				Size	Page	EconoPIM™
		V series		X series				
		Solder pins	Press fit pins	Solder pins	Press fit pins			
		VKC	VKA	XKC	XKA	33.8×62.8mm	11,12	
		VKD	VKB	XKD	XKB	56.7×62.8mm	11,12	
		VA, VM, VP	VW, VY	XM□, XP□	XW□, XY□	45×107.5mm	13,14,15,16	
		VB, VN, VR	VX, VZ	XN□, XR□	XX□, XZ□	62×122mm	13,14,15,16	

Note: EconoPIM™ is registered trademark of Infineon Technologies AG, Germany.

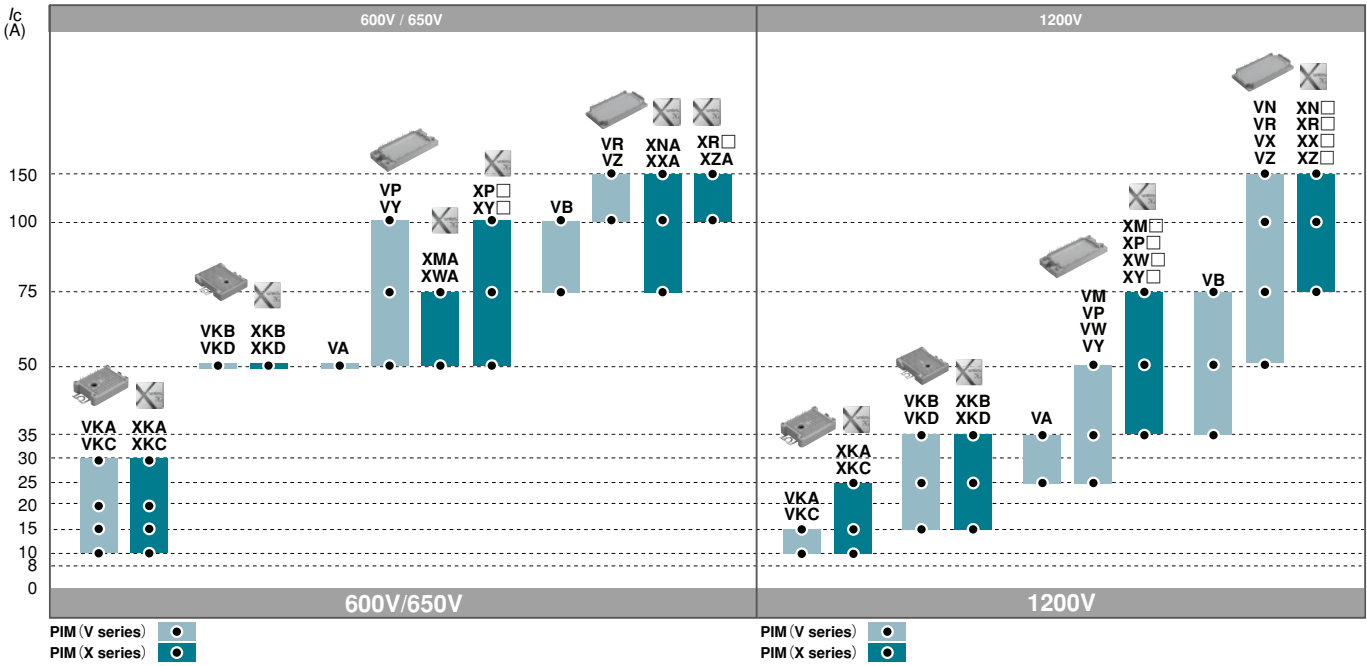

6-Pack

6MBI	Ic	IGBT series & Package type				Size	Page	EconoPACK™
		V/U series		X series				
		Solder pins	Press fit pins	Solder pins	Press fit pins			
		VA,	VW	XAE		45×107.5mm	18	
		VB, U4B	VX	XB□	XX□	62×122mm	18,20	
		V				150×162mm	21	EconoPACK™+

Note: EconoPACK™ and EconoPACK™+ are registered trademark of Infineon Technologies AG, Germany.

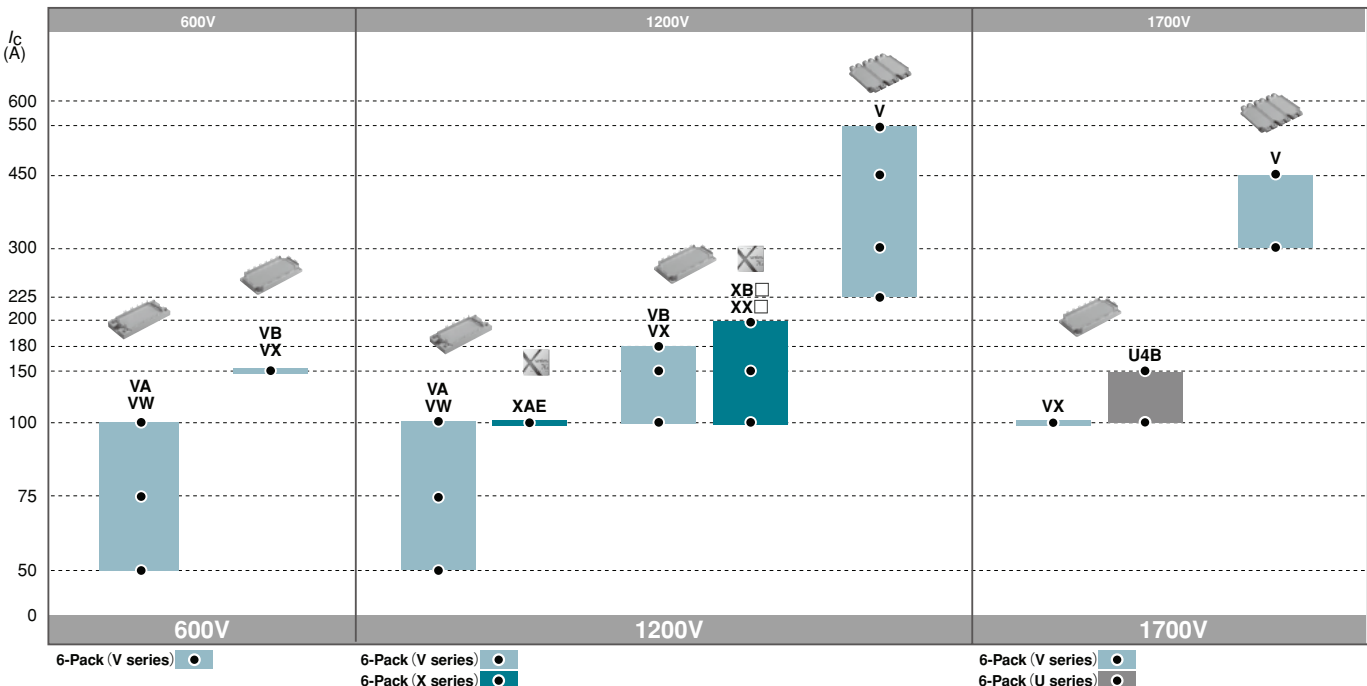



2-Pack

2MBI	Ic	IGBT series & Package type		Size	Page	
		V series	X series			
	VA	XAA	34×94mm	22,23,25	Standard Pack	
	VB	XBE	45×92mm	22,23		
	VD	XDE	62×108mm	22,23		
	VE	XEE	80×110mm	22,23,25		
	VH	XHA	62×108mm	23,25		
	VJ, VN, VX	XN□	62×150mm	26,28		
	-	XUF, XVF	100×140mm	30	HPnC	
	VG, VT	-	140×130mm	31	High Power Module	
	VXA	XXA, XXE	89×172mm	32,33	PrimePACK™	
	VXB	XXB, XXF	89×250mm	32,33		

PrimePACK™ is registered trademark of Infineon Technologies AG, Germany

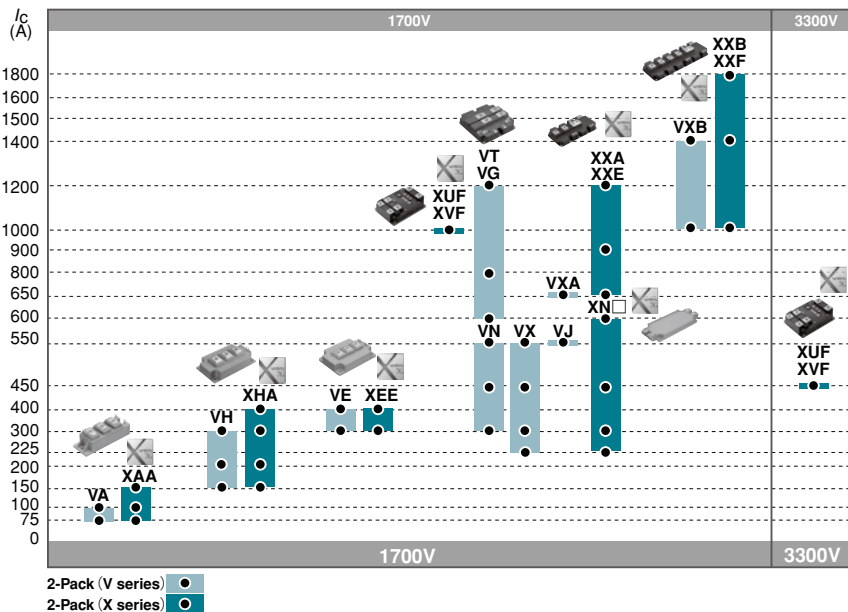
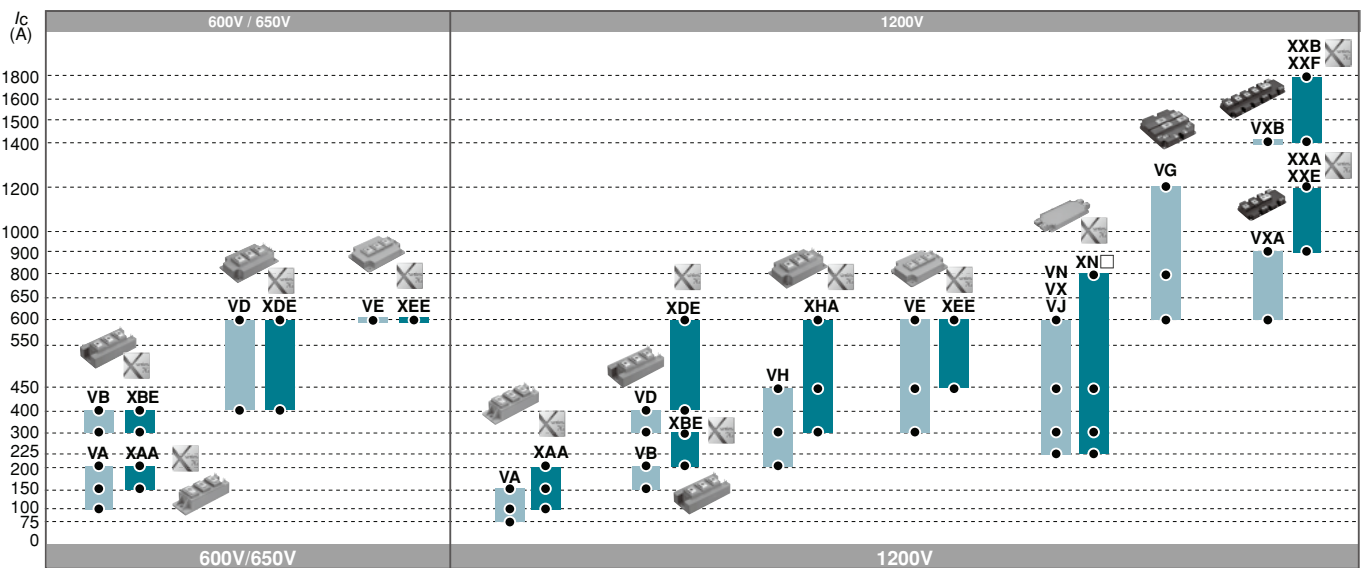



Power Devices (IGBT)

1-Pack

1MBI	Ic	IGBT series & Package type		Page	
		V/U series	Size		
		V	62×108mm	34	Standard Pack
		VC, VR, UG	140×130mm	35	High Powe Module
		VD, VS, UE	140×190mm	35	

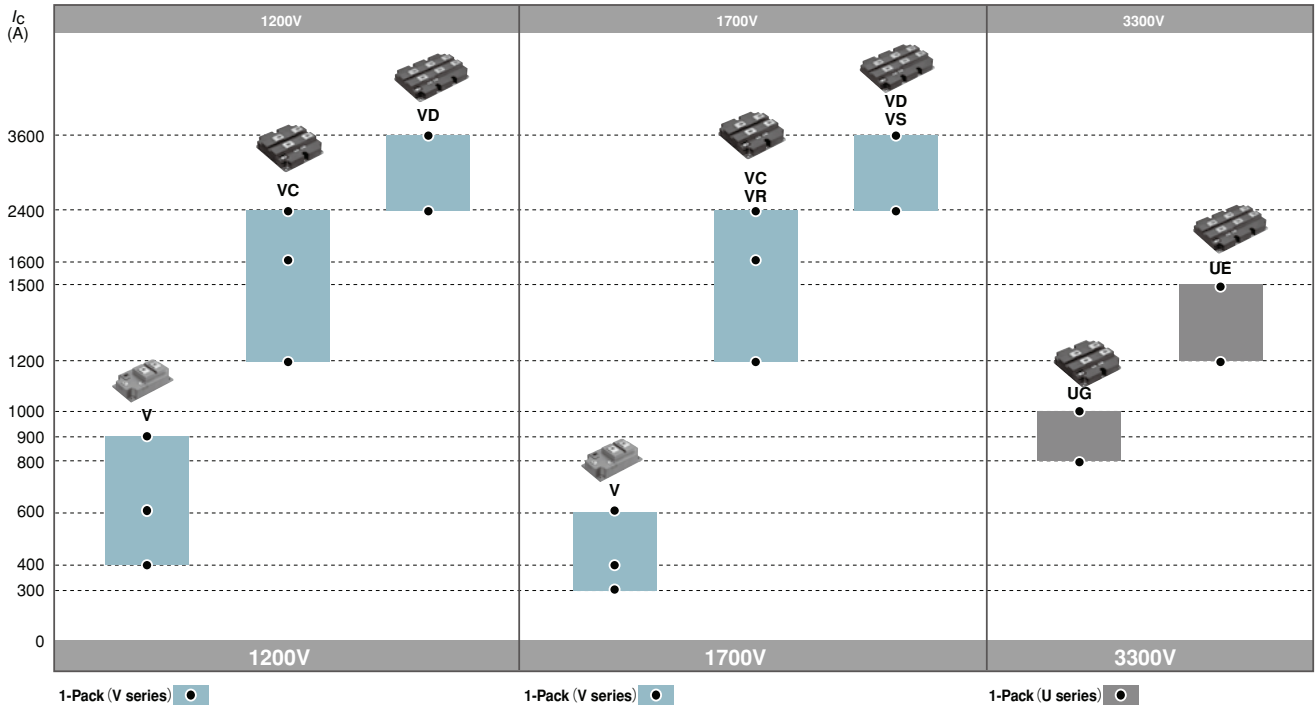

IPM (Intelligent Power Modules)

6/7MBP	Ic	IGBT series & Package type	Size	V series		X series	Page
				7 in 1	6 in 1	6 in 1	
		XSD, XSF	26×43mm	-	-	✓	42
		VAA	49.5×70mm	-	✓	-	43
		VBA	50.2×87mm	-	✓	-	43
		VFN	55×90mm	✓	✓	-	43
		VDA, VDN	84×128.5mm	✓	✓	-	44
		VEA	110×142mm	✓	✓	-	44

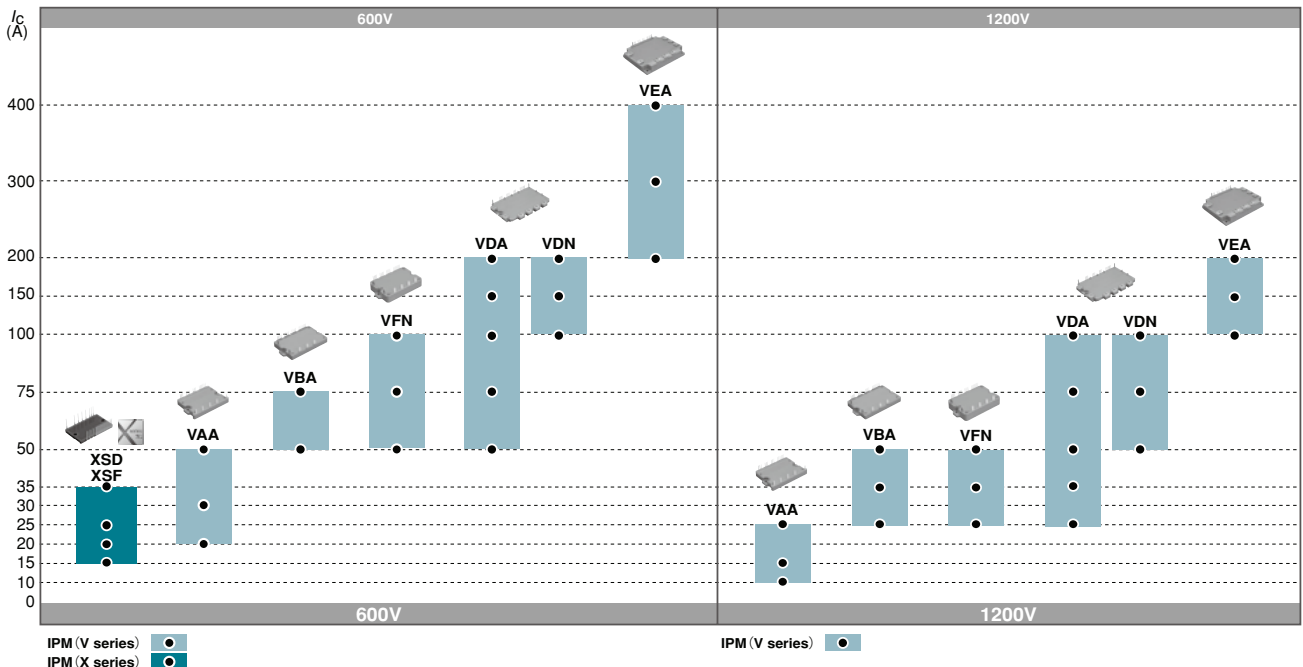



IGBT Module PIM < X series / V series >

Small PIM/Built-in converter and brake 650V, 600V class

Press fit pins	650V	600V	
			X series
 V:M726, X:M730 	10A	7MBR10XKA065-50	7MBR10VKA060-50
	15A	7MBR15XKA065-50	7MBR15VKA060-50
	20A	7MBR20XKA065-50	7MBR20VKA060-50
	30A	7MBR30XKA065-50	7MBR30VKA060-50
 V:M727, X:M731 	50A	7MBR50XKB065-50	7MBR50VKB060-50
 V:M728, X:M732 	10A	7MBR10XKC065-50	7MBR10VKC060-50
	15A	7MBR15XKC065-50	7MBR15VKC060-50
	20A	7MBR20XKC065-50	7MBR20VKC060-50
	30A	7MBR30XKC065-50	7MBR30VKC060-50
 V:M729, X:M733 	50A	7MBR50XKD065-50	7MBR50VKD060-50

Dimension [mm]

Device type	Inverter [IGBT]				Brake [IGBT+FWD]			Converter [Diode]				Package	Net mass
	V _{CES}	I _C	P _C	V _{CE(sat)}	V _{CES}	I _C	V _{RRM}	V _{RRM}	I _O	V _{FM}	I _{FSM}		
	Volts	Cont. Amps.	Watts	typ. Volts	Volts	Cont. Amps.	Volts	Volts	Cont. Amps.	typ. Volts	Cont. Amps.		Grams
● 7MBR10XKA065-50	650	10	90	1.30	650	10	650	800	10	0.90	340	M730	25
● 7MBR15XKA065-50	650	15	110	1.30	650	15	650	800	15	0.95	340	M730	25
● 7MBR20XKA065-50	650	20	135	1.30	650	20	650	800	20	1.00	340	M730	25
● 7MBR30XKA065-50	650	30	180	1.30	650	30	650	800	30	1.05	340	M730	25
● 7MBR50XKB065-50	650	50	270	1.30	650	50	650	800	50	1.10	470	M731	45
● 7MBR10XKC065-50	650	10	90	1.30	650	10	650	800	10	0.90	340	M732	25
● 7MBR15XKC065-50	650	15	110	1.30	650	15	650	800	15	0.95	340	M732	25
● 7MBR20XKC065-50	650	20	135	1.30	650	20	650	800	20	1.00	340	M732	25
● 7MBR30XKC065-50	650	30	180	1.30	650	30	650	800	30	1.05	340	M732	25
● 7MBR50XKD065-50	650	50	270	1.30	650	50	650	800	50	1.10	470	M733	45
7MBR10VKA060-50	600	10	70	1.70	600	10	600	800	10	0.95	360	M726	25
7MBR15VKA060-50	600	15	85	1.75	600	15	600	800	15	1.00	360	M726	25
7MBR20VKA060-50	600	20	100	1.70	600	20	600	800	20	1.05	360	M726	25
7MBR30VKA060-50	600	30	125	1.70	600	30	600	800	30	1.15	360	M726	25
7MBR50VKB060-50	600	50	180	1.60	600	50	600	800	50	1.00	580	M727	45
7MBR10VKC060-50	600	10	70	1.70	600	10	600	800	10	0.95	360	M728	25
7MBR15VKC060-50	600	15	85	1.75	600	15	600	800	15	1.00	360	M728	25
7MBR20VKC060-50	600	20	100	1.70	600	20	600	800	20	1.05	360	M728	25
7MBR30VKC060-50	600	30	125	1.70	600	30	600	800	30	1.15	360	M728	25
7MBR50VKD060-50	600	50	180	1.60	600	50	600	800	50	1.00	580	M729	45

● : New products

V_{CE(sat)}, V_{FM}: at T_{vj}=25°C, Chip

IGBT Module PIM < X series / V series >

Small PIM/Built-in converter and brake 1200V class

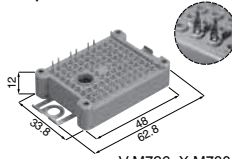
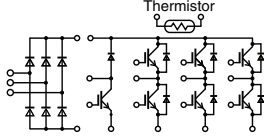
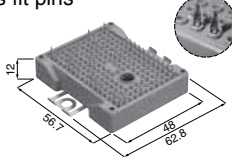
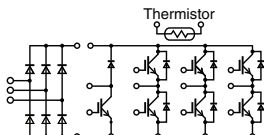
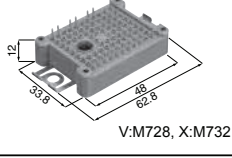
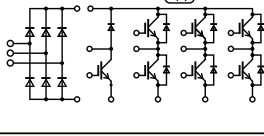
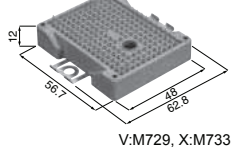
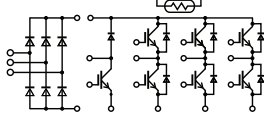
Press fit pins	Thermistor	I_c	1200V	
			X series	V series
 V:M726, X:M730		10A	7MBR10XKA120-50	7MBR10VKA120-50
		15A	7MBR15XKA120-50	7MBR15VKA120-50
		25A	7MBR25XKA120-50	
 V:M727, X:M731		15A	7MBR15XKB120-50	7MBR15VKB120-50
		25A	7MBR25XKB120-50	7MBR25VKB120-50
		35A	7MBR35XKB120-50	7MBR35VKB120-50
 V:M728, X:M732		10A	7MBR10XKC120-50	7MBR10VKC120-50
		15A	7MBR15XKC120-50	7MBR15VKC120-50
		25A	7MBR25XKC120-50	
 V:M729, X:M733		15A	7MBR15XKD120-50	7MBR15VKD120-50
		25A	7MBR25XKD120-50	7MBR25VKD120-50
		35A	7MBR35XKD120-50	7MBR35VKD120-50

Dimension [mm]

Device type	Inverter [IGBT]				Brake [IGBT+FWD]				Converter [Diode]				Package	Net mass Grams
	V_{CES}	I_c	P_C	$V_{CE(sat)}$	V_{CES}	I_c	V_{RRM}	V_{RRM}	I_o	V_{FM}	I_{FSM}			
	Volts	Cont. Amps.	Watts	typ. Volts	Volts	Cont. Amps.	Volts	Volts	Cont. Amps.	typ. Volts	Amps.			
● 7MBR10XKA120-50	1200	10	105	1.50	1200	10	1200	1600	10	0.95	300	M730	25	
● 7MBR15XKA120-50	1200	15	135	1.50	1200	15	1200	1600	15	1.00	300	M730	25	
● 7MBR25XKA120-50	1200	25	155	1.70	1200	25	1200	1600	25	1.05	300	M730	25	
● 7MBR15XKB120-50	1200	15	135	1.50	1200	15	1200	1600	15	0.95	385	M731	45	
● 7MBR25XKB120-50	1200	25	195	1.50	1200	25	1200	1600	25	1.00	385	M731	45	
● 7MBR35XKB120-50	1200	35	255	1.50	1200	35	1200	1600	35	1.05	385	M731	45	
● 7MBR10XKC120-50	1200	10	105	1.50	1200	10	1200	1600	10	0.95	300	M732	25	
● 7MBR15XKC120-50	1200	15	135	1.50	1200	15	1200	1600	15	1.00	300	M732	25	
● 7MBR25XKC120-50	1200	25	155	1.70	1200	25	1200	1600	25	1.05	300	M732	25	
● 7MBR15XKD120-50	1200	15	135	1.50	1200	15	1200	1600	15	0.95	385	M733	45	
● 7MBR25XKD120-50	1200	25	195	1.50	1200	25	1200	1600	25	1.00	385	M733	45	
● 7MBR35XKD120-50	1200	35	255	1.50	1200	35	1200	1600	35	1.05	385	M733	45	
7MBR10VKA120-50	1200	10	110	1.85	1200	10	1200	1600	10	0.95	245	M726	25	
7MBR15VKA120-50	1200	15	135	1.90	1200	15	1200	1600	15	1.00	245	M726	25	
7MBR15VKB120-50	1200	15	135	1.90	1200	15	1200	1600	15	1.00	245	M727	45	
7MBR25VKB120-50	1200	25	180	1.85	1200	25	1200	1600	25	1.00	370	M727	45	
7MBR35VKB120-50	1200	35	215	1.85	1200	35	1200	1600	35	1.05	370	M727	45	
7MBR10VKC120-50	1200	10	110	1.85	1200	10	1200	1600	10	0.95	245	M728	25	
7MBR15VKC120-50	1200	15	135	1.90	1200	15	1200	1600	15	1.00	245	M728	25	
7MBR15VKD120-50	1200	15	135	1.90	1200	15	1200	1600	15	1.00	245	M729	45	
7MBR25VKD120-50	1200	25	180	1.85	1200	25	1200	1600	25	1.00	370	M729	45	
7MBR35VKD120-50	1200	35	215	1.85	1200	35	1200	1600	35	1.05	370	M729	45	

● : New products

$V_{CE(sat)}$, V_{FM} : at $T_v=25^\circ\text{C}$, Chip



IGBT Module PIM < X series / V series >

■ PIM/Built-in converter and brake EconoPIM™ 650V, 600V class

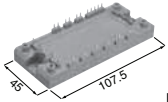
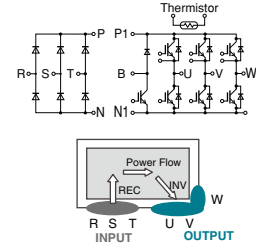
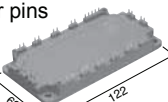
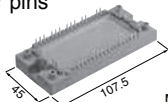
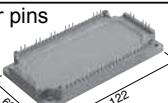
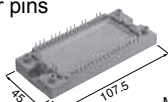
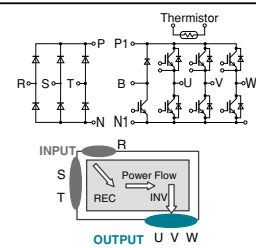
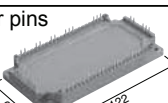
Solder pins	Thermistor	Ic	650V	600V
			X series	V series
 M711		50A		7MBR50VA060-50
 M712		75A		7MBR75VB060-50
		100A		7MBR100VB060-50
 M719		50A	7MBR50XMA065-50	
		75A	7MBR75XMA065-50	
 M720		75A	7MBR75XNA065-50	
	100A	7MBR100XNA065-50		
	150A	7MBR150XNA065-50		
 M719		50A	7MBR50XPA065-50	7MBR50VP060-50
		75A	7MBR75XPA065-50	7MBR75VP060-50
		100A	7MBR100XPE065-50	7MBR100VP060-50
 M720		100A	7MBR100XRA065-50	7MBR100VR060-50
		150A	7MBR150XRA065-50	7MBR150VR060-50
			7MBR150XRE065-50	

Dimension [mm]

Device type	Inverter [IGBT]				Brake [IGBT+FWD]			Converter [Diode]				Package	Net mass Grams
	V _{CES}	I _c	P _C	V _{CE(sat)}	V _{CES}	I _c	V _{RRM}	V _{RRM}	I _O	V _{FM}	I _{FSM}		
	Volts	Amps.	Watts	Volts	Volts	Amps.	Volts	Volts	Amps.	Volts	Amps.		
● 7MBR50XMA065-50	650	50	210	1.3	650	30	650	800	50	1.05	505	M719	200
● 7MBR75XMA065-50	650	75	270	1.3	650	50	650	800	75	1.15	505	M719	200
● 7MBR75XNA065-50	650	75	270	1.3	650	50	650	800	75	1.15	505	M720	310
● 7MBR100XNA065-50	650	100	330	1.3	650	50	650	800	100	1.1	745	M720	310
● 7MBR150XNA065-50	650	150	450	1.3	650	75	650	800	150	1.1	1260	M720	310
● 7MBR50XPA065-50	650	50	210	1.3	650	30	650	800	50	1.05	545	M719	200
● 7MBR75XPA065-50	650	75	270	1.3	650	50	650	800	75	1.15	505	M719	200
● 7MBR100XPE065-50	650	100	480	1.3	650	50	650	800	100	1.1	745	M719	200
● 7MBR100XRA065-50	650	100	330	1.3	650	50	650	800	100	1.1	745	M720	310
● 7MBR150XRA065-50	650	150	450	1.3	650	75	650	800	150	1.1	1260	M720	310
● 7MBR150XRE065-50	650	150	700	1.3	650	75	650	800	150	1.1	1260	M720	310
7MBR50VA060-50	600	50	200	1.6	600	50	600	800	50	1.3	210	M711	180
7MBR75VB060-50	600	75	300	1.6	600	50	600	800	75	1.25	500	M712	300
7MBR100VB060-50	600	100	335	1.6	600	50	600	800	100	1.25	700	M712	300
7MBR50VP060-50	600	50	200	1.6	600	50	600	800	50	1.3	210	M719	200
7MBR75VP060-50	600	75	300	1.6	600	50	600	800	75	1.25	500	M719	200
7MBR100VP060-50	600	100	430	1.85	600	50	600	800	100	1.25	700	M719	200
7MBR100VR060-50	600	100	335	1.6	600	50	600	800	100	1.25	700	M720	310
7MBR150VR060-50	600	150	485	1.6	600	75	600	800	150	1.25	960	M720	310

Note: EconoPIM™ is registered trademark of Infineon Technologies AG, Germany.

V_{CE(sat)}, V_{FM}: at T_{vj}=25°C, Chip

● : New products

IGBT Module PIM < X series / V series >

PIM/Built-in converter and brake EconoPIM™ 1200V class

Solder pins	Thermistor	Ic	1200V	
			X series	V series
 M711		25A		7MBR25VA120-50
		35A		7MBR35VA120-50
 M712		35A		7MBR35VB120-50
		50A		7MBR50VB120-50
		75A		7MBR75VB120-50
 M719		25A		7MBR25VM120-50
		35A	7MBR35XMA120-50	7MBR35VM120-50
 M720		50A	7MBR50XMA120-50	7MBR50VM120-50
		75A	7MBR75XME120-50	
		50A		7MBR50VN120-50
		75A	7MBR75XNA120-50	7MBR75VN120-50
 M719		100A	7MBR100XNA120-50	7MBR100VN120-50
		150A	7MBR150XNE120-50	7MBR150VN120-50
		25A		7MBR25VP120-50
 M719		35A	7MBR35XPA120-50	7MBR35VP120-50
		50A	7MBR50XPA120-50	7MBR50VP120-50
 M720		75A	7MBR75XPE120-50	
		50A		7MBR50VR120-50
		75A	7MBR75XRA120-50	7MBR75VR120-50
 M720		100A	7MBR100XRE120-50	7MBR100VR120-50
		150A	7MBR150XRE120-50	7MBR150VR120-50

Dimension [mm]

Device type	Inverter [IGBT]				Brake [IGBT+FWD]			Converter [Diode]				Package	Net mass
	V _{CEs}	I _c Cont.	P _C	V _{CE(sat)} typ.	V _{CEs}	I _c Cont.	V _{RRM}	V _{RRM}	I _o Cont.	V _{FM} typ.	I _{FSM}		
	Volts	Amps.	Watts	Volts	Volts	Amps.	Volts	Volts	Amps.	Volts	Amps.		Grams
● 7MBR35XMA120-50	1200	35	200	1.5	1200	25	1200	1600	35	1.05	385	M719	200
● 7MBR50XMA120-50	1200	50	250	1.5	1200	35	1200	1600	50	1.05	520	M719	200
● 7MBR75XME120-50	1200	75	455	1.55	1200	35	1200	1600	75	1.15	520	M719	200
● 7MBR75XNA120-50	1200	75	335	1.5	1200	50	1200	1600	75	1.15	520	M720	310
● 7MBR100XNA120-50	1200	100	445	1.45	1200	75	1200	1600	100	1.05	775	M720	310
● 7MBR150XNE120-50	1200	150	880	1.5	1200	75	1200	1600	150	1.05	1400	M720	310
● 7MBR35XPA120-50	1200	35	200	1.5	1200	25	1200	1600	35	1.05	385	M719	200
● 7MBR50XPA120-50	1200	50	250	1.5	1200	35	1200	1600	50	1.05	520	M719	200
● 7MBR50XPE120-50	1200	50	340	1.5	1200	35	1200	1600	50	1.05	520	M719	200
● 7MBR75XPE120-50	1200	75	455	1.55	1200	35	1200	1600	75	1.15	520	M719	200
● 7MBR75XRA120-50	1200	75	335	1.5	1200	50	1200	1600	75	1.15	520	M720	310
● 7MBR75XRE120-50	1200	75	525	1.5	1200	50	1200	1600	75	1.0	775	M720	310
● 7MBR100XRA120-50	1200	100	445	1.45	1200	75	1200	1600	100	1.05	775	M720	310
● 7MBR100XRE120-50	1200	100	685	1.45	1200	75	1200	1600	100	1.05	775	M720	310
● 7MBR150XRE120-50	1200	150	880	1.5	1200	75	1200	1600	150	1.05	1400	M720	310
7MBR25VA120-50	1200	25	170	1.85	1200	25	1200	1600	25	1.42	155	M711	180
7MBR35VA120-50	1200	35	210	1.85	1200	25	1200	1600	35	1.35	260	M711	180
7MBR35VB120-50	1200	35	210	1.85	1200	25	1200	1600	35	1.35	260	M712	300
7MBR50VB120-50	1200	50	280	1.85	1200	35	1200	1600	50	1.35	360	M712	300
7MBR75VB120-50	1200	75	385	1.85	1200	50	1200	1600	75	1.4	520	M712	300
7MBR25VM120-50	1200	25	170	1.85	1200	25	1200	1600	25	1.4	155	M719	200
7MBR35VM120-50	1200	35	210	1.85	1200	25	1200	1600	35	1.35	260	M719	200
7MBR50VM120-50	1200	50	280	1.85	1200	35	1200	1600	50	1.35	360	M719	200
7MBR50VN120-50	1200	50	280	1.85	1200	35	1200	1600	50	1.35	360	M720	310
7MBR75VN120-50	1200	75	385	1.85	1200	50	1200	1600	75	1.4	520	M720	310
7MBR100VN120-50	1200	100	520	1.75	1200	75	1200	1600	100	1.5	520	M720	310
7MBR150VN120-50	1200	150	885	1.85	1200	100	1200	1600	150	1.4	780	M720	310
7MBR25VP120-50	1200	25	170	1.85	1200	25	1200	1600	25	1.4	155	M719	200
7MBR35VP120-50	1200	35	210	1.85	1200	25	1200	1600	35	1.35	260	M719	200
7MBR50VP120-50	1200	50	280	1.85	1200	35	1200	1600	50	1.35	360	M719	200
7MBR50VR120-50	1200	50	280	1.85	1200	35	1200	1600	50	1.35	360	M720	310
7MBR75VR120-50	1200	75	385	1.85	1200	50	1200	1600	75	1.4	520	M720	310
7MBR100VR120-50	1200	100	520	1.75	1200	75	1200	1600	100	1.5	520	M720	310
7MBR150VR120-50	1200	150	885	1.85	1200	100	1200	1600	150	1.4	780	M720	310

Note: EconoPIM™ is registered trademark of Infineon Technologies AG, Germany.

● : New products

V_{CE(sat)}, V_{FM}: at T_{vj}=25°C, Chip



IGBT Module PIM < X series / V series >

■ PIM/Built-in converter and brake EconoPIM™ 650V, 600V class

Press fit pins	Diagram	Ic	650V	600V
			X series	V series
 M721		50A	7MBR50XWA065-50	
		75A	7MBR75XWA065-50	
 M722		75A	7MBR75XXA065-50	
		100A	7MBR100XXA065-50	
		150A	7MBR150XXA065-50	
 M721		50A	7MBR50XYA065-50	7MBR50VY060-50 7MBR50VY060-80
		75A	7MBR75XYA065-50	7MBR75VY060-50 7MBR75VY060-80
 M722		100A	7MBR100XE065-50	7MBR100VY060-50 7MBR100VY060-80
		100A	7MBR100XZA065-50	7MBR100VZ060-50 7MBR100VZ060-80
		150A	7MBR150XZA065-50	7MBR150VZ060-50 7MBR150VZ060-80

Dimension [mm]

Device type	Inverter [IGBT]				Brake [IGBT+FWD]			Converter [Diode]				Package	Net mass Grams
	V _{CEs}	I _c	P _c	V _{CE(sat)}	V _{CEs}	I _c	V _{RRM}	V _{RRM}	I _o	V _{FM}	I _{FSM}		
	Volts	Cont. Amps.	Watts	typ. Volts	Volts	Cont. Amps.	Volts	Volts	Cont. Amps.	typ. Volts	Amps.		
● 7MBR50XWA065-50	650	50	210	1.3	650	30	650	800	50	1.05	505	M721	200
● 7MBR75XWA065-50	650	75	270	1.3	650	50	650	800	75	1.15	505	M721	200
● 7MBR75XXA065-50	650	75	270	1.3	650	50	650	800	75	1.15	505	M722	310
● 7MBR100XXA065-50	650	100	330	1.3	650	50	650	800	100	1.1	745	M722	310
● 7MBR150XXA065-50	650	150	450	1.3	650	75	650	800	150	1.1	1260	M722	310
● 7MBR50XYA065-50	650	50	210	1.3	650	30	650	800	50	1.05	545	M721	200
● 7MBR75XYA065-50	650	75	270	1.3	650	50	650	800	75	1.15	505	M721	200
● 7MBR100XE065-50	650	100	480	1.3	650	50	650	800	100	1.1	745	M721	200
● 7MBR100XZA065-50	650	100	330	1.3	650	50	650	800	100	1.1	745	M722	310
● 7MBR150XZA065-50	650	150	450	1.3	650	75	650	800	150	1.1	1260	M722	310
7MBR50VY060-50	600	50	215	1.6	600	50	600	800	50	1.3	210	M721	200
7MBR50VY060-80	600	50	215	1.6	600	50	600	800	50	1.3	210	M721	200
7MBR75VY060-50	600	75	300	1.6	600	50	600	800	75	1.25	500	M721	200
7MBR75VY060-80	600	75	300	1.6	600	50	600	800	75	1.25	500	M721	200
7MBR100VY060-50	600	100	430	1.85	600	50	600	800	100	1.25	700	M721	200
7MBR100VY060-80	600	100	430	1.85	600	50	600	800	100	1.25	700	M721	200
7MBR100VZ060-50	600	100	335	1.6	600	50	600	800	100	1.25	700	M722	310
7MBR100VZ060-80	600	100	335	1.6	600	50	600	800	100	1.25	700	M722	310
7MBR150VZ060-50	600	150	485	1.6	600	75	600	800	150	1.25	960	M722	310
7MBR150VZ060-80	600	150	485	1.6	600	75	600	800	150	1.25	960	M722	310

Note1: EconoPIM™ is registered trademark of Infineon Technologies AG, Germany.

Note2: "-80" : Pre-Applied Thermal-Interface-Material

● : New products

V_{CE(sat)}, V_{FM}: at T_{vj}=25°C, Chip

IGBT

IGBT Module PIM < X series / V series >

PIM/Built-in converter and brake EconoPIM™ 1200V class

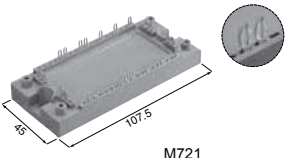
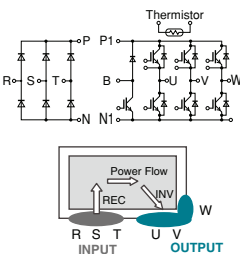
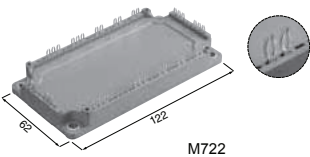
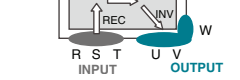
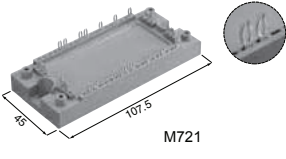
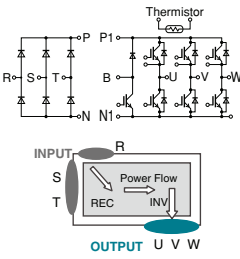
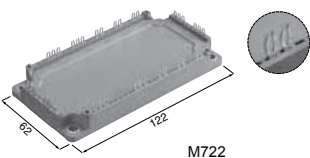
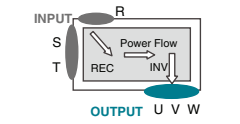
Press fit pins	Diagram	Ic	1200V	
			X series	V series
 M721 45 x 107.5 mm		25A		7MBR25VW120-50
		35A	7MBR35XWA120-50	7MBR35VW120-50
		50A	7MBR50XWA120-50	7MBR50VW120-50
		75A	7MBR75XWE120-50	7MBR50VW120-80
		50A		7MBR50VX120-50
 M722 62 x 122 mm		75A	7MBR75XXA120-50	7MBR75VX120-50
		100A	7MBR100XXA120-50	7MBR100VX120-50
		150A	7MBR150XXE120-50	7MBR150VX120-50
				7MBR150VX120-80
				7MBR150VX120-80
 M721 45 x 107.5 mm		25A		7MBR25VY120-50
		35A	7MBR35XYA120-50	7MBR35VY120-50
		50A	7MBR50XYA120-50	7MBR50VY120-50
		75A	7MBR75XYE120-50	7MBR50VY120-80
		50A		7MBR50VZ120-50
 M722 62 x 122 mm		75A	7MBR75XZA120-50	7MBR75VZ120-50
		100A	7MBR100XZA120-50	7MBR100VZ120-50
		150A	7MBR150XZE120-50	7MBR150VZ120-50
				7MBR150VZ120-80
				7MBR150VZ120-80

Dimension [mm]

Device type	Inverter [IGBT]				Brake [IGBT+FWD]			Converter [Diode]				Package	Net mass
	V _{CES}	I _c	P _C	V _{CE(sat)}	V _{CES}	I _c	V _{RRM}	V _{RRM}	I _o	V _{FM}	I _{FSM}		
	Volts	Cont. Amps.	Watts	typ. Volts	Volts	Cont. Amps.	Volts	Volts	Cont. Amps.	typ. Volts	Amps.		
● 7MBR35XWA120-50	1200	35	200	1.5	1200	25	1200	1600	35	1.05	385	M721	200
● 7MBR50XWA120-50	1200	50	250	1.5	1200	35	1200	1600	50	1.05	520	M721	200
● 7MBR75XWE120-50	1200	75	455	1.55	1200	35	1200	1600	75	1.15	520	M721	200
● 7MBR75XXA120-50	1200	75	335	1.5	1200	50	1200	1600	75	1.15	520	M722	310
● 7MBR100XXA120-50	1200	100	445	1.45	1200	75	1200	1600	100	1.05	775	M722	310
● 7MBR150XXE120-50	1200	150	880	1.5	1200	75	1200	1600	150	1.05	1400	M722	310
● 7MBR35XYA120-50	1200	35	200	1.5	1200	25	1200	1600	35	1.05	385	M721	200
● 7MBR50XYA120-50	1200	50	250	1.5	1200	35	1200	1600	50	1.05	520	M721	200
● 7MBR75XYE120-50	1200	75	455	1.55	1200	35	1200	1600	75	1.15	520	M721	200
● 7MBR75XZA120-50	1200	75	335	1.5	1200	50	1200	1600	75	1.15	520	M722	310
● 7MBR100XZA120-50	1200	100	445	1.45	1200	75	1200	1600	100	1.05	775	M722	310
● 7MBR150XZE120-50	1200	150	880	1.5	1200	75	1200	1600	150	1.05	1400	M722	310

Note1: EconoPIM™ is registered trademark of Infineon Technologies AG, Germany.

Note2: "-80": Pre-Applied Thermal-Interface-Material

●: New products

V_{CE(sat)}, V_{FM}: at T_{vj}=25°C, Chip



Device type	Inverter [IGBT]				Brake [IGBT+FWD]			Converter [Diode]				Package	Net mass Grams
	V_{CES}	I_C	P_C	$V_{CE(sat)}$	V_{CES}	I_C	V_{RRM}	V_{RRM}	I_C	V_{FM}	I_{FSM}		
	Volts	Cont. Amps.	Watts	typ. Volts	Volts	Cont. Amps.	Volts	Volts	Cont. Amps.	typ. Volts	Amps.		
7MBR25VW120-50	1200	25	170	1.85	1200	25	1200	1600	25	1.4	155	M721	200
7MBR25VW120-80	1200	25	170	1.85	1200	25	1200	1600	25	1.4	155	M721	200
7MBR35VW120-50	1200	35	210	1.85	1200	25	1200	1600	35	1.35	260	M721	200
7MBR35VW120-80	1200	35	210	1.85	1200	25	1200	1600	35	1.35	260	M721	200
7MBR50VW120-50	1200	50	280	1.85	1200	35	1200	1600	50	1.35	360	M721	200
7MBR50VW120-80	1200	50	280	1.85	1200	35	1200	1600	50	1.35	360	M721	200
7MBR50VX120-50	1200	50	280	1.85	1200	35	1200	1600	50	1.35	360	M722	310
7MBR50VX120-80	1200	50	280	1.85	1200	35	1200	1600	50	1.35	360	M722	310
7MBR75VX120-50	1200	75	385	1.85	1200	50	1200	1600	75	1.4	520	M722	310
7MBR75VX120-80	1200	75	385	1.85	1200	50	1200	1600	75	1.4	520	M722	310
7MBR100VX120-50	1200	100	520	1.75	1200	75	1200	1600	100	1.5	520	M722	310
7MBR100VX120-80	1200	100	520	1.75	1200	75	1200	1600	100	1.5	520	M722	310
7MBR150VX120-50	1200	150	885	1.85	1200	100	1200	1600	150	1.4	780	M722	310
7MBR150VX120-80	1200	150	885	1.85	1200	100	1200	1600	150	1.4	780	M722	310
7MBR25VY120-50	1200	25	170	1.85	1200	25	1200	1600	25	1.42	155	M721	200
7MBR25VY120-80	1200	25	170	1.85	1200	25	1200	1600	25	1.42	155	M721	200
7MBR35VY120-50	1200	35	210	1.85	1200	25	1200	1600	35	1.35	260	M721	200
7MBR35VY120-80	1200	35	210	1.85	1200	25	1200	1600	35	1.35	260	M721	200
7MBR50VY120-50	1200	50	280	1.85	1200	35	1200	1600	50	1.35	360	M721	200
7MBR50VY120-80	1200	50	280	1.85	1200	35	1200	1600	50	1.35	360	M721	200
7MBR50VZ120-50	1200	50	280	1.85	1200	35	1200	1600	50	1.35	360	M722	310
7MBR50VZ120-80	1200	50	280	1.85	1200	35	1200	1600	50	1.35	360	M722	310
7MBR75VZ120-50	1200	75	385	1.85	1200	50	1200	1600	75	1.4	520	M722	310
7MBR75VZ120-80	1200	75	385	1.85	1200	50	1200	1600	75	1.4	520	M722	310
7MBR100VZ120-50	1200	100	520	1.75	1200	75	1200	1600	100	1.5	520	M722	310
7MBR100VZ120-80	1200	100	520	1.75	1200	75	1200	1600	100	1.5	520	M722	310
7MBR150VZ120-50	1200	150	885	1.85	1200	100	1200	1600	150	1.4	780	M722	310
7MBR150VZ120-80	1200	150	885	1.85	1200	100	1200	1600	150	1.4	780	M722	310

Note1: EconoPIM™ is registered trademark of Infineon Technologies AG, Germany.

Note2: "-80" : Pre-Applied Thermal-Interface-Material

$V_{CE(sat)}$, V_{FM} : at $T_{vj}=25^{\circ}C$, Chip

IGBT Module 6-Pack < X series / V series >

6-Pack EconoPACK™ 600V, 1200V class

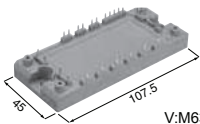
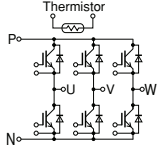
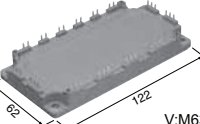
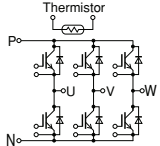
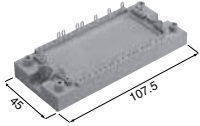
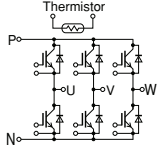
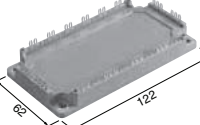
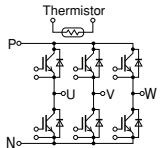
Solder pins	Thermistor	ic	600V		1200V	
			V series	X series	X series	V series
 V:M636, X:M669		50A	6MBI50VA-060-50		6MBI50VA-120-50	
		75A	6MBI75VA-060-50		6MBI75VA-120-50	
		100A	6MBI100VA-060-50	6MBI100XAE120-50	6MBI100VA-120-50	
 V:M633, X:M668		100A		6MBI100XBA120-50	6MBI100VB-120-50	
		150A	6MBI150VB-060-50	6MBI150XBA120-50	6MBI150VB-120-50	
		180A			6MBI180VB-120-50	
		200A		6MBI200XBA120-50	6MBI200XBE120-50	
 M647		50A	6MBI50VW-060-50		6MBI50VW-120-50	
		75A	6MBI75VW-060-50		6MBI75VW-120-50	
		100A	6MBI100VW-060-50		6MBI100VW-120-50	
 M648		100A		6MBI100XXA120-50	6MBI100VX-120-50	
					6MBI100VX-120-80	
		150A	6MBI150VX-060-50	6MBI150XXA120-50	6MBI150VX-120-50	
			6MBI150VX-060-80		6MBI150VX-120-80	
		180A			6MBI180VX-120-50	
					6MBI180VX-120-80	
				6MBI180VX-120-55		
				6MBI180VX-120-85		
		200A		6MBI200XXA120-50		
				6MBI200XXE120-50		

Dimension [mm]

X series

Device type	V _{CES}	V _{GES}	I _C Cont.	P _C	V _{CE(sat)} (V _{GE} =15V)		Switching time			Package	Net mass
					typ.	I _C	t _{d(on)} typ.	t _{d(off)} typ.	t _f typ.		
	Volts	Volts	Amps.	Watts	Volts	Amps.	μ sec.	μ sec.	μ sec.		Grams
○ 6MBI100XAE120-50	1200	±20	100	685	1.45	100	0.23	0.30	0.12	M669	200
● 6MBI100XBA120-50	1200	±20	100	445	1.45	100	0.21	0.29	0.1	M668	310
● 6MBI150XBA120-50	1200	±20	150	625	1.40	150	0.31	0.35	0.15	M668	310
● 6MBI200XBA120-50	1200	±20	200	750	1.45	200	0.27	0.34	0.12	M668	310
● 6MBI200XBE120-50	1200	±20	200	1000	1.45	200	0.27	0.34	0.12	M668	310
● 6MBI100XXA120-50	1200	±20	100	445	1.45	100	0.21	0.29	0.1	M648	310
● 6MBI150XXA120-50	1200	±20	150	625	1.40	150	0.31	0.35	0.15	M648	310
● 6MBI200XXA120-50	1200	±20	200	750	1.45	200	0.27	0.34	0.12	M648	310
● 6MBI200XXE120-50	1200	±20	200	1000	1.45	200	0.27	0.34	0.12	M648	310

V series

Device type	V _{CES}	V _{GES}	I _C Cont.	P _C	V _{CE(sat)} (V _{GE} =15V)		Switching time			Package	Net mass
					typ.	I _C	t _{on} typ.	t _{off} typ.	t _f typ.		
	Volts	Volts	Amps.	Watts	Volts	Amps.	μ sec.	μ sec.	μ sec.		Grams
6MBI50VA-060-50	600	± 20	50	200	1.6	50	0.36	0.52	0.03	M636	180
6MBI75VA-060-50	600	± 20	75	275	1.6	75	0.36	0.52	0.03	M636	180
6MBI100VA-060-50	600	± 20	100	335	1.6	100	0.36	0.52	0.03	M636	180
6MBI150VB-060-50	600	± 20	150	485	1.6	150	0.36	0.52	0.03	M633	300
6MBI50VW-060-50	600	± 20	50	215	1.6	50	0.36	0.52	0.03	M647	200
6MBI75VW-060-50	600	± 20	75	300	1.6	75	0.36	0.52	0.03	M647	200
6MBI100VW-060-50	600	± 20	100	335	1.6	100	0.36	0.52	0.03	M647	200
6MBI150VX-060-50	600	± 20	150	485	1.6	150	0.36	0.52	0.03	M648	310
6MBI150VX-060-80	600	± 20	150	485	1.6	150	0.36	0.52	0.03	M648	310

Note1: EconoPACK™ is registered trademarks of Infineon Technologies AG, Germany.

Note2: 6MBI180VB-120-55, 6MBI180VX-120-55; Premium type ("Low Thermal Impedance Version")

Note3: "-80", "-85": Pre-Applied Thermal-Interface-Material for "-50", "-55"

●: New products ○: Under development

V_{CE(sat)}: at T_{vj}=25°C, Chip



Device type	V_{CES} Volts	V_{GES} Volts	I_C Cont. Amps.	P_C Watts	$V_{CE(sat)}$ ($V_{GE}=15V$)		Switching time			Package	Net mass Grams
					typ. Volts	I_C Amps.	t_{on} typ. μ sec.	t_{off} typ. μ sec.	t_f typ. μ sec.		
6MBI50VA-120-50	1200	± 20	50	280	1.85	50	0.39	0.53	0.06	M636	180
6MBI75VA-120-50	1200	± 20	75	385	1.85	75	0.39	0.53	0.06	M636	180
6MBI100VA-120-50	1200	± 20	100	520	1.75	100	0.39	0.53	0.06	M636	180
6MBI100VB-120-50	1200	± 20	100	520	1.75	100	0.39	0.53	0.06	M633	300
6MBI150VB-120-50	1200	± 20	150	770	1.75	150	0.39	0.53	0.06	M633	300
6MBI180VB-120-50	1200	± 20	150	835	1.85	200	0.39	0.53	0.06	M633	300
6MBI180VB-120-55	1200	± 20	150	1075	1.85	200	0.39	0.53	0.06	M633	300
6MBI50VW-120-50	1200	± 20	50	280	1.85	50	0.39	0.53	0.06	M647	200
6MBI75VW-120-50	1200	± 20	75	385	1.85	75	0.39	0.53	0.06	M647	200
6MBI100VW-120-50	1200	± 20	100	520	1.75	100	0.39	0.53	0.06	M647	200
6MBI100VX-120-50	1200	± 20	100	520	1.75	100	0.39	0.53	0.06	M648	310
6MBI100VX-120-80	1200	± 20	100	520	1.75	100	0.39	0.53	0.06	M648	310
6MBI150VX-120-50	1200	± 20	150	770	1.75	150	0.39	0.53	0.06	M648	310
6MBI150VX-120-80	1200	± 20	150	770	1.75	150	0.39	0.53	0.06	M648	310
6MBI180VX-120-50	1200	± 20	150	835	1.85	200	0.39	0.53	0.06	M648	310
6MBI180VX-120-80	1200	± 20	150	835	1.85	200	0.39	0.53	0.06	M648	310
6MBI180VX-120-55	1200	± 20	150	1075	1.85	200	0.39	0.53	0.06	M648	310
6MBI180VX-120-85	1200	± 20	150	1075	1.85	200	0.39	0.53	0.06	M648	310

Note1: EconoPACK™ is registered trademarks of Infineon Technologies AG, Germany.

Note2: 6MBI180VB-120-55, 6MBI180VX-120-55; Premium type (Low Thermal Impedance Version)

Note3: "-80", "-85" : Pre-Applied Thermal-Interface-Material for "-50", "-55"

$V_{CE(sat)}$: at $T_{vj}=25^\circ C$, Chip

IGBT Module 6-Pack < V series / U series >
6-Pack EconoPACK™ 1700V class

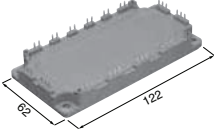
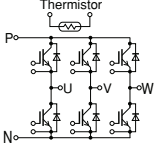
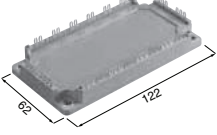
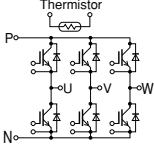
Solder pins		 M633		I_c	1700V	
					V series	U series
				100A		6MBI100U4B-170-50
				150A		6MBI150U4B-170-50
Press fit pins		 M648		100A	1700V	
					V series	U series
					6MBI100VX-170-50	
					6MBI100VX-170-80	

Dimension [mm]

Device type	V_{CES}	V_{GES}	I_c Cont.	P_C	$V_{CE(sat)}$ ($V_{GE}=15V$)		Switching time			Package	Net mass
					typ.	I_c	t_{on} typ.	t_{off} typ.	t_f typ.		
	Volts	Volts	Amps.	Watts	Volts	Amps.	μ sec.	μ sec.	μ sec.		Grams
6MBI100VX-170-50	1700	± 20	100	665	2.00	100	0.63	0.70	0.10	M648	310
6MBI100VX-170-80	1700	± 20	100	665	2.00	100	0.63	0.70	0.10	M648	310
6MBI100U4B-170-50	1700	± 20	100	520	2.25	100	0.62	0.55	0.09	M633	300
6MBI150U4B-170-50	1700	± 20	150	735	2.25	150	0.62	0.55	0.09	M633	300

 Note1: EconoPACK™ is registered trademarks of Infineon Technologies AG, Germany.
 Note2: "-80", "-85" : Pre-Applied Thermal-Interface-Material for "-50", "-55"

 $V_{CE(sat)}$: at $T_{vj}=25^\circ C$, Chip



IGBT Module 6-Pack < V series >

6-Pack EconoPACK™+ 1200V, 1700V class

High power 6-pack

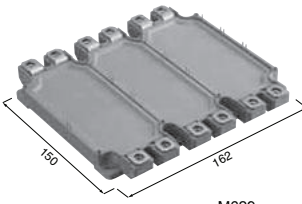
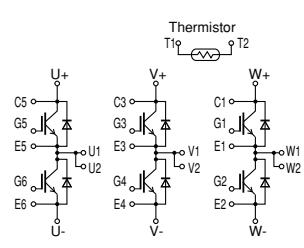
Ic	1200V	1700V
	V series	V series
225A	6MBI225V-120-50	
300A	6MBI300V-120-50	6MBI300V-170-50
	6MBI300V-120-80	
450A	6MBI450V-120-50	6MBI450V-170-50
		6MBI450V-170-80
550A	6MBI550V-120-50	



Dimension [mm]

Device type	V _{CES} Volts	V _{GES} Volts	I _C Cont. Amps.	P _C Watts	V _{CE(sat)} (V _{GE} =15V)		Switching time			Package	Net mass Grams
					typ. Volts	I _C Amps.	t _{on} typ. μ sec.	t _{off} typ. μ sec.	t _f typ. μ sec.		
6MBI225V-120-50	1200	±20	225	1070	1.85	225	0.55	1.05	0.11	M629	950
6MBI300V-120-50	1200	±20	300	1600	1.75	300	0.55	1.05	0.11	M629	950
6MBI300V-120-80	1200	±20	300	1600	1.75	300	0.55	1.05	0.11	M629	950
6MBI450V-120-50	1200	±20	450	2250	1.75	450	0.55	1.05	0.11	M629	950
6MBI550V-120-50	1200	±20	550	2500	1.85	600	0.55	1.05	0.11	M629	950
6MBI300V-170-50	1700	±20	300	1665	2.00	300	0.90	1.30	0.10	M629	950
6MBI450V-170-50	1700	±20	450	2500	2.00	450	0.90	1.30	0.10	M629	950
6MBI450V-170-80	1700	±20	450	2500	2.00	450	0.90	1.30	0.10	M629	950

Note1: EconoPACK™ is registered trademarks of Infineon Technologies AG, Germany.
 Note2: "-80": Pre-Applied Thermal-Interface-Material

V_{CE(sat)}: at T_{vj}=25°C, Chip

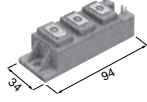
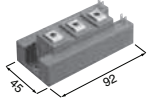
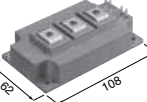
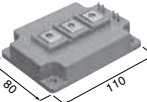
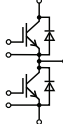
IGBT Module 2-Pack < X series / V series >
Standard 2-Pack 650V, 600V class

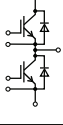
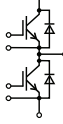
 M263  M274  M275  M277	   	I_C	650V X series	600V V series
		100A		
150A	2MBI150XAA065-50	2MBI150VA-060-50		
200A	2MBI200XAA065-50	2MBI200VA-060-50		
300A	2MBI300XBE065-50	2MBI300VB-060-50		
400A	2MBI400XBE065-50	2MBI400VB-060-50		
400A	2MBI400XDE065-50	2MBI400VD-060-50		
600A	2MBI600XDE065-50	2MBI600VD-060-50		
600A	2MBI600XEE065-50	2MBI600VE-060-50		
		2MBI600VE-060-80		

Dimension [mm]

X series

Device type	V_{CES}	V_{GES}	I_C Cont.	P_C	$V_{CE(sat)}$ ($V_{GE}=15V$)		Switching time			Package	Net mass
					typ.	I_C	$t_{d(on)}$ typ.	$t_{d(off)}$ typ.	t_f typ.		
	Volts	Volts	Amps.	Watts	Volts	Amps.	μ sec.	μ sec.	μ sec.		Grams
● 2MBI150XAA065-50	650	± 20	150	435	1.30	150	0.39	0.38	0.11	M263	180
● 2MBI200XAA065-50	650	± 20	200	545	1.30	200	0.35	0.57	0.07	M263	180
● 2MBI300XBE065-50	650	± 20	300	1160	1.30	300	0.37	0.35	0.07	M274	240
● 2MBI400XBE065-50	650	± 20	400	1740	1.30	400	0.35	0.68	0.07	M274	240
● 2MBI400XDE065-50	650	± 20	400	1945	1.30	400	0.48	0.59	0.07	M275	370
● 2MBI600XDE065-50	650	± 20	600	2795	1.30	600	0.49	0.61	0.11	M275	370
● 2MBI600XEE065-50	650	± 20	600	2795	1.30	600	0.41	0.53	0.11	M277	470

V series

Device type	V_{CES}	V_{GES}	I_C Cont.	P_C	$V_{CE(sat)}$ ($V_{GE}=15V$)		Switching time			Package	Net mass
					typ.	I_C	t_{on} typ.	t_{off} typ.	t_f typ.		
	Volts	Volts	Amps.	Watts	Volts	Amps.	μ sec.	μ sec.	μ sec.		Grams
2MBI100VA-060-50	600	± 20	100	330	1.60	100	0.65	0.60	0.04	M263	180
2MBI150VA-060-50	600	± 20	150	480	1.60	150	0.65	0.60	0.04	M263	180
2MBI200VA-060-50	600	± 20	200	640	1.60	200	0.65	0.60	0.04	M263	180
2MBI300VB-060-50	600	± 20	300	1360	1.60	300	0.65	0.60	0.07	M274	240
2MBI400VB-060-50	600	± 20	400	1970	1.60	400	0.65	0.60	0.07	M274	240
2MBI400VD-060-50	600	± 20	400	1970	1.60	400	0.65	0.60	0.07	M275	370
2MBI600VD-060-50	600	± 20	600	2940	1.60	600	0.75	0.75	0.07	M275	370
2MBI600VE-060-50	600	± 20	600	2940	1.60	600	0.75	0.75	0.07	M277	470
2MBI600VE-060-80	600	± 20	600	2940	1.60	600	0.75	0.75	0.07	M277	470

Note : -80 : Pre-Applied Thermal-Interface-Material

● : New products

 $V_{CE(sat)}$, V_{FM} : at $T_{vj}=25^\circ C$, Chip

IGBT Module 2-Pack < X series / V series >

Standard 2-Pack 1200V class

Image	Model	Circuit Diagram	I _c	1200V	
				X series	V series
	M263		75A		2MBI75VA-120-50
			100A	2MBI100XAA120-50	2MBI100VA-120-50
			150A	2MBI150XAA120-50	2MBI150VA-120-50
			200A	2MBI200XAA120-50	
	M274		150A		2MBI150VB-120-50
			200A	2MBI200XBE120-50	2MBI200VB-120-50
			300A	2MBI300XBE120-50	
	M275		300A		2MBI300VD-120-50
			400A	2MBI400XDE120-50	2MBI400VD-120-50
			600A	2MBI600XDE120-50	
	M276	 * 2MBI450VH-120F-50	200A		2MBI200VH-120-50
					2MBI200VH-120-80
			300A	2MBI300XHA120-50	2MBI300VH-120-50
					2MBI300VH-120-80
			450A	2MBI450XHA120-50	2MBI450VH-120-50
					2MBI450VH-120-80
	M277		600A	2MBI600XHA120-50	2MBI450VH-120F-50
					2MBI450VH-120F-80
			300A		2MBI300VE-120-50
					2MBI300VE-120-80
			450A	2MBI450XEE120-50	2MBI450VE-120-50
					2MBI450VE-120-80
	600A	2MBI600XEE120-50	2MBI600VE-120-50		
			2MBI600VE-120-80		

Dimension [mm]

X series

Device type	V _{CEs}	V _{GES}	I _c Cont.	P _C	V _{CE(sat)} (V _{GE} =15V)		Switching time			Package	Net mass
					typ.	I _c	t _{d(on)} typ.	t _{d(off)} typ.	t _f typ.		
	Volts	Volts	Amps.	Watts	Volts	Amps.	μ sec.	μ sec.	μ sec.		Grams
● 2MBI100XAA120-50	1200	±20	100	460	1.40	100	0.34	0.33	0.12	M263	180
● 2MBI150XAA120-50	1200	±20	150	575	1.50	150	0.25	0.32	0.16	M263	180
● 2MBI200XAA120-50	1200	±20	200	735	1.45	200	0.34	0.32	0.07	M263	180
● 2MBI200XBE120-50	1200	±20	200	1150	1.40	200	0.32	0.36	0.13	M274	240
● 2MBI300XBE120-50	1200	±20	300	1760	1.50	300	0.23	0.35	0.11	M274	240
● 2MBI400XDE120-50	1200	±20	400	2975	1.40	400	0.30	0.39	0.12	M275	370
● 2MBI600XDE120-50	1200	±20	600	3985	1.45	600	0.30	0.39	0.15	M275	370
● 2MBI300XHA120-50	1200	±20	300	1475	1.45	300	0.37	0.39	0.15	M276	370
● 2MBI450XHA120-50	1200	±20	450	1850	1.45	450	0.30	0.39	0.12	M276	370
● 2MBI600XHA120-50	1200	±20	600	2340	1.45	600	0.30	0.39	0.12	M276	370
● 2MBI450XEE120-50	1200	±20	450	2975	1.45	450	0.33	0.45	0.10	M277	470
● 2MBI600XEE120-50	1200	±20	600	3985	1.40	600	0.33	0.45	0.11	M277	470

● : New products

V_{CE(sat)}: at T_{vj}=25°C, Chip



■ V series

Device type	V _{CES} Volts	V _{GES} Volts	I _C Cont. Amps.	P _C Watts	V _{CE(sat)} (V _{GE} =15V)		Switching time			Package	Net mass Grams
					typ. Volts	I _C Amps.	t _{on} typ. μ sec.	t _{off} typ. μ sec.	t _f typ. μ sec.		
2MBI75VA-120-50	1200	±20	75	390	1.85	75	0.60	0.60	0.04	M263	180
2MBI100VA-120-50	1200	±20	100	555	1.85	100	0.60	0.60	0.04	M263	180
2MBI150VA-120-50	1200	±20	150	785	1.85	150	0.60	0.60	0.04	M263	180
2MBI150VB-120-50	1200	±20	150	1070	1.85	150	0.60	0.80	0.08	M274	240
2MBI200VB-120-50	1200	±20	200	1500	1.75	200	0.60	0.80	0.08	M274	240
2MBI300VD-120-50	1200	±20	300	2200	1.85	300	0.60	0.80	0.08	M275	380
2MBI400VD-120-50	1200	±20	400	3330	1.75	400	0.60	0.80	0.08	M275	380
2MBI200VH-120-50	1200	±20	200	1110	1.75	200	0.60	0.80	0.08	M276	370
2MBI200VH-120-80	1200	±20	200	1110	1.75	200	0.60	0.80	0.08	M276	370
2MBI300VH-120-50	1200	±20	300	1600	1.75	300	0.60	0.80	0.08	M276	370
2MBI300VH-120-80	1200	±20	300	1600	1.75	300	0.60	0.80	0.08	M276	370
2MBI450VH-120-50	1200	±20	450	2400	1.80	450	0.60	0.80	0.08	M276	370
2MBI450VH-120-80	1200	±20	450	2400	1.80	450	0.60	0.80	0.08	M276	370
2MBI450VH-120F-50	1200	±20	450	2400	1.80	450	0.60	0.80	0.08	M276	370
2MBI450VH-120F-80	1200	±20	450	2400	1.80	450	0.60	0.80	0.08	M276	370
2MBI300VE-120-50	1200	±20	300	2200	1.85	300	0.60	0.80	0.08	M277	470
2MBI300VE-120-80	1200	±20	300	2200	1.85	300	0.60	0.80	0.08	M277	470
2MBI450VE-120-50	1200	±20	450	3350	1.80	450	0.60	0.80	0.08	M277	470
2MBI450VE-120-80	1200	±20	450	3350	1.80	450	0.60	0.80	0.08	M277	470
2MBI600VE-120-50	1200	±20	600	4800	1.75	600	0.60	0.80	0.08	M277	470
2MBI600VE-120-80	1200	±20	600	4800	1.75	600	0.60	0.80	0.08	M277	470

Note : -80 : Pre-Applied Thermal-Interface-Material

V_{CE(sat)}: at T_{vj}=25°C, Chip



IGBT Module 2-Pack < X series / V series >

Standard 2-Pack 1700V class

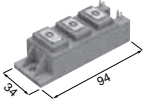
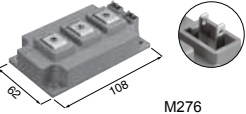
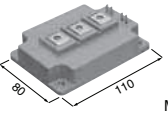
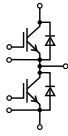
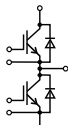
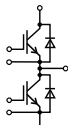
 M263  M276  M277	  	I_c	1700V	
			X series	V series
		75A	2MBI75XAA170-50	2MBI75VA-170-50
		100A	2MBI100XAA170-50	2MBI100VA-170-50
		150A	2MBI150XAA170-50	
		200A		
		150A	2MBI150XHA170-50	2MBI150VH-170-50
				2MBI150VH-170-80
		200A	2MBI200XHA170-50	2MBI200VH-170-50
				2MBI200VH-170-80
		300A	2MBI300XHA170-50	2MBI300VH-170-50
				2MBI300VH-170-80
		400A	2MBI400XHA170-50	
		300A	2MBI300XEE170-50	2MBI300VE-170-50
				2MBI300VE-170-80
		400A	2MBI400XEE170-50	2MBI400VE-170-50
				2MBI400VE-170-80

Dimension [mm]

X series

Device type	V_{CES}	V_{GES}	I_c Cont.	P_C	$V_{CE(sat)}$ ($V_{GE}=15V$)		Switching time			Package	Net mass
					typ.	I_c	$t_{d(on)}$ typ.	$t_{d(off)}$ typ.	t_f typ.		
	Volts	Volts	Amps.	Watts	Volts	Amps.	μ sec.	μ sec.	μ sec.		Grams
○ 2MBI75XAA170-50	1700	± 20	75	TBD	TBD	75	TBD	TBD	TBD	M263	180
○ 2MBI100XAA170-50	1700	± 20	100	TBD	TBD	100	TBD	TBD	TBD	M263	180
○ 2MBI150XAA170-50	1700	± 20	150	TBD	TBD	150	TBD	TBD	TBD	M263	180
○ 2MBI150XHA170-50	1700	± 20	150	TBD	TBD	150	TBD	TBD	TBD	M276	370
○ 2MBI200XHA170-50	1700	± 20	200	TBD	TBD	200	TBD	TBD	TBD	M276	370
○ 2MBI300XHA170-50	1700	± 20	300	TBD	TBD	300	TBD	TBD	TBD	M276	370
○ 2MBI400XHA170-50	1700	± 20	400	TBD	TBD	400	TBD	TBD	TBD	M276	370
○ 2MBI300XEE170-50	1700	± 20	300	TBD	TBD	300	TBD	TBD	TBD	M277	470
○ 2MBI400XEE170-50	1700	± 20	400	TBD	TBD	400	TBD	TBD	TBD	M277	470

V series

Device type	V_{CES}	V_{GES}	I_c Cont.	P_C	$V_{CE(sat)}$ ($V_{GE}=15V$)		Switching time			Package	Net mass
					typ.	I_c	t_{on} typ.	t_{off} typ.	t_f typ.		
	Volts	Volts	Amps.	Watts	Volts	Amps.	μ sec.	μ sec.	μ sec.		Grams
2MBI75VA-170-50	1700	± 20	75	555	2.00	75	1.25	1.30	0.15	M263	180
2MBI100VA-170-50	1700	± 20	100	665	2.00	100	1.25	1.30	0.15	M263	180
2MBI150VH-170-50	1700	± 20	150	1110	2.00	150	0.95	1.05	0.14	M276	370
2MBI150VH-170-80	1700	± 20	150	1110	2.00	150	0.95	1.05	0.14	M276	370
2MBI200VH-170-50	1700	± 20	200	1250	2.00	200	1.15	1.05	0.14	M276	370
2MBI200VH-170-80	1700	± 20	200	1250	2.00	200	1.15	1.05	0.14	M276	370
2MBI300VH-170-50	1700	± 20	300	1805	2.00	300	1.15	1.05	0.14	M276	370
2MBI300VH-170-80	1700	± 20	300	1805	2.00	300	1.15	1.05	0.14	M276	370
2MBI300VE-170-50	1700	± 20	300	2830	2.00	300	1.15	1.05	0.14	M277	470
2MBI300VE-170-80	1700	± 20	300	2830	2.00	300	1.15	1.05	0.14	M277	470
2MBI400VE-170-50	1700	± 20	400	3840	2.00	400	1.15	1.05	0.14	M277	470
2MBI400VE-170-80	1700	± 20	400	3840	2.00	400	1.15	1.05	0.14	M277	470

Note : -80 : Pre-Applied Thermal-Interface-Material
 ○ : Under development

$V_{CE(sat)}$, V_{FM} : at $T_{vj}=25^\circ C$, Chip

IGBT Module 2-Pack < X series / V series >

Standard 2-Pack 1200V class

Solder pins	M254	Thermistor	ic	1200V		
				X series	V series	V series With SIN-substrate
Solder pins	M285 *2	Thermistor	225A	2MBI225XNA120-50	2MBI225VN-120-50 2MBI225VN-120-80	2MBI225VN-120S-50
			300A	2MBI300XNA120-50	2MBI300VN-120-50 2MBI300VN-120-80	2MBI300VN-120S-50 2MBI300VN-120S-80
			450A	2MBI450XNA120-50	2MBI450VN-120-50 2MBI450VN-120-80	2MBI450VN-120S-50 2MBI450VN-120S-80
			600A	2MBI600XNG120-50		2MBI600VN-120-50 2MBI600VN-120-80
Press fit pins	M282	Thermistor	225A	2MBI225XNB120-50	2MBI225VX-120-50 2MBI225VX-120-80	
			300A	2MBI300XNB120-50	2MBI300VX-120-50 2MBI300VX-120-80	
Press fit pins	M286 *2	Thermistor	450A	2MBI450XNB120-50	2MBI450VX-120-50 2MBI450VX-120-80	
			600A	2MBI600XNH120-50		2MBI600VX-120-50 2MBI600VX-120-80
			600A	2MBI600XNF120-50		
			800A	2MBI800XNF120-50		
Spring contacts	M260	Thermistor	225A		2MBI225VJ-120-50 2MBI225VJ-120-80	
			300A		2MBI300VJ-120-50 2MBI300VJ-120-80	
			450A		2MBI450VJ-120-50 2MBI450VJ-120-80	
			600A			2MBI600VJ-120-50 2MBI600VJ-120-80

Dimension [mm]

X series

Device type	V _{CE(S)} Volts	V _{GE(S)} Volts	I _C Cont. Amps.	P _C Watts	V _{CE(sat)} (V _{GE} =15V)		Switching time			Package	Net mass Grams
					typ.	I _C Amps.	t _{d(on)} typ. μ sec.	t _{d(off)} typ. μ sec.	t _f typ. μ sec.		
○ 2MBI225XNA120-50	1200	±20	225	1030	1.45	225	0.23	0.33	0.05	M254	350
○ 2MBI300XNA120-50	1200	±20	300	1325	1.40	300	0.26	0.36	0.05	M254	350
○ 2MBI450XNA120-50	1200	±20	450	1760	1.40	450	0.37	0.40	0.07	M254	350
○ 2MBI600XNG120-50*1	1200	±20	600	3125	1.45	600	0.42	0.42	0.07	M254	350
● 2MBI600XNE120-50*1	1200	±20	600	3125	1.45	600	0.42	0.42	0.07	M285*2	350
● 2MBI800XNE120-50*1	1200	±20	800	4050	1.45	800	0.47	0.45	0.08	M285*2	350
○ 2MBI225XNB120-50	1200	±20	225	1030	1.45	225	0.23	0.33	0.05	M282	350
○ 2MBI300XNB120-50	1200	±20	300	1325	1.40	300	0.26	0.36	0.05	M282	350
○ 2MBI450XNB120-50	1200	±20	450	1760	1.40	450	0.37	0.40	0.07	M282	350
○ 2MBI600XNH120-50*1	1200	±20	600	3125	1.45	600	0.42	0.42	0.07	M282	350
○ 2MBI600XNF120-50*1	1200	±20	600	3125	1.45	600	0.42	0.42	0.07	M286*2	350
○ 2MBI800XNF120-50*1	1200	±20	800	4050	1.45	800	0.47	0.45	0.08	M286*2	350

*1: The products with 'XNE, XNF, XNG, XNH': Low Thermal Impedance Version

V_{CE(sat)}: at T_{vj}=25°C, Chip

*2: Low thermal impedance and high tracking capability type

*3: The products with 'S': Low Thermal Impedance Version

●: New products ○: Under development

■ V series

Device type	V_{CES}	V_{GES}	I_C Cont.	P_C	$V_{CE(sat)}$ ($V_{GE}=15V$)		Switching time			Package	Net mass
	Volts	Volts			Volts	Amps.	t_{on} typ.	t_{off} typ.	t_f typ.		
			I_C	I_C						$\mu sec.$	$\mu sec.$
2MBI225VN-120-50	1200	±20	225	1070	1.85	225	0.55	1.05	0.11	M254	350
2MBI225VN-120-80	1200	±20	225	1070	1.85	225	0.55	1.05	0.11	M254	350
2MBI225VN-120S-50*3	1200	±20	225	1360	1.85	225	0.40	0.55	0.05	M254	350
2MBI300VN-120-50	1200	±20	300	1595	1.75	300	0.55	1.05	0.11	M254	350
2MBI300VN-120-80	1200	±20	300	1595	1.75	300	0.55	1.05	0.11	M254	350
2MBI300VN-120S-50*3	1200	±20	300	2000	1.75	300	0.45	0.65	0.06	M254	350
2MBI300VN-120S-80*3	1200	±20	300	2000	1.75	300	0.45	0.65	0.06	M254	350
2MBI450VN-120-50	1200	±20	450	2270	1.75	450	0.55	1.05	0.11	M254	350
2MBI450VN-120-80	1200	±20	450	2270	1.75	450	0.55	1.05	0.11	M254	350
2MBI450VN-120S-50*3	1200	±20	450	3000	1.75	450	0.47	0.70	0.07	M254	350
2MBI450VN-120S-80*3	1200	±20	450	3000	1.75	450	0.47	0.70	0.07	M254	350
2MBI600VN-120-50	1200	±20	600	3750	1.85	600	0.55	1.05	0.11	M254	350
2MBI600VN-120-80	1200	±20	600	3750	1.85	600	0.55	1.05	0.11	M254	350
2MBI225VX-120-50	1200	±20	225	1070	1.85	225	0.55	1.05	0.11	M282	350
2MBI225VX-120-80	1200	±20	225	1070	1.85	225	0.55	1.05	0.11	M282	350
2MBI300VX-120-50	1200	±20	300	1595	1.75	300	0.55	1.05	0.11	M282	350
2MBI300VX-120-80	1200	±20	300	1595	1.75	300	0.55	1.05	0.11	M282	350
2MBI450VX-120-50	1200	±20	450	2270	1.75	450	0.55	1.05	0.11	M282	350
2MBI450VX-120-80	1200	±20	450	1595	1.75	450	0.55	1.05	0.11	M282	350
2MBI600VX-120-50	1200	±20	600	3750	1.85	600	0.55	1.05	0.11	M282	350
2MBI600VX-120-80	1200	±20	600	3750	1.85	600	0.55	1.05	0.11	M282	350
2MBI225VJ-120-50	1200	±20	225	1070	1.85	225	0.55	1.05	0.11	M260	360
2MBI225VJ-120-80	1200	±20	225	1070	1.85	225	0.55	1.05	0.11	M260	360
2MBI300VJ-120-50	1200	±20	300	1595	1.75	300	0.55	1.05	0.11	M260	360
2MBI300VJ-120-80	1200	±20	300	1595	1.75	300	0.55	1.05	0.11	M260	360
2MBI450VJ-120-50	1200	±20	450	2270	1.75	450	0.55	1.05	0.11	M260	360
2MBI450VJ-120-80	1200	±20	450	2270	1.75	450	0.55	1.05	0.11	M260	360
2MBI600VJ-120-50	1200	±20	600	3750	1.85	600	0.55	1.05	0.11	M260	360
2MBI600VJ-120-80	1200	±20	600	3750	1.85	600	0.55	1.05	0.11	M260	360

*1: The products with 'XNE, XNF, XNG, XNH' : Low Thermal Impedance Version

*2: Low thermal impedance and high tracking capability type

*3: The products with 'S' : Low Thermal Impedance Version

Note: -80 : Pre-Applied Thermal-Interface-Material

 $V_{CE(sat)}$: at $T_{vj}=25^{\circ}C$, Chip

IGBT Module 2-Pack < X series / V series >

Standard 2-Pack 1700V class

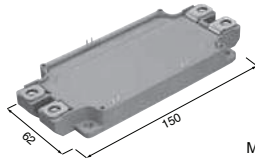
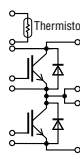
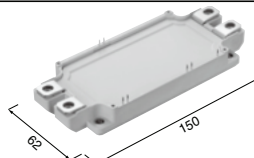
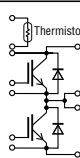
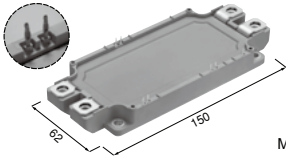
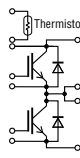
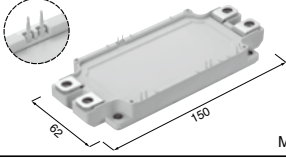
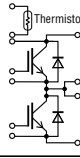
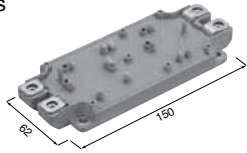
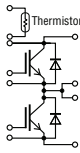
Solder pins			I_c	1700V		
				X series	V series	V series With SIN-substrate
			225A	2MBI225XNA170-50		
			300A	2MBI300XNA170-50	2MBI300VN-170-50 2MBI300VN-170-80	
			450A	2MBI450XNA170-50	2MBI450VN-170-50 2MBI450VN-170-80	
			550A			2MBI550VN-170-50 2MBI550VN-170-80
			600A	2MBI600XNG170-50		
Solder pins			600A	2MBI600XNE170-50		
Press fit pins			225A	2MBI225XNB170-50	2MBI225VX-170-50 2MBI225VX-170-80	
			300A	2MBI300XNB170-50	2MBI300VX-170-50 2MBI300VX-170-80	
			450A	2MBI450XNB170-50	2MBI450VX-170-50 2MBI450VX-170-80	
			550A			2MBI550VX-170-50 2MBI550VX-170-80
			600A	2MBI600XNH170-50		
Press fit pins			600A	2MBI600XNF170-50		
Spring contacts			550A			2MBI550VJ-170-50 2MBI550VJ-170-80

Dimension [mm]

X series

Device type	V_{CES}	V_{GES}	I_c Cont.	P_C	$V_{CE(sat)}$ ($V_{GE}=15V$)		Switching time			Package	Net mass
					typ.	I_c	$t_{d(on)}$ typ.	$t_{d(off)}$ typ.	t_f typ.		
	Volts	Volts	Amps.	Watts	Volts	Amps.	μ sec.	μ sec.	μ sec.		Grams
○ 2MBI225XNA170-50	1700	± 20	225	TBD	TBD	225	TBD	TBD	TBD	M254	350
○ 2MBI300XNA170-50	1700	± 20	300	TBD	TBD	300	TBD	TBD	TBD	M254	350
○ 2MBI450XNA170-50	1700	± 20	450	TBD	TBD	450	TBD	TBD	TBD	M254	350
○ 2MBI600XNG170-50*1	1700	± 20	450	TBD	TBD	450	TBD	TBD	TBD	M254	350
○ 2MBI600XNE170-50*1	1700	± 20	600	TBD	TBD	600	TBD	TBD	TBD	M285*2	350
○ 2MBI225XNB170-50	1700	± 20	225	TBD	TBD	225	TBD	TBD	TBD	M282	350
○ 2MBI300XNB170-50	1700	± 20	300	TBD	TBD	300	TBD	TBD	TBD	M282	350
○ 2MBI450XNB170-50	1700	± 20	450	TBD	TBD	450	TBD	TBD	TBD	M282	350
○ 2MBI600XNH170-50*1	1700	± 20	450	TBD	TBD	450	TBD	TBD	TBD	M282	350
○ 2MBI600XNF170-50*1	1700	± 20	600	TBD	TBD	600	TBD	TBD	TBD	M286*2	350

*1: The products with 'XNE, XNF, XNG, XNH' : Low Thermal Impedance Version

$V_{CE(sat)}$: at $T_{vj}=25^\circ C$, Chip

*2: Low thermal impedance and high tracking capability type

*3: 550A Low Thermal Impedance Version

○: Under development

■ V series

Device type	V _{CES} Volts	V _{GES} Volts	I _C Cont. Amps.	P _C Watts	V _{CE(sat)} (V _{GE} =15V)		Switching time			Package	Net mass Grams
					typ. Volts	I _C Amps.	t _{on} typ. μ sec.	t _{off} typ. μ sec.	t _f typ. μ sec.		
2MBI300VN-170-50	1700	±20	300	1665	2.00	300	0.90	1.30	0.10	M254	350
2MBI300VN-170-80	1700	±20	300	1665	2.00	300	0.90	1.30	0.10	M254	350
2MBI450VN-170-50	1700	±20	450	2500	2.00	450	0.90	1.30	0.10	M254	350
2MBI450VN-170-80	1700	±20	450	2500	2.00	450	0.90	1.30	0.10	M254	350
2MBI550VN-170-50*³	1700	±20	550	3750	2.15	550	1.00	1.30	0.10	M254	350
2MBI550VN-170-80*³	1700	±20	550	3750	2.15	550	1.00	1.30	0.10	M254	350
2MBI225VX-170-50	1700	±20	225	1500	2.00	225	0.90	1.05	0.08	M282	350
2MBI225VX-170-80	1700	±20	225	1500	2.00	225	0.90	1.05	0.08	M282	350
2MBI300VX-170-50	1700	±20	300	1665	2.00	300	0.90	1.30	0.10	M282	350
2MBI300VX-170-80	1700	±20	300	1665	2.00	300	0.90	1.30	0.10	M282	350
2MBI450VX-170-50	1700	±20	450	2500	2.00	450	0.90	1.30	0.10	M282	350
2MBI450VX-170-80	1700	±20	450	2500	2.00	450	0.90	1.30	0.10	M282	350
2MBI550VX-170-50*³	1700	±20	550	3750	2.15	550	1.00	1.30	0.10	M282	350
2MBI550VX-170-80*³	1700	±20	550	3750	2.15	550	1.00	1.30	0.10	M282	350
2MBI550VJ-170-50*³	1700	±20	550	3750	2.15	550	1.00	1.30	0.10	M260	360
2MBI550VJ-170-80*³	1700	±20	550	3750	2.15	550	1.00	1.30	0.10	M260	360

*1: The products with 'S' : Low Thermal Impedance Version

*2: Low thermal impedance and high tracking capability type

*3: 550A Low Thermal Impedance Version

Note: -80 : Pre-Applied Thermal-Interface-Material

V_{CE(sat)}: at T_{vj}=25°C, Chip



IGBT Module 2-Pack < X series >

High Power Module HPnC 1700V, 3300V class

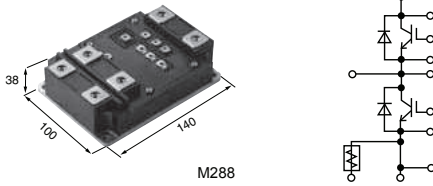
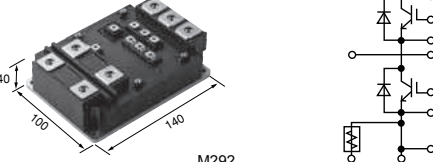
	I_c	1700V	3300V
		X series	X series
 <p>M288</p>	450A		2MBI450XUF330-50
	1000A	2MBI1000XUF170-50	
 <p>M292</p>	450A		2MBI450XVF330-50
	1000A	2MBI1000XVF170-50	

Dimension [mm]

Device type	V_{CES}	V_{GES}	I_c Cont.	P_C	$V_{CE(sat)}$ ($V_{GE}=15V$)		Switching time			Package	Net mass
					typ.	I_c	$t_{d(on)}$ typ.	$t_{d(off)}$ typ.	t_f typ.		
	Volts	Volts	Amps.	Watts	Volts	Amps.	μ sec.	μ sec.	μ sec.		Grams
○ 2MBI1000XUF170-50	1700	± 20	1000	4340	1.7	1000	0.75	1.3	0.6	M288	670
○ 2MBI1000XVF170-50	1700	± 20	1000	4340	1.7	1000	0.75	1.3	0.6	M292	720
○ 2MBI450XUF330-50	3300	± 20	450	TBD	TBD	450	TBD	TBD	TBD	M288	670
○ 2MBI450XVF330-50	3300	± 20	450	TBD	TBD	450	TBD	TBD	TBD	M292	720

○ : Under development

Note: M288 and M292 are different in the dimensions of the output terminal.

$V_{CE(sat)}$, V_{FM} : at $T_{vj}=25^\circ C$, Chip



IGBT Module 2-Pack < V series >

High Power Module 1200V, 1700V class

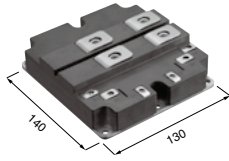

M256, M278

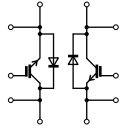

I_C	1200V	1700V	
	V series	V series	
	Cu-baseplate	Cu-baseplate	AlSiC-baseplate
600A	2MBI600VG-120P	2MBI600VG-170E	2MBI600VT-170E
800A	2MBI800VG-120P	2MBI800VG-170E	2MBI800VT-170E
1200A	2MBI1200VG-120P	2MBI1200VG-170E	2MBI1200VT-170E

Dimension [mm]

Device type	V_{CES} Volts	V_{GES} Volts	I_C Cont. Amps.	P_C Watts	$V_{CE(sat)}$ ($V_{GE}=15V$)		Switching time			Package	Net mass Grams
					typ.	I_C Amps.	t_{on} typ. μ sec.	t_{off} typ. μ sec.	t_f typ. μ sec.		
2MBI600VG-120P	1200	± 20	600	3940	1.70	600	1.86	1.25	0.12	M256	1500
2MBI800VG-120P	1200	± 20	800	5170	1.70	800	1.97	1.33	0.15	M256	1500
2MBI1200VG-120P	1200	± 20	1200	6810	1.70	1200	2.55	1.67	0.16	M256	1500
2MBI600VG-170E	1700	± 20	600	4410	2.00	600	2.28	2.07	0.58	M256	1500
2MBI800VG-170E	1700	± 20	800	5760	2.00	800	2.41	2.13	0.55	M256	1500
2MBI1200VG-170E	1700	± 20	1200	7500	2.00	1200	2.76	2.29	0.33	M256	1500
2MBI600VT-170E	1700	± 20	600	4280	2.00	600	1.51	2.07	0.58	M278	900
2MBI800VT-170E	1700	± 20	800	5370	2.00	800	2.00	2.13	0.55	M278	900
2MBI1200VT-170E	1700	± 20	1200	7040	2.00	1200	2.14	2.29	0.33	M278	900

Note: M256: Cu-baseplate M278: AlSiC-baseplate

$V_{CE(sat)}$: at $T_{vj}=25^\circ C$, Chip Switching time: at $T_{vj}=125^\circ C$

IGBT Module 2-Pack < X series / V series >

PrimePACK™ 1200V class

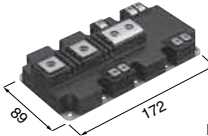
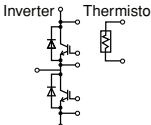
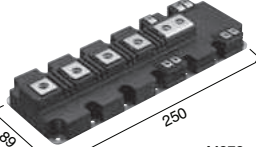
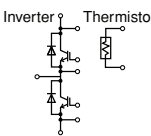
		1200V			
		X series		V series	
		Low switching loss	Soft turn off	Low switching loss	Soft turn off
 M271 	I_C				
	600A			2MBI600VXA-120E-50	
				2MBI600VXA-120E-80	
 M272 					
	900A	2MBI900XXA120E-50	2MBI900XXA120P-50	2MBI900VXA-120E-50	2MBI900VXA-120P-50
				2MBI900VXA-120E-80	2MBI900VXA-120P-80
			2MBI900VXA-120E-54	2MBI900VXA-120P-54	
	1200A	2MBI1200XXE120E-50	2MBI1200XXE120P-50		
	1400A		2MBI1400XVB120P-50	2MBI1400VXB-120E-50	2MBI1400VXB-120P-50
				2MBI1400VXB-120E-80	2MBI1400VXB-120P-80
			2MBI1400VXB-120E-54	2MBI1400VXB-120P-54	
	1800A		2MBI1800XF120P-50		

Dimension [mm]

X series

Device type	V_{CES}	V_{GES}	I_C Cont.	P_C	$V_{CE(sat)}$ ($V_{GE}=15V$)		Switching time			Package	Net mass
					typ.	I_C	$t_{d(on)}$ typ.	$t_{d(off)}$ typ.	t_f typ.		
	Volts	Volts	Amps.	Watts	Volts	Amps.	μ sec.	μ sec.	μ sec.		Grams
○ 2MBI900XXA120E-50	1200	±20	900	TBD	TBD	900	TBD	TBD	TBD	M271	850
○ 2MBI900XXA120P-50	1200	±20	900	TBD	TBD	900	TBD	TBD	TBD	M271	850
○ 2MBI1200XXE120E-50	1200	±20	1200	TBD	TBD	1200	TBD	TBD	TBD	M271	850
○ 2MBI1200XXE120P-50	1200	±20	1200	TBD	TBD	1200	TBD	TBD	TBD	M271	850
○ 2MBI1400XVB120P-50	1200	±20	1400	TBD	TBD	1400	TBD	TBD	TBD	M272	1250
○ 2MBI1800XF120P-50	1200	±20	1800	TBD	TBD	1800	TBD	TBD	TBD	M272	1250

V series

Device type	V_{CES}	V_{GES}	I_C Cont.	P_C	$V_{CE(sat)}$ ($V_{GE}=15V$)		Switching time			Package	Net mass
					typ.	I_C	t_{on} typ.	t_{off} typ.	t_f typ.		
	Volts	Volts	Amps.	Watts	Volts	Amps.	μ sec.	μ sec.	μ sec.		Grams
2MBI600VXA-120E-50	1200	±20	600	3350	1.75	600	1.00	1.20	0.15	M271	850
2MBI600VXA-120E-80	1200	±20	600	3350	1.75	600	1.00	1.20	0.15	M271	850
2MBI600VXA-120E-54	1200	±20	600	3350	1.75	600	1.00	1.20	0.15	M271	850
2MBI900VXA-120E-50	1200	±20	900	5100	1.75	900	1.00	1.20	0.15	M271	850
2MBI900VXA-120E-80	1200	±20	900	5100	1.75	900	1.00	1.20	0.15	M271	850
2MBI900VXA-120E-54	1200	±20	900	5100	1.75	900	1.00	1.20	0.15	M271	850
2MBI1400VXB-120E-50	1200	±20	1400	7650	1.75	1400	1.00	1.20	0.15	M272	1250
2MBI1400VXB-120E-80	1200	±20	1400	7650	1.75	1400	1.00	1.20	0.15	M272	1250
2MBI1400VXB-120E-54	1200	±20	1400	7650	1.75	1400	1.00	1.20	0.15	M272	1250
2MBI900VXA-120P-50	1200	±20	900	5100	1.65	900	1.00	1.20	0.15	M271	850
2MBI900VXA-120P-80	1200	±20	900	5100	1.65	900	1.00	1.20	0.15	M271	850
2MBI900VXA-120P-54	1200	±20	900	5100	1.65	900	1.00	1.20	0.15	M271	850
2MBI1400VXB-120P-50	1200	±20	1400	7650	1.65	1400	1.00	1.20	0.15	M272	1250
2MBI1400VXB-120P-80	1200	±20	1400	7650	1.65	1400	1.00	1.20	0.15	M272	1250
2MBI1400VXB-120P-54	1200	±20	1400	7650	1.65	1400	1.00	1.20	0.15	M272	1250

Note 1: PrimePACK™ is registered trademark of Infineon Technologies AG, Germany.

Note 2: The products with suffix "-54" on this page are labeled to specify the rank of $V_{CE(sat)}$ and V_f .

Note 3: "-80": Pre-Applied Thermal-Interface-Material for "-54"

○ : Under development

$V_{CE(sat)}$: at $T_V=25^\circ\text{C}$, Chip



IGBT Module 2-Pack < X series / V series >

PrimePACK™ 1700V class

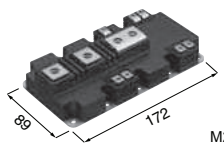
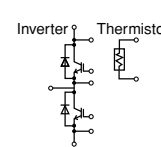
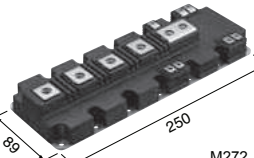
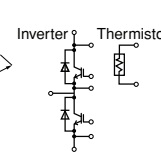
		1700V			
		X series	V series		
		Low switching loss	Low switching loss	Soft turn off	
 M271		650A	2MBI650XXA170-50	2MBI650VXA-170E-50	
				2MBI650VXA-170E-80	
				2MBI650VXA-170E-54	
				2MBI650VXA-170EA-50	
				2MBI650VXA-170EA-80	
				2MBI650VXA-170EA-54	
				2MBI1200XXE170-50	
 M272		1000A	2MBI1000XXB170-50	2MBI1000VXB-170E-50	
				2MBI1000VXB-170E-80	
				2MBI1000VXB-170E-54	
				2MBI1000VXB-170EA-50	
				2MBI1000VXB-170EA-80	
				2MBI1000VXB-170EA-54	
		1400A	2MBI1400XXB170-50	2MBI1400VXB-170E-50	2MBI1400VXB-170P-50
				2MBI1400VXB-170E-80	2MBI1400VXB-170P-80
				2MBI1400VXB-170E-54	2MBI1400VXB-170P-54
1800A	2MBI1800XXF170-50				

Dimension [mm]

X series

Device type	V _{CE(s)}	V _{GES}	I _c Cont.	P _C	V _{CE(sat)} (V _{GE} =15V)		Switching time			Package	Net mass
					typ.	I _c	t _{d(on)} typ.	t _{d(off)} typ.	t _f typ.		
○ 2MBI650XXA170-50	1700	±20	650	TBD	TBD	650	TBD	TBD	TBD	M271	850
○ 2MBI1200XXE170-50	1700	±20	1200	TBD	TBD	1200	TBD	TBD	TBD	M271	850
○ 2MBI1000XXB170-50	1700	±20	1000	TBD	TBD	1000	TBD	TBD	TBD	M272	1250
○ 2MBI1400XXB170-50	1700	±20	1400	TBD	TBD	1400	TBD	TBD	TBD	M272	1250
○ 2MBI1800XXF170-50	1700	±20	1800	TBD	TBD	1800	TBD	TBD	TBD	M272	1250

V series

Device type	V _{CE(s)}	V _{GES}	I _c Cont.	P _C	V _{CE(sat)} (V _{GE} =15V)		Switching time			Package	Net mass
					typ.	I _c	t _{on} typ.	t _{off} typ.	t _f typ.		
2MBI650VXA-170E-50	1700	±20	650	4150	2.00	650	1.25	1.55	0.15	M271	850
2MBI650VXA-170E-80	1700	±20	650	4150	2.00	650	1.25	1.55	0.15	M271	850
2MBI650VXA-170E-54	1700	±20	650	4150	2.00	650	1.25	1.55	0.15	M271	850
2MBI650VXA-170EA-50	1700	±20	650	4150	2.00	650	1.70	1.60	0.11	M271	850
2MBI650VXA-170EA-80	1700	±20	650	4150	2.00	650	1.70	1.60	0.11	M271	850
2MBI650VXA-170EA-54	1700	±20	650	4150	2.00	650	1.70	1.60	0.11	M271	850
2MBI1000VXB-170E-50	1700	±20	1000	6250	2.00	1000	1.25	1.55	0.15	M272	1250
2MBI1000VXB-170E-80	1700	±20	1000	6250	2.00	1000	1.25	1.55	0.15	M272	1250
2MBI1000VXB-170E-54	1700	±20	1000	6250	2.00	1000	1.25	1.55	0.15	M272	1250
2MBI1000VXB-170EA-50	1700	±20	1000	6250	2.00	1000	1.70	1.60	0.11	M272	1250
2MBI1000VXB-170EA-80	1700	±20	1000	6250	2.00	1000	1.70	1.60	0.11	M272	1250
2MBI1000VXB-170EA-54	1700	±20	1000	6250	2.00	1000	1.70	1.60	0.11	M272	1250
2MBI1400VXB-170E-50	1700	±20	1400	8820	2.15	1400	1.25	1.55	0.15	M272	1250
2MBI1400VXB-170E-80	1700	±20	1400	8820	2.15	1400	1.25	1.55	0.15	M272	1250
2MBI1400VXB-170E-54	1700	±20	1400	8820	2.15	1400	1.25	1.55	0.15	M272	1250
2MBI1400VXB-170P-50	1700	±20	1400	8820	1.90	1400	1.35	1.80	0.20	M272	1250
2MBI1400VXB-170P-80	1700	±20	1400	8820	1.90	1400	1.35	1.80	0.20	M272	1250
2MBI1400VXB-170P-54	1700	±20	1400	8820	1.90	1400	1.35	1.80	0.20	M272	1250

Note 1: PrimePACK™ is registered trademark of Infineon Technologies AG, Germany.

Note 2: The products with suffix '-54' on this page are labeled to specify the rank of V_{CE(sat)} and V_f.

Note 3: The products with 'EA' on this page have optimized FWD for the application causing heavy load through FWD.

The optimized FWD reduces V_f and thermal resistance.

Note 4: "-80": Pre-Applied Thermal-Interface-Material for "-54"

○ : Under development

V_{CE(sat)} at T_{Vj}=25°C, Chip

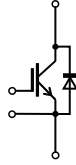
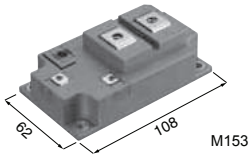
IGBT Module 1-Pack < V series >
Standard 1-Pack 1200V, 1700V class

I_c	1200V		1700V
	V series		
	Aluminium oxide DCB	Aluminium nitride DCB	Aluminium oxide DCB
300A			1MBI300V-170-50
400A	1MBI400V-120-50	1MBI400VF-120-50	1MBI400V-170-50
600A	1MBI600V-120-50	1MBI600VF-120-50	1MBI600V-170-50
900A	1MBI900V-120-50		

Dimension [mm]

Device type	V_{CES}	V_{GES}	I_c Cont.	P_C Watts	$V_{CE(sat)}$ ($V_{GE}=15V$)		Switching time			Package	Net mass Grams
	Volts	Volts			Volts	I_c Amps.	t_{on} typ. μ sec.	t_{off} typ. μ sec.	t_f typ. μ sec.		
1MBI400V-120-50	1200	± 20	400	2410	1.75	400	0.60	1.10	0.14	M153	380
1MBI600V-120-50	1200	± 20	600	3000	1.75	600	0.70	0.90	0.10	M153	380
1MBI900V-120-50	1200	± 20	900	4280	1.90	900	0.70	0.85	0.10	M153	380
1MBI400VF-120-50	1200	± 20	400	3330	1.75	400	0.60	1.10	0.14	M153	380
1MBI600VF-120-50	1200	± 20	600	4680	1.75	600	0.70	0.90	0.10	M153	380
1MBI300V-170-50	1700	± 20	300	1705	2.00	300	0.70	0.80	0.14	M153	380
1MBI400V-170-50	1700	± 20	400	2500	2.00	400	0.70	0.80	0.14	M153	380
1MBI600V-170-50	1700	± 20	600	3610	2.00	600	0.70	0.80	0.14	M153	380

 $V_{CE(sat)}$: at $T_{vj}=25^\circ C$, Chip



IGBT Module 1-Pack < V series / U series >

High Power Module 1200V, 1700V, 3300V class

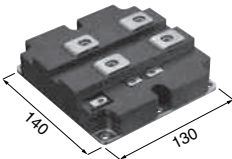
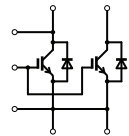
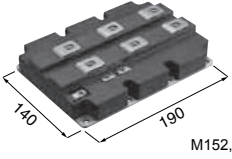
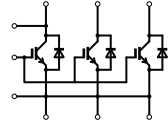
 <p>M151, M155</p>		<i>I_c</i>	1200V	1700V		3300V
			V series	V series		U series
			Cu-baseplate	Cu-baseplate	AlSiC-baseplate	AlSiC-baseplate
		800A				1MBI800UG-330
		1000A				1MBI1000UG-330 1MBI1000UG-330B
1200A	1MBI1200VC-120P	1MBI1200VC-170E	1MBI1200VR-170E			
1600A	1MBI1600VC-120P	1MBI1600VC-170E	1MBI1600VR-170E			
2400A	1MBI2400VC-120P	1MBI2400VC-170E	1MBI2400VR-170E			
 <p>M152, M156</p>		1200A			1MBI1200UE-330	
		1500A			1MBI1500UE-330 1MBI1500UE-330B	
		2400A	1MBI2400VD-120P	1MBI2400VD-170E	1MBI2400VS-170E	
		3600A	1MBI3600VD-120P	1MBI3600VD-170E	1MBI3600VS-170E	

Dimension [mm]

Device type	<i>V_{CEs}</i>	<i>V_{GES}</i>	<i>I_c</i> Cont.	<i>P_C</i>	<i>V_{CE(sat)}</i> (<i>V_{GE}</i> =15V)		Switching time			Package	Net mass Grams
					typ.	<i>I_c</i>	<i>t_{on}</i> typ.	<i>t_{off}</i> typ.	<i>t_f</i> typ.		
	Volts	Volts	Amps.	Watts	Volts	Amps.	μ sec.	μ sec.	μ sec.		
1MBI1200VC-120P	1200	±20	1200	7890	1.70	1200	1.73	1.52	0.15	M151	1500
1MBI1600VC-120P	1200	±20	1600	10340	1.70	1600	2.22	1.47	0.19	M151	1500
1MBI2400VC-120P	1200	±20	2400	13630	1.70	2400	3.15	1.93	0.24	M151	1500
1MBI2400VD-120P	1200	±20	2400	15780	1.70	2400	2.38	1.64	0.21	M152	2300
1MBI3600VD-120P	1200	±20	3600	20540	1.70	3600	2.98	2.15	0.27	M152	2300
1MBI1200VC-170E	1700	±20	1200	8820	2.00	1200	2.18	2.20	0.45	M151	1500
1MBI1600VC-170E	1700	±20	1600	11700	2.00	1600	2.28	2.17	0.40	M151	1500
1MBI2400VC-170E	1700	±20	2400	15000	2.00	2400	2.63	2.41	0.38	M151	1500
1MBI2400VD-170E	1700	±20	2400	17640	2.00	2400	2.30	2.22	0.43	M152	2300
1MBI3600VD-170E	1700	±20	3600	22380	2.00	3600	2.27	2.67	0.31	M152	2300
1MBI1200VR-170E	1700	±20	1200	8570	2.00	1200	1.51	2.20	0.45	M155	900
1MBI1600VR-170E	1700	±20	1600	10710	2.00	1600	1.83	2.17	0.40	M155	900
1MBI2400VR-170E	1700	±20	2400	14010	2.00	2400	2.51	2.41	0.38	M155	900
1MBI2400VS-170E	1700	±20	2400	16120	2.00	2400	2.09	2.22	0.43	M156	1300
1MBI3600VS-170E	1700	±20	3600	21120	2.00	3600	2.70	2.66	0.32	M156	1300
1MBI800UG-330	3300	±20	800	9600	2.28	800	3.40	2.40	0.40	M155	900
1MBI1000UG-330	3300	±20	1000	10400	2.46	1000	2.50	2.00	0.50	M155	900
1MBI1000UG-330B	3300	±20	1000	10400	2.75	1000	3.10	2.35	0.45	M155	900
1MBI1200UE-330	3300	±20	1200	14700	2.28	1200	3.40	2.40	0.40	M156	1300
1MBI1500UE-330	3300	±20	1500	15600	2.46	1500	3.10	2.60	0.50	M156	1300
1MBI1500UE-330B	3300	±20	1500	15600	2.75	1500	3.10	2.35	0.45	M156	1300

Note1: M151, M152: Cu-baseplate M155, M156: AlSiC-baseplate
 Note2: -330B type: Low switching losses

V_{CE(sat)}: at *T_{vj}*=25°C, Chip *V_{CE(sat)}*: at *T_{vj}*=125°C, at *T_{vj}*=150°C (3300V-1000A, 1500A only)

IGBT Module Chopper < V series / U series >
Chopper 600V, 1200V class

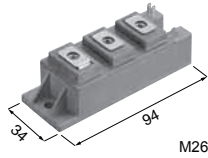
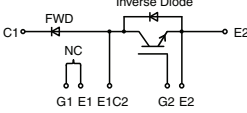
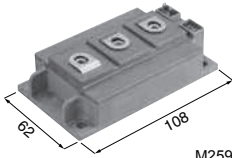
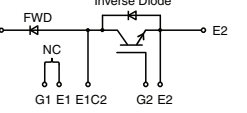
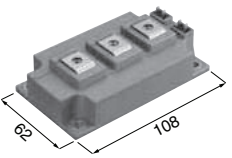
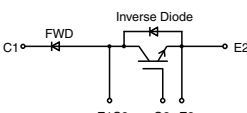
	I_c	600V		1200V	
		U series	V series	U series	V series
 <p>M262</p> 	50A			1MBI50U4F-120L-50	
	75A			1MBI75U4F-120L-50	
	100A			1MBI100U4F-120L-50	
	150A				1MBI150VA-120L-50
	200A				1MBI200VA-120L-50
 <p>M259</p> 	200A			1MBI200U4H-120L-50	
	300A	1MBI300U2H-060L-50			
 <p>M283</p> 	400A		1MBI400VH-060L-50		

Dimension [mm]

Device type	V_{CES}	V_{GES}	I_c	P_C	$V_{CE(sat)}$ ($V_{GE}=15V$)		Switching time			Package	Net mass
					typ.	I_c	t_{on}	t_{off}	t_f		
	Volts	Volts	Amps.	Watts	Volts	Amps.	μ sec.	μ sec.	μ sec.		Grams
1MBI300U2H-060L-50	600	± 20	300	1000	2.45	300	0.40	0.48	0.07	M259	360
1MBI400VH-060L-50	600	± 20	400	1250	1.60	400	0.73	0.61	0.07	M283	370
1MBI50U4F-120L-50	1200	± 20	50	400	2.15	50	0.32	0.41	0.07	M262	180
1MBI75U4F-120L-50	1200	± 20	75	400	2.20	75	0.32	0.41	0.07	M262	180
1MBI100U4F-120L-50	1200	± 20	100	540	2.20	100	0.32	0.41	0.07	M262	180
1MBI200U4H-120L-50	1200	± 20	200	1040	2.25	200	0.32	0.41	0.07	M259	360
1MBI150VA-120L-50	1200	± 20	150	785	1.85	150	0.60	0.60	0.04	M262	180
1MBI200VA-120L-50	1200	± 20	200	880	1.80	200	0.60	0.60	0.04	M262	180

 $V_{CE(sat)}$: at $T_{vj}=25^\circ C$, Chip



IGBT Module Chopper < V series >

PrimePACK™ 1200V, 1700V class

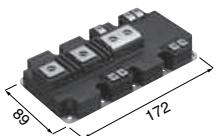
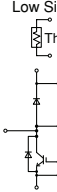
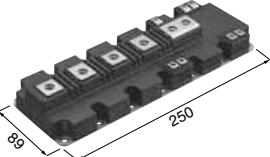
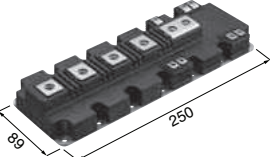
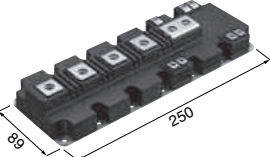
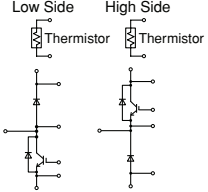
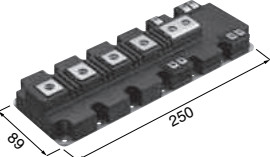
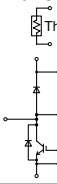
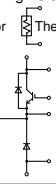
Chopper	 M271	 Low Side Thermistor	 High Side Thermistor	1200V		1700V		
				V series				
				Low side configuration	High side configuration	Low side configuration	High side configuration	
Chopper	 M272	 Low Side Thermistor	 High Side Thermistor	650A			1MBI650VXA-170EL-50	1MBI650VXA-170EH-50
							1MBI650VXA-170EL-80	1MBI650VXA-170EH-80
Chopper	 M272	 Low Side Thermistor	 High Side Thermistor	1000A			1MBI1000VXB-170EL-50	1MBI1000VXB-170EH-50
							1MBI1000VXB-170EL-80	1MBI1000VXB-170EH-80
							1MBI1000VXB-170EL-54	1MBI1000VXB-170EH-54
				1400A	1MBI1400VXB-120PL-54	1MBI1400VXB-120PH-54	1MBI1400VXB-170PL-50	1MBI1400VXB-170PH-50
	1MBI1400VXB-120PL-80	1MBI1400VXB-120PH-80	1MBI1400VXB-170PL-54	1MBI1400VXB-170PH-54				

Dimension [mm]

Device type	V _{CEs}	V _{GES}	I _c Cont.	P _C	V _{CE(sat)} (V _{GE} =15V)		Switching time			Package	Net mass
					typ.	I _c	t _{on} typ.	t _{off} typ.	t _f typ.		
	Volts	Volts	Amps.	Watts	Volts	Amps.	μ sec.	μ sec.	μ sec.		Grams
1MBI1400VXB-120PL-54	1200	±20	1400	7650	1.65	1400	1.00	1.20	0.15	M272	1250
1MBI1400VXB-120PL-80	1200	±20	1400	7650	1.65	1400	1.00	1.20	0.15	M272	1250
1MBI1400VXB-120PH-54	1200	±20	1400	7650	1.65	1400	1.00	1.20	0.15	M272	1250
1MBI1400VXB-120PH-80	1200	±20	1400	7650	1.65	1400	1.00	1.20	0.15	M272	1250
1MBI650VXA-170EL-50	1700	±20	650	4150	2.00	650	1.25	1.55	0.15	M271	850
1MBI650VXA-170EL-80	1700	±20	650	4150	2.00	650	1.25	1.55	0.15	M271	850
1MBI650VXA-170EL-54	1700	±20	650	4150	2.00	650	1.25	1.55	0.15	M271	850
1MBI1000VXB-170EL-50	1700	±20	1000	6250	2.00	1000	1.25	1.55	0.15	M272	1250
1MBI1000VXB-170EL-80	1700	±20	1000	6250	2.00	1000	1.25	1.55	0.15	M272	1250
1MBI1000VXB-170EL-54	1700	±20	1000	6250	2.00	1000	1.25	1.55	0.15	M272	1250
1MBI1400VXB-170PL-50	1700	±20	1400	8820	2.15	1400	1.25	1.55	0.15	M272	1250
1MBI1400VXB-170PL-54	1700	±20	1400	8820	2.15	1400	1.25	1.55	0.15	M272	1250
1MBI650VXA-170EH-50	1700	±20	650	4150	2.00	650	1.25	1.55	0.15	M271	850
1MBI650VXA-170EH-80	1700	±20	650	4150	2.00	650	1.25	1.55	0.15	M271	850
1MBI650VXA-170EH-54	1700	±20	650	4150	2.00	650	1.25	1.55	0.15	M271	850
1MBI1000VXB-170EH-50	1700	±20	1000	6250	2.00	1000	1.25	1.55	0.15	M272	1250
1MBI1000VXB-170EH-80	1700	±20	1000	6250	2.00	1000	1.25	1.55	0.15	M272	1250
1MBI1000VXB-170EH-54	1700	±20	1000	6250	2.00	1000	1.25	1.55	0.15	M272	1250
1MBI1400VXB-170PH-50	1700	±20	1400	8820	2.15	1400	1.25	1.55	0.15	M272	1250
1MBI1400VXB-170PH-54	1700	±20	1400	8820	2.15	1400	1.25	1.55	0.15	M272	1250







Note1: PrimePACK™ is registered trademark of Infineon Technologies AG, Germany.

Note2: The products with suffix '-54' on this page are labeled to specify the rank of V_{CE(sat)} and V_f.

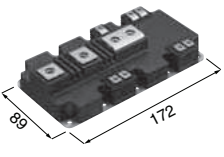
Note3: "-80": Pre-Applied Thermal-Interface-Material for "-54"

V_{CE(sat)}: at T_{vj}=25°C, Chip

IGBT Module Chopper < V series >

Chopper		1200V		
		V series		
 M271	Low Side	High Side	<i>I_c</i>	
			Boost (Low side) Chopper	Buck (High side) Chopper
			1MBI900VXA-120PD-50	1MBI900VXA-120PC-50
			1MBI900VXA-120PD-54	1MBI900VXA-120PC-54
			1MBI900VXA-120PD-80	1MBI900VXA-120PC-80

Dimension [mm]

Device type	V_{CES}	V_{GES}	I_c Cont.	P_C	$V_{CE(sat)}$ ($V_{GE}=15V$)		Switching time			Package	Net mass
					typ.	I_c	t_{on} typ.	t_{off} typ.	t_f typ.		
	Volts	Volts	Amps.	Watts	Volts	Amps.	μ sec.	μ sec.	μ sec.		Grams
1MBI900VXA-120PC-50	1200	± 20	900	5100	1.65	900	1.10	1.20	0.15	M271	850
1MBI900VXA-120PC-54	1200	± 20	900	5100	1.65	900	1.10	1.20	0.15	M271	850
1MBI900VXA-120PC-80	1200	± 20	900	5100	1.65	900	1.10	1.20	0.15	M271	850
1MBI900VXA-120PD-50	1200	± 20	900	5100	1.65	900	1.10	1.20	0.15	M271	850
1MBI900VXA-120PD-54	1200	± 20	900	5100	1.65	900	1.10	1.20	0.15	M271	850
1MBI900VXA-120PD-80	1200	± 20	900	5100	1.65	900	1.10	1.20	0.15	M271	850

Note1: PrimePACK™ is registered trademark of Infineon Technologies AG, Germany.

 $V_{CE(sat)}$: at $T_{vj}=25^\circ C$, Chip

 Note2: The products with suffix '-54' on this page are labeled to specify the rank of $V_{CE(sat)}$ and V_f .

Note3: Antiparallel diode current rating is 120A. Application circuit is Boost/Buck chopper only.

Note4: "-80": Pre-Applied Thermal-Interface-Material for "-54"

IGBT Module High Speed

High Speed 1200V class

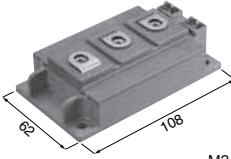
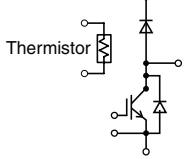
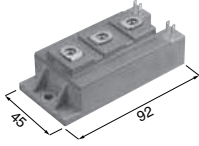
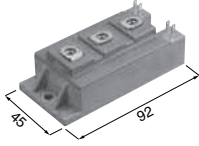
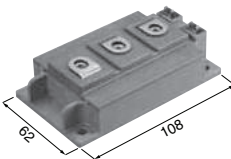
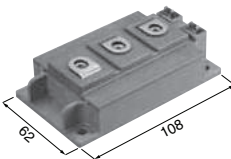
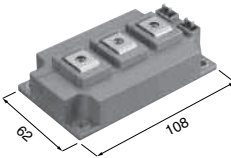
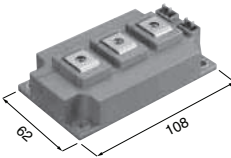
Chopper				I_c	1200V High Speed IGBT
 M249		200A		1MBI200HH-120L-50	
		300A		1MBI300HH-120L-50	
		400A		1MBI400HH-120L-50	
2-pack				100A	2MBI100HB-120-50
 M233					
2-pack				150A	2MBI150HH-120-50
 M249		200A		2MBI200HH-120-50	
2-pack				100A	2MBI100HJ-120-50
 M276		150A		2MBI150HJ-120-50	
		200A		2MBI200HJ-120-50	
		300A		2MBI300HJ-120-50	

Dimension [mm]

Device type	V_{CES} Volts	V_{GES} Volts	I_c Cont. Amps.	P_C Watts	$V_{CE(sat)}$ ($V_{GE}=15V$)		Switching time			Package	Net mass Grams
					typ.	I_c Amps.	t_{on} typ. $\mu sec.$	t_{off} typ. $\mu sec.$	t_f typ. $\mu sec.$		
1MBI200HH-120L-50	1200	± 20	200	1390	3.10	200	0.2	0.3	0.05	M249	370
1MBI300HH-120L-50	1200	± 20	300	2090	3.20	300	0.2	0.3	0.05	M249	370
1MBI400HH-120L-50	1200	± 20	400	2500	3.10	400	0.2	0.4	0.05	M249	370
2MBI100HB-120-50	1200	± 20	100	1040	3.10	100	-	0.30	0.05	M233	240
2MBI150HH-120-50	1200	± 20	150	1390	3.20	150	-	0.30	0.05	M249	370
2MBI200HH-120-50	1200	± 20	200	1790	3.10	200	-	0.30	0.05	M249	370
2MBI100HJ-120-50	1200	± 20	100	655	3.20	100	0.25	0.30	0.05	M276	370
2MBI150HJ-120-50	1200	± 20	150	925	3.20	150	0.25	0.30	0.05	M276	370
2MBI200HJ-120-50	1200	± 20	200	1385	3.20	200	0.25	0.30	0.05	M276	370
2MBI300HJ-120-50	1200	± 20	300	1950	3.20	300	0.25	0.30	0.05	M276	370

$V_{CE(sat)}$: at $T_{vj}=25^\circ C$, Chip

IGBT Module 3-level < V series >

T/I-type NPC 3-level Circuits 600V, 1200V, 1700V class

Features

- Applicable to T/I-type NPC 3-level circuit, for high power conversion efficiency.
- There are 1-leg or 3-leg (3 phase) circuits in one package and it is easier to make external wiring of module.
- Lower surge voltage by smaller internal package stray inductance.
- Lower power loss can be achieved by using RB-IGBT*3 as for T-type AC-SW device.
- Lowest power loss can be achieved by using 6th Gen. IGBT and FWD as for Main-SW device.

1-leg T-Type	T1, T2	600V	1200V	1700V
	T3, T4	600V	900V	1200V
	220A			4MBI220VF-170R2-50 4MBI220VF-170R2-60
	300A		4MBI300VG-120R-50	4MBI300VG-120R1-50
	340A		4MBI340VF-120R-50	
	400A	4MBI400VG-060R-50	4MBI400VF-120R-50*1	
	450A		4MBI450VF-120RD-50*2	
	450A		4MBI450VB-120R1-50 4MBI450VB-120R1-60	4MBI450VB-170R2-50 4MBI450VB-170R2-60
	600A			4MBI600VB-170R2-50 4MBI600VB-170R2-60
	650A		4MBI650VB-120R1-50 4MBI650VB-120R1-60	
	900A		4MBI900VB-120RA-50 4MBI900VB-120RA-60	4MBI900VB-120R1-50 4MBI900VB-120R1-60
	600A			4MBI600VC-120-50 4MBI600VC-120-60

Dimension [mm]

Device type	T1, T2			$V_{CE(sat)}$ ($V_{GE}=15V$)		T3, T4			$V_{CE(sat)}$ ($V_{GE}=15V$)		Package	Net mass Grams
	V_{CES}	I_C	P_C	typ.	I_C	V_{CES}	I_C	P_C	typ.	I_C		
	Volts	Amps.	Watts	Volts	Amps.	Volts	Amps.	Watts	Volts	Amps.		
4MBI400VG-060R-50	600	400	1135	1.60	400	600	400	1560	2.45	400	M403	460
4MBI300VG-120R-50	1200	300	1250	1.85	300	600	300	1250	2.45	300	M403	460
4MBI300VG-120R1-50	1200	300	1500	1.85	300	900	300	1550	2.30	300	M403	460
4MBI340VF-120R-50	1200	340	1500	1.85	300	600	340	1500	2.45	300	M403	460
4MBI400VF-120R-50*1	1200	400	1835	2.00	400	600	450	2230	2.45	400	M403	460
4MBI450VF-120RD-50*2	1200	250	1250	1.75	200	600	450	2230	2.45	400	M403	460
4MBI450VB-120R1-50	1200	450	2205	1.85	450	900	450	1980	2.30	450	M404	1300
4MBI450VB-120R1-60	1200	450	2205	1.85	450	900	450	1980	2.30	450	M404	1300
4MBI650VB-120R1-50	1200	650	3060	1.80	650	900	650	2660	2.25	650	M404	1300
4MBI650VB-120R1-60	1200	650	3060	1.80	650	900	650	2660	2.25	650	M404	1300
4MBI900VB-120R1-50	1200	900	3950	1.85	900	900	900	3675	2.30	900	M404	1300
4MBI900VB-120R1-60	1200	900	3950	1.85	900	900	900	3675	2.30	900	M404	1300
4MBI900VB-120RA-50	1200	900	3950	1.85	900	600	900	2660	2.45	900	M404	1300
4MBI900VB-120RA-60	1200	900	3950	1.85	900	600	900	2660	2.45	900	M404	1300
4MBI600VC-120-50	1200	600	2460	1.85	600	1200	600	2460	1.85	600	M404	1300
4MBI600VC-120-60	1200	600	2460	1.85	600	1200	600	2460	1.85	600	M404	1300
4MBI220VF-170R2-50	1700	220	1500	2.00	200	1200	220	1865	2.70	200	M403	460
4MBI220VF-170R2-60	1700	220	1500	2.00	200	1200	220	1865	2.70	200	M403	460
4MBI450VB-170R2-50	1700	450	2830	2.00	450	1200	450	2660	2.70	450	M404	1300
4MBI450VB-170R2-60	1700	450	2830	2.00	450	1200	450	2660	2.70	450	M404	1300
4MBI600VB-170R2-50	1700	600	3410	2.00	600	1200	600	3680	2.70	600	M404	1300
4MBI600VB-170R2-60	1700	600	3410	2.00	600	1200	600	3680	2.70	600	M404	1300

●: New products ○: Under development

Note 1: VF type is lower thermal impedance version.

Note 2: The products with suffix '-60' on this page are labeled the characteristic data.

*1: Particular for Inverter *2: Particular for Converter *3: RB-IGBT Reverse-Blocking IGBT, which has reverse blocking capability (between emitter and collector)

$V_{CE(sat)}$: at $T_{vj}=25^{\circ}C$, Chip

IGBT Module 3-level < V series >

T/I-type NPC 3-level Circuits 1200V class

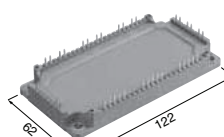
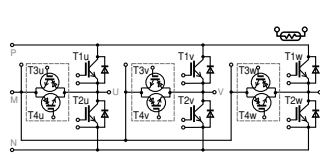
3-leg Solder pins		T1, T2		1200V	
		T3, T4		600V	
 M1203		50A	12MBI50VN-120-50		
		75A	12MBI75VN-120-50		
		100A	12MBI100VN-120-50		
3-leg Press fit pins		50A	12MBI50VX-120-50		
		75A	12MBI75VX-120-50		
		100A	12MBI100VX-120-50		

Dimension [mm]

Device type	T1, T2					T3, T4					Package	Net mass Grams
	V_{CES}	I_C	P_C	$V_{CE(sat)}$	$V_{GE=15V}$	V_{CES}	I_C	P_C	$V_{CE(sat)}$ ($V_{GE=15V}$)			
	Volts	Cont. Amps.	Watts	typ. Volts	I_C Amps.	Volts	Cont. Amps.	Watts	typ. Volts	I_C Amps.		
12MBI50VN-120-50	1200	50	230	1.85	50	600	50	235	2.45	50	M1203	302
12MBI75VN-120-50	1200	75	320	1.85	75	600	75	305	2.45	75	M1203	302
12MBI100VN-120-50	1200	100	430	1.75	100	600	100	400	2.45	100	M1203	302
12MBI50VX-120-50	1200	50	230	1.85	50	600	50	235	2.45	50	M1202	302
12MBI75VX-120-50	1200	75	320	1.85	75	600	75	305	2.45	75	M1202	302
12MBI100VX-120-50	1200	100	430	1.75	100	600	100	400	2.45	100	M1202	302

$V_{CE(sat)}$: at $T_{vj}=25^{\circ}\text{C}$, Chip

IGBT Module IPM < X series >

Small IPM (Intelligent Power Module) 600V class

- Built-in protection functions**
- P-side fault status output (Alarm)
 - N-side fault status output (Alarm)
 - Under voltage protection (self shutdown)
 - Over current protection (External current detection and shutdown)
 - Overheating protection (self shutdown)
 - Temperature sensor output (Vtemp, out)

Small IPM with High Voltage Driver-*I_c* without Brake-Chopper

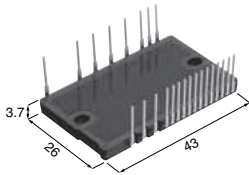

P633A

						600V	
						X series	
						<i>I_c</i>	
	✓	✓	✓	✓		15A	6MBP15XSD060-50
						20A	6MBP20XSD060-50
						30A	6MBP30XSD060-50
						35A	6MBP35XSD060-50
	✓	✓	✓	✓		15A	6MBP15XSF060-50
						20A	6MBP20XSF060-50
						30A	6MBP30XSF060-50
						35A	6MBP35XSF060-50

Dimension [mm]

Device type	Inverter			Control								Package	Net mass
	<i>V_{CE(sat)}</i>	<i>I_c</i>	<i>V_{CE(sat)}</i>	<i>V_{CCL}</i>	Boot-strap	Input signal	Protection function				<i>V_F</i> -O fault output		
	Volts	Amps.	Volts	<i>V_{CCH}</i>	Diode	Active logic and Voltage level	UV	OC	<i>V_{temp}</i>	TOH			
● 6MBP15XSD060-50	600	15	1.60	15	Built-in	High(3.3/5V)	P&N-side	N-side	N-side	-	N-side(UV,OC)	P633A	9.3
● 6MBP20XSD060-50	600	20	1.60	15	Built-in	High(3.3/5V)	P&N-side	N-side	N-side	-	N-side(UV,OC)	P633A	9.3
● 6MBP30XSD060-50	600	30	1.60	15	Built-in	High(3.3/5V)	P&N-side	N-side	N-side	-	N-side(UV,OC)	P633A	9.3
● 6MBP35XSD060-50	600	35	1.40	15	Built-in	High(3.3/5V)	P&N-side	N-side	N-side	-	N-side(UV,OC)	P633A	9.3
● 6MBP15XSF060-50	600	15	1.60	15	Built-in	High(3.3/5V)	P&N-side	N-side	N-side	N-side(143±7°C)	N-side(UV,OC,TOH)	P633A	9.3
● 6MBP20XSF060-50	600	20	1.60	15	Built-in	High(3.3/5V)	P&N-side	N-side	N-side	N-side(143±7°C)	N-side(UV,OC,TOH)	P633A	9.3
● 6MBP30XSF060-50	600	30	1.60	15	Built-in	High(3.3/5V)	P&N-side	N-side	N-side	N-side(143±7°C)	N-side(UV,OC,TOH)	P633A	9.3
● 6MBP35XSF060-50	600	35	1.40	15	Built-in	High(3.3/5V)	P&N-side	N-side	N-side	N-side(143±7°C)	N-side(UV,OC,TOH)	P633A	9.3

●: New Products

*1: External current detection

*2: Temperature detection in LVIC

Block Diagram

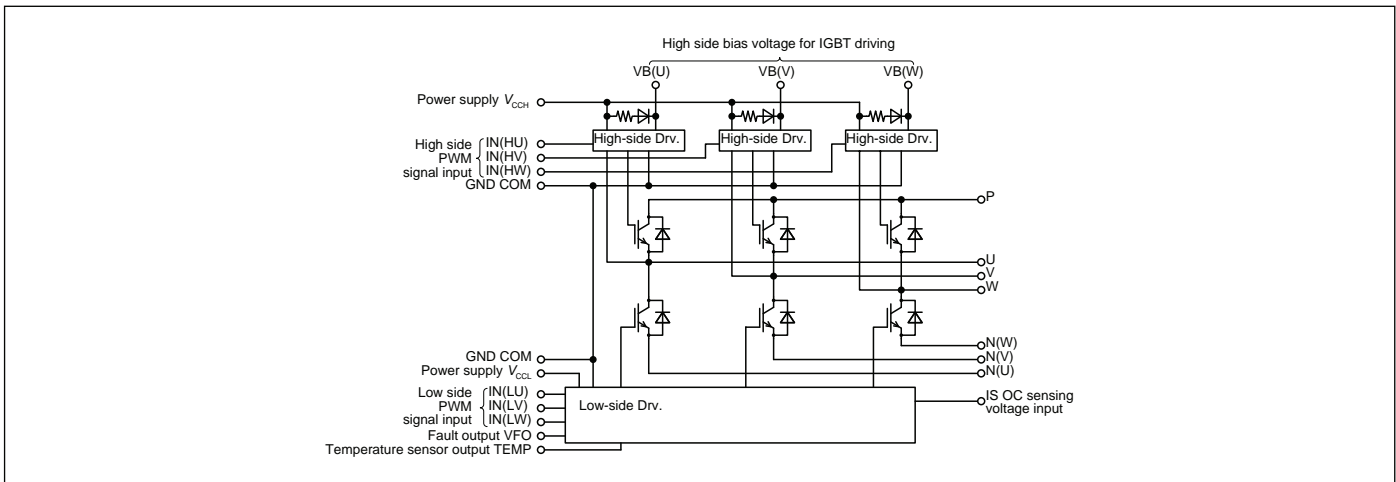



IGBT Module IPM < V series >

IPM (Intelligent Power Module) 600V, 1200V class

Built-in protection functions

- P-side fault status output (Alarm)
- N-side fault status output (Alarm)
- Under voltage protection (self shutdown)
- Over current protection (self shutdown)
- Overheating protection (self shutdown)

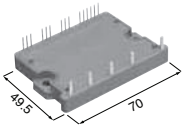
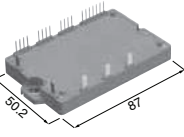
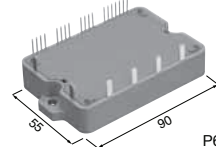
						600V		1200V	
						V series		V series	
						Without Brake-Chopper	With Brake-Chopper	Without Brake-Chopper	With Brake-Chopper
 P629	✓	✓	✓	✓	<i>I_c</i>				
					10A			6MBP10VAA120-50	
					15A			6MBP15VAA120-50	
					20A	6MBP20VAA060-50			
					25A			6MBP25VAA120-50	
					30A	6MBP30VAA060-50			
 P626	✓	✓	✓	✓	25A			6MBP25VBA120-50	
					35A			6MBP35VBA120-50	
					50A	6MBP50VBA060-50		6MBP50VBA120-50	
					75A	6MBP75VBA060-50			
 P636	✓	✓	✓	✓	25A			6MBP25VFN120-50	7MBP25VFN120-50
					35A			6MBP35VFN120-50	7MBP35VFN120-50
					50A	6MBP50VFN060-50	7MBP50VFN060-50	6MBP50VFN120-50	7MBP50VFN120-50
					75A	6MBP75VFN060-50	7MBP75VFN060-50		
					100A	6MBP100VFN060-50	7MBP100VFN060-50		

Dimension [mm]

Device type	Inverter			Brake		Control				Alarm signal hold time			Package	Net mass Grams
	<i>V_{CES}</i>	<i>I_c</i>	<i>V_{CE(sat)}</i>	<i>V_{CES}</i>	<i>I_c</i>	<i>V_{CC}</i>	<i>I_{OC}[INV]</i>	<i>V_{UV}</i>	<i>T_{JOH}</i>	OC typ.	UV typ.	<i>T_{JOH}</i> typ.		
	Volts	Amps.	Volts	Volts	Amps.	Volts	Amps.	Volts	°C	ms	ms	ms		
6MBP20VAA060-50	600	20	1.4	-	-	15	30	11.0 to 12.5	150	2	4	8	P629	80
6MBP30VAA060-50	600	30	1.4	-	-	15	45	11.0 to 12.5	150	2	4	8	P629	80
6MBP50VAA060-50	600	50	1.4	-	-	15	75	11.0 to 12.5	150	2	4	8	P629	80
6MBP50VBA060-50	600	50	1.4	-	-	15	75	11.0 to 12.5	150	2	4	8	P626	100
6MBP75VBA060-50	600	75	1.4	-	-	15	113	11.0 to 12.5	150	2	4	8	P626	100
6MBP50VFN060-50	600	50	1.25	-	-	15	100	11.0 to 12.5	150	2	4	8	P636	190
6MBP75VFN060-50	600	75	1.25	-	-	15	150	11.0 to 12.5	150	2	4	8	P636	190
6MBP100VFN060-50	600	100	1.25	-	-	15	200	11.0 to 12.5	150	2	4	8	P636	190
7MBP50VFN060-50	600	50	1.25	600	30	15	100	11.0 to 12.5	150	2	4	8	P636	190
7MBP75VFN060-50	600	75	1.25	600	50	15	150	11.0 to 12.5	150	2	4	8	P636	190
7MBP100VFN060-50	600	100	1.25	600	50	15	200	11.0 to 12.5	150	2	4	8	P636	190
6MBP10VAA120-50	1200	10	1.7	-	-	15	15	11.0 to 12.5	150	2	4	8	P629	80
6MBP15VAA120-50	1200	15	1.7	-	-	15	23	11.0 to 12.5	150	2	4	8	P629	80
6MBP25VAA120-50	1200	25	1.7	-	-	15	38	11.0 to 12.5	150	2	4	8	P629	80
6MBP25VBA120-50	1200	25	1.7	-	-	15	38	11.0 to 12.5	150	2	4	8	P626	100
6MBP35VBA120-50	1200	35	1.7	-	-	15	53	11.0 to 12.5	150	2	4	8	P626	100
6MBP50VBA120-50	1200	50	1.7	-	-	15	75	11.0 to 12.5	150	2	4	8	P626	100
6MBP25VFN120-50	1200	25	1.7	-	-	15	50	11.0 to 12.5	150	2	4	8	P636	190
6MBP35VFN120-50	1200	35	1.7	-	-	15	70	11.0 to 12.5	150	2	4	8	P636	190
6MBP50VFN120-50	1200	50	1.7	-	-	15	100	11.0 to 12.5	150	2	4	8	P636	190
7MBP25VFN120-50	1200	25	1.7	1200	15	15	50	11.0 to 12.5	150	2	4	8	P636	190
7MBP35VFN120-50	1200	35	1.7	1200	25	15	70	11.0 to 12.5	150	2	4	8	P636	190
7MBP50VFN120-50	1200	50	1.7	1200	25	15	100	11.0 to 12.5	150	2	4	8	P636	190

IGBT Module IPM < V series >

IPM (Intelligent Power Module) 600V, 1200V class

Built-in protection functions

- P-side fault status output (Alarm)
- N-side fault status output (Alarm)
- Under voltage protection (self shutdown)
- Over current protection (self shutdown)
- Overheating protection (self shutdown)

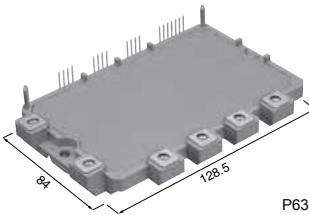
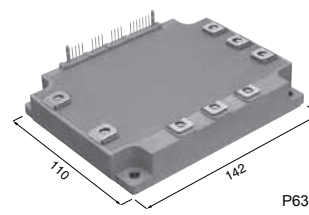
P630	600V		1200V		
	V series		V series		
	Without Brake-Chopper	With Brake-Chopper	Without Brake-Chopper	With Brake-Chopper	
	25A		6MBP25VDA120-50	7MBP25VDA120-50	
	35A		6MBP35VDA120-50	7MBP35VDA120-50	
	50A	6MBP50VDA060-50	7MBP50VDA060-50	6MBP50VDA120-50	7MBP50VDA120-50
			6MBP50VDN120-50	7MBP50VDN120-50	
	75A	6MBP75VDA060-50	7MBP75VDA060-50	6MBP75VDA120-50	7MBP75VDA120-50
			6MBP75VDN120-50	7MBP75VDN120-50	
	100A	6MBP100VDA060-50	7MBP100VDA060-50	6MBP100VDA120-50	7MBP100VDA120-50
		6MBP100VDN060-50	7MBP100VDN060-50	6MBP100VDN120-50	7MBP100VDN120-50
	150A	6MBP150VDA060-50	7MBP150VDA060-50		
		6MBP150VDN060-50	7MBP150VDN060-50		
	200A	6MBP200VDA060-50	7MBP200VDA060-50		
		6MBP200VDN060-50	7MBP200VDN060-50		
	100A		6MBP100VEA120-50	7MBP100VEA120-50	
	150A		6MBP150VEA120-50	7MBP150VEA120-50	
	200A	6MBP200VEA060-50	7MBP200VEA060-50	6MBP200VEA120-50	7MBP200VEA120-50
	300A	6MBP300VEA060-50	7MBP300VEA060-50		
	400A	6MBP400VEA060-50	7MBP400VEA060-50		

Dimension [mm]

Block Diagram

- 6MBP□VAA060-50
- 6MBP□VAA120-50

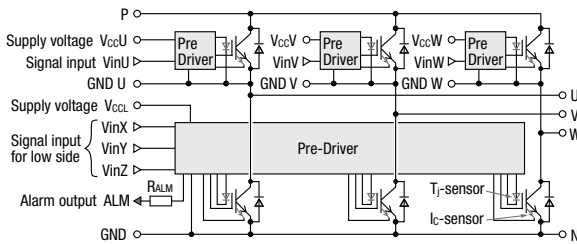

- 6MBP□VFN□-50
- 6MBP□VDA□-50
- 6MBP□VDN□-50
- 6MBP□VEA□-50

- 6MBP□VBA060-50
- 6MBP□VBA120-50

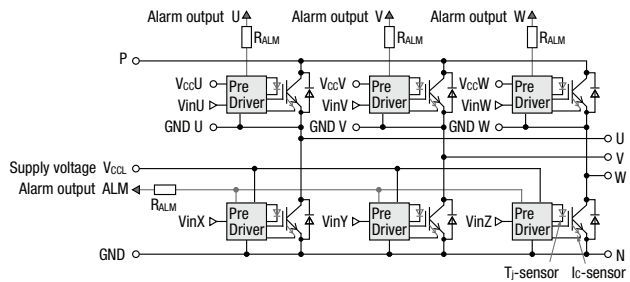

- 7MBP□VFN□-50
- 7MBP□VDA□-50
- 7MBP□VDN□-50
- 7MBP□VEA□-50

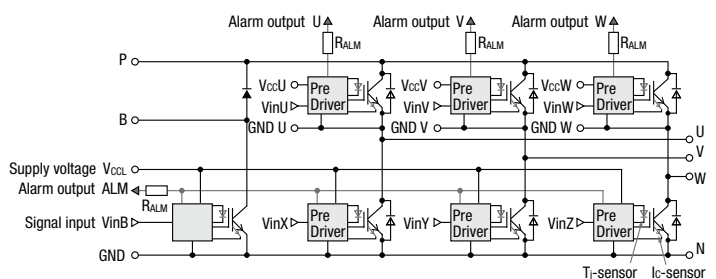
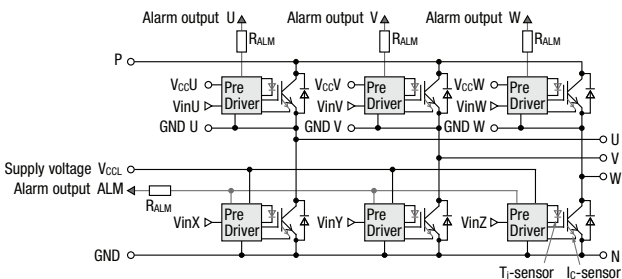





Device type	Inverter			Brake		Control							Package	Net mass
	V_{CES}	I_c	$V_{CE(sat)}$	V_{CES}	I_c	V_{CC}	$I_{oc}[INV]$	V_{UV}	T_{JOH}	Alarm signal hold time				
	Volts	Amps.	Volts	Volts	Amps.	Volts	Amps.	Volts	min. °C	OC typ. ms	UV typ. ms	T_{JOH} typ. ms	Grams	
6MBP50VDA060-50	600	50	1.4	-	-	15	75	11.0 to 12.5	150	2	4	8	P630	290
6MBP75VDA060-50	600	75	1.4	-	-	15	113	11.0 to 12.5	150	2	4	8	P630	290
6MBP100VDA060-50	600	100	1.4	-	-	15	150	11.0 to 12.5	150	2	4	8	P630	290
6MBP100VDN060-50	600	100	1.4	-	-	15	150	11.0 to 12.5	150	2	4	8	P630	290
6MBP150VDA060-50	600	150	1.4	-	-	15	225	11.0 to 12.5	150	2	4	8	P630	290
6MBP150VDN060-50	600	150	1.4	-	-	15	225	11.0 to 12.5	150	2	4	8	P630	290
6MBP200VDA060-50	600	200	1.4	-	-	15	300	11.0 to 12.5	150	2	4	8	P630	290
6MBP200VDN060-50	600	200	1.4	-	-	15	300	11.0 to 12.5	150	2	4	8	P630	290
7MBP50VDA060-50	600	50	1.4	600	30	15	75	11.0 to 12.5	150	2	4	8	P630	290
7MBP75VDA060-50	600	75	1.4	600	50	15	113	11.0 to 12.5	150	2	4	8	P630	290
7MBP100VDA060-50	600	100	1.4	600	50	15	150	11.0 to 12.5	150	2	4	8	P630	290
7MBP100VDN060-50	600	100	1.4	600	50	15	150	11.0 to 12.5	150	2	4	8	P630	290
7MBP150VDA060-50	600	150	1.4	600	75	15	225	11.0 to 12.5	150	2	4	8	P630	290
7MBP150VDN060-50	600	150	1.4	600	75	15	225	11.0 to 12.5	150	2	4	8	P630	290
7MBP200VDA060-50	600	200	1.4	600	100	15	300	11.0 to 12.5	150	2	4	8	P630	290
7MBP200VDN060-50	600	200	1.4	600	100	15	300	11.0 to 12.5	150	2	4	8	P630	290
6MBP200VEA060-50	600	200	1.25	-	-	15	300	11.0 to 12.5	150	2	4	8	P631	940
6MBP300VEA060-50	600	300	1.25	-	-	15	450	11.0 to 12.5	150	2	4	8	P631	940
6MBP400VEA060-50	600	400	1.25	-	-	15	600	11.0 to 12.5	150	2	4	8	P631	940
7MBP200VEA060-50	600	200	1.25	600	100	15	300	11.0 to 12.5	150	2	4	8	P631	940
7MBP300VEA060-50	600	300	1.25	600	150	15	450	11.0 to 12.5	150	2	4	8	P631	940
7MBP400VEA060-50	600	400	1.25	600	200	15	600	11.0 to 12.5	150	2	4	8	P631	940
6MBP25VDA120-50	1200	25	1.7	-	-	15	38	11.0 to 12.5	150	2	4	8	P630	290
6MBP35VDA120-50	1200	35	1.7	-	-	15	53	11.0 to 12.5	150	2	4	8	P630	290
6MBP50VDA120-50	1200	50	1.7	-	-	15	75	11.0 to 12.5	150	2	4	8	P630	290
6MBP50VDN120-50	1200	50	1.7	-	-	15	75	11.0 to 12.5	150	2	4	8	P630	290
6MBP75VDA120-50	1200	75	1.7	-	-	15	113	11.0 to 12.5	150	2	4	8	P630	290
6MBP75VDN120-50	1200	75	1.7	-	-	15	113	11.0 to 12.5	150	2	4	8	P630	290
6MBP100VDA120-50	1200	100	1.7	-	-	15	150	11.0 to 12.5	150	2	4	8	P630	290
6MBP100VDN120-50	1200	100	1.7	-	-	15	150	11.0 to 12.5	150	2	4	8	P630	290
7MBP25VDA120-50	1200	25	1.7	1200	15	15	38	11.0 to 12.5	150	2	4	8	P630	290
7MBP35VDA120-50	1200	35	1.7	1200	15	15	53	11.0 to 12.5	150	2	4	8	P630	290
7MBP50VDA120-50	1200	50	1.7	1200	25	15	75	11.0 to 12.5	150	2	4	8	P630	290
7MBP50VDN120-50	1200	50	1.7	1200	25	15	75	11.0 to 12.5	150	2	4	8	P630	290
7MBP75VDA120-50	1200	75	1.7	1200	35	15	113	11.0 to 12.5	150	2	4	8	P630	290
7MBP75VDN120-50	1200	75	1.7	1200	35	15	113	11.0 to 12.5	150	2	4	8	P630	290
7MBP100VDA120-50	1200	100	1.7	1200	50	15	150	11.0 to 12.5	150	2	4	8	P630	290
7MBP100VDN120-50	1200	100	1.7	1200	50	15	150	11.0 to 12.5	150	2	4	8	P630	290
6MBP100VEA120-50	1200	100	1.7	-	-	15	150	11.0 to 12.5	150	2	4	8	P631	940
6MBP150VEA120-50	1200	150	1.7	-	-	15	225	11.0 to 12.5	150	2	4	8	P631	940
6MBP200VEA120-50	1200	200	1.7	-	-	15	300	11.0 to 12.5	150	2	4	8	P631	940
7MBP100VEA120-50	1200	100	1.7	1200	50	15	150	11.0 to 12.5	150	2	4	8	P631	940
7MBP150VEA120-50	1200	150	1.7	1200	75	15	225	11.0 to 12.5	150	2	4	8	P631	940
7MBP200VEA120-50	1200	200	1.7	1200	100	15	300	11.0 to 12.5	150	2	4	8	P631	940

Note: The products with "VDN" on this page have high heat dissipation characteristics.

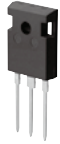
Discrete IGBT

Package	V _{CES} (V)	I _C (A)	Trench-FS							RB-IGBT			
			V series	High-Speed V series		High-Speed W series			XS series				
 TO-247-P2	600/650	30	FGW30N60VD						FGW30N65W		FGW30XS65		
		35		FGW35N60HD	FGW35N60H						FGW30XS65C		
				FGW35N60HC									
		40					FGW40N65WD		FGW40N65W			FGW40XS65	
							FGW40N65WE				FGW40XS65C		
		50		FGW50N60VD	FGW50N60HD	FGW50N60H	FGW50N65WD		FGW50N65W			FGW50XS65	
					FGW50N60HC		FGW50N65WE				FGW50XS65C		
		60					FGW60N65WD		FGW60N65W				
						FGW60N65WE							
	75			FGW75N60HD	FGW75N60H			FGW75N65W			FGW75XS65		
				FGW75N60HC		FGW75N65WE				FGW75XS65C			
	85											FGW85N60RB	
	1200	15		FGW15N120VD	FGW15N120HD	FGW15N120H							
		25		FGW25N120VD			FGW25N120WD		FGW25N120W				
						FGW25N120WE							
30				FGW30N120HD	FGW30N120H								
40			FGW40N120VD	FGW40N120HD	FGW40N120H	FGW40N120WD		FGW40N120W					
					FGW40N120WE								
 TO-247-4-P2	650	50					FGZ50N65WD						
							FGZ50N65WE						
	75						FGZ75N65WE						
	1200	40					FGZ40N120WE						

Recommended operating frequency

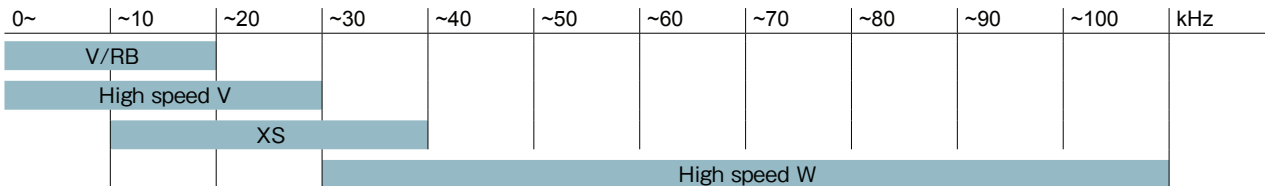

Part numbers

FGW30XS65C (example)

F	G	W		40	XS		65		C		
Company	Device code		Package code		Current	Series		Voltage		Diode Type	
Fuji	G	IGBT	W	TO-247-P2	×1	XS	XS series	65	650V	C	w/ Diode (Full rated)
										Blank	w/o Diode

FGW35N60HD (example)

F	G	W		40	N	65		W		D			
Company	Device code		Package code		Current	Polarity		Voltage		Diode Type			
Fuji	G	IGBT	W	TO-247-P2	×1	N	N-ch	60	600V	W	High Speed W series	C,E	w/ Diode (Full rated)
			Z	TO-247-4-P2				65	650V	H	High Speed V series		
								120	1200V	V	V series	D	w/ Diode
										RB	RB-IGBT	Blank	w/o Diode



Discrete IGBT XS series 650V class

Features

- IGBT in Trench-gate structure and Field-stop technology
- Low $V_{CE(sat)}$ and low switching Loss

IGBT in field-stop technology and trench-gate structure with Ultra fast FWD
650V class

Device type	Maximum Ratings				$V_{CE(sat)}$ ($V_{GE}=15V$) typ. Volts	E_{on} ($r_{g}=10\Omega$) typ. mJ	E_{off} mJ	Q_G typ. nC	V_F typ. Volts	I_F $T_c=100^\circ C$		Q_{rr} typ. μC	Package	Net mass Grams
	V_{CES}	I_C	I_{CP}	P_D						Amps.	Amps.			
	Volts	Amps.	Amps.	Watts										
○ FGW30XS65	650	30	120	174	(1.35)	0.23	0.33	123	-	-	-	TO-247-P2	6.0	
○ FGW30XS65C	650	30	120	174	(1.35)	0.23	0.33	123	(1.78)	30	(0.9)	TO-247-P2	6.0	
○ FGW40XS65	650	40	160	234	(1.35)	0.30	0.44	164	-	-	-	TO-247-P2	6.0	
○ FGW40XS65C	650	40	160	234	(1.35)	0.30	0.44	164	(1.78)	40	(1.2)	TO-247-P2	6.0	
○ FGW50XS65	650	50	200	290	(1.35)	0.38	0.55	205	-	-	-	TO-247-P2	6.0	
○ FGW50XS65C	650	50	200	290	(1.35)	0.38	0.55	205	(1.78)	50	(1.5)	TO-247-P2	6.0	
○ FGW75XS65	650	75	300	437	(1.35)	0.57	0.83	308	-	-	-	TO-247-P2	6.0	
○ FGW75XS65C	650	75	300	437	(1.35)	0.57	0.83	308	(1.78)	75	(2.3)	TO-247-P2	6.0	

○ : Under development

Discrete IGBT High Speed W series 650V,1200V class

Features

- IGBT in Trench-gate structure and Field-stop technology
- Low $V_{CE(sat)}$ and low switching Loss
- High switching frequency (to 100kHz)

IGBT in field-stop technology and trench-gate structure with Ultra fast FWD
650V,1200V class

Device type	Maximum Ratings				$V_{CE(sat)}$ ($V_{GE}=15V$) typ. Volts	E_{on} ($r_{g}=10\Omega$) typ. mJ	E_{off} mJ	Q_G typ. nC	V_F typ. Volts	I_F $T_c=100^\circ C$		Q_{rr} typ. μC	Package	Net mass Grams
	V_{CES}	I_C	I_{CP}	P_D						Amps.	Amps.			
	Volts	Amps.	Amps.	Watts										
● FGW30N65W	650	30	120	180	1.8	0.12	0.15	128	-	-	-	TO-247-P2	6.0	
● FGW40N65W	650	40	160	260	1.8	0.29	0.29	180	-	-	-	TO-247-P2	6.0	
● FGW40N65WD	650	40	160	260	1.8	0.29	0.29	180	2.5	20	0.26	TO-247-P2	6.0	
● FGW40N65WE	650	40	160	260	1.8	0.29	0.29	180	2.5	40	0.29	TO-247-P2	6.0	
● FGW50N65W	650	50	200	330	1.8	0.42	0.46	215	-	-	-	TO-247-P2	6.0	
● FGW50N65WD	650	50	200	330	1.8	0.42	0.46	215	2.5	25	0.32	TO-247-P2	6.0	
● FGW50N65WE	650	50	200	330	1.8	0.42	0.46	215	2.5	50	0.35	TO-247-P2	6.0	
● FGZ50N65WD	650	50	200	330	1.8	0.12	0.40	215	2.5	25	0.32	TO-247-4-P2	6.0	
● FGZ50N65WE	650	50	200	330	1.8	0.12	0.40	215	2.5	50	0.35	TO-247-4-P2	6.0	
● FGW60N65W	650	60	240	405	1.8	0.6	0.67	250	-	-	-	TO-247-P2	6.0	
● FGW60N65WD	650	60	240	405	1.8	0.6	0.67	250	2.5	30	0.3	TO-247-P2	6.0	
● FGW60N65WE	650	60	240	405	1.8	0.6	0.67	250	2.5	60	0.33	TO-247-P2	6.0	
● FGW75N65W	650	75	300	520	1.8	0.95	1.2	300	-	-	-	TO-247-P2	6.0	
● FGW75N65WE	650	75	300	520	1.8	0.95	1.2	300	2.5	75	0.41	TO-247-P2	6.0	
● FGZ75N65WE	650	75	300	520	1.8	0.37	0.68	300	2.5	75	0.41	TO-247-4-P2	6.0	
● FGW25N120W	1200	25	100	270	2.0	0.9	1.3	80	-	-	-	TO-247-P2	6.0	
● FGW25N120WD	1200	25	100	270	2.0	0.9	1.3	80	2.2	12	0.6	TO-247-P2	6.0	
● FGW25N120WE	1200	25	100	270	2.0	0.9	1.3	80	2.2	25	0.6	TO-247-P2	6.0	
● FGW40N120W	1200	40	160	430	2.0	2.8	1.6	120	-	-	-	TO-247-P2	6.0	
● FGW40N120WD	1200	40	160	430	2.0	2.8	1.6	120	2.2	20	0.95	TO-247-P2	6.0	
● FGW40N120WE	1200	40	160	430	2.0	2.8	1.6	120	2.4	40	2.2	TO-247-P2	6.0	
● FGZ40N120WE	1200	40	160	430	2.0	1.1	1.4	120	2.4	40	2.2	TO-247-4-P2	6.0	

● : New products

Discrete IGBT V/High Speed V series 600V, 1200V class

Features

- IGBT in Trench-gate structure and Field-stop technology
- Low $V_{CE(sat)}$ and low switching Loss
(High Speed V series)
- Short circuit withstand time; $t_{sc}=10\mu s$ (V series)

IGBT in field-stop technology and trench-gate structure with Ultra fast FWD
600V class

Device type	Maximum Ratings				$V_{CE(sat)}$ ($V_{GE}=15V$) typ. Volts	E_{on} ($r_g=10\Omega$) typ. mJ	E_{off} mJ	Q_G typ. nC	V_F		Q_{rr} typ. μC	Package	Net mass Grams
	V_{CES}	I_C $T_c=100^\circ C$	I_{CP}	P_D IGBT					typ. Volts	I_F Amps.			
	Volts	Amps.	Amps.	Watts									
FGW30N60VD	600	30	60	230	1.6	1.2	0.7	225	1.5	25	0.7	TO-247-P2	6.0
FGW35N60H	600	35	105	230	1.5	0.9	0.85	210	-	-	-	TO-247-P2	6.0
FGW35N60HD	600	35	105	230	1.5	0.9	0.85	210	2.0	15	0.06	TO-247-P2	6.0
FGW35N60HC	600	35	105	230	1.5	0.95	0.85	210	2.35	35	0.13	TO-247-P2	6.0
FGW50N60H	600	50	150	360	1.5	1.4	1.7	305	-	-	-	TO-247-P2	6.0
FGW50N60HD	600	50	150	360	1.5	1.4	1.7	305	2.0	25	0.08	TO-247-P2	6.0
FGW50N60HC	600	50	150	360	1.5	1.5	1.7	305	2.3	50	0.07	TO-247-P2	6.0
FGW50N60VD	600	50	100	360	1.6	2.4	1.4	360	1.5	35	0.75	TO-247-P2	6.0
FGW75N60H	600	75	225	500	1.5	3.0	4.2	460	-	-	0.12	TO-247-P2	6.0
FGW75N60HD	600	75	225	500	1.5	3.0	4.2	460	2.0	35	0.13	TO-247-P2	6.0
FGW75N60HC	600	75	225	500	1.5	3.8	4.2	460	2.3	75	0.3	TO-247-P2	6.0

1200V class

Device type	Maximum Ratings				$V_{CE(sat)}$ ($V_{GE}=15V$) typ. Volts	E_{on} ($r_g=10\Omega$) typ. mJ	E_{off} mJ	Q_G typ. nC	V_F		Q_{rr} typ. μC	Package	Net mass Grams
	V_{CES}	I_C $T_c=100^\circ C$	I_{CP}	P_D IGBT					typ. Volts	I_F Amps.			
	Volts	Amps.	Amps.	Watts									
FGW15N120H	1200	15	45	155	1.8	0.6	0.8	140	-	-	-	TO-247-P2	6.0
FGW15N120HD	1200	15	45	155	1.8	0.6	0.8	140	2.2	12	0.6	TO-247-P2	6.0
FGW15N120VD	1200	15	30	155	1.85	1.1	0.8	150	1.7	15	0.85	TO-247-P2	6.0
FGW25N120VD	1200	25	50	260	1.85	2.2	1.4	235	1.7	25	1.2	TO-247-P2	6.0
FGW30N120H	1200	30	90	260	1.8	1.6	1.5	230	-	-	-	TO-247-P2	6.0
FGW30N120HD	1200	30	90	260	1.8	1.6	1.5	230	2.2	20	0.95	TO-247-P2	6.0
FGW40N120H	1200	40	120	340	1.8	2.8	1.8	300	-	-	-	TO-247-P2	6.0
FGW40N120HD	1200	40	120	340	1.8	2.8	1.8	300	2.2	30	1.35	TO-247-P2	6.0
FGW40N120VD	1200	40	80	340	1.85	4.3	2.2	320	1.7	30	1.45	TO-247-P2	6.0

Discrete RB-IGBT

Features

- Reverse blocking character is realized for 1 chip by Fuji's original technology.
- High efficiency by applying to T-type 3 level inverter circuit.

Characteristics

Device type	Maximum Ratings					$V_{CE(sat)}$ ($V_{GE}=15V$) typ. Volts	E_{on} ($r_g=10\Omega$) typ. mJ	E_{off} mJ	Q_G typ. nC	t_{rr} typ. n sec	Package	Net mass Grams
	V_{CES}	I_C $T_c=100^\circ C$	I_{CP}	t_{sc}	P_D IGBT							
	Volts	Amps.	Amps.	$\mu sec.$	Watts							
FGW85N60RB	600	85	170	10	600	2.45	4.7	2.4	300	165	TO-247-P2	6.0



IGBT Module for Electric Vehicle and Hybrid Electric Vehicle

IGBT IPM for Electric Vehicle and Hybrid Electric Vehicle

Features

- Including circuit board which has IGBT drive and protection function
- Optical isolated
(signal input, IGBT's temperature monitor, alarm output)
- Detection and protection
(short-circuit, over-temperature, under-voltage)
- Lead Free Package

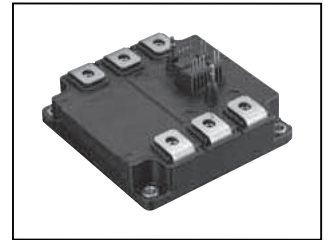

Characteristics

($T_{vj}=25^{\circ}\text{C}$)

Device type	V_{CES} Volts	$I_{C(Cont)}$ Amps.	$V_{CE(sat)}$ typ. Volts	V_F typ. Volts	Package	Net mass Grams
2MBP600UN120V	1200	600	2.00	2.20	P401	680

IGBT Module for Electric Vehicle and Hybrid Electric Vehicle

Features

- 7th Generation "RC-IGBT" 750V-IGBT
- Direct liquid Cooling AL Water jacket
- High power density, small and light weight package
- High reliability : T_{vjmax} 175°C guaranteed
- RoHS compliant

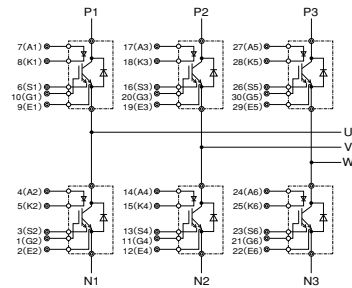

Characteristics

$V_{CE(sat)}$: at $T_{vj}=25^{\circ}\text{C}$, Chip

Device type	V_{CES} Volts	$I_{C(Cont)}$ Amps.	$I_{C(Peak)}$ Amps.	$V_{CE(sat)}$ typ. Volts	V_F typ. Volts	Package	Net mass Grams
6MBI800XV-075V-01	750	570	1600	1.45 ($I_C=800A$)	1.50 ($I_F=800A$)	M653	560

2 SiC Devices

SiC Devices



SiC devices have excellent characteristics that realize high blocking voltage, low power dissipation, high-frequency operation and high-temperature operation.

Power semiconductors that make use of SiC achieve significant reduction in energy consumption, and can be used to develop smaller and lighter products.

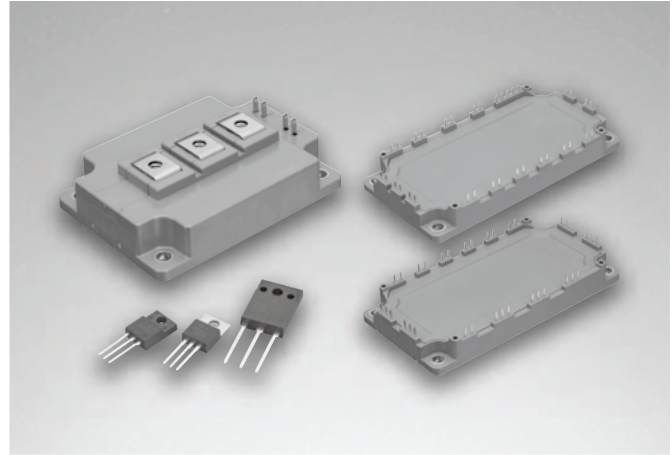

IGBT Hybrid Modules with SiC-SBD X series / V series



■ Features

- High performance chips
- X series / V series IGBT for low loss operation
- SiC-SBD for low loss operation
- The same package lineup as the conventional Si-IGBT modules

■ Part numbers

2MSI300VAH-120C-53 (example)

2	MS	I	300	V	A	H	120	C	53
Number of IGBT Switches	Chip : Si-IGBT+SiC-SBD	Internal Configuration	Rated Current	IGBT Device Technology	SBD Dvice	Package Type	Max V_{CE}	SiC-SBD for converter	RoHS Compliant
	MS Si-IGBT+SiC-SBD	I: Standard Modules	× 1	V: V series (6th Generation)	A: 1st gen.		060: 600V	C: Large current	None, 01 to 49 Non RoHS Compliant
	S SiC-SBD	R: Power Integrated Modules		X: X series (7th Generation)			120: 1200V		50 to 99 RoHS Compliant
							170: 1700V		
							330: 3300V		

■ PIM/Built-in converter and brake EconoPIM™ 600, 1200V class

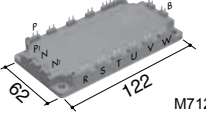
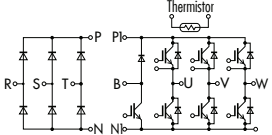
 M712		I_C	600V	1200V
			IGBT Hybrid Modules with SiC-SBD V series	
		35A		7MSR35VAB120-50
		50A	7MSR50VAB060-50	7MSR50VAB120-50
		75A	7MSR75VAB060-50	
		100A	7MSR100VAB060-50	

Dimension [mm]

Device type	Inverter [IGBT]				Brake [IGBT+FED]			Converter [Diode]				Package	Net mass Grams
	V_{CES}	I_C Cont.	P_C Watts	$V_{CE(sat)}$ typ. Volts	V_{CES}	I_C Cont. Amps.	V_{RRM} Volts	V_{RRM}	I_O Cont. Amps.	V_{FM} typ. Volts	I_{FSM} Amps.		
	Volts	Amps.	Watts	Volts	Volts	Amps.	Volts	Volts	Amps.	Volts	Amps.		
● 7MSR50VAB060-50	600	50	215	1.6	600	50	600	800	50	1.3	210	M712	330
● 7MSR75VAB060-50	600	75	300	1.6	600	50	600	800	75	1.25	500	M712	330
● 7MSR100VAB060-50	600	100	335	1.6	600	50	600	800	100	1.25	700	M712	330
● 7MSR35VAB120-50	1200	35	210	1.85	1200	25	1200	1600	35	1.35	260	M712	330
● 7MSR50VAB120-50	1200	50	280	1.85	1200	35	1200	1600	50	1.35	360	M712	330

● : New Products

Note: EconoPIM™ is registered trademarks of Infineon Technologies AG, Germany.

■ 6-pack EconoPACK™ 1200V class

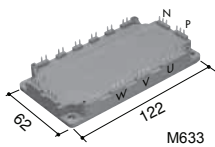
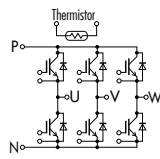
 M633		I_C	1200V	
			IGBT Hybrid Modules with SiC-SBD V series	
		100A	6MSI100VAB-120-50	

Dimension [mm]

Device type	V_{CES}	V_{GES}	I_C Cont.	P_C Watts	$V_{CE(sat)}$ ($V_{GE}=15V$)		Switching time			Package	Net mass Grams
	Volts	Volts	Amps.	Watts	Volts	I_C Amps.	t_{on} typ. μ sec.	t_{off} typ. μ sec.	t_f typ. μ sec.		
	Volts	Volts	Amps.	Watts	Volts	Amps.	μ sec.	μ sec.	μ sec.		
● 6MSI100VAB-120-50	1200	± 20	100	520	1.75	100	0.39	0.42	0.05	M633	300

● : New Products

Note: EconoPIM™ is registered trademarks of Infineon Technologies AG, Germany.

Standard 2-pack 1200, 1700V class

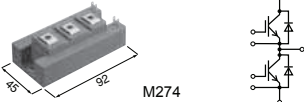
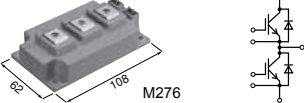
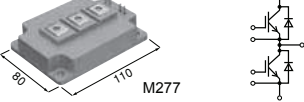
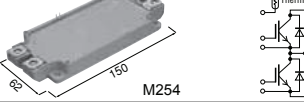
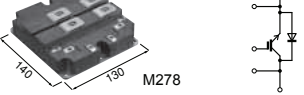
 M274	I_c	1200V	1700V
		IGBT Hybrid Modules with SiC-SBD V series	
 M276	200A	2MSI200VAB-120-53	
	300A	2MSI300VAH-120C-53	
 M277	400A		2MSI400VAE-170-53
 M254	300A	2MSI300VAN-120-53	
	450A	2MSI450VAN-120-53	
	550A		2MSI550VAN-170-53
	600A	2MSI600VAN-120-53	
 M278	1200A		2MSI1200VAT-170PC 2MSI1200VAT-170EC

Dimension [mm]

Device type	V_{CES} Volts	V_{GES} Volts	I_c Cont. Amps.	P_C Watts	$V_{CE(sat)}$ ($V_{GE}=15V$) typ.		Switching time			Package	Net mass Grams
					Volts	I_c Amps.	t_{on} typ. μ sec.	t_{off} typ. μ sec.	t_f typ. μ sec.		
● 2MSI200VAB-120-53	1200	± 20	200	1500	1.75	200	0.64	0.70	0.07	M274	270
● 2MSI300VAH-120C-53	1200	± 20	300	1600	1.75	300	0.82	0.84	0.09	M276	370
● 2MSI300VAN-120-53	1200	± 20	300	1595	1.75	300	0.49	0.72	0.12	M254	300
● 2MSI450VAN-120-53	1200	± 20	450	2270	1.75	450	0.36	0.72	0.07	M254	300
○ 2MSI600VAN-120-53	1200	± 20	600	3750	1.85	600	0.55	1.05	0.11	M254	300
○ 2MSI550VAN-170-53	1700	± 20	550	3750	2.15	550	0.69	1.18	0.10	M254	300
● 2MSI400VAE-170-53	1700	± 20	400	4540	2.00	400	1.05	1.95	0.09	M277	470
○ 2MSI1200VAT-170PC	1700	± 20	1200	7040	1.80	1200	2.63	2.60	0.50	M278	900
○ 2MSI1200VAT-170EC	1700	± 20	1200	7040	2.00	1200	1.77	1.59	0.16	M278	900

● : New Products ○ : Under development

Standard 1-pack 3300V class

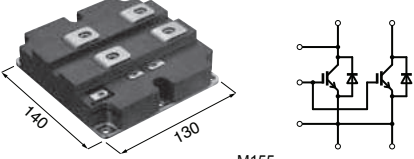
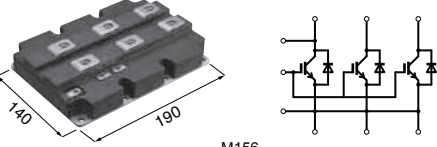
 M155		3300V	
		IGBT Hybrid Modules with SiC-SBD X series	
1200A	1MSI1200XAGF330-03		
 M156		3300V	
		IGBT Hybrid Modules with SiC-SBD X series	
1800A	1MSI1800XAEF330-03		

Dimension [mm]

Device type	V_{CES} Volts	V_{GES} Volts	I_C Cont. Amps.	P_{tot} Watts	$V_{CE(sat)}$ ($V_{GE}=15V$)		Switching time			Package	Net mass Grams
					typ. Volts	I_C Amps.	$t_{d(on)}$ typ. μsec.	$t_{d(off)}$ typ. μsec.	t_f typ. μsec.		
● 1MSI1200XAGF330-03	3300	±20	1200	12500	2	1200	1.6	1.65	1.25	M155	900
● 1MSI1800XAEF330-03	3300	±20	1800	18650	2	1800	1.6	1.8	1.3	M156	1300

● : New Products

2 SiC Devices

Standard 2-pack 3300V class

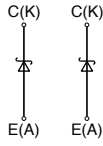
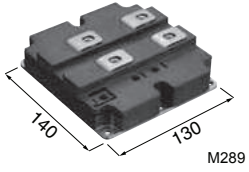

I_C	3300V
	SiC-SBD series
900A	2SI900AGF330-03

Dimension [mm]

Device type	V_{CES} Volts	V_{GES} Volts	I_C Cont. Amps.	P_{tot} Watts	$V_{CE(sat)}$ ($V_{GE}=15V$)		Switching time			Package	Net mass Grams
					typ. Volts	I_C Amps.	$t_{d(on)}$ typ. $\mu sec.$	$t_{d(off)}$ typ. $\mu sec.$	t_f typ. $\mu sec.$		
● 2SI900AGF330-03	3300	-	900	-	2.05	900	-	-	-	M289	900

● : New Products

SiC Schottky-Barrier Diodes (SBD)



■ Features

- High speed switching
- High-frequency operation, miniaturization, weight saving
- Low- V_f
- Low- I_R
- $T_{vj}=175^{\circ}\text{C}$ Guaranteed, High-temperature operation, Low-Loss, High efficiency
- High avalanche capability

■ Part numbers

FDCC10S65A(example)

F	DC		P		10	S		65		A	
Company code	Device code		Package code		Current	Polarity		Voltage		Application	
Fuji	DC	SiCSBD	A	TO-220F	x 1	S, T	Single	65	650V	A	For Automotive
			C	T-Pack(S)		C	Cathode Common	120	1200V		
			P	TO-220							
			Y	TO-247							
			W	TO-247-2-P2							





■ SiC-SBD Series

SiC-SBD Series			TO-220-2	TO-220	TO-220F-2	TO-220F	TO-247-2-P2	TO-247	T-Pack(S)
Chip	V_{RRM} (V)	I_F (A)							
Single	650	10	✓		✓			✓	✓
		25	✓		✓			✓	✓
	1200	18			✓		✓	✓	
Dual	650	20		✓		✓		✓	✓
		50						✓	
		36						✓	

Device type	Maximum rating			Thermal rating	Characteristics ($T_a=25^{\circ}\text{C}$)		Package	Net mass Grams
	V_{RRM} Volts	I_F Amps.	I_{FSM}^{*1} Amps.		T_{vj} max.($^{\circ}\text{C}$)	V_F max. Volts		
FDCC10S65	650	10	50	175	1.8	10	TO-220-2	2.0
FDCC20C65	650	20	50	175	1.8	10	TO-220	2.0
FDCC25S65	650	25	100	175	1.6	10	TO-220-2	2.0
FDCA10S65	650	10	50	175	1.8	10	TO-220F-2	1.7
FDCA20C65	650	20	50	175	1.8	10	TO-220F	1.7
FDCA25S65	650	25	100	175	1.6	10	TO-220F-2	1.7
FDCY10S65	650	10	50	175	1.8	10	TO-247	6.4
FDCY20C65	650	20	50	175	1.8	10	TO-247	6.4
FDCY25S65	650	25	100	175	1.6	10	TO-247	6.4
FDCY50C65	650	50	100	175	1.6	10	TO-247	6.4
FDCC10S65	650	10	50	175	1.8	10	T-Pack(S)	1.6
FDCC20C65	650	20	50	175	1.8	10	T-Pack(S)	1.6
FDCC25S65	650	25	100	175	1.6	10	T-Pack(S)	1.6
FDCA18S120	1200	18	90	175	1.7	10	TO-220F-2	1.7
FDCY18S120	1200	18	90	175	1.7	10	TO-247	6.4
FDCW18T120	1200	18	90	175	1.7	10	TO-247-2-P2	6.0
FDCY36C120	1200	36	90	175	1.7	10	TO-247	6.4

*1: Half sine wave $t_p=10\text{ms}$ *2: $V_R=V_{RRM}$

Automotive SiC Schottky-Barrier Diodes

SiC-SBD Series			TO-220-2	TO-220	TO-247	T-Pack(S)
						
Chip	V_{RRM} (V)	I_F (A)				
Single	650	10	✓		✓	✓
		25	✓		✓	✓
	1200	18			✓	
Dual	650	20		✓	✓	✓
		50			✓	
	1200	36			✓	

Device type	Maximum rating			Thermal rating	Characteristics ($T_a=25^\circ\text{C}$)		Package	Net mass Grams
	V_{RRM} Volts	I_F Amps.	I_{FSM}^{*1} Amps.	T_{vj} and T_{stg} $^\circ\text{C}$	V_F max. Volts	I_{RRM}^{*2} max. μA		
FDCP10S65A	650	10	50	-55 to +175	1.8	5	TO-220-2	2.0
FDCY10S65A	650	10	50	-55 to +175	1.8	5	TO-247	6.4
FDCC10S65A	650	10	50	-55 to +175	1.8	5	T-Pack(S)	1.6
FDCP20C65A	650	20	100	-55 to +175	1.8	5	TO-220	2.0
FDCY20C65A	650	20	100	-55 to +175	1.8	5	TO-247	6.4
FDCC20C65A	650	20	100	-55 to +175	1.8	5	T-pack(S)	1.6
FDCP25S65A	650	25	100	-55 to +175	1.7	10	TO-220-2	2.0
FDCY25S65A	650	25	100	-55 to +175	1.7	10	TO-247	6.4
FDCC25S65A	650	25	100	-55 to +175	1.7	10	T-pack(S)	1.6
FDCY50C65A	650	50	200	-55 to +175	1.7	10	TO-247	6.4
FDCY18S120A	1200	18	90	-55 to +175	1.8	10	TO-247	6.4
FDCY36C120A	1200	36	180	-55 to +175	1.8	10	TO-247	6.4

*1: Half sine wave $t_p=10\text{ms}$

*2: $V_R=V_{RRM}$

Integrated Circuits



Fuji Electric offers a lineup of AC/DC and DC/DC power supply control ICs that support a variety of power circuits. These highly efficient, low-noise products with low standby power consumption are compatible with environmental regulations. Furthermore, many protection functions are built into the ICs themselves, allowing for smaller power circuits.

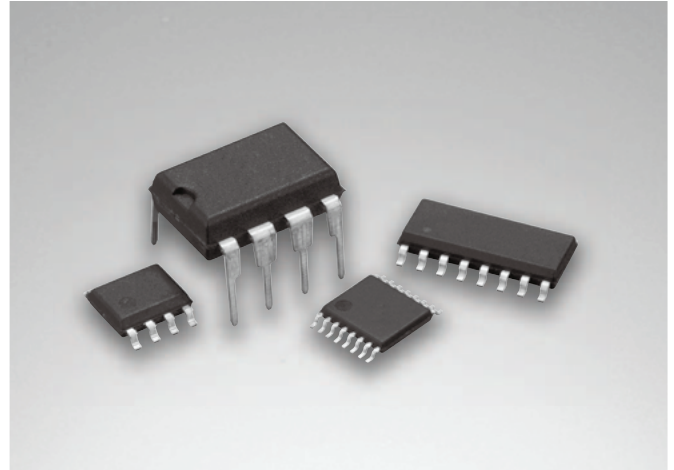

Features of Power Supply control ICs

Green Mode PWM-ICs

■ Features

- Built-in 500/650V withstand voltage start up circuit
- Green mode functions (Intermittent Switching/Linerary reduced switching frequency)
- Protect functions (Over voltage/Brown out/2 stage Over power)
- Low EMI noise

Green Mode Quasi-resonant ICs

■ Features

- Built-in 500V withstand voltage start up circuit
- Green mode functions (Intermittent Switching/Linerary reduced switching frequency)
- Protect functions (Over voltage/Over load etc.)

Power Factor Correction ICs

■ Features

- Wide electric power range(From 75W to 1kW)
- Power factor ≥ 0.99
- Protect functions (FB Pin open short/Over voltage etc.)

Current Resonant ICs

■ Features

- Realize 1 convertor circuit structure at world wide input power
- Built-in High side driver
- Preventing capacitive region operation
- Protect functions
(Over current/Over voltage/Over load/Over heat/Brown out)
- Green mode function (Intermittent switching)

High and Low side driver IC

■ Features

- High negative transient voltage on VS terminal
- Wide range supply voltage up to 30V (FA5650/5651)
- 3.3V logic compatible
- Built-in under voltage lockout
- Allowable offset supply voltage transient dVs/dt up to 50kV/us
- High speed response: Turn on/off delay time 125ns (Typ)
(FA5650/5651)

Part numbers

FA8A00N (example)

F		A		8		A		00		N	
Company Symbol		Control System		Series		Generation		Number		Package code	
F	Fuji	A	Analog	1	CRMPFC	A	1G	Two-digit integer	N	SOP	
				6	LLC	B	2G		P	DIP	
				8	PWM	C	3G				
							

FA5590N (example)

F		A		55		90		N	
Company Symbol		Control System		Series		Number		Package code	
F	Fuji	A	Analog	3X	AC/DC	Two-digit integer	M/N/S	SOP	
				5X	AC/DC		P	DIP	
				7X	DC/DC		V	TSSOP	
				13X	AC/DC				

AC/DC Power Supply control ICs

● Green mode PWM-ICs (Current mode)

Type Name	Duty	Input voltage	Frequency		Current sense	Over load protection	Over power protection	Over voltage protection	Built-in start up circuit	Green mode function	X-Cap discharge function	
			65kHz	100kHz								
With Brown out function												
FA8A00N	83%	12 - 24V	✓		Positive	Auto-Recovery	2Stage (OPP ratio 1:1.4)	Latch	500V	Lineary frequency reduction Intermittent opration	✓	
FA8A40N				✓		Timer-latch						
FA8A01N			✓									
FA8A41N				✓								
FA8B16N●			✓			Auto-Recovery	2Stage (OPP ratio 1:1.5)					
FA8A27N		10 - 28V	✓			Timer-latch	2Stage (OPP ratio 1:1.8)					
FA8A37N												
FA8A39N												
Without Brown out function												
FA5680N	85%	11 - 24V	✓		Negative	Auto-Recovery	1Stage	Latch	500V	Lineary frequency reduction Intermittent opration	✓	
FA5681N			✓			Timer-latch						
FA8A60N	83%	10 - 24V	✓		Positive	Auto-Recovery	1Stage	Latch	650V	Lineary frequency reduction Intermittent opration	✓	
FA8A64N				✓		Timer-latch						
FA8A61N			✓									
FA8A65N				✓								
FA8A70N			✓			Auto-Recovery						
FA8A74N				✓								
FA8A71N			✓			Timer-latch						
FA8A75N				✓								
FA8A12N				✓			Auto-Recovery					2Stage
FA8A80N				✓			Auto-Recovery					1Stage
FA8A84N		✓		Timer-latch								
FA8A81N		✓			1Stage							
FA8A85N		✓		Auto-Recovery								
FA8A90N		✓			1Stage							
FA8A94N		✓	✓	Timer-latch								
FA8A91N		✓										
FA8A95N			✓								✓	

PKG : SOP-8

● : New Products

IC

● Green mode PWM-ICs with Brown Out function

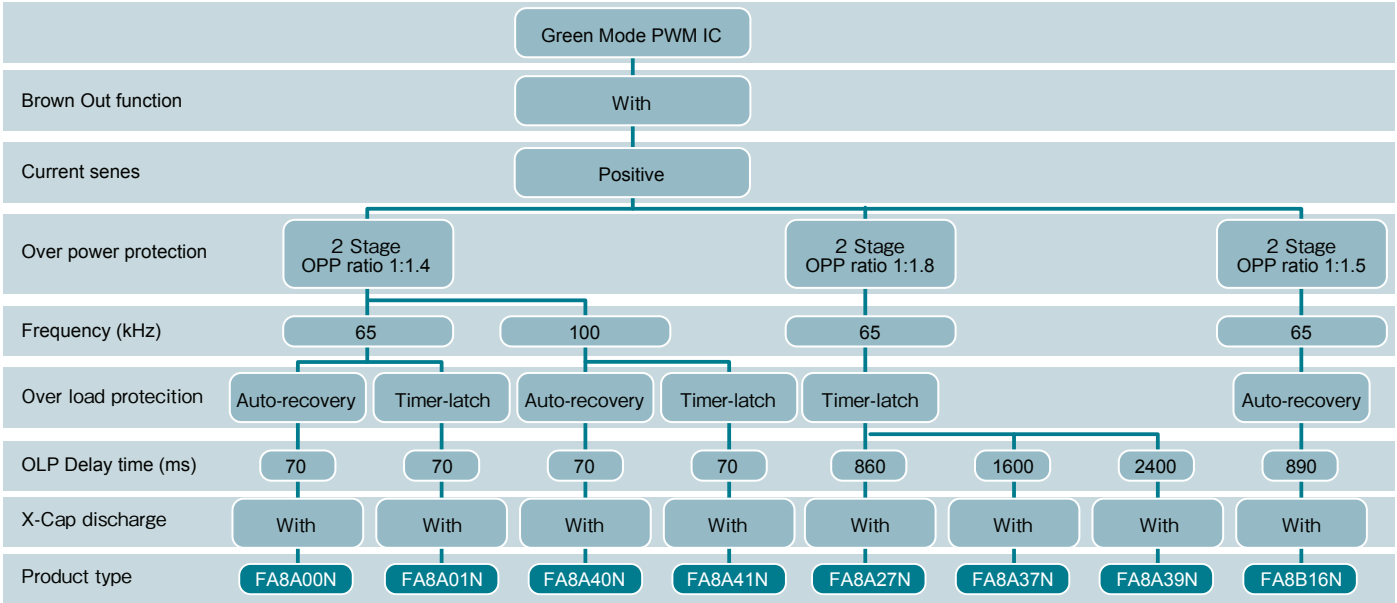

● Green mode PWM-ICs without Brown Out function

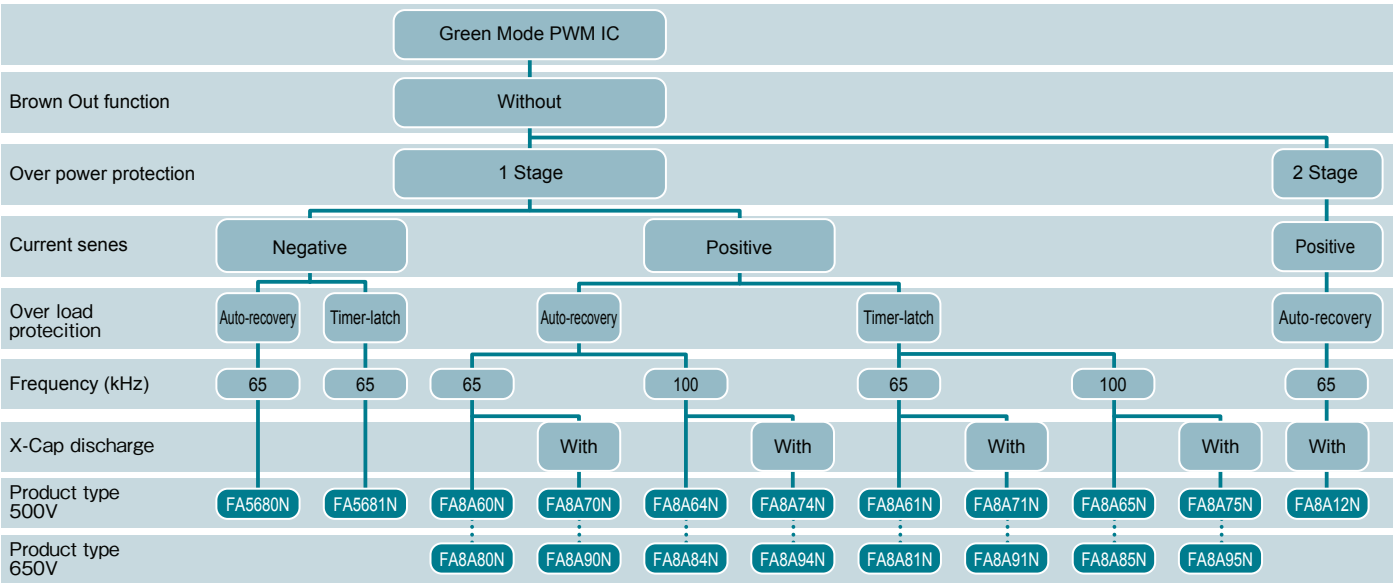

● Block diagram (Main model)

FA8A00N (With Brown out)

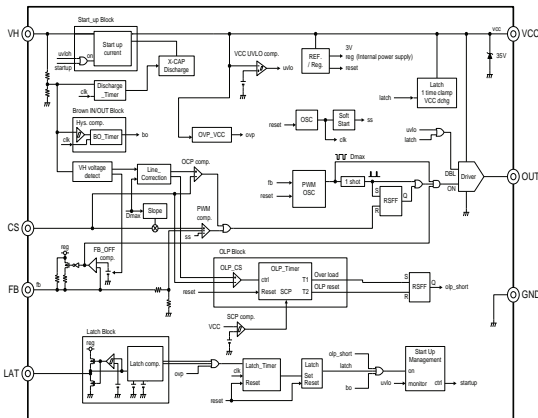

FA8A61N (Without Brown out)

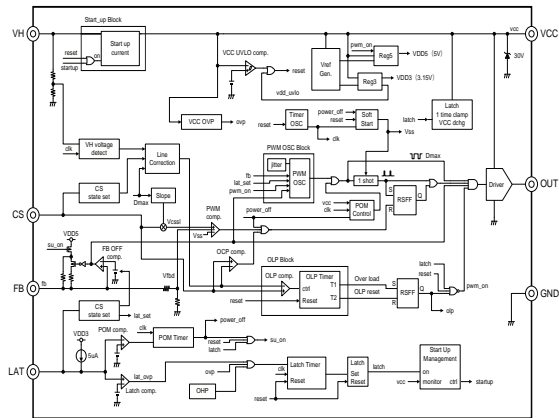

● General PWM-ICs

Type Name	Control mode	Duty	Input voltage	Current sense	Over load protection	Over voltage protection	Under-voltage lockout (ON/OFF)	Remarks
With Green mode function								
FA3641P/N	Voltage mode	70%	10 - 28V	Positive	Timer-latch	Latch	16.5V/9.0V	
FA3647P/N				Negative				
FA5604N		46%	10 - 30V	Negative	Auto-Recovery		17.5V/9.7V	Frequency reduction start/stop FB voltage under light load 1.8V/1.95V
FA5605N		70%						
FA5606N								
Without Green mode function								
FA13842P/N	Current mode	96%	10 - 25V	Positive	-	-	16.5V/9.0V	
FA13843P/N							9.6V/9.0V	
FA13844P/N		48%					16.5V/9.0V	
FA13845P/N							9.6V/9.0V	
FA5504P/N	Voltage mode	46%	10 - 28V	Positive	Timer-latch	Latch	16.5V/9.0V	With error amplifier
FA5510P/N								
FA5511P/N		70%						
FA5514P/N		46%						
FA5515P/N		70%	Negative	Auto-Recovery	17.5V/9.7V			
FA5607N								

PKG: "P":DIP-8, "N":SOP-8
 Frequency: Adjustable

● General PWM-ICs

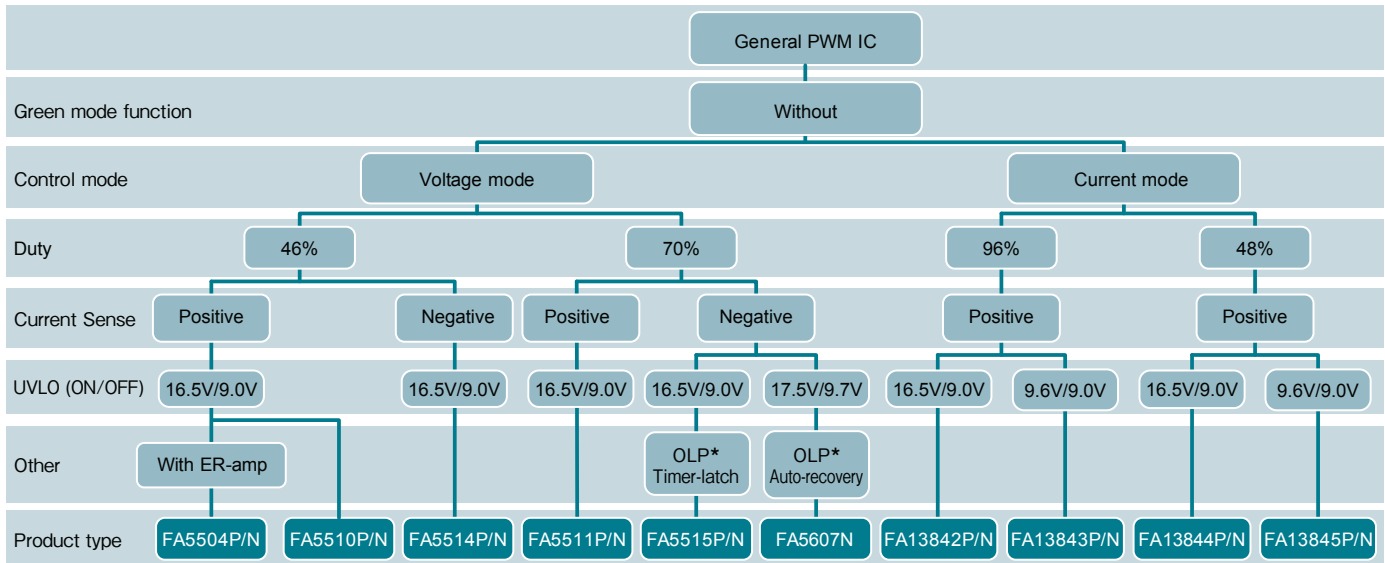
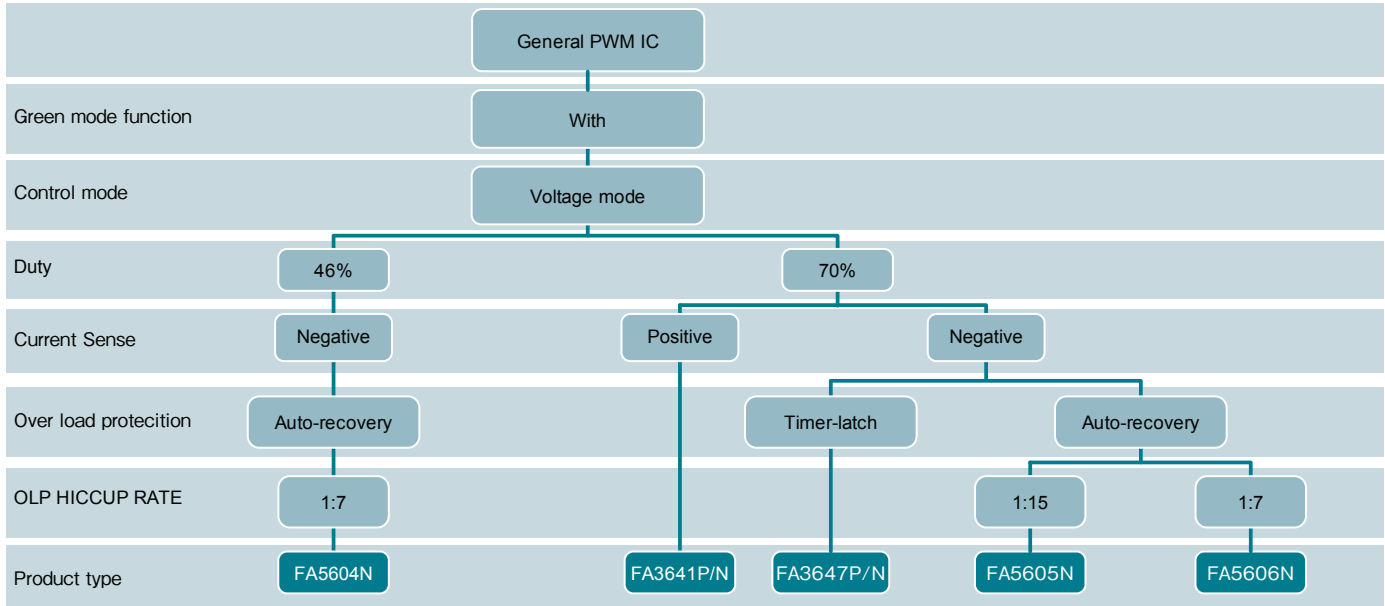

*OLP : Over Load Protection

● Block diagram (Main model)

FA13842P/N

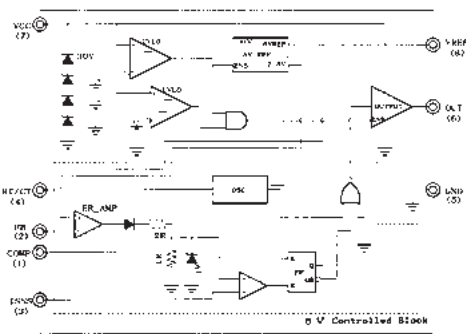

FA5604N

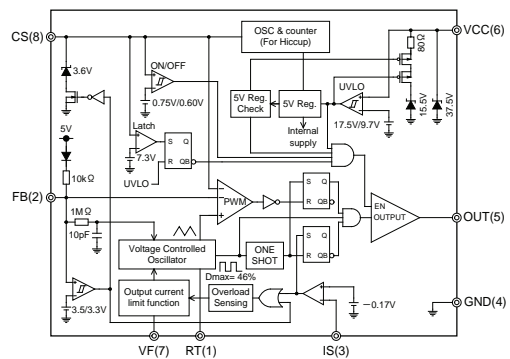

● Green mode Quasi-resonant ICs (Current mode)

Type Name	Input voltage	Maximum frequency	Over load protection	Over voltage sense	Built-in start up circuit	Green mode function	Under-voltage lockout (ON/OFF)	Remarks	
FA5570N	10 - 28V	120kHz	Auto-Recovery	–	500V	Intermittent operation	18V/8V		
FA5571N			Auto-Recovery	ZCD Pin					Intermittent operation
FA5572N			Timer-latch						
FA5573N			Auto-Recovery			Linear frequency reduction			
FA5574N			Timer-latch						
FA5577N			Auto-Recovery	VCC Pin					
FA5640N	11 - 26V	Bottom skip control by on-off width detection	Auto-Recovery	ZCD Pin	500V	Intermittent operation	14V/8V	Min. frequency limitation	
FA5641N			Auto-Recovery				10V/8V		
FA5642N			Auto-Recovery				14V/8V		Min. frequency limitation Latch stop function (IS pin)
FA5643N			Auto-Recovery						
FA5644N			Timer-latch						
FA5648N			Auto-Recovery				For High SW frequency		

PKG: SOP-8

● Green mode Quasi-resonant ICs

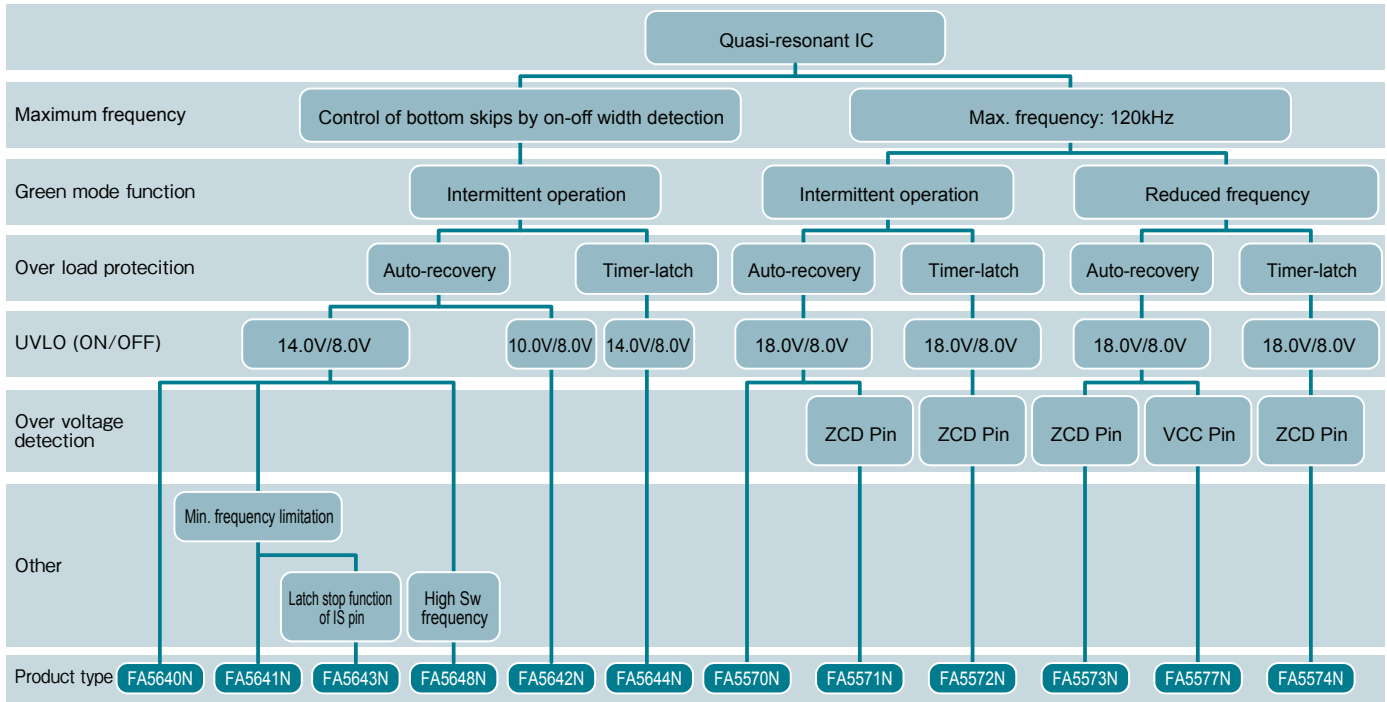

● Block diagram (Main model)

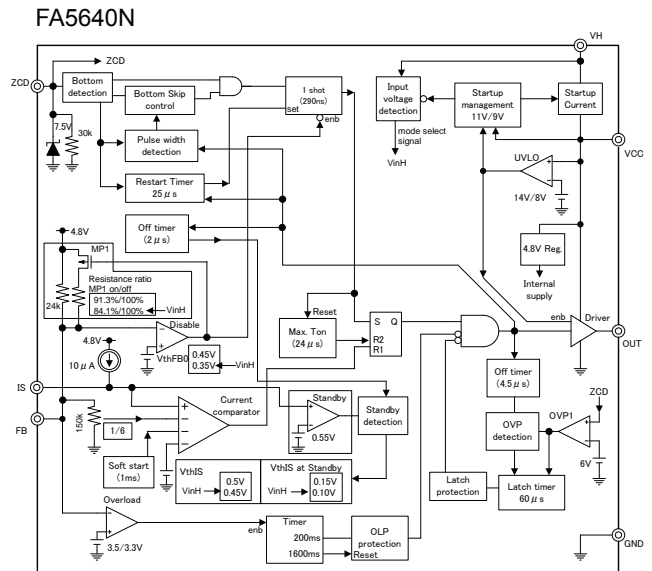
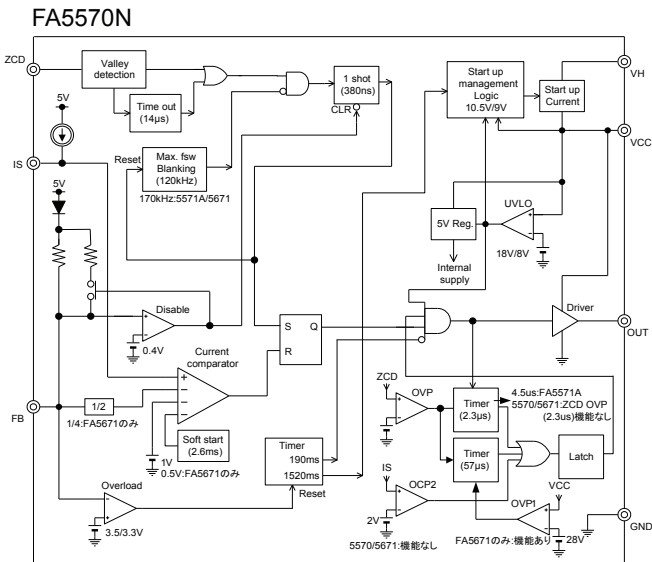

● Power factor correction ICs

Type Name	Input voltage	Duty	Current sense	Under-voltage lockout (ON/OFF)	Frequency	Maximum frequency	Zero Current Detection	FB open short protection	Over voltage protection	Remarks	
CRMPFC											
FA5590N	10 - 26V	-	Negative	9.6V/9.0V	Self-oscillation	Adjustable	Current sense	✓	Voltage-Limit by Pulse width		
FA5591N				13.0V/9.0V							Fixed
FA1A10N				9.6V/8.8V							
FA1A11N				12.4V/8.8V							
FA1A50N				9.6V/8.8V							
FA1A60N				12.5V/7.5V							
FA5696N			9.6V/9.0V	Adjustable	Voltage-Limit by Pulse width and Voltage-Limit						
FA1A00N			9.6V/8.8V	Fixed							
FA1A01N			12.4V/8.8V								
FA5601N			13.0V/9.0V	Adjustable			Voltage-Limit by Pulse width				
FA1A21N			17.3V/8.8V	Fixed	Auxiliary-winding	Voltage-Limit (V _{CC})	For fly Back Over load protection				
CCMPFC											
FA5502P/M	10 - 28V	94%	Negative	16.5V/8.9V	Adjustable	150kHz	-	-	Voltage-Limit		
FA5612N	10 - 26V			9.6V/9.0V	Choice 65/60kHz/jitter (50-70kHz)	-			-	✓	Voltage-Limit by Pulse width
FA5613N				13.0V/9.0V							
FA5614N	10 - 26V			9.6V/9.0V	Choice 130/120kHz/jitter (114-144kHz)	-			-	-	
FA5615N				13.0V/9.0V							

PKG: FA5502 "P":DIP16, "M":SOP-16(M), others are 8pin

IC

● Power factor correction ICs

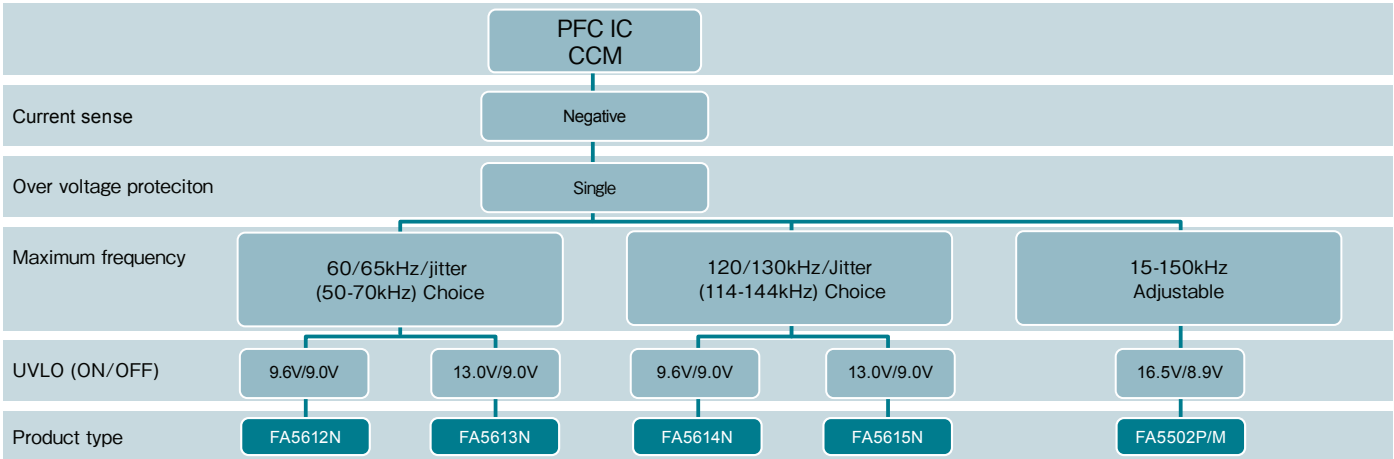
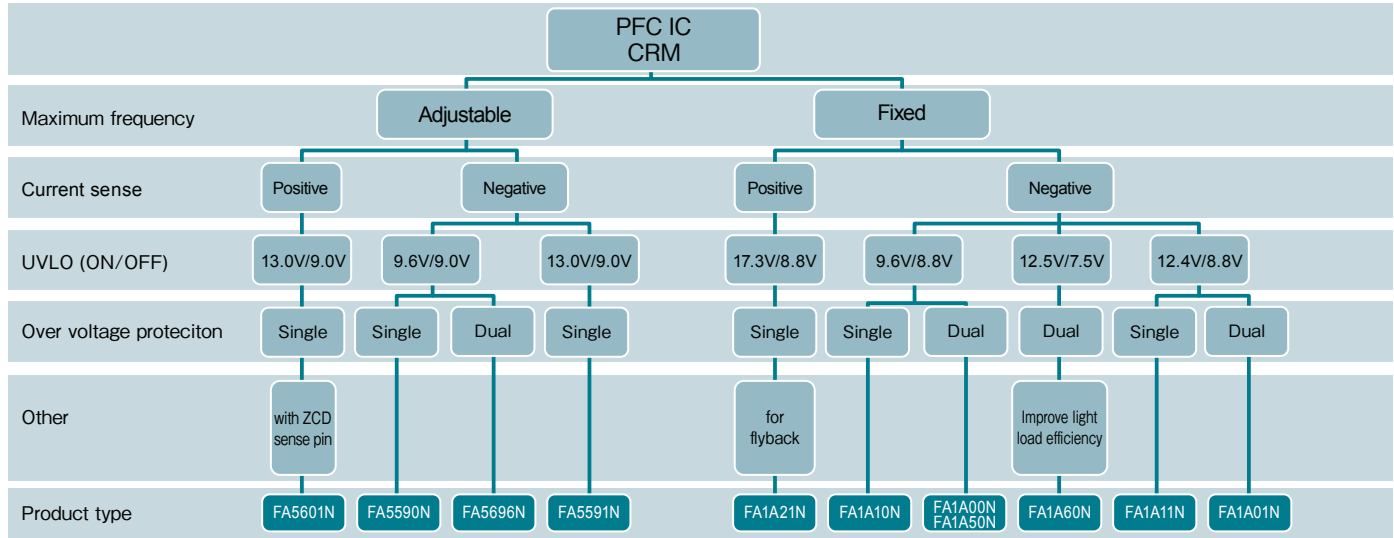

● Block diagram (Main model)

FA5591N

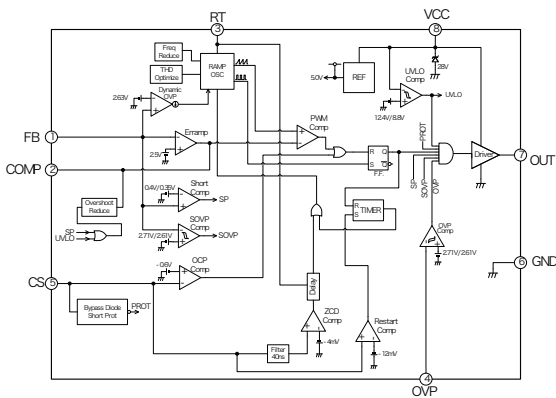

FA5613N, FA5615N

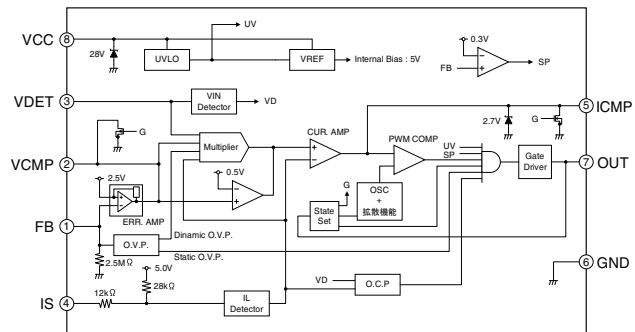

● Current Resonant ICs

Type Name	Control mode	Input voltage	Under-voltage lockout (ON/OFF)	Current sense	Frequency	Maximum frequency	Over load protection	Over voltage protection	Built-in start up circuit	Brown out function	X-Cap discharge function		
FA5760N	Voltage mode	10 - 24V	12.0V/8.9V	Positive	Self-oscillation	200kHz	Auto-Recovery	Timer-latch	500V	Fixed	Without		
FA6A00N						350kHz							
FA6A10N						350kHz							
FA6A11N		14 - 27V	12.0V/9.0V			350kHz	Timer-latch			Auto-Recovery	Timer-latch	Adjustable	With
FA6A30N							350kHz						
FA6A31N		14 - 29V	14.0V/9.0V			450kHz	Auto-Recovery			Auto-Recovery	Fixed	Without	
FA6A19N●													
FA6B20N							With						

●: New Products PKG: SOP-16(N)

● Current Resonant ICs

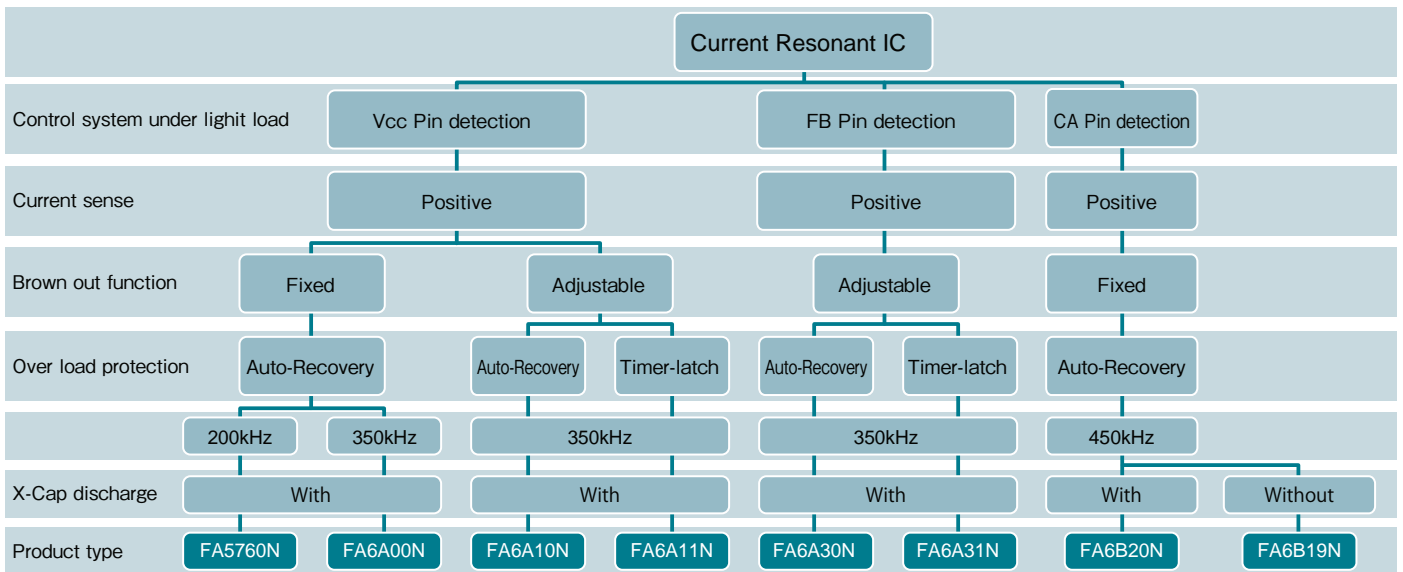

● Block diagram (Main model)

FA5760N

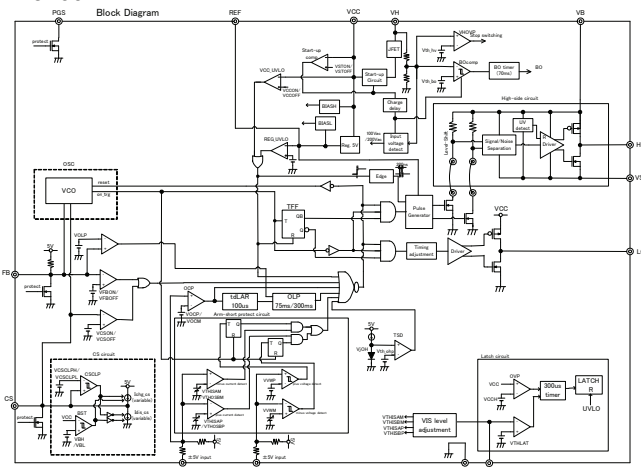

FA6A00N

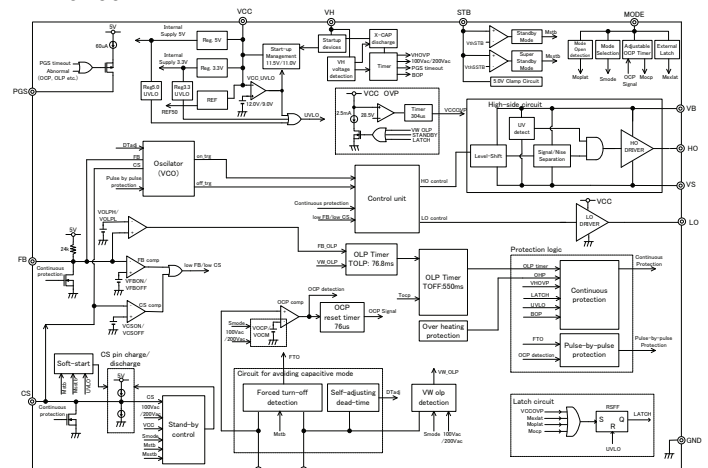

High and Low side driver ICs

Type name	Absolute maximum ratings				Electrical characteristics				
	High side floating supply voltage	Maximum supply voltage	Output current source / sink	Maximum input frequency	Logic"1" / "0" Input voltage level (typ.)	Turn-on/off propagation delay time (typ.)	VCC and VBS supply under-voltage threshold (typ.)	Number of Input terminal	Package
FA5650N	830V	30V	-1.4A/1.8A	500kHz	Logic"1" 2.1V Logic"0" 1.1V	125ns	positive going 8.9V negative going 8.2V	2	SOP-8
FA5651N									SOP-16
FA5752N	624V	24V	High side IHO: -0.62A/1.00A Low side ILO: -0.56A/0.91A		Logic"1" 2.1V Logic"0" 1.3V	130ns			SOP-8

High and Low side driver IC

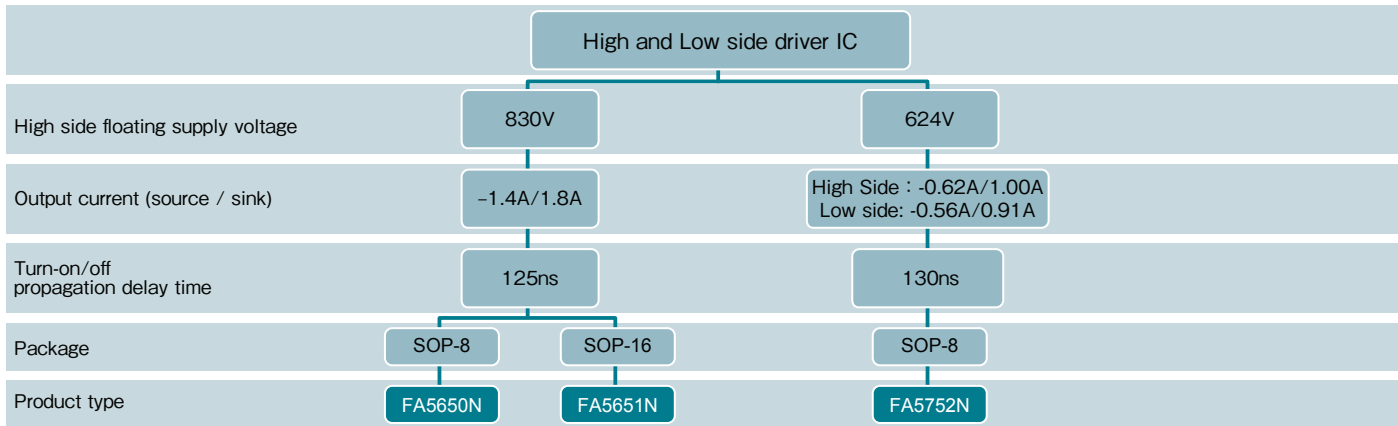

Block diagram (Main model)

FA5650N

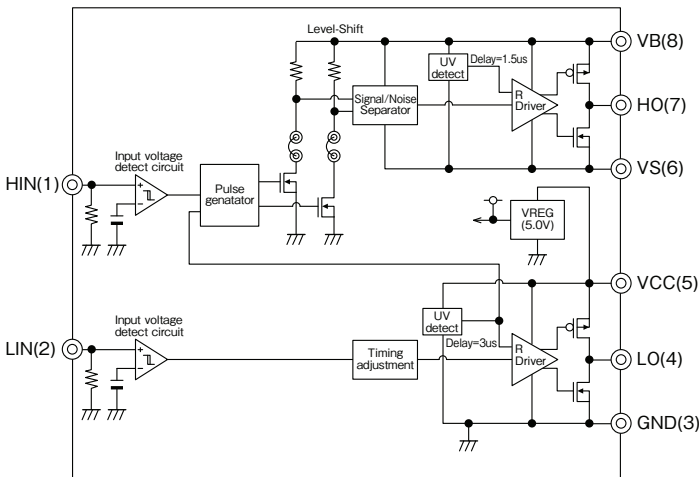

Pin Layout

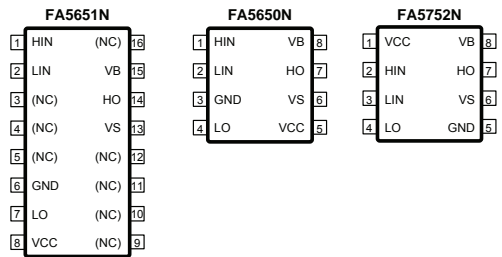

DC/DC Power Supply control ICs

DC/DC Power Supply control ICs

Type Name	Control mode				Output channel	Input voltage	Frequency	Reference Voltage	Operating Ambient Temperature	Output Current	MOSFET Output MOSFET	Package
	Boost	Fly back	Buck	Inverting								
FA7700V	✓	✓			1	2.5 - 18V	50k - 1MHz	0.88V	-30 – +85°C	—	—	TSSOP-8
FA7701V			✓		1	2.5 - 18V	50k - 1MHz	0.88V	-30 – +85°C	—	—	TSSOP-8
FA7703V	✓	✓	✓	✓	2	2.5 - 28V	50k - 1MHz	1.0V	-30 – +85°C	—	—	TSSOP-16
FA3687V	✓	✓	✓	✓	2	2.5 - 18V	300k - 1.5MHz	1.0V	-40 – +85°C	—	—	TSSOP-16
FA7764N/P			✓		1	9 - 45V	30k - 400kHz	1.0V	-20 – +85°C	1.5A	With	N:SOP-8E P:DIP-8

DC/DC Power Supply control ICs

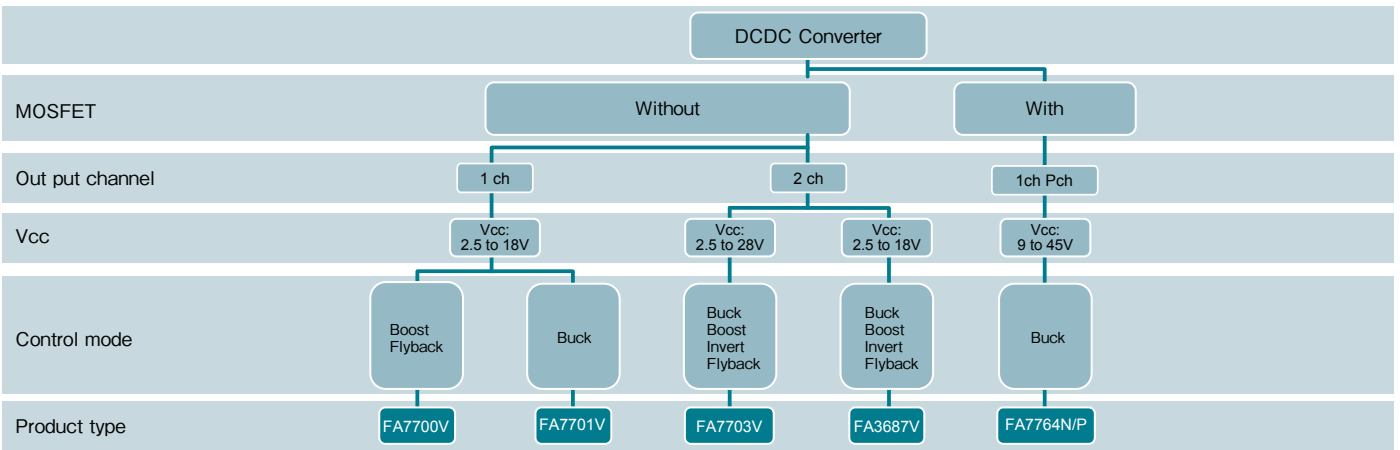

Block diagram (Main model)

FA7764N/P

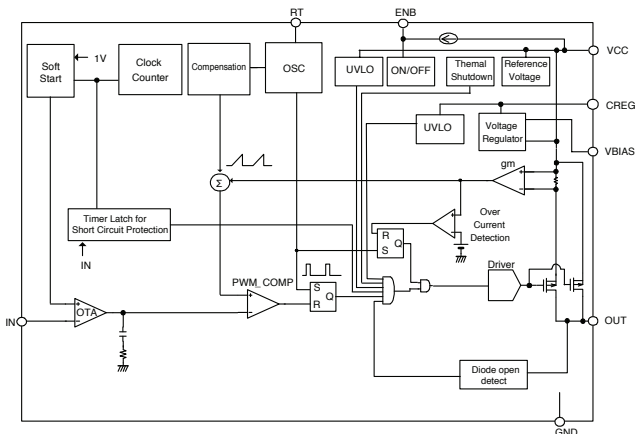

Power MOSFETs



Fuji Electric has a lineup of power MOSFETs ranging from medium to high-voltage types with features such as low power loss, low noise, and low on-resistance.

The "Super J-MOS[®]" Series uses superjunction technology, and was developed primarily for models with a withstand voltage of 600 V.

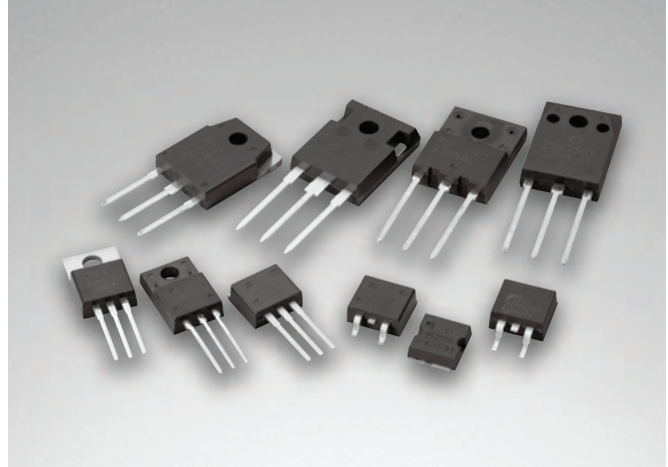

MOSFET Super J MOS[®] S2 Series

■ Concept

Superjunction technology has much improved trade-off characteristics between On-resistance and Breakdown voltage. Super J MOS[®] S2 has the same turn-off loss and turn-off dv/dt capabilities at conventional Super J MOS[®] S1. As a result, It contributes to high efficiency and miniaturization of power supply.

■ Applications

PFC or PWM converter for Server, PC, PCS, UPS, LCD-TV, Lighting and Standard power supply

■ Features & Benefit of Super J MOS[®] S2 series

Feature	Benefit
Low on-state resistance Low switching loss	➔ High efficiency High power density
Low gate charge (Q_G) Low energy stored in output capacitance (E_{oss})	➔ High efficiency at low load
Easy to use (more controllable dv/dt by R_G and Low V_{bs} surge)	➔ Easy to design
100% avalanche tested	➔ High reliability

■ Benefit (Efficiency) of Super J MOS[®] S2 series

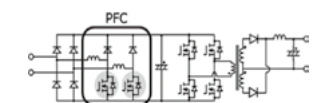
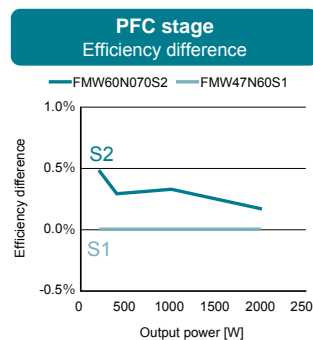

Circuit : PFC+LLC(Exchanged PFC MOS)
Input : 230V AC 50Hz
Output:53.5V/Iout=37A
External R_G : 2 Ω
Sample : 600V/70m Ω max

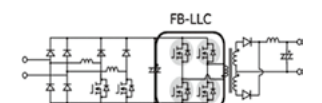
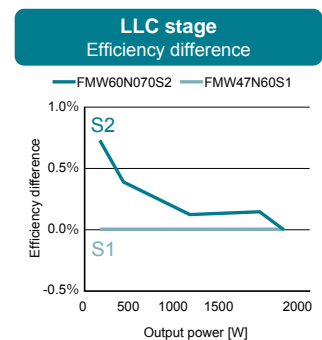

Circuit : PFC+LLC(Exchanged LLC MOS)
Input : 230V AC 50Hz
Output : 49V/Iout=6.12~56.01A
External R_G : 5.1 Ω
Sample : 600V/70m Ω max.

Super J MOS[®] is registered trademarks of Fuji Electric.

■ Features of Super J MOS[®] S2 series

- Low $R_{DS(on)}$ · A 25% lower than our conventional MOSFET (Super J MOS[®] S1)
- Due to low $R_{DS(on)}$, Selectable smaller package
ex) 600V/0.07Ω/TO-3P → 600V/0.07Ω/TO-220F

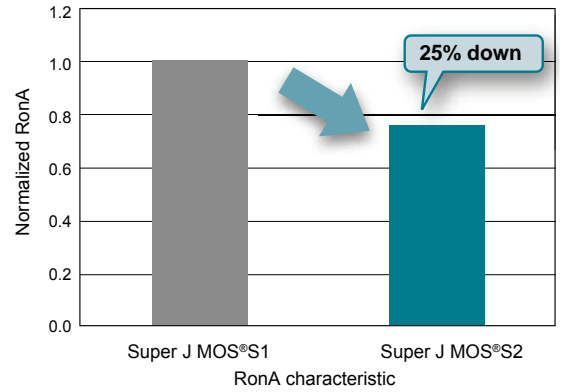
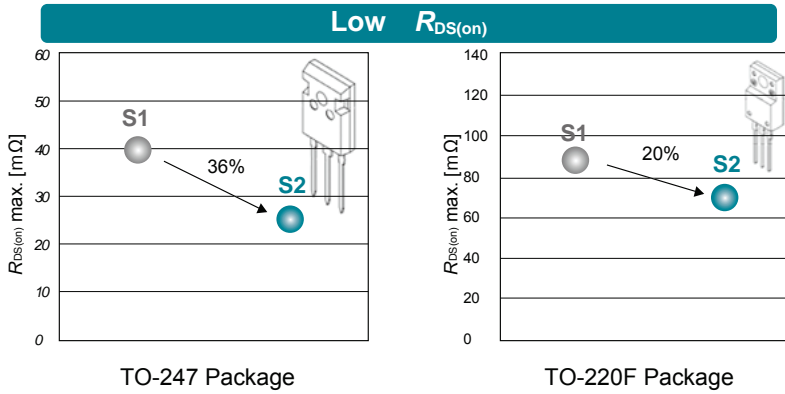

- Low Q_G 30% lower than our conventional MOSFET (Super J MOS[®] S1)
- Low E_{oss} 30% lower than our conventional MOSFET (Super J MOS[®] S1)

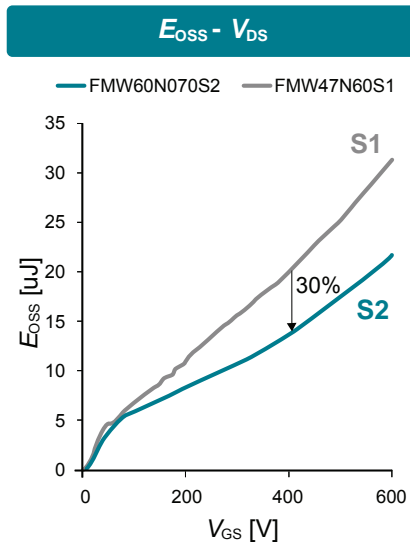
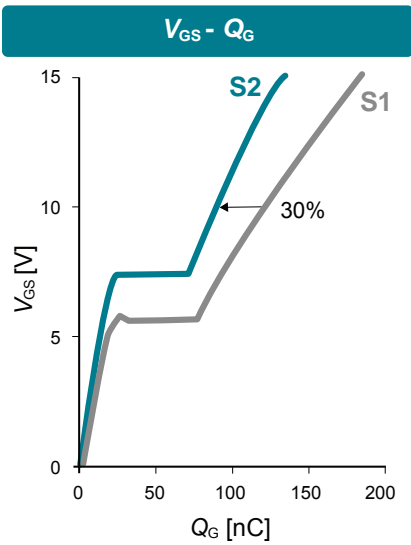

■ Features of Super J MOS[®] S2FD series (Built-in FRED type)

- t_{rr} of S2FD is 50% faster than S2
- High diode recovery ruggedness (High $-di_{DR}/dt$ ruggedness)
- Guaranteed avalanche robustness

■ Applications

For resonant switching topologies in applications like UPS, Server, Telecom, LED lighting, Power conditioner system and Power supply.

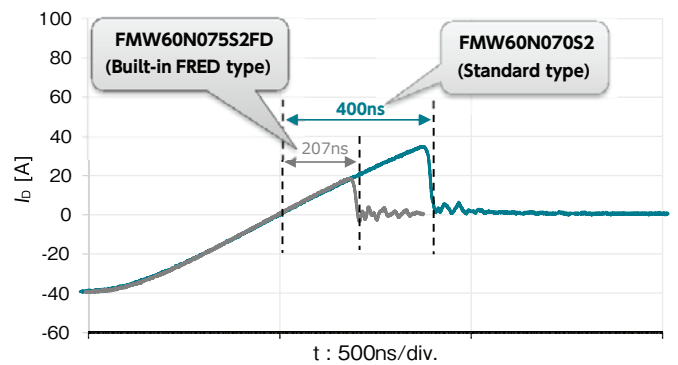

Features of SuperFAP-E³, E^{3S} Series

■ Concept

The second generation Quasi-Planer Junction technology copes with both low loss/noise and usability.
And this technology lets us achieve high performance for power supply's circuit design.

■ Features

- Coping with both low loss and low noise
- Low $R_{DS(on)}$
- High controllability of gate resistance during switching
- Low V_{GS} ringing waveform during switching
- Narrow band of the gate threshold voltage ($3.0 \pm 0.5V$)
- High avalanche durability

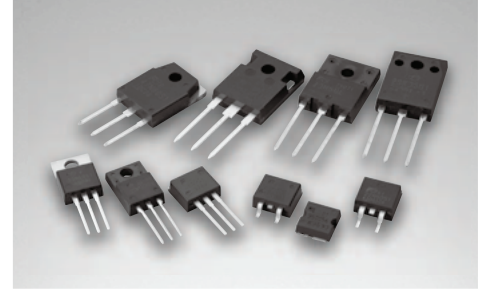

Concept

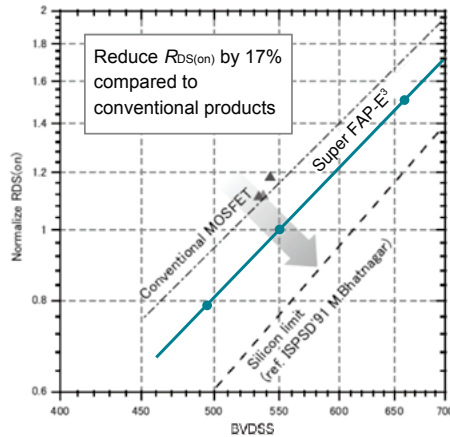
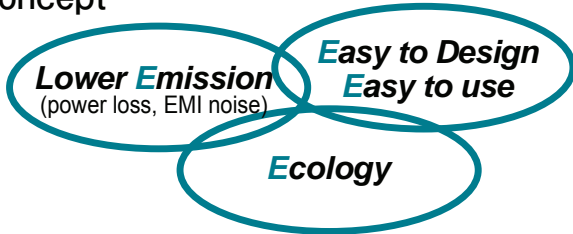

Features of SuperFAP-G Series

The Quasi-Planer Junction technology achieve low $R_{DS(on)}$ and low switching loss (low Q_{GD}).

■ Features

- Low turn off loss 75% lower than our conventional type
- Low Gate charge 60% lower than our conventional type
- High avalanche durability
- Due to low $R_{DS(on)}$, Selectable smaller package
ex) 500V/0.4Ω/TO-3P → 500V/0.38Ω/TO-220

Series map

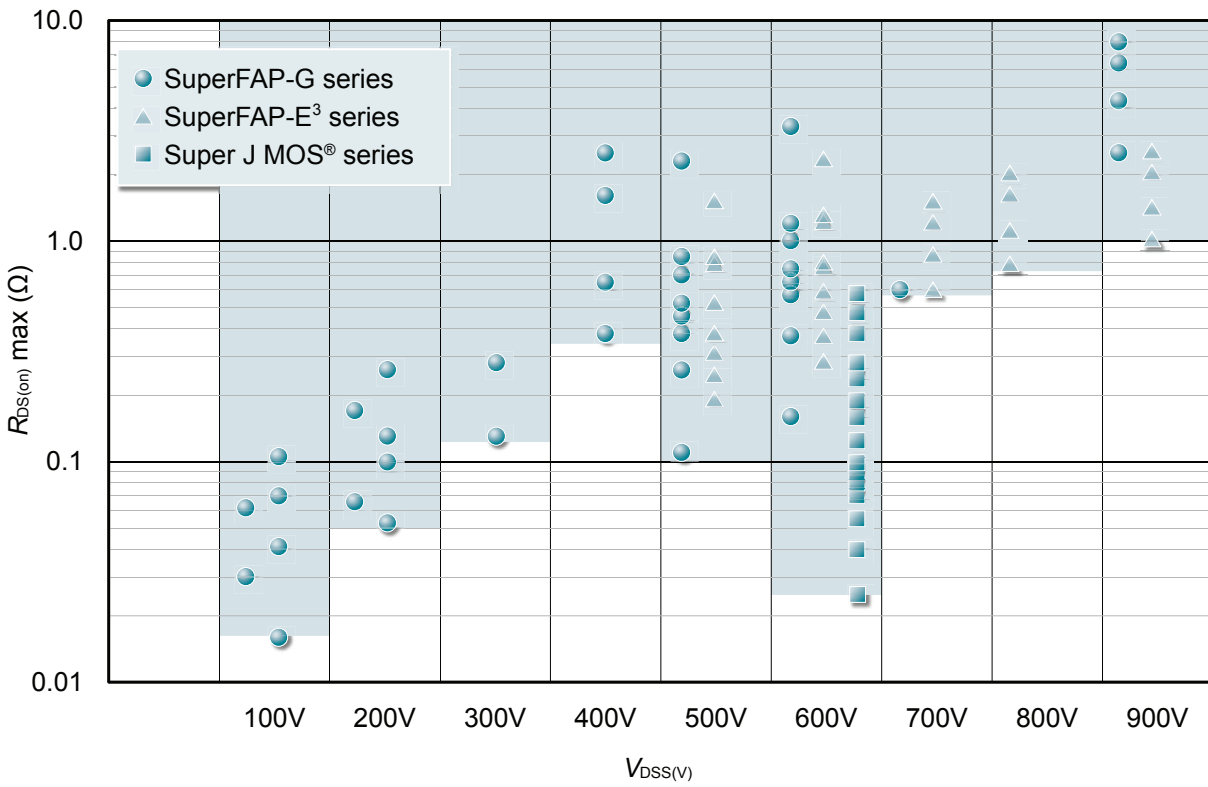

Part numbers

FMV20N60S1 (example)

F	M		V		60	N		190	S2	
Company Symbol	Device code		Package code		Voltage	Polarity		Ron(mΩ)	Series	
Fuji	M	MOSFET	C	T-pack (S)	×1/10	N	N-ch	×1	S2	Super J MOS [®] 2nd Gen.
			H	TO-3P					S2FD	Super J MOS [®] 2nd Gen. (FRED)
			L	DFN8x8					S2A	Super J MOS [®] 2nd Gen. for Automotive
			P	TO-220					S2FDA	Super J MOS [®] 2nd Gen. (FRED) for Automotive
			V	TO-220F (SLS)						
			Y	TO-247						
			W	TO-247-P2						





FMV60N190S2 (example)

F	M		V		20	N		60	S1	
Company Symbol	Device code		Package code		Current	Polarity		Voltage	Series	
Fuji	M	MOSFET	A	TO-220F	×1	N	N-ch	×1/10	S1	Super J MOS [®] 1st Gen.
			C	T-pack (S)					S1FD	Super J MOS [®] 1st Gen. (FRED)
			H	TO-3P					S1A	Super J MOS [®] 1st Gen. for Automotive
			I	T-pack (L)					S1FDA	Super J MOS [®] 1st Gen. (FRED) for Automotive
			P	TO-220					E	SuperFAP-E ³
			R	TO-3PF					ES	SuperFAP-E ^{3S}
			V	TO-220F (SLS)					G	SuperFAP-G
			Y	TO-247					GF	SuperFAP-G (FRED)
			W	TO-247-P2					T2	Trench
									R	3G-Trench

Super J MOS[®] is registered trademarks of Fuji Electric.

Super J MOS[®] S2 series

Low-on resistance, low switching noise and low switching loss

Super J MOS [®] S2 series			TO-220	TO-220F (SLS)	TO-3P(Q)	TO-247-P2	DFN8x8
V_{DS} (V)	$R_{DS(on)}$ (Ω)	I_D (A)					
600	0.3800	10.0	✓	✓			
	0.2800	13.0	✓	✓	✓		
	0.2230	19.2					✓
	0.1900	20.0	✓	✓	✓	✓	
	0.1870	22.7					✓
	0.1600	23.9	✓	✓		✓	
	0.1460	28.7					✓
	0.1250	30.1	✓	✓		✓	
	0.1150	37.1					✓
	0.1030	41.3					✓
	0.0990	38.1	✓	✓		✓	
	0.0910	42.3					✓
	0.0880	42.3	✓	✓		✓	
	0.0790	47.9	✓	✓		✓	
	0.0700	53.2		✓		✓	
	0.0550	64.4				✓	
	0.0400	77.5				✓	
	0.0254	95.5				✓	

600V class

Device type	V_{DSS} Volts	I_D Amps.	I_D (pulse) Amps.	$R_{DS(on)}$ max. Ohms	P_{tot} Watts	V_{GS} Volts	$V_{GS(th)}$ Volts	Q_G typ. nC	Package	Net mass Grams
FMP60N380S2	600	10.0	32.4	0.3800	62	30	3.0±0.5	27.5	TO-220	2.0
FMV60N380S2	600	10.0	32.4	0.3800	20	30	3.0±0.5	27.5	TO-220F(SLS)	1.7
FMP60N280S2	600	13.0	41.6	0.2800	75	30	3.0±0.5	33	TO-220	2.0
FMV60N280S2	600	13.0	41.6	0.2800	26	30	3.0±0.5	33	TO-220F(SLS)	1.7
FMH60N280S2	600	13.0	41.6	0.2800	65	30	3.0±0.5	33	TO-3P(Q)	5.0
● FML60N223S2	600	19.2	56.0	0.2230	108	30	4.0±0.5	37	DFN8x8	0.2
FMP60N190S2	600	20.0	62.0	0.1900	113	30	3.0±0.5	46	TO-220	2.0
FMV60N190S2	600	20.0	62.0	0.1900	38	30	3.0±0.5	46	TO-220F(SLS)	1.7
FMH60N190S2	600	20.0	62.0	0.1900	94	30	3.0±0.5	46	TO-3P(Q)	5.0
FMW60N190S2	600	20.0	62.0	0.1900	94	30	3.0±0.5	46	TO-247-P2	6.0
● FML60N187S2	600	22.7	66.0	0.1870	127	30	4.0±0.5	43	DFN8x8	0.2
FMP60N160S2	600	23.9	71.6	0.1600	127	30	4.0±0.5	43	TO-220	2.0
FMV60N160S2	600	23.9	71.6	0.1600	45	30	4.0±0.5	43	TO-220F(SLS)	1.7
FMW60N160S2	600	23.9	71.6	0.1600	110	30	4.0±0.5	43	TO-247-P2	6.0
● FML60N146S2	600	28.7	83.6	0.1460	159	30	4.0±0.5	53	DFN8x8	0.2
FMP60N125S2	600	30.1	90.8	0.1250	160	30	4.0±0.5	53	TO-220	2.0
FMV60N125S2	600	30.1	90.8	0.1250	57	30	4.0±0.5	53	TO-220F(SLS)	1.7
FMW60N125S2	600	30.1	90.8	0.1250	140	30	4.0±0.5	53	TO-247-P2	6.0
● FML60N115S2	600	37.1	108.0	0.1150	208	30	4.0±0.5	65	DFN8x8	0.2
● FML60N103S2	600	41.3	120.4	0.1030	232	30	4.0±0.5	72	DFN8x8	0.2
FMP60N099S2	600	38.1	117.0	0.0990	210	30	4.0±0.5	65	TO-220	2.0
FMV60N099S2	600	38.1	117.0	0.0990	75	30	4.0±0.5	65	TO-220F(SLS)	1.7
FMW60N099S2	600	38.1	117.0	0.0990	185	30	4.0±0.5	65	TO-247-P2	6.0
● FML60N091S2	600	42.3	125.6	0.0910	263	30	4.0±0.5	80	DFN8x8	0.2

● : New Products

Super J MOS[®] is registered trademarks of Fuji Electric

Letter symbols

V_{DSS} : Drain-source voltage

I_D : Continuous drain current

I_D (pulse): Pulsed drain current

$R_{DS(on)}$: Drain-source on-state resistance

P_{tot} : Maximum power dissipation

V_{GS} : Gate-source voltage

$V_{GS(th)}$: Gate threshold voltage

Q_G : Total gate charge

The Super J MOS[®] series products satisfies the quality assurance level of general consumer use.

If you intend to use the products for equipment requiring higher reliability, such as equipment for automobiles and medical equipment, please contact Fuji Electric.

Do not use the products for equipment requiring strict reliability such as aerospace equipment.

■ 600V class

Device type	V_{DS}	I_D	I_D (pulse)	$R_{DS(on)}$ max.	P_{tot}	V_{GS}	$V_{GS(th)}$	Q_G typ.	Package	Net mass
	Volts	Amps.	Amps.	Ohms	Watts	Volts	Volts	nC		Grams
FMP60N088S2	600	42.3	131	0.0880	235	30	4.0±0.5	72	TO-220	2.0
FMV60N088S2	600	42.3	131	0.0880	85	30	4.0±0.5	72	TO-220F(SLS)	1.7
FMW60N088S2	600	42.3	131	0.0880	205	30	4.0±0.5	72	TO-247-P2	6.0
FMP60N079S2	600	47.9	148	0.0790	270	30	4.0±0.5	80	TO-220	2.0
FMV60N079S2	600	47.9	148	0.0790	95	30	4.0±0.5	80	TO-220F(SLS)	1.7
FMW60N079S2	600	47.9	148	0.0790	235	30	4.0±0.5	80	TO-247-P2	6.0
FMV60N070S2	600	53.2	158	0.0700	110	30	4.0±0.5	90	TO-220F(SLS)	1.7
FMW60N070S2	600	53.2	158	0.0700	270	30	4.0±0.5	90	TO-247-P2	6.0
FMW60N055S2	600	64.4	200	0.0550	340	30	4.0±0.5	110	TO-247-P2	6.0
FMW60N040S2	600	77.5	265	0.0400	435	30	4.0±0.5	147	TO-247-P2	6.0
FMW60N025S2	600	95.5	286.5	0.0254	575	30	4.0±0.5	222	TO-247-P2	6.0





Super J MOS[®] is registered trademarks of Fuji Electric.

The Super J MOS[®] series products satisfies the quality assurance level of general consumer use.

If you intend to use the products for equipment requiring higher reliability, such as equipment for automobiles and medical equipment, please contact Fuji Electric.
Do not use the products for equipment requiring strict reliability such as aerospace equipment.

Super J MOS[®] S2FD series (Built-in FRED type)

Low-on resistance, low switching noise and low switching loss

Super J MOS [®] S2FD Series (Built-in FRED type)			TO-220	TO-220F (SLS)	TO-247-P2	DFN8x8
V_{DS} (V)	$R_{DS(on)}$ (Ω)	I_D (A)				
600	0.191	22.7				✓
	0.170	23.9	✓	✓	✓	
	0.150	28.7				✓
	0.133	30.1	✓	✓	✓	
	0.118	37.1				✓
	0.105	38.1	✓	✓	✓	
	0.104	41.3				✓
	0.094	42.3	✓	✓	✓	
	0.093	42.3				✓
	0.084	47.9	✓	✓	✓	
	0.075	53.2		✓	✓	
	0.059	64.4			✓	
	0.043	77.5			✓	
0.027	95.5			✓		

600V class

Device type	V_{bss} Volts	I_D Amps.	I_D (pulse) Amps.	$R_{DS(on)}$ max. Ohms	P_{tot} Watts	V_{GS} Volts	$V_{GS(th)}$ Volts	Q_G typ. nC	t_r typ. ns	Package	Net mass Grams
● FML60N191S2FD	600	22.7	66	0.191	127	30	4.0±1.0	48	150	DFN8x8	0.2
FMP60N170S2FD	600	23.9	71.6	0.170	127	30	4.0±1.0	48	150	TO-220	2.0
FMV60N170S2FD	600	23.9	71.6	0.170	45	30	4.0±1.0	48	150	TO-220F(SLS)	1.7
FMW60N170S2FD	600	23.9	71.6	0.170	110	30	4.0±1.0	48	150	TO-247-P2	6.0
● FML60N150S2FD	600	28.7	83.6	0.150	159	30	4.0±1.0	59	160	DFN8x8	0.2
FMP60N133S2FD	600	30.1	90.8	0.133	160	30	4.0±1.0	59	160	TO-220	2.0
FMV60N133S2FD	600	30.1	90.8	0.133	57	30	4.0±1.0	59	160	TO-220F(SLS)	1.7
FMW60N133S2FD	600	30.1	90.8	0.133	140	30	4.0±1.0	59	160	TO-247-P2	6.0
● FML60N118S2FD	600	37.1	108	0.118	208	30	4.0±1.0	75	174	DFN8x8	0.2
FMP60N105S2FD	600	38.1	117	0.105	210	30	4.0±1.0	75	174	TO-220	2.0
FMV60N105S2FD	600	38.1	117	0.105	75	30	4.0±1.0	75	174	TO-220F(SLS)	1.7
FMW60N105S2FD	600	38.1	117	0.105	185	30	4.0±1.0	75	174	TO-247-P2	6.0
● FML60N104S2FD	600	41.3	121.6	0.104	232	30	4.0±1.0	83	185	DFN8x8	0.2
FMP60N094S2FD	600	42.3	131	0.094	235	30	4.0±1.0	83	185	TO-220	2.0
FMV60N094S2FD	600	42.3	131	0.094	85	30	4.0±1.0	83	185	TO-220F(SLS)	1.7
FMW60N094S2FD	600	42.3	131	0.094	205	30	4.0±1.0	83	185	TO-247-P2	6.0
● FML60N093S2FD	600	42.3	125.6	0.093	263	30	4.0±1.0	93	190	DFN8x8	0.2
FMP60N084S2FD	600	47.9	148	0.084	270	30	4.0±1.0	93	190	TO-220	2.0
FMV60N084S2FD	600	47.9	148	0.084	95	30	4.0±1.0	93	190	TO-220F(SLS)	1.7
FMW60N084S2FD	600	47.9	148	0.084	235	30	4.0±1.0	93	190	TO-247-P2	6.0
FMV60N075S2FD	600	53.2	158	0.075	110	30	4.0±1.0	97	207	TO-220F(SLS)	1.7
FMW60N075S2FD	600	53.2	158	0.075	270	30	4.0±1.0	97	207	TO-247-P2	6.0
FMW60N059S2FD	600	64.4	200	0.059	340	30	4.0±1.0	129	215	TO-247-P2	6.0
FMW60N043S2FD	600	77.5	265	0.043	435	30	4.0±1.0	177	250	TO-247-P2	6.0
FMW60N027S2FD	600	95.5	286.5	0.027	575	30	4.0±1.0	256	288	TO-247-P2	6.0

●: New Product





Super J MOS[®] is registered trademarks of Fuji Electric.

The Super J MOS[®] series products satisfies the quality assurance level of general consumer use.

If you intend to use the products for equipment requiring higher reliability, such as equipment for automobiles and medical equipment, please contact Fuji Electric.
Do not use the products for equipment requiring strict reliability such as aerospace equipment.

Super J MOS[®] S1 series

Low-on resistance, low switching noise and low switching loss

Super J MOS [®] S1 series			TO-220	TO-220F (SLS)	TO-3P(Q)	TO-247-P2
V_{DS} (V)	$R_{DS(on)}$ (Ω)	I_D (A)				
600	0.580	6.5	✓	✓		
	0.470	8	✓	✓		
	0.380	10	✓	✓		
	0.280	13	✓	✓	✓	
	0.230	15	✓	✓	✓	✓
	0.190	20	✓	✓	✓	✓
	0.160	22	✓	✓	✓	✓
	0.125	30	✓	✓	✓	✓
	0.099	35		✓	✓	✓
	0.088	40		✓	✓	✓
	0.070	47			✓	✓
	0.055	57				✓
	0.040	68				✓

600V class



Device type	V_{DSS} Volts	I_D Amps.	I_D (pulse) Amps.	$R_{DS(on)}$ max. Ohms	P_{Tot} Watts	V_{GS} Volts	$V_{GS(th)}$ Volts	Q_G typ. nC	Package	Net mass Grams
FMP07N60S1	600	6.5	19.5	0.580	60	30	3±0.5	21	TO-220	2.0
FMV07N60S1	600	6.5	19.5	0.580	21	30	3±0.5	21	TO-220F(SLS)	1.7
FMP08N60S1	600	8	24	0.470	70	30	3±0.5	25	TO-220	2.0
FMV08N60S1	600	8	24	0.470	25	30	3±0.5	25	TO-220F(SLS)	1.7
FMP10N60S1	600	10	30	0.380	90	30	3±0.5	28	TO-220	2.0
FMV10N60S1	600	10	30	0.380	32	30	3±0.5	28	TO-220F(SLS)	1.7
FMP13N60S1	600	13	39	0.280	120	30	3±0.5	35	TO-220	2.0
FMV13N60S1	600	13	39	0.280	43	30	3±0.5	35	TO-220F(SLS)	1.7
FMH13N60S1	600	13	39	0.280	105	30	3±0.5	35	TO-3P(Q)	5.0
FMP15N60S1	600	15	45	0.230	135	30	3±0.5	43	TO-220	2.0
FMV15N60S1	600	15	45	0.230	48	30	3±0.5	43	TO-220F(SLS)	1.7
FMH15N60S1	600	15	45	0.230	115	30	3±0.5	43	TO-3P(Q)	5.0
FMW15N60S1	600	15	45	0.230	115	30	3±0.5	43	TO-247-P2	6.0
FMP20N60S1	600	20	60	0.190	150	30	3±0.5	48	TO-220	2.0
FMV20N60S1	600	20	60	0.190	60	30	3±0.5	48	TO-220F(SLS)	1.7
FMH20N60S1	600	20	60	0.190	130	30	3±0.5	48	TO-3P(Q)	5.0
FMW20N60S1	600	20	60	0.190	130	30	3±0.5	48	TO-247-P2	6.0
FMP22N60S1	600	22	66	0.160	195	30	3±0.5	57	TO-220	2.0
FMV22N60S1	600	22	66	0.160	70	30	3±0.5	57	TO-220F(SLS)	1.7
FMH22N60S1	600	22	66	0.160	170	30	3±0.5	57	TO-3P(Q)	5.0
FMW22N60S1	600	22	66	0.160	170	30	3±0.5	57	TO-247-P2	6.0
FMP30N60S1	600	30	90	0.125	250	30	3±0.5	73	TO-220	2.0
FMV30N60S1	600	30	90	0.125	90	30	3±0.5	73	TO-220F(SLS)	1.7
FMH30N60S1	600	30	90	0.125	220	30	3±0.5	73	TO-3P(Q)	5.0
FMW30N60S1	600	30	90	0.125	220	30	3±0.5	73	TO-247-P2	6.0
FMV35N60S1	600	35	105	0.099	110	30	3±0.5	87	TO-220F(SLS)	1.7
FMH35N60S1	600	35	105	0.099	270	30	3±0.5	87	TO-3P(Q)	5.0
FMW35N60S1	600	35	105	0.099	270	30	3±0.5	87	TO-247-P2	6.0
FMV40N60S1	600	40	120	0.088	130	30	3±0.5	100	TO-220F(SLS)	1.7
FMH40N60S1	600	40	120	0.088	315	30	3±0.5	100	TO-3P(Q)	5.0
FMW40N60S1	600	40	120	0.088	315	30	3±0.5	100	TO-247-P2	6.0
FMH47N60S1	600	47	141	0.070	390	30	3±0.5	125	TO-3P(Q)	5.0
FMW47N60S1	600	47	141	0.070	390	30	3±0.5	125	TO-247-P2	6.0
FMW57N60S1	600	57	171	0.055	445	30	3±0.5	153	TO-247-P2	6.0
FMW79N60S1	600	68	204	0.040	545	30	3±0.5	203	TO-247-P2	6.0

Super J MOS[®] is registered trademarks of Fuji Electric.

The Super J MOS[®] series products satisfies the quality assurance level of general consumer use. If you intend to use the products for equipment requiring higher reliability, such as equipment for automobiles and medical equipment, please contact Fuji Electric. Do not use the products for equipment requiring strict reliability such as aerospace equipment.

Super J MOS[®] S1FD series (Built-in FRED type)

Low-on resistance, low switching noise and low switching loss

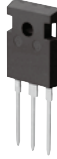
Super J MOS [®] S1FD series (Built-in FRED type)			TO-220	TO-220F (SLS)	TO-3P(Q)	TO-247-P2
						
V_{DS} (V)	$R_{DS(on)}$ (Ω)	I_D (A)				
600	0.200	20	✓	✓	✓	✓
	0.170	22	✓	✓	✓	✓
	0.132	30	✓	✓	✓	✓
	0.105	35		✓	✓	✓
	0.093	40			✓	✓
	0.074	47			✓	✓
	0.058	57				✓
	0.042	68				✓

600V class

Device type	V_{DSS}	I_D	I_D (pulse)	$R_{DS(on)}$ max.	P_{tot}	V_{GS}	$V_{GS(th)}$	Q_G typ.	t_{rr} typ.	Package	Net mass Grams
	Volts	Amps.	Amps.	Ohms	Watts	Volts	Volts	nC	ns		
FMP20N60S1FD	600	20	60	0.200	150	30	4.0±1.0	52	150	TO-220	2.0
FMV20N60S1FD	600	20	60	0.200	60	30	4.0±1.0	52	150	TO-220F(SLS)	1.7
FMH20N60S1FD	600	20	60	0.200	130	30	4.0±1.0	52	150	TO-3P(Q)	5.0
FMW20N60S1FD	600	20	60	0.200	130	30	4.0±1.0	52	150	TO-247-P2	6.0
FMP22N60S1FD	600	22	66	0.170	195	30	4.0±1.0	58	165	TO-220	2.0
FMV22N60S1FD	600	22	66	0.170	70	30	4.0±1.0	58	165	TO-220F(SLS)	1.7
FMH22N60S1FD	600	22	66	0.170	170	30	4.0±1.0	58	165	TO-3P(Q)	5.0
FMW22N60S1FD	600	22	66	0.170	170	30	4.0±1.0	58	165	TO-247-P2	6.0
FMP30N60S1FD	600	30	90	0.132	250	30	4.0±1.0	73	180	TO-220	2.0
FMV30N60S1FD	600	30	90	0.132	90	30	4.0±1.0	73	180	TO-220F(SLS)	1.7
FMH30N60S1FD	600	30	90	0.132	220	30	4.0±1.0	73	180	TO-3P(Q)	5.0
FMW30N60S1FD	600	30	90	0.132	220	30	4.0±1.0	73	180	TO-247-P2	6.0
FMV35N60S1FD	600	35	105	0.105	110	30	4.0±1.0	92	185	TO-220F(SLS)	1.7
FMH35N60S1FD	600	35	105	0.105	270	30	4.0±1.0	92	185	TO-3P(Q)	5.0
FMW35N60S1FD	600	35	105	0.105	270	30	4.0±1.0	92	185	TO-247-P2	6.0
FMH40N60S1FD	600	40	120	0.093	315	30	4.0±1.0	104	200	TO-3P(Q)	5.0
FMW40N60S1FD	600	40	120	0.093	315	30	4.0±1.0	104	200	TO-247-P2	6.0
FMH47N60S1FD	600	47	141	0.074	390	30	4.0±1.0	127	210	TO-3P(Q)	5.0
FMW47N60S1FD	600	47	141	0.074	390	30	4.0±1.0	127	210	TO-247-P2	6.0
FMW57N60S1FD	600	68	171	0.058	445	30	4.0±1.0	158	220	TO-247-P2	6.0
FMW79N60S1FD	600	68	204	0.042	545	30	4.0±1.0	209	230	TO-247-P2	6.0







Super J MOS[®] is registered trademarks of Fuji Electric.

The Super J MOS[®] series products satisfies the quality assurance level of general consumer use.

If you intend to use the products for equipment requiring higher reliability, such as equipment for automobiles and medical equipment, please contact Fuji Electric. Do not use the products for equipment requiring strict reliability such as aerospace equipment.

■ SuperFAP-E³ series

Low-on resistance and low switching noise

SuperFAP-E ³ series			TO-220	TO-220 (SLS)	TO-3P (Q)	TO-3PF	T-Pack(L)	T-Pack(S)
V_{DS} (V)	$R_{DS(on)}$ (Ω)	I_D (A)						
500	1.5	5	✓	✓			✓	✓
	0.85	6.5	✓	✓			✓	✓
	0.79	7.5	✓	✓			✓	✓
	0.52	12	✓	✓			✓	✓
	0.38	16	✓	✓	✓		✓	✓
	0.31	20	✓	✓	✓		✓	✓
	0.245	23		✓	✓	✓		
	0.19	28			✓	✓		
600	2.3	3	✓	✓			✓	✓
	1.3	6	✓	✓			✓	✓
	1.2	6	✓	✓				
	0.79	10	✓	✓			✓	✓
	0.75	11	✓	✓			✓	✓
	0.58	13	✓	✓			✓	✓
	0.47	16	✓	✓			✓	✓
	0.365	19		✓	✓	✓		
	0.28	23			✓	✓		
650	1.47	7		✓				
	0.97	9		✓				
700	1.5	7		✓	✓			
	1.2	9		✓	✓			
	0.85	11		✓	✓			
	0.59	15		✓				
800	2	6		✓	✓		✓	✓
	1.6	8		✓	✓		✓	✓
	1.1	10		✓	✓			
	0.78	13		✓	✓			
900	2.5	6		✓	✓		✓	✓
	2	7		✓	✓		✓	✓
	1.4	9		✓	✓	✓		
	1	11		✓	✓	✓		

MOSFET

SuperFAP-E³ series

500V class

Device type	V_{DS}	I_D	I_D (pulse)	$R_{DS(on)}$ max. *1	P_{tot} *2	V_{GS}	$V_{GS(th)}$	Q_G typ. nC	Package	Net mass Grams
	Volts	Amps.	Amps.	Ohms	Watts	Volts	Volts			
FMP05N50E	500	5	20	1.5	60	30	3±0.5	21	TO-220	2.0
FMV05N50E	500	5	20	1.5	21	30	3±0.5	21	TO-220F(SLS)	1.7
FMI05N50E	500	5	20	1.5	60	30	3±0.5	21	T-Pack(L)	1.6
FMC05N50E	500	5	20	1.5	60	30	3±0.5	21	T-Pack(S)	1.6
FMP07N50E	500	6.5	26	0.85	90	30	3±0.5	32	TO-220	2.0
FMV07N50E	500	6.5	26	0.85	32	30	3±0.5	32	TO-220F(SLS)	1.7
FMI07N50E	500	6.5	26	0.85	90	30	3±0.5	32	T-Pack(L)	1.6
FMC07N50E	500	6.5	26	0.85	90	30	3±0.5	32	T-Pack(S)	1.6
FMP08N50E	500	7.5	30	0.79	105	30	3±0.5	35	TO-220	2.0
FMV08N50E	500	7.5	30	0.79	37	30	3±0.5	35	TO-220F(SLS)	1.7
FMP12N50E	500	12	48	0.52	165	30	3±0.5	60	TO-220	2.0
FMV12N50E	500	12	48	0.52	60	30	3±0.5	60	TO-220F(SLS)	1.7
FMI12N50E	500	12	48	0.52	165	30	3±0.5	60	T-Pack(L)	1.6
FMC12N50E	500	12	48	0.52	165	30	3±0.5	60	T-Pack(S)	1.6
FMP16N50E	500	16	64	0.38	225	30	3±0.5	60	TO-220	2.0
FMV16N50E	500	16	64	0.38	80	30	3±0.5	60	TO-220F(SLS)	1.7
FMI16N50E	500	16	64	0.38	225	30	3±0.5	60	T-Pack(L)	1.6
FMC16N50E	500	16	64	0.38	225	30	3±0.5	60	T-Pack(S)	1.6
FMH16N50E	500	16	64	0.38	195	30	3±0.5	60	TO-3P(Q)	5.1
FMP20N50E	500	20	80	0.31	270	30	3±0.5	77	TO-220	2.0
FMV20N50E	500	20	80	0.31	95	30	3±0.5	77	TO-220F(SLS)	1.7
FMI20N50E	500	20	80	0.31	270	30	3±0.5	77	T-Pack(L)	1.6
FMC20N50E	500	20	80	0.31	270	30	3±0.5	77	T-Pack(S)	1.6
FMH20N50E	500	20	80	0.31	235	30	3±0.5	77	TO-3P(Q)	5.1
FMV23N50E	500	23	92	0.245	130	30	3±0.5	93	TO-220F(SLS)	1.7
FMH23N50E	500	23	92	0.245	315	30	3±0.5	93	TO-3P(Q)	5.1
FMR23N50E	500	23	92	0.245	150	30	3±0.5	93	TO-3PF	6.0
FMH28N50E	500	28	112	0.19	400	30	3±0.5	130	TO-3P(Q)	5.1
FMR28N50E	500	28	112	0.19	200	30	3±0.5	130	TO-3PF	6.0

*1 $R_{DS(on)}$: $V_{GS}=10V$, *2 P_{tot} : $T_C=25^\circ C$

The SuperFAP-E³ series products satisfies the quality assurance level of general consumer use.

If you intend to use the products for equipment requiring higher reliability, such as equipment for automobiles and medical equipment, please contact Fuji Electric.
Do not use the products for equipment requiring strict reliability such as aerospace equipment.

SuperFAP-E³ series

600 – 800V class

Device type	V_{DS}	I_D	I_D (pulse)	$R_{DS(on)}$	P_{tot} *2	V_{GS}	$V_{GS(th)}$	Q_G	Package	Net mass Grams
	Volts	Amps.	Amps.	Ohms	Watts	Volts	Volts	typ. nC		
FMP03N60E	600	3	12	2.3	60	30	3±0.5	21.5	TO-220	2.0
FMV03N60E	600	3	12	2.3	21	30	3±0.5	21.5	TO-220F(SLS)	1.7
FMI03N60E	600	3	12	2.3	60	30	3±0.5	21.5	T-Pack(L)	1.6
FMC03N60E	600	3	12	2.3	60	30	3±0.5	21.5	T-Pack(S)	1.6
FMP05N60E	600	5.5	22	1.3	90	30	3±0.5	33	TO-220	2.0
FMV05N60E	600	5.5	22	1.3	32	30	3±0.5	33	TO-220F(SLS)	1.7
FMI05N60E	600	5.5	22	1.3	90	30	3±0.5	33	T-Pack(L)	1.6
FMC05N60E	600	5.5	22	1.3	90	30	3±0.5	33	T-Pack(S)	1.6
FMP06N60E	600	6	24	1.2	105	30	3±0.5	35	TO-220	2.0
FMV06N60E	600	6	24	1.2	37	30	3±0.5	35	TO-220F(SLS)	1.7
FMP10N60E	600	10	40	0.79	165	30	3±0.5	47	TO-220	2.0
FMV10N60E	600	10	40	0.79	60	30	3±0.5	47	TO-220F(SLS)	1.7
FMI10N60E	600	10	40	0.79	165	30	3±0.5	47	T-Pack(L)	1.6
FMC10N60E	600	10	40	0.79	165	30	3±0.5	47	T-Pack(S)	1.6
FMP11N60E	600	11	44	0.75	180	30	3±0.5	48.5	TO-220	2.0
FMV11N60E	600	11	44	0.75	65	30	3±0.5	48.5	TO-220F(SLS)	1.7
FMI11N60E	600	11	44	0.75	180	30	3±0.5	48.5	T-Pack(L)	1.6
FMC11N60E	600	11	44	0.75	180	30	3±0.5	48.5	T-Pack(S)	1.6
FMP13N60E	600	13	52	0.58	225	30	3±0.5	60	TO-220	2.0
FMV13N60E	600	13	52	0.58	80	30	3±0.5	60	TO-220F(SLS)	1.7
FMI13N60E	600	13	52	0.58	225	30	3±0.5	60	T-Pack(L)	1.6
FMC13N60E	600	13	52	0.58	225	30	3±0.5	60	T-Pack(S)	1.6
FMP16N60E	600	16	64	0.47	270	30	3±0.5	76	TO-220	2.0
FMV16N60E	600	16	64	0.47	95	30	3±0.5	76	TO-220F(SLS)	1.7
FMI16N60E	600	16	64	0.47	270	30	3±0.5	76	T-Pack(L)	1.6
FMC16N60E	600	16	64	0.47	270	30	3±0.5	76	T-Pack(S)	1.6
FMV19N60E	600	19	76	0.365	130	30	3±0.5	105	TO-220F(SLS)	1.7
FMH19N60E	600	19	76	0.365	315	30	3±0.5	105	TO-3P(Q)	5.1
FMR19N60E	600	19	76	0.365	150	30	3±0.5	105	TO-3PF	6.0
FMH23N60E	600	23	92	0.28	400	30	3±0.5	130	TO-3P(Q)	5.1
FMR23N60E	600	23	92	0.28	200	30	3±0.5	130	TO-3PF	6.0
FMV07N65E	650	7	28	1.47	37	30	3±0.5	35	TO-220F(SLS)	1.7
FMV09N65E	650	9	36	0.97	60	30	3±0.5	47	TO-220F(SLS)	1.7
FMV07N70E	700	7	28	1.5	48	30	4±0.5	32	TO-220F(SLS)	1.7
FMH07N70E	700	7	28	1.5	115	30	4±0.5	32	TO-3P(Q)	5.1
FMV09N70E	700	9	36	1.2	60	30	4±0.5	38	TO-220F(SLS)	1.7
FMH09N70E	700	9	36	1.2	145	30	4±0.5	38	TO-3P(Q)	5.1
FMV11N70E	700	11	44	0.85	85	30	4±0.5	50	TO-220F(SLS)	1.7
FMH11N70E	700	11	44	0.85	205	30	4±0.5	50	TO-3P(Q)	5.1
FMV15N70E	700	15	60	0.59	120	30	4±0.5	66	TO-220F(SLS)	1.7
FMV06N80E	800	6	24	2.0	48	30	4±0.5	32	TO-220F(SLS)	1.7
FMH06N80E	800	6	24	2.0	115	30	4±0.5	32	TO-3P(Q)	5.1
FMI06N80E	800	6	24	2.0	135	30	4±0.5	32	T-Pack(L)	1.6
FMC06N80E	800	6	24	2.0	135	30	4±0.5	32	T-Pack(S)	1.6
FMV08N80E	800	8	32	1.6	60	30	4±0.5	38	TO-220F(SLS)	1.7
FMH08N80E	800	8	32	1.6	145	30	4±0.5	38	TO-3P(Q)	5.1
FMI08N80E	800	8	32	1.6	165	30	4±0.5	38	T-Pack(L)	1.6
FMC08N80E	800	8	32	1.6	165	30	4±0.5	38	T-Pack(S)	1.6
FMV10N80E	800	10	40	1.1	85	30	4±0.5	50	TO-220F(SLS)	1.7
FMH10N80E	800	10	40	1.1	205	30	4±0.5	50	TO-3P(Q)	5.1
FMV13N80E	800	13	52	0.78	120	30	4±0.5	66	TO-220F(SLS)	1.7
FMH13N80E	800	13	52	0.78	285	30	4±0.5	66	TO-3P(Q)	5.1

*1 $R_{DS(on)}$: $V_{GS}=10V$, *2 P_{tot} : $T_C=25^{\circ}C$

SuperFAP-E³ series







900V class

Device type	V _{DSS}	I _D	I _{D (pulse)}	R _{DS (on)} max. *1	P _{tot} *2	V _{GS}	V _{GS (th)}	Q _G typ. nC	Package	Net mass
	Volts	Amps.	Amps.	Ohms	Watts	Volts	Volts			Grams
FMH06N90E	900	6	24	2.5	115	30	4±0.5	33	TO-3P(Q)	5.1
FMV06N90E	900	6	24	2.5	48	30	4±0.5	33	TO-220F(SLS)	1.7
FMI06N90E	900	6	24	2.5	135	30	4±0.5	33	T-Pack(L)	1.6
FMC06N90E	900	6	24	2.5	135	30	4±0.5	33	T-Pack(S)	1.6
FMH07N90E	900	7	28	2.0	145	30	4±0.5	39	TO-3P(Q)	5.1
FMV07N90E	900	7	28	2.0	60	30	4±0.5	39	TO-220F(SLS)	1.7
FMI07N90E	900	7	28	2.0	165	30	4±0.5	39	T-Pack(L)	1.6
FMC07N90E	900	7	28	2.0	165	30	4±0.5	39	T-Pack(S)	1.6
FMH09N90E	900	9	36	1.4	205	30	4±0.5	50	TO-3P(Q)	5.1
FMV09N90E	900	9	36	1.4	85	30	4±0.5	50	TO-220F(SLS)	1.7
FMR09N90E	900	9	36	1.4	100	30	4±0.5	50	TO-3PF	6.0
FMH11N90E	900	11	44	1.0	285	30	4±0.5	60	TO-3P(Q)	5.1
FMV11N90E	900	11	44	1.0	120	30	4±0.5	60	TO-220F(SLS)	1.7
FMR11N90E	900	11	44	1.0	135	30	4±0.5	60	TO-3PF	6.0

*1 R_{DS (on)} : V_{GS}=10V, *2 P_{tot}: T_C=25°C

■ SuperFAP-E^{3S} Low Qg series

Low-on resistance, low switching noise and low switching loss

SuperFAP-E ^{3S} Low Qg series			TO-220	TO-220 (SLS)	TO-3P (Q)	TO-3PF	T-Pack(L)	T-Pack(S)	TFP
									
V _{DS} (V)	R _{DS(on)} (Ω)	I _D (A)							
500	0.5	12	✓	✓			✓	✓	✓
	0.38	16	✓	✓	✓		✓	✓	✓
	0.31	20	✓	✓	✓		✓	✓	✓
	0.27	21		✓	✓	✓			
	0.245	23		✓	✓	✓			
	0.19	28			✓	✓			
600	1.2	6	✓	✓			✓	✓	
	0.75	12	✓	✓			✓	✓	✓
	0.58	13	✓		✓		✓	✓	✓
	0.47	16	✓	✓	✓		✓	✓	✓
	0.4	17		✓	✓	✓			
	0.365	19		✓	✓	✓			
	0.28	23			✓	✓			

■ 500V class

Device type	V _{DSS} Volts	I _D Amps.	I _D (pulse) Amps.	R _{DS (on)} max. *1 Ohms	P _{tot} *2 Watts	V _{GS} Volts	V _{GS} (th) Volts	Q _G typ. nC	Package	Net mass Grams
FMP12N50ES	500	12	48	0.5	180	30	3.7±0.5	41	TO-220	2.0
FMV12N50ES	500	12	48	0.5	65	30	3.7±0.5	41	TO-220F(SLS)	1.7
FMI12N50ES	500	12	48	0.5	180	30	3.7±0.5	41	T-Pack(L)	1.6
FMC12N50ES	500	12	48	0.5	180	30	3.7±0.5	41	T-Pack(S)	1.6
FML12N50ES	500	12	48	0.5	180	30	3.7±0.5	41	TFP	1.6
FMP16N50ES	500	16	64	0.38	225	30	3.7±0.5	52	TO-220	2.0
FMV16N50ES	500	16	64	0.38	80	30	3.7±0.5	52	TO-220F(SLS)	1.7
FMI16N50ES	500	16	64	0.38	225	30	3.7±0.5	52	T-Pack(L)	1.6
FMC16N50ES	500	16	64	0.38	225	30	3.7±0.5	52	T-Pack(S)	1.6
FMH16N50ES	500	16	64	0.38	195	30	3.7±0.5	52	TO-3P(Q)	5.1
FML16N50ES	500	16	64	0.38	225	30	3.7±0.5	52	TFP	1.6
FMP20N50ES	500	20	80	0.31	270	30	4.2±0.5	57	TO-220	2.0
FMV20N50ES	500	20	80	0.31	95	30	4.2±0.5	57	TO-220F(SLS)	1.7
FMI20N50ES	500	20	80	0.31	270	30	4.2±0.5	57	T-Pack(L)	1.6
FMC20N50ES	500	20	80	0.31	270	30	4.2±0.5	57	T-Pack(S)	1.6
FMH20N50ES	500	20	80	0.31	235	30	4.2±0.5	57	TO-3P(Q)	5.1
FML20N50ES	500	20	80	0.31	270	30	4.2±0.5	57	TFP	1.6
FMV21N50ES	500	21	84	0.27	120	30	4.2±0.5	67	TO-220F(SLS)	1.7
FMR21N50ES	500	21	84	0.27	135	30	4.2±0.5	67	TO-3PF	6.0
FMH21N50ES	500	21	84	0.27	285	30	4.2±0.5	67	TO-3P(Q)	5.1
FMV23N50ES	500	23	92	0.245	130	30	4.2±0.5	74	TO-220F(SLS)	1.7
FMR23N50ES	500	23	92	0.245	150	30	4.2±0.5	74	TO-3PF	6.0
FMH23N50ES	500	23	92	0.245	315	30	4.2±0.5	74	TO-3P(Q)	5.1
FMR28N50ES	500	28	112	0.19	200	30	4.2±0.5	92	TO-3PF	6.0
FMH28N50ES	500	28	112	0.19	400	30	4.2±0.5	92	TO-3P(Q)	5.1

*1 R_{DS (on)} : V_{GS}=10V, *2 P_{tot}: T_C=25°C

The SuperFAP-E^{3S} series products satisfies the quality assurance level of general consumer use.

If you intend to use the products for equipment requiring higher reliability, such as equipment for automobiles and medical equipment, please contact Fuji Electric.

Do not use the products for equipment requiring strict reliability such as aerospace equipment.

SuperFAP-E^{3S} Low Qg series

600V class

Device type	V _{DSS}	I _D	I _{D (pulse)}	R _{DS(on)} max. *1	P _{tot} *2	V _{GS}	V _{GS(th)}	Q _G typ. nC	Package	Net mass
	Volts	Amps.	Amps.	Ohms	Watts	Volts	Volts			Grams
FMP06N60ES	600	6	24	1.2	105	30	3.7±0.5	31	TO-220	2.0
FMV06N60ES	600	6	24	1.2	37	30	3.7±0.5	31	TO-220F(SLS)	1.7
FMI06N60ES	600	6	24	1.2	105	30	3.7±0.5	31	T-Pack(L)	1.6
FMC06N60ES	600	6	24	1.2	105	30	3.7±0.5	31	T-Pack(S)	1.6
FMP12N60ES	600	12	48	0.75	180	30	4.2±0.5	37	TO-220	2.0
FMV12N60ES	600	12	48	0.75	65	30	4.2±0.5	37	TO-220F(SLS)	1.7
FMI12N60ES	600	12	48	0.75	180	30	4.2±0.5	37	T-Pack(L)	1.6
FMC12N60ES	600	12	48	0.75	180	30	4.2±0.5	37	T-Pack(S)	1.6
FML12N60ES	600	12	48	0.75	180	30	4.2±0.5	37	TFP	1.6
FMP13N60ES	600	13	48	0.58	225	30	4.2±0.5	48	TO-220	2.0
FMV13N60ES	600	13	48	0.58	225	30	4.2±0.5	48	TO-220F(SLS)	1.7
FMI13N60ES	600	13	48	0.58	225	30	4.2±0.5	48	T-Pack(L)	1.6
FMC13N60ES	600	13	48	0.58	225	30	4.2±0.5	48	T-Pack(S)	1.6
FMH13N60ES	600	13	48	0.58	195	30	4.2±0.5	48	TO-3P(Q)	5.1
FML13N60ES	600	13	48	1.58	225	30	4.2±0.5	48	TFP	1.6
FMP16N60ES	600	16	64	0.47	270	30	4.2±0.5	56	TO-220	2.0
FMV16N60ES	600	16	64	0.47	95	30	4.2±0.5	56	TO-220F(SLS)	1.7
FMI16N60ES	600	16	64	0.47	270	30	4.2±0.5	56	T-Pack(L)	1.6
FMC16N60ES	600	16	64	0.47	270	30	4.2±0.5	56	T-Pack(S)	1.6
FMH16N60ES	600	16	64	0.47	235	30	4.2±0.5	56	TO-3P(Q)	5.1
FML16N60ES	600	16	64	0.47	270	30	4.2±0.5	56	TFP	1.6
FMP17N60ES	600	17	68	0.4	120	30	4.2±0.5	68	TO-220F(SLS)	1.7
FMR17N60ES	600	17	68	0.4	135	30	4.2±0.5	68	TO-3PF	6.0
FMH17N60ES	600	17	68	0.4	285	30	4.2±0.5	68	TO-3P(Q)	5.1
FMP19N60ES	600	19	76	0.365	130	30	4.2±0.5	74	TO-220F(SLS)	1.7
FMR19N60ES	600	19	76	0.365	150	30	4.2±0.5	74	TO-3PF	6.0
FMH19N60ES	600	19	76	0.365	315	30	4.2±0.5	74	TO-3P(Q)	5.1
FMP23N60ES	600	23	92	0.28	200	30	4.2±0.5	92	TO-3PF	6.0
FMH23N60ES	600	23	92	0.28	400	30	4.2±0.5	92	TO-3P(Q)	5.1









*1 R_{DS(on)} : V_{GS}=10V, *2 P_{tot}: T_C=25°CThe SuperFAP-E^{3S} series products satisfies the quality assurance level of general consumer use.

If you intend to use the products for equipment requiring higher reliability, such as equipment for automobiles and medical equipment, please contact Fuji Electric.

Do not use the products for equipment requiring strict reliability such as aerospace equipment.

SuperFAP-G series

Low-on resistance and low gate charge

SuperFAP-G series			TO-220	TO-220F	TO-220 (SLS)	TO-3PF	TO-247	T-Pack(L)	T-Pack(S)	TFP
V_{DS} (V)	$R_{DS(on)}$ (Ω)	I_D (A)								
100	0.062	29	✓	✓				✓	✓	
120	0.03	67	✓	✓				✓	✓	✓
150	0.105	23	✓	✓				✓	✓	
	0.1	23								
	0.07	33	✓	✓				✓	✓	✓
	0.041	57	✓	✓				✓	✓	✓
200	0.016	100					✓			
	0.17	18	✓	✓				✓	✓	✓
	0.066	45	✓	✓				✓	✓	✓
	0.26	14	✓	✓				✓	✓	
250	0.13	24			✓					
	0.1	37	✓	✓		✓		✓	✓	✓
	0.053	59				✓	✓			
280	0.061	56			✓	✓				
300	0.28	15		✓						
	0.13	32	✓	✓				✓	✓	✓
450	2.5	3	✓	✓						
	1.6	4	✓	✓						
	0.65	10	✓	✓				✓	✓	
	0.38	17	✓	✓				✓	✓	✓
500	2.3	4	✓	✓				✓	✓	
	0.85	9	✓	✓				✓	✓	
	0.7	11	✓	✓				✓	✓	
	0.52	14	✓	✓				✓	✓	
	0.46	16	✓	✓				✓	✓	
	0.38	19	✓	✓				✓	✓	
	0.26	25				✓	✓	✓	✓	✓
	0.11	51					✓			
600	3.3	3	✓	✓				✓	✓	
	1.2	8	✓	✓				✓	✓	
	1	9	✓	✓				✓	✓	
	0.75	12	✓	✓				✓	✓	
	0.65	13	✓	✓		✓		✓	✓	
	0.57	16	✓	✓			✓	✓	✓	
	0.37	21				✓	✓			
700	0.6	17			✓					
900	8	2.2	✓	✓						
	6.4	2.6	✓	✓				✓	✓	
	4.3	3.7	✓	✓						
	2.5	6.0						✓	✓	

MOSFET

SuperFAP-G series

100 – 250V class

Device type	V_{DSS}	I_D	I_D (pulse)	$R_{DS(on)}$ max. *1	P_{tot} *2	V_{GS}	$V_{GS(th)}$	Q_G typ. nC	Package	Net mass
	Volts	Amps.	Amps.	Ohms	Watts	Volts	Volts			Grams
2SK3598-01	100	29	116	0.062	105	±30	3 to 5	22	TO-220	2.0
2SK3599-01MR	100	29	116	0.062	37	±30	3 to 5	22	TO-220F	1.7
2SK3600-01L, S	100	29	116	0.062	105	±30	3 to 5	22	T-pack	1.6
2SK3920-01	120	67	268	0.03	270	±30	3 to 5	52	TO-220	2.0
2SK3886-01MR	120	67	268	0.03	95	±30	3 to 5	52	TO-220F	1.7
2SK3921-01L, S	120	67	268	0.03	270	±30	3 to 5	52	T-pack	1.6
2SK3922-01	120	67	268	0.03	270	±30	3 to 5	52	TFP	0.8
2SK3602-01	150	23	92	0.105	105	±30	3 to 5	21	TO-220	2.0
2SK3603-01MR	150	23	92	0.105	37	±30	3 to 5	21	TO-220F	1.7
2SK3604-01L, S	150	23	92	0.105	105	±30	3 to 5	21	T-pack	1.6
2SK3648-01	150	33	132	0.07	150	±30	3 to 5	34	TO-220	2.0
2SK3649-01MR	150	33	132	0.07	53	±30	3 to 5	34	TO-220F	1.7
2SK3650-01L, S	150	33	132	0.07	150	±30	3 to 5	34	T-pack	1.6
2SK3474-01	150	33	132	0.07	150	±30	3 to 5	34	TFP	0.8
2SK3537-01MR	150	33	132	0.07	53	±20	1 to 2.5	46	TO-220F	1.7
2SK3590-01	150	57	228	0.041	270	±30	3 to 5	52	TO-220	2.0
2SK3591-01MR	150	57	228	0.041	95	±30	3 to 5	52	TO-220F	1.7
2SK3592-01L, S	150	57	228	0.041	270	±30	3 to 5	52	T-pack	1.6
2SK3593-01	150	57	228	0.041	270	±30	3 to 5	52	TFP	0.8
2SK3882-01	150	100	400	0.016	600	±30	3 to 5	140	TO-247	4.9
2SK3606-01	200	18	72	0.17	105	±30	3 to 5	21	TO-220	2.0
2SK3607-01MR	200	18	72	0.17	37	±30	3 to 5	21	TO-220F	1.7
2SK3608-01L, S	200	18	72	0.17	105	±30	3 to 5	21	T-pack	1.6
2SK3609-01	200	18	72	0.17	105	±30	3 to 5	21	TFP	0.8
2SK3594-01	200	45	180	0.066	270	±30	3 to 5	51	TO-220	2.0
2SK3595-01MR	200	45	180	0.066	95	±30	3 to 5	51	TO-220F	1.7
2SK3596-01L, S	200	45	180	0.066	270	±30	3 to 5	51	T-pack	1.6
2SK3597-01	200	45	180	0.066	270	±30	3 to 5	51	TFP	0.8
2SK3610-01	250	14	56	0.26	105	±30	3 to 5	21	TO-220	2.0
2SK3611-01MR	250	14	56	0.26	37	±30	3 to 5	21	TO-220F	1.7
2SK3612-01L, S	250	14	56	0.26	105	±30	3 to 5	21	T-pack	1.6
FMV24N25G	250	24	96	0.13	65	±30	3 to 5	36	TO-220F(SLS)	1.7
2SK3554-01	250	37	148	0.1	270	±30	3 to 5	44	TO-220	2.0
2SK3555-01MR	250	37	148	0.1	95	±30	3 to 5	44	TO-220F	1.7
2SK3556-01L, S	250	37	148	0.1	270	±30	3 to 5	44	T-pack	1.6
2SK3535-01	250	37	148	0.1	270	±30	3 to 5	44	TFP	0.8
2SK3651-01R	250	37	148	0.1	115	±30	3 to 5	44	TO-3PF	6.0
2SK3778-01	250	59	236	0.053	410	±30	3 to 5	80	TO-247	4.9
2SK3779-01R	250	59	236	0.053	210	±30	3 to 5	80	TO-3PF	6.0

*1 $R_{DS(on)}$: $V_{GS}=10V$, *2 P_{tot} : $T_C=25^\circ C$

The Super FAP-G series products satisfies the quality assurance level of general consumer use.

If you intend to use the products for equipment requiring higher reliability, such as equipment for automobiles and medical equipment, please contact Fuji Electric.

Do not use the products for equipment requiring strict reliability such as aerospace equipment.

SuperFAP-G series

300 – 500V class

Device type	V _{DSS}	I _D	I _D (pulse)	R _{DS(on)} max. *1	P _{tot} *2	V _{GS}	V _{GS(th)}	Q _G typ. nC	Package	Net mass Grams
	Volts	Amps.	Amps.	Ohms	Watts	Volts	Volts			
2SK3580-01MR	300	15	60	0.28	48	±30	3.5 to 4.5	23	TO-220F	1.7
2SK3772-01	300	32	128	0.13	270	±30	3 to 5	44.5	TO-220	2.0
2SK3773-01MR	300	32	128	0.13	95	±30	3 to 5	44.5	TO-220F	1.7
2SK3774-01L, S	300	32	128	0.13	270	±30	3 to 5	44.5	T-pack	1.6
2SK3775-01	300	32	128	0.13	270	±30	3 to 5	44.5	TFP	0.8
2SK3725-01	450	3	12	2.5	50	±30	3 to 5	10.5	TO-220	2.0
2SK3726-01MR	450	3	12	2.5	17	±30	3 to 5	10.5	TO-220F	1.7
2SK3916-01	450	4.3	17.2	1.6	21	±30	3 to 5	13	TO-220	2.0
2SK3917-01MR	450	4.3	17.2	1.6	21	±30	3 to 5	13	TO-220F	1.7
2SK3514-01	450	10	40	0.65	135	±30	3 to 5	22	TO-220	2.0
2SK3515-01MR	450	10	40	0.65	48	±30	3 to 5	22	TO-220F	1.7
2SK3516-01L, S	450	10	40	0.65	135	±30	3 to 5	22	T-pack	1.6
2SK3692-01	450	17	68	0.38	225	±30	3 to 5	33	TO-220	2.0
2SK3693-01MR	450	17	68	0.38	80	±30	3 to 5	33	TO-220F	1.7
2SK3694-01L, S	450	17	68	0.38	225	±30	3 to 5	33	T-pack	1.6
2SK4040-01	450	17	68	0.38	225	±30	3 to 5	33	TFP	0.8
2SK3985-01	500	3.6	14.4	2.3	60	±30	3 to 5	13	TO-220	2.0
2SK3986-01MR	500	3.6	14.4	2.3	21	±30	3 to 5	13	TO-220F	1.7
2SK3987-01L, S	500	3.6	14.4	2.3	60	±30	3 to 5	13	T-pack	1.6
2SK3519-01	500	9	36	0.85	135	±30	3 to 5	20	TO-220	2.0
2SK3520-01MR	500	9	36	0.85	48	±30	3 to 5	20	TO-220F	1.7
2SK4004-01MR	500	9	36	0.85	48	±30	2.5 to 3.5	24	TO-220F	1.7
2SK3521-01L, S	500	9	36	0.85	135	±30	3 to 5	20	T-pack	1.6
2SK3931-01	500	11	44	0.70	165	±30	3 to 5	25	TO-220	2.0
2SK3932-01MR	500	11	44	0.70	60	±30	3 to 5	25	TO-220F	1.7
2SK3933-01L, S	500	11	44	0.70	165	±30	3 to 5	25	T-pack	1.6
2SK3468-01	500	14	56	0.52	195	±30	3 to 5	30	TO-220	2.0
2SK3469-01MR	500	14	56	0.52	70	±30	3 to 5	30	TO-220F	1.7
2SK3512-01L, S	500	14	56	0.52	195	±30	3 to 5	30	T-pack	1.6
2SK3504-01	500	16	64	0.46	225	±30	3 to 5	33	TO-220	2.0
2SK3505-01MR	500	16	64	0.46	80	±30	3 to 5	33	TO-220F	1.7
2SK3581-01L, S	500	16	64	0.46	225	±30	3 to 5	33	T-pack	1.6
2SK3682-01	500	19	76	0.38	270	±30	3 to 5	32	TO-220	2.0
2SK3683-01MR	500	19	76	0.38	95	±30	3 to 5	32	TO-220F	1.7
2SK3684-01L, S	500	19	76	0.38	270	±30	3 to 5	32	T-pack	1.6
2SK3685-01	500	19	76	0.38	235	±30	3 to 5	32	TO-247	4.9
FML19N50G	500	19	76	0.38	270	±30	3 to 5	32	TFP	0.8
2SK3522-01	500	25	100	0.26	335	±30	3 to 5	54	TO-247	4.9
2SK3523-01R	500	25	100	0.26	160	±30	3 to 5	54	TO-3PF	6.0
2SK3680-01	500	51	208	0.11	600	±30	3 to 5	118	TO-247	4.9

*1 R_{DS(on)} : V_{GS}=10V, *2 P_{tot}: T_C=25°C





SuperFAP-G series

600 – 900V class

Device type	V_{DSS}	I_D	I_D (pulse)	$R_{DS(on)}$ max. *1	P_{tot} *2	V_{GS}	$V_{GS(th)}$	Q_G typ. nC	Package	Net mass
	Volts	Amps.	Amps.	Ohms	Watts	Volts	Volts			Grams
2SK3988-01	600	3	12	3.3	60	±30	3 to 5	13	TO-220	2.0
2SK3989-01MR	600	3	12	3.3	21	±30	3 to 5	13	TO-220F	1.7
2SK3990-01L, S	600	3	12	3.3	60	±30	3 to 5	13	T-pack	1.6
2SK3524-01	600	8	32	1.2	135	±30	3 to 5	20	TO-220	2.0
2SK3525-01MR	600	8	32	1.2	48	±30	3 to 5	20	TO-220F	1.7
2SK3526-01L, S	600	8	32	1.2	135	±30	3 to 5	20	T-pack	1.6
2SK3887-01	600	9	36	1.0	165	±30	3 to 5	25	TO-220	2.0
2SK3888-01MR	600	9	36	1.0	60	±30	3 to 5	25	TO-220F	1.7
2SK3889-01L, S	600	9	36	1.0	165	±30	3 to 5	25	T-pack	1.6
2SK3501-01	600	12	48	0.75	195	±30	3 to 5	30	TO-220	2.0
2SK3502-01MR	600	12	48	0.75	70	±30	3 to 5	30	TO-220F	1.7
2SK3513-01L, S	600	12	48	0.75	195	±30	3 to 5	30	T-pack	1.6
2SK3450-01	600	13	52	0.65	225	±30	3 to 5	34	TO-220	2.0
2SK3451-01MR	600	13	52	0.65	80	±30	3 to 5	34	TO-220F	1.7
2SK3753-01R	600	13	52	0.65	95	±30	3 to 5	34	TO-3PF	6.0
2SK3686-01	600	16	64	0.57	270	±30	3 to 5	33	TO-220	2.0
2SK3687-01MR	600	16	64	0.57	97	±30	3 to 5	33	TO-220F	1.7
2SK3688-01L, S	600	16	64	0.57	270	±30	3 to 5	33	T-pack	1.6
2SK3689-01	600	16	64	0.57	235	±30	3 to 5	33	TO-247	4.9
2SK3527-01	600	21	84	0.37	335	±30	3 to 5	54	TO-247	4.9
2SK3528-01R	600	21	84	0.37	160	±30	3 to 5	54	TO-3PF	6.0
2SK3681-01	600	43	172	0.16	600	±30	3 to 5	118	TO-247	4.9
2SK3891-01R	700	17	68	0.6	170	±30	3 to 5	46	TO-3PF	6.0
2SK3727-01	900	2.2	8.8	8.0	75	±30	3.5 to 4.5	8.3	TO-220	2.0
2SK3728-01MR	900	2.2	8.8	8.0	26	±30	3.5 to 4.5	8	TO-220F	1.7
2SK3981-01	900	2.6	10.4	6.4	90	±30	3 to 5	13	TO-220	2.0
2SK3982-01MR	900	2.6	10.4	6.4	32	±30	3 to 5	13	TO-220F	1.7
2SK3983-01L, S	900	2.6	10.4	6.4	90	±30	3 to 5	13	T-pack	1.6
2SK3698-01	900	3.7	14.8	4.3	120	±30	3.5 to 4.5	13	TO-220	2.0
2SK3699-01MR	900	3.7	14.8	4.3	43	±30	3.5 to 4.5	13	TO-220F	1.7
2SK3676-01L, S	900	6	24	2.5	195	±30	3 to 5	21.5	T-pack	1.6

*1 $R_{DS(on)}$: $V_{GS}=10V$, *2 P_{tot} : $T_C=25^\circ C$

■ SuperFAP-G Built-in FRED series

SuperFAP-G Built-in FRED series			TO-220	TO-220F	TO-247	T-Pack (L)	T-Pack (S)
							
V_{DS} (V)	$R_{DS(on)}$ (Ω)	I_D (A)					
500	0.55	13	✓	✓			
600	0.8	11	✓	✓		✓	✓
	0.17	42			✓		







■ 500 – 600V class

Device type	V_{DSS}	I_D	I_D (pulse)	$R_{DS(on)}$ max. ^{*1}	P_{tot} ^{*2}	V_{GS}	$V_{GS(th)}$	Q_G typ. nC	Package	Net mass
	Volts	Amps.	Amps.	Ohms	Watts	Volts	Volts			Grams
2SK3695-01	500	13	52	0.55	195	±30	3 to 5	28	TO-220	2.0
2SK3696-01MR	500	13	52	0.55	70	±30	3 to 5	28	TO-220F	1.7
2SK3928-01	600	11	44	0.8	195	±30	3 to 5	30	TO-220	2.0
2SK3929-01MR	600	11	44	0.8	70	±30	3 to 5	30	TO-220F	1.7
2SK3930-01L, S	600	11	44	0.8	195	±30	3 to 5	30	T-pack	1.6
2SK3697-01	600	42	168	0.17	600	±30	3 to 5	105	TO-247	4.9

*1 $R_{DS(on)}$: $V_{GS}=10V$, *2 P_{tot} : $T_C=25^\circ C$

Trench Power MOSFET

Low-on resistance and high gate capability

Trench Power MOSFET			TO-220	TO-220F	TO-3P (Q)	TO-247	T-Pack(L)	T-Pack(S)	D2-pack
V_{DS} (V)	$R_{DS(on)}$ (Ω)	I_D (A)							
40	0.060	70				✓			
60	0.0065	70		✓					
		80	✓				✓	✓	✓
75	0.0079	70		✓					
		80						✓	
100	0.0067	80						✓	
		100				✓			
		80	✓	✓			✓	✓	
150	0.0245	65	✓	✓			✓	✓	
200	0.0470	49	✓	✓			✓	✓	

60 – 100V class

Device type	V_{DSS} Volts	I_D Amps.	I_D (pulse) Amps.	$R_{DS(on)}$ max. *1 Ohms	P_{tot} *2 Watts	V_{GS} Volts	$V_{GS(th)}$ typ. Volts	Package	Net mass Grams
2SK4068-01	40	70	280	0.006	115	+30/-20	3.0	TO-247	4.9
2SK3273-01MR	60	70	280	0.0065	70	+30/-20	3.0	TO-220F	1.7
2SK3270-01	60	80	320	0.0065	135	+30/-20	3.0	TO-220	2.0
2SK3272-01L, S	60	80	320	0.0065	135	+30/-20	3.0	T-pack (L, S)	1.6
2SK3272-01SJ	60	80	320	0.0065	135	+30/-20	3.0	D2-pack	1.6
2SK4047-01S	60	80	320	0.0065	195	+30/-20	3.0	T-pack (S)	1.6
2SK3271-01	60	100	400	0.0065	155	+30/-20	3.0	TO-3P	5.5
2SK3730-01MR	75	70	280	0.0079	70	± 20	3.0	TO-220F	1.7
2SK3804-01S	75	70	280	0.0085	162	± 20	3.0	T-pack (S)	1.6
FMC80N10R6	100	80	320	0.0067	180	+30/-20	3.0	T-pack (S)	1.6
FMY100N10R6	100	100	400	0.0067	280	+30/-20	3.0	TO-247	6.3

*1 $R_{DS(on)}$: $V_{GS}=10V$, *2 P_{tot} : $T_C=25^\circ C$

100 – 200V class

Device type	V_{DSS} Volts	I_D Amps.	I_D (pulse) Amps.	$R_{DS(on)}$ max. *1 Ohms	P_{tot} *2 Watts	V_{GS} Volts	$V_{GS(th)}$ typ. Volts	Package	Net mass Grams
FMP80N10T2	100	80	320	0.0128	270	+30/-20	2 to 4	TO-220	2.0
FMA80N10T2	100	80	320	0.0128	95	+30/-20	2 to 4	TO-220F	1.7
FMI80N10T2	100	80	320	0.0128	270	+30/-20	2 to 4	T-pack(L)	1.6
FMC80N10T2	100	80	320	0.0128	270	+30/-20	2 to 4	T-pack(S)	1.6
FMP65N15T2	150	65	260	0.0245	270	+30/-20	2 to 4	TO-220	2.0
FMA65N15T2	150	65	260	0.0245	95	+30/-20	2 to 4	TO-220F	1.7
FMI65N15T2	150	65	260	0.0245	270	+30/-20	2 to 4	T-pack(L)	1.6
FMC65N15T2	150	65	260	0.0245	270	+30/-20	2 to 4	T-pack(S)	1.6
FMP49N20T2	200	49	196	0.047	270	+30/-20	2 to 4	TO-220	2.0
FMA49N20T2	200	49	196	0.047	95	+30/-20	2 to 4	TO-220F	1.7
FMI49N20T2	200	49	196	0.047	270	+30/-20	2 to 4	T-pack(L)	1.6
FMC49N20T2	200	49	196	0.047	270	+30/-20	2 to 4	T-pack(S)	1.6

*1 $R_{DS(on)}$: $V_{GS}=10V$, *2 P_{tot} : $T_C=25^\circ C$



The Trench Power MOSFET series products satisfies the quality assurance level of general consumer use.

If you intend to use the products for equipment requiring higher reliability, such as equipment for automobiles and medical equipment, please contact Fuji Electric. Do not use the products for equipment requiring strict reliability such as aerospace equipment.

Automotive Super J MOS[®] S1 series



Low-on resistance, low switching noise and low switching loss

Automotive Super J MOS [®] S1 Series			TO-247	T-Pack(S)
V_{DS} (V)	$R_{DS(on)}$ (Ω)	I_D (A)		
600	0.145	29	✓	✓
	0.082	46	✓	
	0.070	47	✓	
	0.071	52	✓	
	0.062	53	✓	
	0.046	67	✓	
650	0.040	68	✓	
	0.071	52	✓	

600V class

Device type	V_{DSS} Volts	I_D Amps.	I_D (pulse) Amps.	$R_{DS(on)}$ max. Ohms *1	P_{tot} *2 Watts	V_{GS} Volts	$V_{GS(th)}$ typ. Volts	Q_G typ. nC	Package	Net mass Grams
FMY47N60S1A	600	47	141	0.070	390	30	3.0±0.5	125	TO-247	6.4
FMY53N60S1A	600	53	159	0.062	480	30	3.0±0.5	164	TO-247	6.4
FMY68N60S1A	600	68	204	0.040	545	30	3.0±0.5	203	TO-247	6.4

*1 $R_{DS(on)}$: $V_{GS}=10V$, *2 P_{tot} : $T_C=25^\circ C$

Super J MOS[®] is registered trademarks of Fuji Electric.

The Automotive Super J MOS[®] S1 series of products satisfies the quality assurance level of general automobile use (conforms to AEC-Q101). Do not use the products for equipment requiring strict reliability such as aerospace equipment.

Automotive Super J MOS[®] S1FD series (Built-in FRED type)



600V, 650V class

Device type	V_{DSS} Volts	I_D Amps.	I_D (pulse) Amps.	$R_{DS(on)}$ max. Ohms *1	P_{tot} *2 Watts	V_{GS} Volts	$V_{GS(th)}$ typ. Volts	Q_G typ. nC	t_{rr} typ. nsec	Package	Net mass Grams
FMC29N60S1FDA	600	29	87	0.145	220	30	4.0±1	75	170	T-Pack	1.6
FMY29N60S1FDA	600	29	87	0.145	220	30	4.0±1	75	170	TO-247	6.4
FMY46N60S1FDA	600	46	138	0.082	390	30	4.0±1	130	210	TO-247	6.4
FMY52N60S1FDA	600	52	156	0.071	480	30	4.0±1	165	280	TO-247	6.4
FMY67N60S1FDA	600	67	201	0.046	545	30	4.0±1	220	280	TO-247	6.4
FMY52N65S1FDA	650	52	156	0.071	480	30	4.0±1	165	280	TO-247	6.4

*1 $R_{DS(on)}$: $V_{GS}=10V$, *2 P_{tot} : $T_C=25^\circ C$

Super J MOS[®] is registered trademarks of Fuji Electric.



The Automotive Super J MOS[®] S1FD series of products satisfies the quality assurance level of general automobile use (conforms to AEC-Q101). Do not use the products for equipment requiring strict reliability such as aerospace equipment.

MOSFET

Automotive Super J MOS[®] S2 series



Low-on resistance, low switching noise and low switching loss

Automotive Super J MOS [®] S2 Series			TO-247	T-Pack(S)
V_{DS} (V)	$R_{DS(on)}$ (Ω)	I_D (A)		
400	0.060	42		✓
500	0.071	38.9	✓	✓
600	0.160	17.9	✓	✓
	0.133	22.8	✓	✓
	0.125	22.8	✓	✓
	0.105	29.3	✓	✓
	0.099	29.3	✓	✓
	0.088	32.8	✓	✓
	0.081	37.1	✓	✓
	0.079	37.1	✓	✓
	0.070	39.4	✓	
	0.040	66.2	✓	
0.025	95.5	✓		

600V class

Device type	V_{DSS} Volts	I_D Amps.	I_D (pulse) Amps.	$R_{DS(on)}$ max. *1 Ohms	P_{tot} *2 Watts	V_{GS} Volts	$V_{GS(th)}$ typ. Volts	Q_G typ. nC	Package	Net mass Grams
FMY60N160S2A	600	17.9	53.7	0.160	110	30	4.0±0.5	43	TO-247	6.4
FMC60N160S2A	600	17.9	53.7	0.160	127	30	4.0±0.5	43	T-Pack	1.6
FMY60N125S2A	600	22.8	68.2	0.125	140	30	4.0±0.5	53	TO-247	6.4
FMC60N125S2A	600	22.8	68.2	0.125	160	30	4.0±0.5	53	T-Pack	1.6
FMY60N099S2A	600	29.3	87.7	0.099	185	30	4.0±0.5	65	TO-247	6.4
FMC60N099S2A	600	29.3	87.7	0.099	210	30	4.0±0.5	65	T-Pack	1.6
FMY60N088S2A	600	32.8	98.4	0.088	205	30	4.0±0.5	72	TO-247	6.4
FMC60N088S2A	600	32.8	98.4	0.088	235	30	4.0±0.5	72	T-Pack	1.6
FMY60N079S2A	600	37.1	111.3	0.079	235	30	4.0±0.5	80	TO-247	6.4
FMC60N079S2A	600	37.1	111.3	0.079	270	30	4.0±0.5	80	T-Pack	1.6
FMY60N070S2A	600	39.4	118.2	0.070	270	30	4.0±0.5	90	TO-247	6.4
FMY60N040S2A	600	66.2	198.6	0.040	435	30	4.0±0.5	147	TO-247	6.4
FMY60N025S2A	600	95.5	286.5	0.025	575	30	4.0±0.5	222	TO-247	6.4

*1 $R_{DS(on)}$: $V_{GS}=10V$, *2 P_{tot} : $T_C=25^\circ C$

Super J MOS[®] is registered trademarks of Fuji Electric.

The Automotive Super J MOS[®] S1FD series of products satisfies the quality assurance level of general automobile use (conforms to AEC-Q101). Do not use the products for equipment requiring strict reliability such as aerospace equipment.

Automotive Super J MOS[®] S2FD series (Built-in FRED type)



400V, 500V class

Device type	V_{DS}	I_D	I_D (pulse)	$R_{DS(on)}$ max. *1	P_{tot} *2	V_{GS}	$V_{GS(th)}$ typ.	Q_G typ.	Package	Net mass Grams
	Volts	Amps.	Amps.	Ohms	Watts	Volts	Volts	nC		
FMC40N060S2FDA	400	42	126	0.060	270	30	4.0±1	120	T-Pack	1.6
FMY50N071S2FDA	500	38.9	116.7	0.071	235	30	4.0±1	98	TO-247	6.4
FMC50N071S2FDA	500	38.9	116.7	0.071	270	30	4.0±1	98	T-Pack	1.6

600V class

Device type	V_{DS}	I_D	I_D (pulse)	$R_{DS(on)}$ max. *1	P_{tot} *2	V_{GS}	$V_{GS(th)}$ typ.	Q_G typ.	Package	Net mass Grams
	Volts	Amps.	Amps.	Ohms	Watts	Volts	Volts	nC		
FMY60N133S2FDA	600	22.8	68.2	0.133	140	30	4.0±1	59	TO-247	6.4
FMC60N133S2FDA	600	22.8	68.2	0.133	160	30	4.0±1	59	T-Pack	1.6
FMY60N105S2FDA	600	29.3	87.7	0.105	185	30	4.0±1	75	TO-247	6.4
FMC60N105S2FDA	600	29.3	87.7	0.105	210	30	4.0±1	75	T-Pack	1.6
FMY60N081S2FDA	600	37.1	111.3	0.081	235	30	4.0±1	93	TO-247	6.4
FMC60N081S2FDA	600	37.1	111.3	0.081	270	30	4.0±1	93	T-Pack	1.6

*1 $R_{DS(on)}$: $V_{GS}=10V$, *2 P_{tot} : $T_C=25^{\circ}C$

Super J MOS[®] is registered trademarks of Fuji Electric.

The Automotive Super J MOS[®] S2FD series of products satisfies the quality assurance level of general automobile use (conforms to AEC-Q101). Do not use the products for equipment requiring strict reliability such as aerospace equipment.

Automotive MOSFET (Trench Power MOS, SuperFAP-E^{3S})

Automotive Trench Power MOSFET SuperFAP-E ^{3S} Low Qg series			TO-220	TO-220F	TO-3P (Q)	TO-247	T-Pack(L)	T-Pack(S)	D2-pack
V_{DS} (V)	$R_{DS(on)}$ (Ω)	I_D (A)							
40	0.006	70				✓			
60	0.0065	70		✓					
		80	✓			✓	✓	✓	✓
75	0.0065	100			✓	✓			
	0.0079	70		✓				✓	
100	0.0085	70						✓	
	0.0067	80					✓		
	0.0128	80							
150	0.0067	100				✓			
	0.0245	65							
200	0.047	49							
300	0.085	47				✓			
	0.072	50				✓			
	0.053	67				✓			
	0.045	72				✓			
600	0.29	22				✓			
	0.28	24				✓			
	0.21	30				✓			
	0.20	31				✓			
	0.17	35				✓			
	0.16	36				✓			

MOSFET

Automotive SuperFAP-E^{3S} Low Qg series



300 – 600V class

Device type	V _{DSS}	I _D	I _D (pulse)	R _{DS(on)} max. *1	P _{tot} *2	V _{GS}	V _{GS(th)} typ.	Q _G typ.	Package	Net mass
	Volts	Amps.	Amps.	Ohms	Watts	Volts	Volts	nC		Grams
FMY50N30ES	300	50	200	0.072	400	+30/-30	4.2±0.5	97	TO-247	6.4
FMY72N30ES	300	72	288	0.045	570	+30/-30	4.2±0.5	155	TO-247	6.4
FMY24N60ES	600	24	96	0.280	400	+30/-30	4.2±0.5	95	TO-247	6.4
FMY31N60ES	600	31	124	0.200	495	+30/-30	4.2±0.5	125	TO-247	6.4
FMY36N60ES	600	36	144	0.160	570	+30/-30	4.2±0.5	155	TO-247	6.4

*1 R_{DS(on)}: V_{GS}=10V, *2 P_{tot}: T_C=25°C

The Automotive SuperFAP-E^{3S} Low Qg series of products satisfies the quality assurance level of general automobile use (conforms to AEC-Q101). Do not use the products for equipment requiring strict reliability such as aerospace equipment.

Automotive SuperFAP-E^{3S} Low Qg Built-in FRED series



Low-on resistance, low switching noise and low switching loss

300 – 600V class

Device type	V _{DSS}	I _D	I _D (pulse)	R _{DS(on)} max. *1	P _{tot} *2	V _{GS}	V _{GS(th)} typ.	Q _G typ.	t _{rr} typ.	Package	Net mass
	Volts	Amps.	Amps.	Ohms	Watts	Volts	Volts	nC	nsec		Grams
FMY47N30ESF	300	47	188	0.085	400	+30/-30	4.2±1.0	96	130	TO-247	6.4
FMY67N30ESF	300	67	268	0.053	570	+30/-30	4.2±1.0	155	150	TO-247	6.4
FMY22N60ESF	600	22	88	0.290	400	+30/-30	4.2±1.0	95	150	TO-247	6.4
FMY30N60ESF	600	30	120	0.210	495	+30/-30	4.2±1.0	125	160	TO-247	6.4
FMY35N60ESF	600	35	140	0.170	570	+30/-30	4.2±1.0	155	160	TO-247	6.4

*1 R_{DS(on)}: V_{GS}=10V, *2 P_{tot}: T_C=25°C

Automotive SuperFAP-E^{3S} Low Qg Built-in FRED series of products satisfies the quality assurance level of general automobile use (conforms to AEC-Q101). Do not use the products for equipment requiring strict reliability such as aerospace equipment.

Automotive Trench Power MOSFET

40 – 100V class

Device type	V _{DSS}	I _D	I _D (pulse)	R _{DS(on)} max. *1	P _{tot} *2	V _{GS}	V _{GS(th)} typ.	Package	Net mass
	Volts	Amps.	Amps.	Ohms	Watts	Volts	Volts		Grams
2SK4068-01	40	70	280	0.006	115	+30/-20	3.0	TO-247	4.9
2SK3273-01MR	60	70	280	0.0065	70	+30/-20	3.0	TO-220F	1.7
2SK3270-01	60	80	320	0.0065	135	+30/-20	3.0	TO-220	2.0
2SK3272-01L, S	60	80	320	0.0065	135	+30/-20	3.0	T-pack	1.6
2SK3272-01SJ	60	80	320	0.0065	135	+30/-20	3.0	D2-pack	1.6
2SK4047-01S	60	80	320	0.0065	195	+30/-20	3.0	T-pack	1.6
FMY100N06T *3	60	100	400	0.0065	135	+30/-20	3.0	TO-247	6.3
2SK3271-01	60	100	400	0.0065	155	+30/-20	3.0	TO-3P	5.5
2SK3730-01MR	75	70	280	0.0079	70	±20	3.0	TO-220F	1.7
2SK3804-01S	75	70	280	0.0085	135	±20	3.0	T-pack	1.6
FMC80N10R6	100	80	320	0.0067	324	+30/-20	3.0	T-Pack	1.6
FMY100N10R6 *3	100	100	400	0.0067	280	+30/-20	3.0	TO-247	6.3

*1 R_{DS(on)}: V_{GS}=10V, *2 P_{tot}: T_C=25°C

*3 FMY100N06T and FMY100N10R6 satisfies the quality assurance level of general automobile use (conforms to AEC-Q101). Do not use the products for equipment requiring strict reliability such as aerospace equipment.

Automotive IPS series (Intelligent Power Switches)

Self protection

Device type	Type	Channels	V_{CC} DC (pulse) Volts	I_D Amps.	$R_{DS(on)}$ typ. Ohms	$R_{DS(on)}$ max. Ohms	P_{tot} Watts	Package	Net mass Grams	Remarks
F5044H	High side	1	33 (50)	2.5	0.09 * ¹	0.12 * ¹	1.5	SOP-8	0.2	
F5045P	High side	1	33 (50)	1	0.37 * ¹	0.60 * ¹	1.5	SOP-8	0.2	
F5106H	High side	1	35 (50)	2	0.1 * ¹	0.12 * ¹	1.5	SOP-8	0.2	Built-in Amp
F5112H	High side	1	35 (50)	2	0.1 * ¹	0.12 * ¹	2	SOP-8	0.2	Low stand by current version for F5044H
F5062H	High side	1	35 (50)	50	0.006 * ¹	0.008 * ¹	114	PSOP-12	0.4	
F5074H	High side	1	35 (50)	80	0.004 * ¹	0.005 * ¹	114	PSOP-12	0.4	
F5018	Low side	1	40	8	0.088 * ²	0.14 * ²	15	K-pack	0.6	
F5019	Low side	1	40	12	0.088 * ²	0.14 * ²	30	T-pack	1.6	
F5020	Low side	1	40	3	0.25 * ²	0.40 * ²	10	K-pack	0.6	
F5033	Low side	2	40	1	0.41 * ²	0.60 * ²	1.5	SOP-8	0.2	
F5041	Low side	2	40	1	0.47 * ²	0.60 * ²	1.5	SOP-8	0.2	
F5042	Low side	1	40	8	0.088 * ²	0.14 * ²	15	K-pack	0.6	High frequency switching version for F5018
F5043	Low side	1	40	12	0.088 * ²	0.14 * ²	30	T-pack	1.6	High frequency switching version for F5019
F5048	Low side	1	80	15	0.091 * ²	0.125 * ²	43	T-pack	1.6	
F5055	Low side	2	40	5.9	0.088 * ²	0.14 * ²	7.8	SSOP-20	0.3	
F5063L	Low side	2	40	1.9	0.095 * ²	0.14 * ²	1.75	SOP-8	0.2	

*¹ $R_{DS(on)}$: $V_{CC}=13V$, *² $R_{DS(on)}$: $V_{IN}/V_{GS}=5V$

Rectifier Diodes



Fuji Electric's rectifier diodes have features such as low V_f characteristics and low I_R , and are compatible with PFC circuits of power supplies and secondary-side rectification circuits.

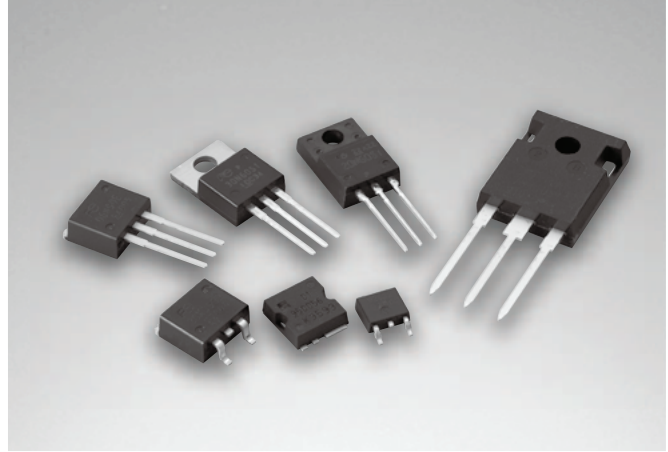

Features of SBD, LLD

Ultra Low-IR SBD (Schottky-Barrier Diode)

■ Features

- Guaranteed $T_{vj}=175^{\circ}\text{C}$
- V_f is same level and I_R is reduced by less than 1/10.

LLD (Low Loss Diode) Super LLD series for PFC circuit

■ Features

Super LLD-3 for CCM-PFC

- Realize acceleration and low V_f compared with existing model.

Super LLD-2 for CRM-PFC

- Achieved low power loss by low V_f
- Achieved low noise by soft recovery

■ Part numbers

FDRW50C60L (example)

F	DR		W		50	C		60		L	
Company code	Device code		Package code		Current	Polarity		Voltage		Series	
Fuji	DR	FWD	P	TO-220	× 1	S,T	Single	60	600V	L	Ultra Fast Recovery
			W	TO-247-P2		C	Cathode Common	65	650V		
								120	1200V	J	Sort/Fast Recovery

■ Part numbers

YA875C10R (example)





YA		87		5		C		10				R		
Package code		Series		Current		Polarity		Voltage				Additional code		
KP	K-Pack (L)	8x	SBD	1	5A	S	Single	SBD	02	20V	LLD	2	200V	R or RR
KS	K-Pack (S)	9x	LLD	2	10A	C	Cathode Common		03	30V		3	300V	
MS	TFP			3	15A				04	40V		4	400V	
PA	TO-3P			4	15A	06	60V		6	600V				
PG	TO-3PF			5	20A	08	80V		8	800V				
PH	TO-247			6	30A	09	90V		10	1000V				
TP	T-Pack (L)			8	30A	10	100V		12	1200V				
TS	T-Pack (S)			9	40A	12	120V		15	1500V				
YA	TO-220			0	40A	15	150V							
YG	TO-220F					20	200V							

■ Part numbers

ESAD92M02R (example)

ESA		D		92		M		02				R			
Chip		Current		Series		Package code		Voltage				Additional code			
ESA	Dual chips	Lead	ERA	≤ 1A	8x	SBD	non	Non Isolation	SBD	004	40V	LLD	02	200V	R or RR
ER	Single chip		ERB	≤ 2A	9x	LLD	M	Full mold		006	60V		03	300V	
			ERC	≤ 3A						009	90V				
			ERD	-											
			ERC	≤ 5A											
		TOPKG	ESAB	5A-10A											
			ESAC	10A-20A											
			ESAD	20A-30A											

Schottky-Barrier Diodes(SBD)

Schottky-Barrier Diodes(SBD)					TO-220F	K-Pack(L)	K-Pack(S)	TFP
								
Chip	V _{RRM} (V)	I _O (A)	V _F (V)	I _R (mA)				
Single	40	5	0.55	5	✓		✓	
	45	10	0.60	2	✓			
	60	5	0.59	5	✓			
		15	0.63	20	✓			
Dual	20	7	0.39	10		✓	✓	
	30	5	0.47	5			✓	
	40	5	0.55	5	✓		✓	
		10	0.55	5	✓			
		20	0.6	15	✓			
		30	0.53	8	✓			✓
	60	5	0.58	5	✓			
		10	0.58	5	✓			
		15	0.58	5	✓			
		20	0.58	15	✓			
		30	0.58	3	✓			✓
	90	5	0.9	5			✓	
	100	5	0.8	0.7	✓			
10		0.8	1.2	✓				
20		0.8	2.5	✓				
30		0.8	20	✓				

1 in one-package

Device type	Maximum rating			Thermal rating T _{vj} and T _{stg} °C	Characteristics (T _a =25°C)			Package	Net mass Grams
	V _{RRM} Volts	I _O *1 Amps.	I _{FSM} *2 Amps.		V _{FM} max. Volts	I _{RRM} *3 max.mA	R _{th(j-c)} °C/W		
KS826S04	40	5.0 (T _C =110°C)	80	-40 to +150	0.55 (I _F =5.0A)	5	10	K-pack(S)	0.6
YG811S04R	40	5.0 (T _C =122°C)	120	-40 to +150	0.55 (I _F =5.0A)	5	5.0	TO-220F	1.7
YG812S04R	45	10 (T _C =124°C)	120	-40 to +150	0.6 (I _F =10A)	2	2.5	TO-220F	1.7
YG811S06R	60	5.0 (T _C =127°C)	80	-40 to +150	0.59 (I _F =5.0A)	5	5.0	TO-220F	1.7
YG804S06R	60	15 (T _C =99°C)	120	-40 to +150	0.63 (I _F =15A)	20	2.2	TO-220F	1.7

() Conditions

*1: 50Hz Square wave duty=1/2

*2: Sine wave, 10ms *3: V_R=V_{RRM}

Letter symbols

V_{RRM} Repetitive peak reverse voltage
V_{RSM} Non-repetitive peak reverse voltage
I_O Average output current
I_{FSM} Surge current
T_{vj} Junction temperature
T_a Ambient temperature
T_c Case temperature

T_{stg} Storage temperature
V_{FM} Forward voltage
I_{RRM} Reverse current
t_{rr} Reverse recovery time
R_{th(j-c)} Thermal resistance (Junction to case)
T_l Lead temperature
I_{F(AV)} Average forward current

Schottky-Barrier Diodes(SBD)

2 in one-package

Device type	Maximum rating			Thermal rating T _{vj} and T _{stg} °C	Characteristics (T _a =25°C)			Package	Net mass Grams
	V _{RRM} Volts	I _O *1 Amps.	I _{FSM} *2 Amps.		V _{FM} *3 max. Volts	I _{RRM} *4 max.mA	R _{th(j-c)} °C/W		
KP883C02	20	7.0 (T _C =89°C)	60	-40 to +125	0.39 (I _F =2.5A)	10	10.0	K-Pack(L)	0.6
KS883C02	20	7.0 (T _C =89°C)	60	-40 to +125	0.39 (I _F =2.5A)	10	10.0	K-pack(S)	0.6
KS823C03	30	5.0 (T _C =117°C)	60	-40 to +150	0.47 (I _F =2.5A)	5	10.0	K-pack(S)	0.6
KS823C04	40	5.0 (T _C =107°C)	60	-40 to +150	0.55 (I _F =2.5A)	5	10.0	K-pack(S)	0.6
YG801C04R	40	5.0 (T _C =125°C)	100	-40 to +150	0.55 (I _F =2.0A)	5	5.0	TO-220F	1.7
YG802C04R	40	10 (T _C =110°C)	120	-40 to +150	0.55 (I _F =4.0A)	5	3.5	TO-220F	1.7
YG805C04R	40	20 (T _C =100°C)	120	-40 to +150	0.6 (I _F =10A)	15	2.5	TO-220F	1.7
YG838C04R	40	30 (T _C =85°C)	180	-40 to +150	0.53 (I _F =12.5A)	8	2.0	TO-220F	1.7
MS838C04	40	30 (T _C =111°C)	180	-40 to +150	0.53 (I _F =12.5A)	8	1.2	TFP	0.8
YG801C06R	60	5.0 (T _C =125°C)	60	-40 to +150	0.58 (I _F =2.0A)	5	5.0	TO-220F	1.7
YG802C06R	60	10 (T _C =118°C)	80	-40 to +150	0.58 (I _F =4.0A)	5	3.5	TO-220F	1.7
YG803C06R	60	15 (T _C =94°C)	100	-40 to +150	0.58 (I _F =6.0A)	5	3.0	TO-220F	1.7
YG805C06R	60	20 (T _C =108°C)	80	-40 to +150	0.58 (I _F =8.0A)	15	2.5	TO-220F	1.7
MS808C06	60	30 (T _C =118°C)	150	-40 to +150	0.58 (I _F =12.5A)	3	1.2	TFP	0.8
KS823C09	90	5.0 (T _C =100°C)	60	-40 to +150	0.9 (I _F =2.5A)	5	10.0	K-pack(S)	0.6
YG801C10R	100	5.0 (T _C =117°C)	60	-40 to +150	0.8 (I _F =1.5A)	0.7	5.0	TO-220F	1.7
YG802C10R	100	10 (T _C =102°C)	80	-40 to +150	0.8 (I _F =3.0A)	1.2	3.5	TO-220F	1.7
YG805C10R	100	20 (T _C =91°C)	100	-40 to +150	0.8 (I _F =5.0A)	2.5	2.5	TO-220F	1.7
YG808C10R	100	30 (T _C =80°C)	180	-40 to +150	0.8 (I _F =10A)	20	2.0	TO-220F	1.7

() Conditions



*1: 50Hz Square wave duty=1/2 (Average forward current of centertap full wave connection)

*2: Sine wave, 10ms per element *3: I_F=0.5I_O per element

*4: V_R=V_{RRM} per element



Ultra Low IR Schottky-Barrier Diodes

Ultra Low IR Schottky-Barrier Diodes					TO-220	TO-220F
						
Chip	V _{RRM} (V)	I _O (A)	V _F (V)	I _R (mA)		
Dual	100	10	0.82	0.015	✓	✓
		20	0.86	0.02	✓	✓
		30	0.86	0.03	✓	✓
	120	10	0.84	0.015	✓	✓
		20	0.88	0.02	✓	✓
		30	0.88	0.03	✓	✓
	150	10	0.86	0.015	✓	✓
		20	0.89	0.02	✓	✓
		30	0.89	0.03	✓	✓
	200	10	0.89	0.015	✓	✓
		20	0.93	0.02	✓	✓
		30	0.93	0.03	✓	✓

2 in one-package

Device type	Maximum rating			Thermal rating T _{vj} and T _{stg} °C	Characteristics (T _a =25°C)			Package	Net mass Grams
	V _{RRM} Volts	I _O *1 Amps.	I _{FSM} *2 Amps.		V _{FM} *3 max. Volts	I _{RRM} *4 max.mA	R _{th(j-c)} °C/W		
YG872C10R	100	10 (T _C =146°C)	125	-40 to +175	0.82	0.015	3.5	TO-220F	1.7
YA872C10R	100	10 (T _C =158°C)	125	-40 to +175	0.82	0.015	2.0	TO-220	2.0
YG875C10R	100	20 (T _C =131°C)	145	-40 to +175	0.86	0.020	2.5	TO-220F	1.7
YA875C10R	100	20 (T _C =144°C)	145	-40 to +175	0.86	0.020	1.75	TO-220	2.0
YG878C10R	100	30 (T _C =122°C)	160	-40 to +175	0.86	0.030	2.0	TO-220F	1.7
YA878C10R	100	30 (T _C =142°C)	160	-40 to +175	0.86	0.030	1.25	TO-220	2.0
YG872C12R	120	10 (T _C =143°C)	125	-40 to +175	0.84	0.015	3.5	TO-220F	1.7
YA872C12R	120	10 (T _C =158°C)	125	-40 to +175	0.84	0.015	2.0	TO-220	2.0
YG875C12R	120	20 (T _C =127°C)	145	-40 to +175	0.88	0.020	2.5	TO-220F	1.7
YA875C12R	120	20 (T _C =144°C)	145	-40 to +175	0.88	0.020	1.75	TO-220	2.0
YG878C12R	120	30 (T _C =116°C)	160	-40 to +175	0.88	0.030	2.0	TO-220F	1.7
YA878C12R	120	30 (T _C =141°C)	160	-40 to +175	0.88	0.030	1.25	TO-220	2.0
YG872C15R	150	10 (T _C =144°C)	125	-40 to +175	0.86	0.015	3.5	TO-220F	1.7
YA872C15R	150	10 (T _C =157°C)	125	-40 to +175	0.86	0.015	2.0	TO-220	2.0
YG875C15R	150	20 (T _C =130°C)	145	-40 to +175	0.89	0.020	2.5	TO-220F	1.7
YA875C15R	150	20 (T _C =143°C)	145	-40 to +175	0.89	0.020	1.75	TO-220	2.0
YG878C15R	150	30 (T _C =120°C)	160	-40 to +175	0.89	0.030	2.0	TO-220F	1.7
YA878C15R	150	30 (T _C =140°C)	160	-40 to +175	0.89	0.030	1.25	TO-220	2.0
YG872C20R	200	10 (T _C =143°C)	125	-40 to +175	0.89	0.015	3.5	TO-220F	1.7
YA872C20R	200	10 (T _C =157°C)	125	-40 to +175	0.89	0.015	2.0	TO-220	2.0
YG875C20R	200	20 (T _C =127°C)	145	-40 to +175	0.93	0.020	2.5	TO-220F	1.7
YA875C20R	200	20 (T _C =141°C)	145	-40 to +175	0.93	0.020	1.75	TO-220	2.0
YG878C20R	200	30 (T _C =116°C)	160	-40 to +175	0.93	0.030	2.0	TO-220F	1.7
YA878C20R	200	30 (T _C =138°C)	160	-40 to +175	0.93	0.030	1.25	TO-220	2.0

() Conditions

*1: 50Hz Square wave duty=1/2 (Average forward current of centertap full wave connection)

*2: Sine wave, 10ms per element

*3: I_F=0.5I_O per element

*4: V_R=V_{RRM} per element

Low IR Schottky-Barrier Diodes

Low IR Schottky-Barrier Diodes					TO-220	TO-220F	TO-3P (Q)	TO-3PF	TO-247	T-Pack(L)	T-Pack(S)	TFP
Chip	V _{RRM} (V)	I _O (A)	V _F (V)	I _R (mA)								
Single	120	5	0.88	0.15		✓						
	150	5	0.9	0.15		✓						
Dual	45	20	0.63	0.175	✓	✓					✓	✓
		30	0.63	0.2	✓	✓					✓	✓
	60	10	0.68	0.15	✓	✓					✓	
		20	0.74	0.175	✓	✓					✓	
		30	0.74	0.2	✓	✓					✓	
		40	0.7	0.2	✓	✓				✓		
	80	10	0.76	0.15	✓	✓					✓	✓
		20	0.76	0.175	✓	✓					✓	✓
		30	0.76	0.2	✓	✓					✓	
		40	0.71	0.2	✓	✓				✓		
	100	10	0.86	0.15	✓	✓					✓	
		20	0.86	0.175	✓	✓					✓	✓
		30	0.86	0.2	✓	✓	✓			✓	✓	✓
		40	0.82	0.2	✓	✓				✓		
	120	10	0.88	0.15	✓	✓					✓	✓
		20	0.88	0.15	✓	✓			✓	✓	✓	✓
30		0.88	0.2	✓	✓			✓	✓	✓	✓	
30		1.01	0.2									
40		0.95	0.2	✓	✓							
150	10	0.9	0.15	✓	✓				✓	✓		
	20	0.9	0.15	✓	✓		✓	✓	✓	✓	✓	
	30	0.9	0.2	✓	✓	✓		✓	✓	✓	✓	
	40	0.97	0.2	✓	✓							

1 in one-package

Device type	Maximum rating			Thermal rating T _{vj} and T _{stg} °C	Characteristics (T _a =25°C)			Package	Net mass Grams
	V _{RRM} Volts	I _O *1 Amps.	I _{FSM} *2 Amps.		V _{FM} *3 max. Volts	I _{RRM} *4 max. mA	R _{th(j-c)} °C/W		
YG861S12R	120	5 (T _C =104°C)	75	-40 to +150	0.88	0.15	5.0	TO-220F	1.7
YG861S15R	150	5 (T _C =94°C)	75	-40 to +150	0.90	0.15	5.0	TO-220F	1.7

() Conditions

*1: 50Hz Square wave duty=1/2

*2: Sine wave, 10ms *3: I_F=I_O

*4: V_R=V_{RRM}



Low IR Schottky-Barrier Diodes

2 in one-package

Device type	Maximum rating			Thermal rating T _{vj} and T _{stg} °C	Characteristics (T _a =25°C)			Package	Net mass Grams
	V _{RRM} Volts	I _O *1 Amps.	I _{FSM} *2 Amps.		V _{FM} *3 max. Volts	I _{RRM} *4 max.mA	R _{th(j-c)} °C/W		
YG865C04R	45	20 (T _C =115°C)	145	-40 to +150	0.63	0.175	2.5	TO-220F	1.7
YA865C04R	45	20 (T _C =126°C)	145	-40 to +150	0.63	0.175	1.75	TO-220	2.0
TS865C04R	45	20 (T _C =126°C)	145	-40 to +150	0.63	0.175	1.75	T-pack(S)	1.6
MS865C04	45	20 (T _C =125°C)	145	-40 to +150	0.63	0.175	1.75	TFP	0.8
YG868C04R	45	30 (T _C =105°C)	160	-40 to +150	0.63	0.20	2.0	TO-220F	1.7
YA868C04R	45	30 (T _C =122°C)	160	-40 to +150	0.63	0.20	1.25	TO-220	2.0
TS868C04R	45	30 (T _C =122°C)	160	-40 to +150	0.63	0.20	1.25	T-pack(S)	1.6
MS868C04	45	30 (T _C =122°C)	160	-40 to +150	0.63	0.20	1.25	TFP	0.8
YG862C06R	60	10 (T _C =124°C)	125	-40 to +150	0.68	0.15	3.5	TO-220F	1.7
YA862C06R	60	10 (T _C =136°C)	125	-40 to +150	0.68	0.15	2.0	TO-220	2.0
TS862C06R	60	10 (T _C =136°C)	125	-40 to +150	0.68	0.15	2.0	T-pack(S)	1.6
YG865C06R	60	20 (T _C =109°C)	145	-40 to +150	0.74	0.175	2.5	TO-220F	1.7
YA865C06R	60	20 (T _C =122°C)	145	-40 to +150	0.74	0.175	1.75	TO-220	2.0
TS865C06R	60	20 (T _C =122°C)	145	-40 to +150	0.74	0.175	1.75	T-pack(S)	1.6
YG868C06R	60	30 (T _C =101°C)	160	-40 to +150	0.74	0.20	2.0	TO-220F	1.7
YA868C06R	60	30 (T _C =119°C)	160	-40 to +150	0.74	0.20	1.25	TO-220	2.0
TS868C06R	60	30 (T _C =119°C)	160	-40 to +150	0.74	0.20	1.25	T-pack(S)	1.6
YG869C06R	60	40 (T _C =105°C)	190	-40 to +150	0.70	0.20	1.2	TO-220F	1.7
YA869C06R	60	40 (T _C =114°C)	190	-40 to +150	0.70	0.20	1.0	TO-220	2.0
TP869C06R	60	40 (T _C =114°C)	190	-40 to +150	0.70	0.20	1.0	T-Pack(L)	1.6
YG862C08R	80	10 (T _C =109°C)	125	-40 to +150	0.76	0.15	3.5	TO-220F	1.7
YA862C08R	80	10 (T _C =126°C)	125	-40 to +150	0.76	0.15	2.0	TO-220	2.0
TS862C08R	80	10 (T _C =126°C)	125	-40 to +150	0.76	0.15	2.0	T-pack(S)	1.6
MS862C08	80	10 (T _C =115°C)	125	-40 to +150	0.76	0.15	3.0	TFP	0.8
YG865C08R	80	20 (T _C =89°C)	145	-40 to +150	0.76	0.175	2.5	TO-220F	1.7
YA865C08R	80	20 (T _C =107°C)	145	-40 to +150	0.76	0.175	1.75	TO-220	2.0
TS865C08R	80	20 (T _C =107°C)	145	-40 to +150	0.76	0.175	1.75	T-pack(S)	1.6
MS865C08	80	20 (T _C =108°C)	145	-40 to +150	0.76	0.175	1.75	TFP	0.8
YG868C08R	80	30 (T _C =72°C)	160	-40 to +150	0.76	0.20	2.0	TO-220F	1.7
YA868C08R	80	30 (T _C =105°C)	160	-40 to +150	0.76	0.20	1.25	TO-220	2.0
TS868C08R	80	30 (T _C =105°C)	160	-40 to +150	0.76	0.20	1.25	T-pack(S)	1.6
YG869C08R	80	40 (T _C =86°C)	190	-40 to +150	0.71	0.20	1.2	TO-220F	1.7
YA869C08R	80	40 (T _C =98°C)	190	-40 to +150	0.71	0.20	1.0	TO-220	2.0
TP869C08R	80	40 (T _C =98°C)	190	-40 to +150	0.71	0.20	1.0	T-Pack(L)	1.6

() Conditions

*1: 50Hz Square wave duty=1/2 (Average forward current of centertap full wave connection)

*2: Sine wave, 10ms per element

*3: I_F=0.5I_O per element

*4: V_R=V_{RRM} per element

Low IR Schottky-Barrier Diodes

2 in one-package

Device type	Maximum rating			Thermal rating T _{vj} and T _{stg} °C	Characteristics (T _a =25°C)			Package	Net mass Grams
	V _{RRM} Volts	I _O *1 Amps.	I _{FSM} *2 Amps.		V _{FM} *3 max. Volts	I _{RRM} *4 max.mA	R _{th(j-c)} °C/W		
YG862C10R	100	10 (T _C =118°C)	125	-40 to +150	0.86	0.15	3.5	TO-220F	1.7
YA862C10R	100	10 (T _C =132°C)	125	-40 to +150	0.86	0.15	2.0	TO-220	2.0
TS862C10R	100	10 (T _C =132°C)	125	-40 to +150	0.86	0.15	2.0	T-pack(S)	1.6
YG865C10R	100	20 (T _C =103°C)	145	-40 to +150	0.86	0.175	2.5	TO-220F	1.7
YA865C10R	100	20 (T _C =117°C)	145	-40 to +150	0.86	0.175	1.75	TO-220	2.0
TS865C10R	100	20 (T _C =117°C)	145	-40 to +150	0.86	0.175	1.75	T-pack(S)	1.6
MS865C10	100	20 (T _C =117°C)	145	-40 to +150	0.86	0.175	1.75	TFP	0.8
YG868C10R	100	30 (T _C =91°C)	160	-40 to +150	0.86	0.20	2.0	TO-220F	1.7
YA868C10R	100	30 (T _C =113°C)	160	-40 to +150	0.86	0.20	1.25	TO-220	2.0
TS868C10R	100	30 (T _C =113°C)	160	-40 to +150	0.86	0.20	1.25	T-pack(S)	1.6
TP868C10R	100	30 (T _C =113°C)	160	-40 to +150	0.86	0.20	1.25	T-Pack(L)	1.6
MS868C10	100	30 (T _C =114°C)	160	-40 to +150	0.86	0.20	1.2	TFP	0.8
PA868C10R	100	30 (T _C =107°C)	160	-40 to +150	0.86	0.20	1.5	TO-3P(Q)	5.1
YG869C10R	100	40 (T _C =94°C)	190	-40 to +150	0.82	0.20	1.2	TO-220F	1.7
YA869C10R	100	40 (T _C =105°C)	190	-40 to +150	0.82	0.20	1.0	TO-220	2.0
TP869C10R	100	40 (T _C =105°C)	190	-40 to +150	0.82	0.20	1.0	T-Pack(L)	1.6
YG862C12R	120	10 (T _C =122°C)	75	-40 to +150	0.88	0.15	3.00	TO-220F	1.7
YA862C12R	120	10 (T _C =137°C)	75	-40 to +150	0.88	0.15	1.20	TO-220	2.0
TP862C12R	120	10 (T _C =137°C)	75	-40 to +150	0.88	0.15	1.50	T-Pack(L)	1.6
TS862C12R	120	10 (T _C =137°C)	75	-40 to +150	0.88	0.15	1.50	T-pack(S)	1.6
YG865C12R	120	20 (T _C =116°C)	150	-40 to +150	0.88	0.15	1.75	TO-220F	1.7
YA865C12R	120	20 (T _C =126°C)	150	-40 to +150	0.88	0.15	1.25	TO-220	2.0
PH865C12	120	20 (T _C =126°C)	150	-40 to +150	0.88	0.15	1.50	TO-247	4.9
TP865C12R	120	20 (T _C =126°C)	150	-40 to +150	0.88	0.15	1.25	T-Pack(L)	1.6
TS865C12R	120	20 (T _C =126°C)	150	-40 to +150	0.88	0.15	1.25	T-pack(S)	1.6
MS865C12	120	20 (T _C =126°C)	150	-40 to +150	0.88	0.15	1.25	TFP	0.8
YG868C12R	120	30 (T _C =116°C)	190	-40 to +150	0.88	0.20	1.20	TO-220F	1.7
YA868C12R	120	30 (T _C =122°C)	190	-40 to +150	0.88	0.20	1.00	TO-220	2.0
PH868C12	120	30 (T _C =122°C)	190	-40 to +150	0.88	0.20	1.20	TO-247	4.9
TS868C12R	120	30 (T _C =122°C)	190	-40 to +150	0.88	0.20	1.00	T-pack(S)	1.6
MS868C12	120	30 (T _C =115°C)	190	-40 to +150	0.88	0.20	1.20	TFP	0.8
YG869C12R	120	40 (T _C =95°C)	190	-40 to +150	0.95	0.20	1.20	TO-220F	1.7
YA869C12R	120	40 (T _C =104°C)	190	-40 to +150	0.95	0.20	1.00	TO-220	2.0
YG862C15R	150	10 (T _C =117°C)	75	-40 to +150	0.90	0.15	3.00	TO-220F	1.7
YA862C15R	150	10 (T _C =134°C)	75	-40 to +150	0.90	0.15	1.50	TO-220	2.0
TP862C15R	150	10 (T _C =134°C)	75	-40 to +150	0.90	0.15	1.50	T-Pack(L)	1.6
TS862C15R	150	10 (T _C =134°C)	75	-40 to +150	0.90	0.15	1.50	T-pack(S)	1.6
YG865C15R	150	20 (T _C =101°C)	150	-40 to +150	0.90	0.15	1.75	TO-220F	1.7
PH865C15	150	20 (T _C =109°C)	150	-40 to +150	0.90	0.15	1.50	TO-247	4.9
PG865C15R	150	20 (T _C =80°C)	150	-40 to +150	0.90	0.15	2.50	TO-3PF	6.0
YA865C15R	150	20 (T _C =115°C)	150	-40 to +150	0.90	0.15	1.25	TO-220	2.0
TP865C15R	150	20 (T _C =115°C)	150	-40 to +150	0.90	0.15	1.25	T-Pack(L)	1.6
TS865C15R	150	20 (T _C =115°C)	150	-40 to +150	0.90	0.15	1.25	T-pack(S)	1.6
MS865C15	150	20 (T _C =115°C)	150	-40 to +150	0.90	0.15	1.25	TFP	0.8
YG868C15R	150	30 (T _C =113°C)	190	-40 to +150	0.90	0.20	1.20	TO-220F	1.7
YA868C15R	150	30 (T _C =119°C)	190	-40 to +150	0.90	0.20	1.00	TO-220	2.0
TS868C15R	150	30 (T _C =119°C)	190	-40 to +150	0.90	0.20	1.00	T-pack(S)	1.6
MS868C15	150	30 (T _C =113°C)	190	-40 to +150	0.90	0.20	1.20	TFP	0.8
PA868C15R	150	30 (T _C =129°C)	190	-40 to +150	0.90	0.20	1.20	TO-3P	5.5
PH868C15	150	30 (T _C =129°C)	190	-40 to +150	0.90	0.20	1.20	TO-247	4.9
YG869C15R	150	40 (T _C =90°C)	190	-40 to +150	0.97	0.20	1.20	TO-220F	1.7
YA869C15R	150	40 (T _C =100°C)	190	-40 to +150	0.97	0.20	1.00	TO-220	2.0

() Conditions



*1: 50Hz Square wave duty=1/2 (Average forward current of centertap full wave connection)

*2: Sine wave, 10ms per element

*3: I_F=0.5I_O per element

*4: V_R=V_{RRM} per element

Super LLD 2 (Critical mode PFC)

Super LLD 2 (Critical mode PFC)						TO-220	TO-220F	TO-247
								
Chip	V _{RRM} (V)	I _O (A)	V _F (V)	I _R (μA)	t _{rr} (μsec)			
Single	600	8	1.55	10	0.05	✓	✓	
		10	1.55	10	0.05	✓	✓	
	800	5	2.2	10	0.05		✓	
Dual	600	10	1.55	10	0.05	✓	✓	✓

1 in one-package

Device type	Maximum rating			Thermal rating T _{vj} and T _{stg} °C	Characteristics (T _a =25°C)				Package	Net mass Grams
	V _{RRM} Volts	I _O *1 Amps.	I _{FSM} *2 Amps.		V _{FM} max. Volts	I _{RRM} *3 max. μA	t _{rr} *4 μ sec.	R _{th(j-c)} °C/W		
YA971S6R	600	8 (T _C =116°C)	70	-40 to +150	1.55 (f=8A)	10	0.05	2.5	TO-220	2.0
YG971S6R	600	8 (T _C =89°C)	70	-40 to +150	1.55 (f=8A)	10	0.05	4.5	TO-220F	1.7
YA972S6R	600	10 (T _C =115°C)	100	-40 to +150	1.55 (f=10A)	10	0.05	2.0	TO-220	2.0
YG972S6R	600	10 (T _C =89°C)	100	-40 to +150	1.55 (f=10A)	10	0.05	3.5	TO-220F	1.7
YG971S8R	800	5 (T _C =93°C)	60	-40 to +150	2.2 (f=5A)	10	0.05	4.5	TO-220F	1.7

() Conditions

*1: 50Hz Square wave duty=1/2

*2: Sine wave, 10ms *3: V_R=V_{RRM}

*4: I_F=0.1A, I_R=0.2A, I_{rec}=0.05A

2 in one-package

Device type	Maximum rating			Thermal rating T _{vj} and T _{stg} °C	Characteristics (T _a =25°C)				Package	Net mass Grams
	V _{RRM} Volts	I _O *1 Amps.	I _{FSM} *2 Amps.		V _{FM} max. Volts	I _{RRM} *3 max. μA	t _{rr} *4 μ sec.	R _{th(j-c)} °C/W		
YA975C6R	600	20 (T _C =106°C)	100	-40 to +150	1.55 (f=10A)	10	0.05	1.25	TO-220	2.0
YG975C6R	600	20 (T _C =89°C)	100	-40 to +150	1.55 (f=10A)	10	0.05	1.75	TO-220F	1.7
PH975C6	600	20 (T _C =97°C)	100	-40 to +150	1.55 (f=10A)	10	0.05	1.5	TO-247	4.9





() Conditions

*1: 50Hz Square wave duty=1/2 (Average forward current of centertap full wave connection)

*2: Sine wave, 10ms per element *3: V_R=V_{RRM} per element

*4: I_F=0.1A, I_R=0.2A, I_{rec}=0.05A

■ Super LLD 3 (Continuous mode PFC)

Super LLD 3 (Continuous mode PFC)						TO-220	TO-220F	TO-247	T-Pack (S)
									
Chip	V_{RRM} (V)	I_O (A)	V_F (V)	I_R (μ A)	t_{rr} (μ sec)				
Single	600	8	3	25	0.026	✓	✓		
		10	3	30	0.028	✓	✓		
Dual	600	16	3	25	0.026	✓	✓		✓
		20	3	30	0.028	✓	✓	✓	✓

1 in one-package

Device type	Maximum rating			Thermal rating T_{vj} and T_{stg} °C	Characteristics ($T_a=25^\circ\text{C}$)				Package	Net mass Grams
	V_{RRM} Volts	I_O *1 Amps.	I_{FSM} *2 Amps.		V_{FM} max. Volts	I_{RRM} *3 max. μ A	t_{rr} *4 μ sec.	$R_{th(j-c)}$ °C/W		
YA981S6R	600	8 ($T_C=99^\circ\text{C}$)	40	-40 to +150	3.0 ($I_F=8\text{A}$)	25	0.026	2.5	TO-220	2.0
YG981S6R	600	8 ($T_C=58^\circ\text{C}$)	40	-40 to +150	3.0 ($I_F=8\text{A}$)	25	0.026	4.5	TO-220F	1.7
YA982S6R	600	10 ($T_C=99^\circ\text{C}$)	50	-40 to +150	3.0 ($I_F=10\text{A}$)	30	0.028	2.0	TO-220	2.0
YG982S6R	600	10 ($T_C=60^\circ\text{C}$)	50	-40 to +150	3.0 ($I_F=10\text{A}$)	30	0.028	3.5	TO-220F	1.7

() Conditions

*1: 50Hz Square wave duty=1/2

*2: Sine wave, 10ms

*3: $V_R=V_{RRM}$

*4: $I_F=0.1\text{A}$, $I_R=0.2\text{A}$, $I_{rec}=0.05\text{A}$

2 in one-package

Device type	Maximum rating			Thermal rating T_{vj} and T_{stg} °C	Characteristics ($T_a=25^\circ\text{C}$)				Package	Net mass Grams
	V_{RRM} Volts	I_O *1 Amps.	I_{FSM} *2 Amps.		V_{FM} max. Volts	I_{RRM} *3 max. μ A	t_{rr} *4 μ sec.	$R_{th(j-c)}$ °C/W		
YA982C6R	600	16 ($T_C=88^\circ\text{C}$)	40	-40 to +150	3.0 ($I_F=8\text{A}$)	25	0.026	1.5	TO-220	2.0
TS982C6R	600	16 ($T_C=88^\circ\text{C}$)	40	-40 to +150	3.0 ($I_F=8\text{A}$)	25	0.026	1.5	T-pack(S)	1.6
YG982C6R	600	16 ($T_C=68^\circ\text{C}$)	40	-40 to +150	3.0 ($I_F=8\text{A}$)	25	0.026	2	TO-220F	1.7
YA985C6R	600	20 ($T_C=86^\circ\text{C}$)	50	-40 to +150	3.0 ($I_F=10\text{A}$)	30	0.028	1.25	TO-220	2.0
TS985C6R	600	20 ($T_C=86^\circ\text{C}$)	50	-40 to +150	3.0 ($I_F=10\text{A}$)	30	0.028	1.25	T-pack(S)	1.6
YG985C6R	600	20 ($T_C=60^\circ\text{C}$)	50	-40 to +150	3.0 ($I_F=10\text{A}$)	30	0.028	1.75	TO-220F	1.7
PH985C6	600	20 ($T_C=73^\circ\text{C}$)	50	-40 to +150	3.0 ($I_F=10\text{A}$)	30	0.028	1.5	TO-247	4.9





() Conditions

*1: 50Hz Square wave duty 1/2 (Average forward current of centertap full wave connection)

*2: Sine wave, 10ms per element *3: $V_R=V_{RRM}$ per element

*4: $I_F=0.1\text{A}$, $I_R=0.2\text{A}$, $I_{rec}=0.05\text{A}$

Low-Loss Fast Recovery Diodes (LLD)

Low-Loss Fast Recovery Diodes (LLD)						TO-220F	K-Pack(L)	K-Pack(S)	TFP
									
Chip	V _{RRM} (V)	I _O (A)	V _F (V)	I _R (μA)	t _{rr} (μsec)				
Single	200	5	0.95	100	0.035	✓	✓	✓	
		10	0.98	200	0.035	✓			
	300	5	1.2	100	0.035	✓			
Dual	200	5	0.95	100	0.035	✓	✓	✓	
		10	0.95	100	0.035	✓			
		20	0.98	200	0.035	✓			✓
	300	5	1.2	100	0.035	✓			
		10	1.2	100	0.035	✓			
		20	1.2	200	0.035				✓

1 in one-package

Device type	Maximum rating			Thermal rating T _{vj} and T _{stg} °C	Characteristics (T _a =25°C)				Package	Net mass Grams
	V _{RRM} Volts	I _O *1 Amps.	I _{FSM} *2 Amps.		V _{FM} *3 max. Volts	I _{RRM} *4 max. μA	t _{rr} *5 μ sec.	R _{th(j-c)} °C/W		
KP926S2	200	5 (T _C =106°C)	70	-40 to +150	0.95	100	0.035	10.0	K-Pack(L)	0.6
KS926S2	200	5 (T _C =106°C)	70	-40 to +150	0.95	100	0.035	10.0	K-pack(S)	0.6
YG911S2R	200	5 (T _C =134°C)	50	-40 to +150	0.95	100	0.035	3.5	TO-220F	1.7
YG912S2R	200	10 (T _C =116°C)	80	-40 to +150	0.98	200	0.035	3.5	TO-220F	1.7
YG911S3R	300	5 (T _C =128°C)	40	-40 to +150	1.2	100	0.035	3.5	TO-220F	1.7

() Conditions

*1: 50Hz Square wave duty 1/2

*2: Sine wave, 10ms *3: I_F=I_O

*5: I_F=0.1A. I_R=0.2A. I_{rec}=0.05A

*4: V_R=V_{RRM}

2 in one-package

Device type	Maximum rating			Thermal rating T _{vj} and T _{stg} °C	Characteristics (T _a =25°C)				Package	Net mass Grams
	V _{RRM} Volts	I _O *1 Amps.	I _{FSM} *2 Amps.		V _{FM} *3 max. Volts	I _{RRM} *4 max. μA	t _{rr} *5 μ sec.	R _{th(j-c)} °C/W		
KP923C2	200	5 (T _C =103°C)	50	-40 to +150	0.95	100	0.035	10.0	K-Pack(L)	0.6
KS923C2	200	5 (T _C =103°C)	50	-40 to +150	0.95	100	0.035	10.0	K-pack(S)	0.6
YG901C2R	200	5 (T _C =120°C)	25	-40 to +150	0.95	100	0.035	5.0	TO-220F	1.7
YG902C2R	200	10 (T _C =115°C)	50	-40 to +150	0.95	100	0.035	3.5	TO-220F	1.7
YG906C2R	200	20 (T _C =102°C)	80	-40 to +150	0.98	200	0.035	2.5	TO-220F	1.7
MS906C2	200	20 (T _C =105°C)	80	-40 to +150	0.98	200	0.035	2.0	TFP	0.8
YG901C3R	300	5 (T _C =105°C)	25	-40 to +150	1.2	100	0.035	5.0	TO-220F	1.7
YG902C3R	300	10 (T _C =101°C)	40	-40 to +150	1.2	100	0.035	3.5	TO-220F	1.7
MS906C3	300	20 (T _C =95°C)	80	-40 to +150	1.2	200	0.035	2.0	TFP	0.8

() Conditions

*1: 50Hz Square wave duty=1/2 (Average forward current of centertap full wave connection)







*2: Sine wave, 10ms per element

*3: I_F=0.5I_O per element

*4: V_R=V_{RRM} per element

*5: I_F=0.1A. I_R=0.2A. I_{rec}=0.05A

Low-Loss Fast Soft Recovery Diodes (LLD)

Low-Loss Fast Soft Recovery Diodes (LLD)						TO-220	TO-220F	TO-3PF	T-Pack (S)	K-Pack (S)	TFP
											
Chip	V _{RRM} (V)	I _O (A)	V _F (V)	I _R (μA)	t _{rr} (μsec)						
Single	300	5	1.3	20	0.04					✓	
	400	5	1.45	20	0.05					✓	
Dual	300	10	1.3	20	0.04	✓	✓		✓		
		20	1.3	35	0.04	✓	✓	✓	✓		✓
	400	10	1.45	20	0.05	✓	✓		✓		
		20	1.45	35	0.05	✓	✓	✓	✓		✓

1 in one-package

Device type	Maximum rating			Thermal rating T _{vj} and T _{stg} °C	Characteristics (T _a =25°C)				Package	Net mass Grams
	V _{RRM} Volts	I _O *1 Amps.	I _{FSM} *2 Amps.		V _{FM} *3 max. Volts	I _{RRM} *4 max. μA	t _{rr} *5 μ sec.	R _{th(j-c)} °C/W		
KS986S3	300	5 (T _C =128°C)	90	-40 to +150	1.3	20	0.04	3.5	K-pack(S)	0.6
KS986S4	400	5 (T _C =125°C)	80	-40 to +150	1.45	20	0.05	3.5	K-pack(S)	0.6

() Conditions

*1: 50Hz Square wave duty=1/2

*2: Sine wave, 10ms *3: I_F=I_O per element *4: V_R=V_{RRM}

*5: I_F=0.1A. I_R=0.2A. I_{rec}=0.05A

2 in one-package

Device type	Maximum rating			Thermal rating T _{vj} and T _{stg} °C	Characteristics (T _a =25°C)				Package	Net mass Grams
	V _{RRM} Volts	I _O *1 Amps.	I _{FSM} *2 Amps.		V _{FM} *3 max. Volts	I _{RRM} *4 max. μA	t _{rr} *5 μ sec.	R _{th(j-c)} °C/W		
YG982C3R	300	10 (T _C =112°C)	90	-40 to +150	1.3	20	0.04	3	TO-220F	1.7
YA982C3R	300	10 (T _C =128°C)	90	-40 to +150	1.3	20	0.04	1.75	TO-220	2.0
TS982C3R	300	10 (T _C =128°C)	90	-40 to +150	1.3	20	0.04	1.75	T-pack(S)	1.6
YG985C3R	300	20 (T _C =105°C)	110	-40 to +150	1.3	35	0.04	1.75	TO-220F	1.7
YA985C3R	300	20 (T _C =118°C)	110	-40 to +150	1.3	35	0.04	1.25	TO-220	2.0
TS985C3R	300	20 (T _C =118°C)	110	-40 to +150	1.3	35	0.04	1.25	T-pack(S)	1.6
MS985C3	300	20 (T _C =118°C)	110	-40 to +150	1.3	35	0.04	1.25	TFP	0.8
PG985C3R	300	20 (T _C =73°C)	110	-40 to +150	1.3	35	0.04	3	TO-3PF	6.0
YG982C4R	400	10 (T _C =107°C)	80	-40 to +150	1.45	20	0.05	3	TO-220F	1.7
YA982C4R	400	10 (T _C =125°C)	80	-40 to +150	1.45	20	0.05	1.75	TO-220	2.0
TS982C4R	400	10 (T _C =125°C)	80	-40 to +150	1.45	20	0.05	1.75	T-pack(S)	1.6
YG985C4R	400	20 (T _C =100°C)	100	-40 to +150	1.45	35	0.05	1.75	TO-220F	1.7
YA985C4R	400	20 (T _C =114°C)	100	-40 to +150	1.45	35	0.05	1.25	TO-220	2.0
TS985C4R	400	20 (T _C =114°C)	100	-40 to +150	1.45	35	0.05	1.25	T-pack(S)	1.6
MS985C4	400	20 (T _C =114°C)	100	-40 to +150	1.45	35	0.05	1.25	TFP	0.8
PG985C4R	400	20 (T _C =64°C)	100	-40 to +150	1.45	35	0.05	3	TO-3PF	6.0

() Conditions

*1: 50Hz Square wave duty=1/2 (Average forward current of centertap full wave connection)

*2: Sine wave, 10ms per element *3: I_F=0.5I_O per element

*4: V_R=V_{RRM} per element

*5: I_F=0.1A. I_R=0.2A. I_{rec}=0.05A



Schottky-Barrier Diodes (SBD)

Schottky-Barrier Diodes (SBD)					TO-3P(Q)	TO-3PF	T-Pack (S)	T-Pack (L)
Chip	V _{RRM} (V)	I _O (A)	V _F (V)	I _R (mA)				
Dual	40	10	0.55	5			✓	
		20	0.6	15			✓	
		30	0.55	20	✓	✓		
	60	30	0.58	20	✓	✓	✓	

2 in one-package

Device type	Maximum rating			Thermal rating T _{vj} and T _{stg} °C	Characteristics (T _a =25°C)			Package	Net mass Grams
	V _{RRM} Volts	I _O *1 Amps.	I _{FSM} *2 Amps.		V _{FM} *3 max. Volts	I _{RRM} *4 max. mA	R _{th(j-c)} °C/W		
TP802C04R	40	10 (T _C =116°C)	120	-40 to +150	0.55 (f=4.0A)	5	3.0	T-Pack(L)	1.6
TS802C04R	40	10 (T _C =116°C)	120	-40 to +150	0.55 (f=4.0A)	5	3.0	T-pack(S)	1.6
TS805C04R	40	20 (T _C =110°C)	120	-40 to +150	0.6 (f=10A)	15	2.0	T-pack(S)	1.6
ESAD83M-004RR	40	30 (T _C =105°C)	150	-40 to +150	0.55 (f=12.5A)	20	1.7	TO-3PF	6.0
ESAD83-004R	40	30 (T _C =118°C)	150	-40 to +150	0.55 (f=12.5A)	20	1.2	TO-3P	5.5
ESAD83M-006RR	60	30 (T _C =106°C)	120	-40 to +150	0.58 (f=12.5A)	20	1.7	TO-3PF	6.0
TS808C06R	60	30 (T _C =115°C)	120	-40 to +150	0.58 (f=12.5A)	20	1.2	T-pack(S)	1.6
ESAD83-006R	60	30 (T _C =119°C)	120	-40 to +150	0.58 (f=12.5A)	20	1.2	TO-3P	5.5

() Conditions

*1: 50Hz Square wave duty=1/2 (Average forward current of centertap full wave connection)

*2: Sine wave, 10ms per element

*3: per element

*4: V_R=V_{RRM} per element

Low-Loss Fast Recovery Diodes (LLD)

Low-Loss Fast Recovery Diodes (LLD)						TO-3P(Q)	TO-3PF	T-Pack (S)	T-Pack (L)	
Chip	V _{RRM} (V)	I _O (A)	V _F (V)	I _R (μA)	t _{rr} (μsec)					
Dual	200	5	0.95	100	0.035				✓	
		10	0.95	100	0.035			✓	✓	
		20	0.95	200	0.04		✓	✓		
		20	0.98	200	0.035			✓	✓	
	300	10	1.2	100	0.035			✓	✓	
		20	1.2	200	0.04		✓	✓		
	400	20	1.5	500	0.05	✓	✓			

2 in one-package

Device type	Maximum rating			Thermal rating T _{vj} and T _{stg} °C	Characteristics (T _a =25°C)			Package	Net mass Grams	
	V _{RRM} Volts	I _O *1 Amps.	I _{FSM} *2 Amps.		V _{FM} *3 max. Volts	I _{RRM} *4 max. μA	t _{rr} *5 μ sec.			R _{th(j-c)} °C/W
TP901C2R	200	5 (T _C =120°C)	25	-40 to +150	0.95 (f=2.5A)	100	0.035	5.0	T-Pack(L)	1.6
TP902C2R	200	10 (T _C =125°C)	50	-40 to +150	0.95 (f=5A)	100	0.035	2.5	T-Pack(L)	1.6
TS902C2R	200	10 (T _C =125°C)	50	-40 to +150	0.95 (f=5A)	100	0.035	2.5	T-pack(S)	1.6
ESAD92M-02RR	200	20 (T _C =108°C)	100	-40 to +150	0.95 (f=10A)	200	0.04	2.0	TO-3PF	6.0
TP906C2R	200	20 (T _C =110°C)	80	-40 to +150	0.98 (f=10A)	200	0.035	2.0	T-Pack(L)	1.6
TS906C2R	200	20 (T _C =110°C)	80	-40 to +150	0.98 (f=10A)	200	0.035	2.0	T-pack(S)	1.6
ESAD92-02R	200	20 (T _C =115°C)	100	-40 to +150	0.95 (f=10A)	200	0.04	1.5	TO-3P	5.5
TP902C3R	300	10 (T _C =115°C)	40	-40 to +150	1.2 (f=5A)	100	0.035	2.5	T-Pack(L)	1.6
TS902C3R	300	10 (T _C =115°C)	40	-40 to +150	1.2 (f=5A)	100	0.035	2.5	T-pack(S)	1.6
ESAD92-03R	300	20 (T _C =110°C)	80	-40 to +150	1.2 (f=10A)	200	0.04	1.5	TO-3P	5.5
ESAD92M-03RR	300	20 (T _C =96°C)	80	-40 to +150	1.2 (f=10A)	200	0.04	2.0	TO-3PF	6.0
ESAE92-03R	300	30 (T _C =99°C)	115	-40 to +150	1.2 (f=15A)	300	0.04	1.2	TO-3P	5.5
ESAF92-03R	300	60 (T _C =86°C)	240	-40 to +150	1.2 (f=30A)	600	0.04	0.75	TO-3P	5.5
PA905C4R	400	20 (T _C =107°C)	70	-40 to +150	1.5 (f=10A)	500	0.05	1.5	TO-3P	5.5

() Conditions

*1: 50Hz Square wave duty=1/2 (Average forward current of centertap full wave connection)





*2: Sine wave, 10ms per element

*3: per element

*4: V_R=V_{RRM} per element

*5: I_F=0.1A, I_R=0.2A, I_{rec.}=0.05A

Ultra Fast Recovery Diodes

Ultra Fast Recovery Diodes						TO-220	TO-247-2L-P2	TO-247-P2	TO-247-2-P2
									
Chip	V _{RRM} (V)	I _O (A)	V _F (V)	I _R (μA)	t _{rr} (μsec)				
Single	600	15	2.6	250	0.031	✓	✓		
		25	2.6	250	0.033	✓	✓		
		35	2.6	250	0.036		✓		
		75	2.95	250	0.060				✓
Dual	600	60	3.2	250	0.060				✓
		50	2.6	250	0.033			✓	
		70	2.6	250	0.036			✓	

1 in one-package

Device type	Maximum rating			Thermal rating T _{vj} and T _{stg} °C	Characteristics (T _a =25°C)				Package	Net mass Grams
	V _{RRM} Volts	I _O *1 Amps.	I _{FSM} *2 Amps.		V _{FM} *3 max. Volts	I _{RRM} *4 max. μA	t _{rr} *5 μ sec.	R _{th(j-c)} °C/W		
FDRP15S60L	600	15 (T _C =98°C)	110	-40 to +150	2.6	250	0.031	1.6	TO-220	2.0
FDRW15S60L	600	15 (T _C =85°C)	110	-40 to +150	2.6	250	0.031	2.0	TO-247-2L-P2	4.9
FDRP25S60L	600	25 (T _C =86°C)	125	-40 to +150	2.6	250	0.033	1.2	TO-220	2.0
FDRW25S60L	600	25 (T _C =86°C)	125	-40 to +150	2.6	250	0.033	1.2	TO-247-2L-P2	4.9
FDRW35S60L	600	35 (T _C =91°C)	140	-40 to +150	2.6	250	0.036	0.8	TO-247-2L-P2	4.9
FDRW75T60L	600	75 (T _C =49°C)	300	-40 to +150	2.95	250	0.060	0.57	TO-247-2-P2	4.9
FDRW60T65L	650	60 (T _C =50°C)	250	-40 to +150	3.2	250	0.060	0.68	TO-247-2-P2	4.9

() Conditions

*1: 50Hz Square wave duty=1/2

*2: Sine wave, 10ms 1shot *3: I_F=I_O

*4: V_R=V_{RRM} *5: V_R=30V, I_F=0.1 I_O, -di/dt=200A/us

2 in one-package

Device type	Maximum rating			Thermal rating T _{vj} and T _{stg} °C	Characteristics (T _a =25°C)				Package	Net mass Grams
	V _{RRM} Volts	I _O *1 Amps.	I _{FSM} *2 Amps.		V _{FM} *3 max. Volts	I _{RRM} *4 max. μA	t _{rr} *5 μ sec.	R _{th(j-c)} °C/W		
FDRW50C60L	600	50 (T _C =86°C)	125	-40 to +150	2.6	250	0.033	0.6	TO-247-P2	4.9
FDRW70C60L	600	70 (T _C =91°C)	140	-40 to +150	2.6	250	0.036	0.4	TO-247-P2	4.9

() Conditions

*1: 50Hz Square wave duty=1/2, Output Current of center tap full wave connection

*2: Sine wave, 10ms 1shot, Rating per element *3: I_F=0.5 I_O, Rating per element

*4: V_R=V_{RRM}, Rating per element

*5: V_R=30V, I_F=0.05 I_O, -di/dt=200A/us, Rating per element

Soft Recovery Fast Recovery Diodes

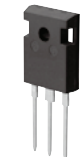
Soft Recovery Fast Recovery Diodes						TO-247-2L-P2	TO-247-P2
							
Chip	V _{RRM} (V)	I _O (A)	V _F (V)	I _R (μA)	t _{tr} (μsec)		
Single	1200	12	2.8	250	0.042	✓	
		20	2.8	250	0.055	✓	
		30	2.8	250	0.063	✓	
Dual	1200	40	2.8	250	0.055		✓
		60	2.8	250	0.063		✓

1 in one-package

Device type	Maximum rating			Thermal rating T _{vj} and T _{stg} °C	Characteristics (T _a =25°C)				Package	Net mass Grams
	V _{RRM} Volts	I _O *1 Amps.	I _{FSM} *2 Amps.		V _{FM} *3 max. Volts	I _{RRM} *4 max. μA	t _{tr} *5 μsec.	R _{th(j-c)} °C/W		
FDRW12S120J	1200	12 (T _C =97°C)	100	-40 to +150	2.8	250	0.042	1.6	TO-247-2L-P2	4.9
FDRW20S120J	1200	20 (T _C =88°C)	120	-40 to +150	2.8	250	0.055	1.2	TO-247-2L-P2	4.9
FDRW30S120J	1200	30 (T _C =89°C)	150	-40 to +150	2.8	250	0.063	0.781	TO-247-2L-P2	4.9

() Conditions

*1: 50Hz Square wave duty=1/2

*2: Sine wave, 10ms 1shot *3: I_F=I_O

*4: V_R=V_{RRM} *5: V_R=30V, I_F=0.1 I_O, -di/dt=200A/us

2 in one-package

Device type	Maximum rating			Thermal rating T _{vj} and T _{stg} °C	Characteristics (T _a =25°C)				Package	Net mass Grams
	V _{RRM} Volts	I _O *1 Amps.	I _{FSM} *2 Amps.		V _{FM} *3 max. Volts	I _{RRM} *4 max. μA	t _{tr} *5 μsec.	R _{th(j-c)} °C/W		
FDRW40C120J	1200	40 (T _C =98°C)	120	-40 to +150	2.8	250	0.055	0.5	TO-247-P2	4.9
FDRW60C120J	1200	60 (T _C =87°C)	150	-40 to +150	2.8	250	0.063	0.397	TO-247-P2	4.9

() Conditions

*1: 50Hz Square wave duty=1/2, Output Current of center tap full wave connection

*2: Sine wave, 10ms 1shot, Rating per element *3: I_F=0.5 I_O, Rating per element

*4: V_R=V_{RRM}, Rating per element

*5: V_R=30V, I_F=0.05 I_O, -di/dt=200A/us, Rating per element

Pressure Sensors



Fuji Electric's pressure sensors combine piezo resistance, adjustment circuits, and EMC protection on single chip and contribute to reduction of system size. They operate in wide pressure range and are applicable to various uses.



Features of Pressure Sensors

- Absolute pressure measurement
- High accuracy with digital trimming
- Wide pressure range, full scale of 100kPa to 300kPa
- Provided with overvoltage protection circuit, EMC filter, and surge protective device in the sensor chip
- Surge protection conforms to ISO7637-level 3 (2011) for automotive components
- Diagnostic self-detecting function in the event of a wire opened among Vcc, Vout and GND terminals
- High reliability ensured by EPROM bit redundancy

Products

Device type	Max. applied voltage (kPa.abs)	Allowable voltage (V)	Operating temperature (°C)	Operating pressure (kPa.abs)	Operating voltage (V)	Output Voltage range (V)	Absolute pressure/ Relative pressure	Package
EPL4PC-R3S	500	7	-40 to 125	20 to 106.7	5.0±0.25	0.789 to 4.211	Absolute pressure	Assembly type
EPL6GC-R3S	500	7	-40 to 125	25 to 242	5.0±0.25	0.5 to 4.5	Absolute pressure	Assembly type

Dimensions, mm

Direct mounting type

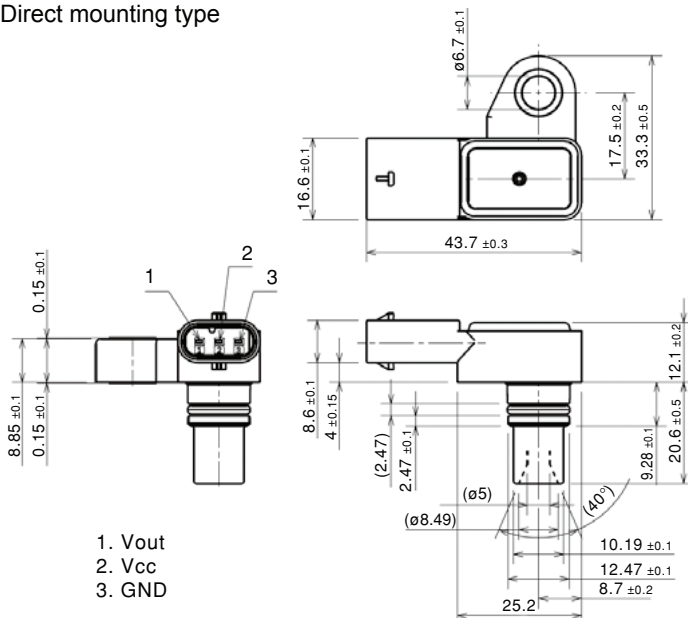

Outline

<Power devices>

Unit: mm

M151

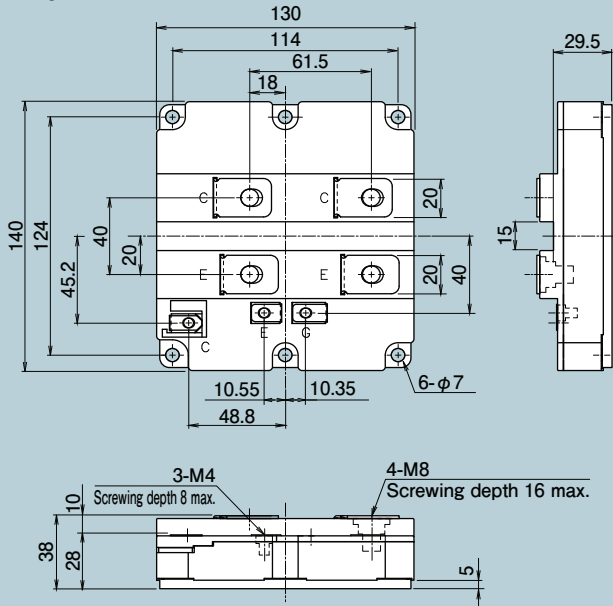

M152

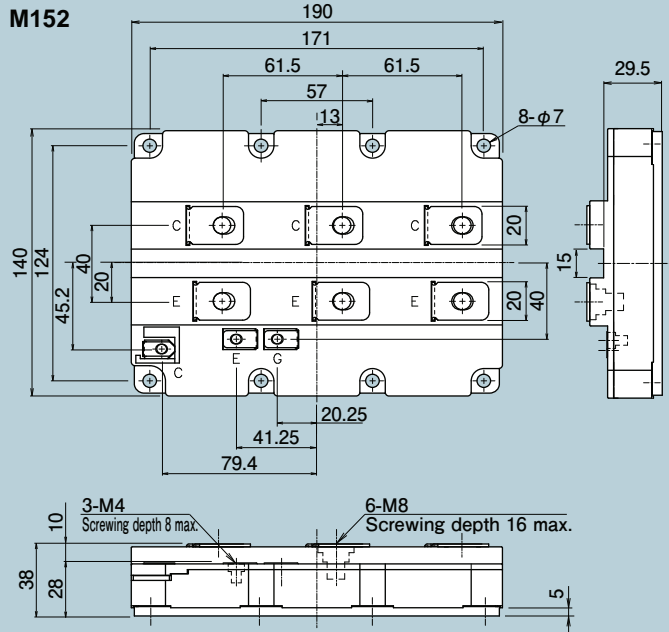

M153

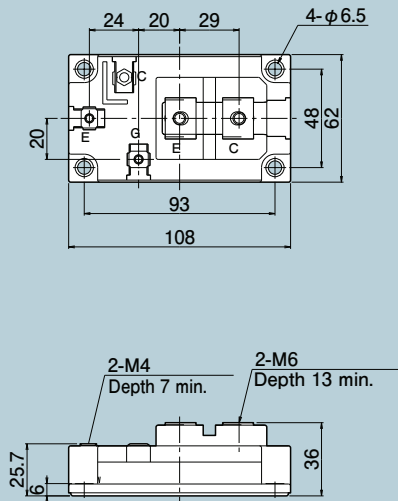

M155

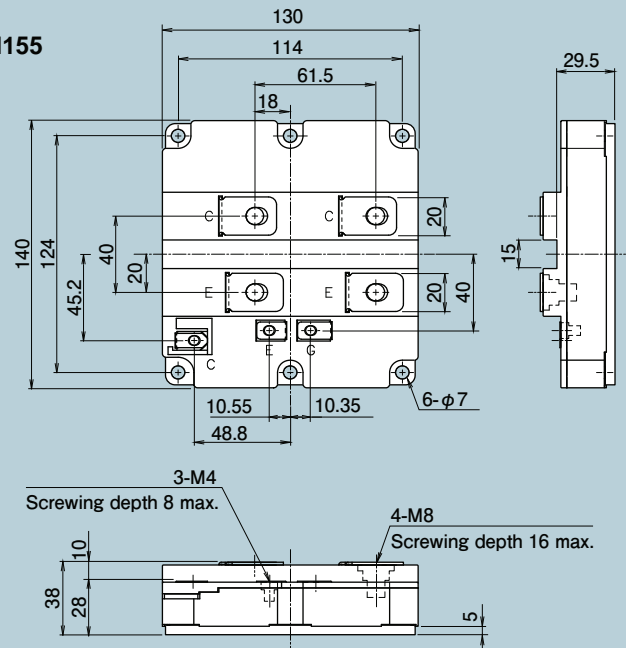

Unit: mm

M156

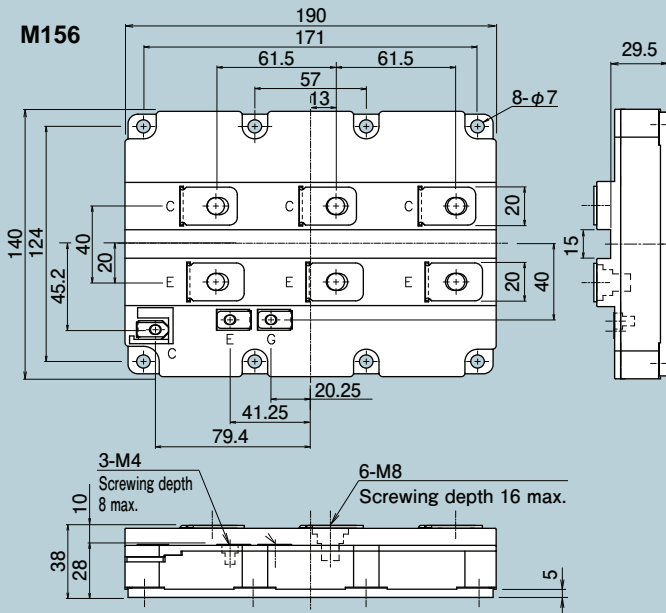

M233

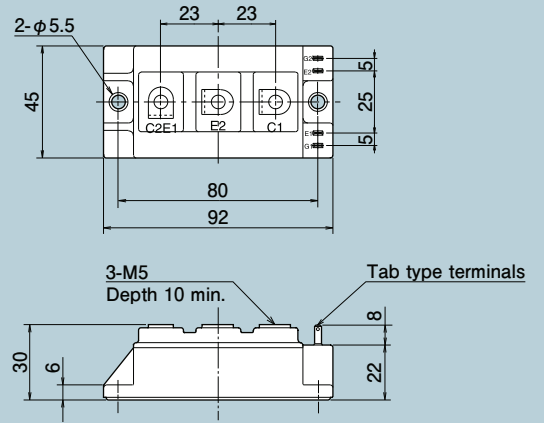

M249

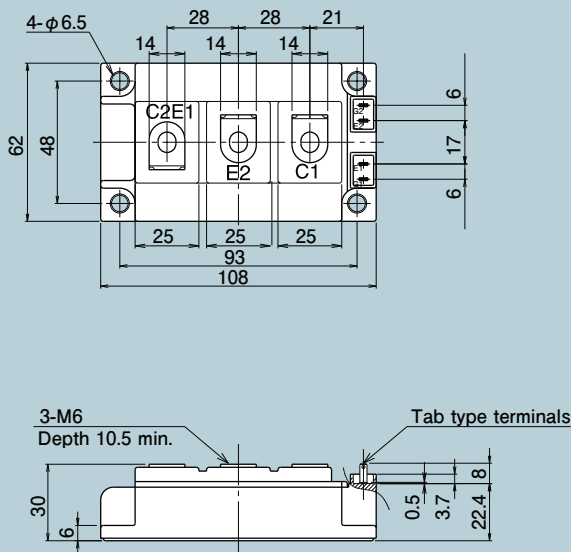

M256

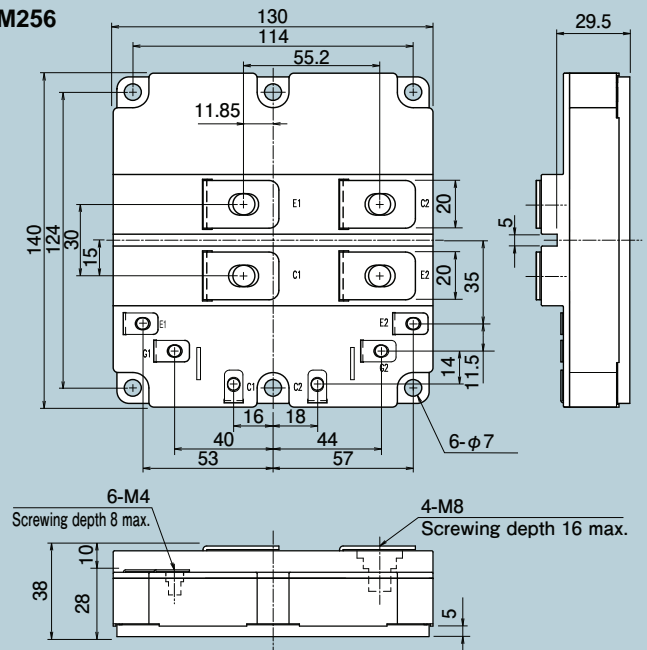

M254

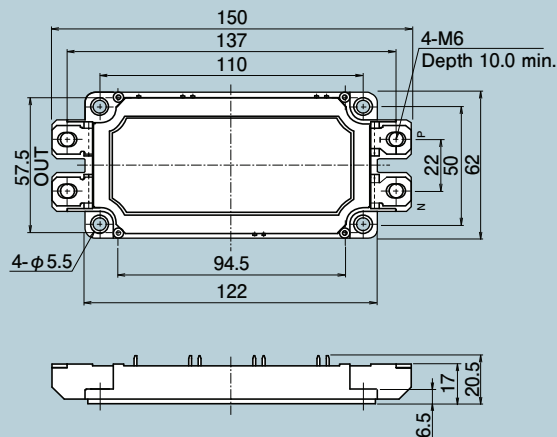

M259

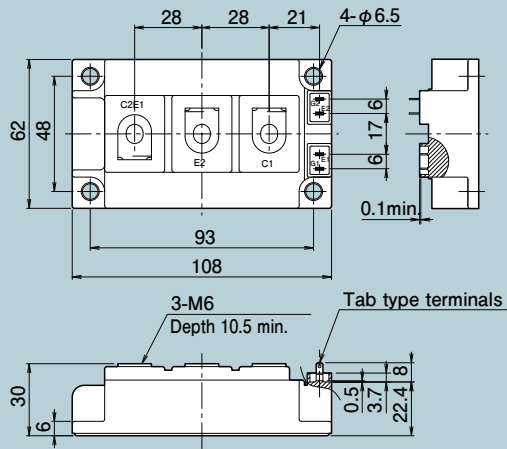

M260

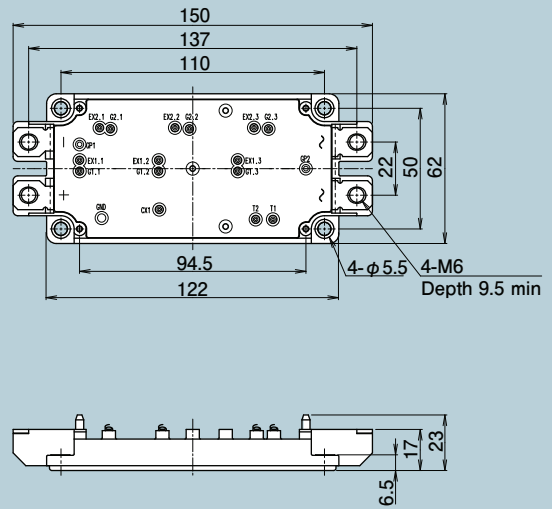

M262

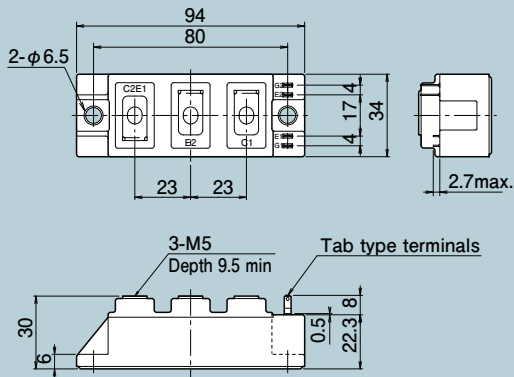

M263

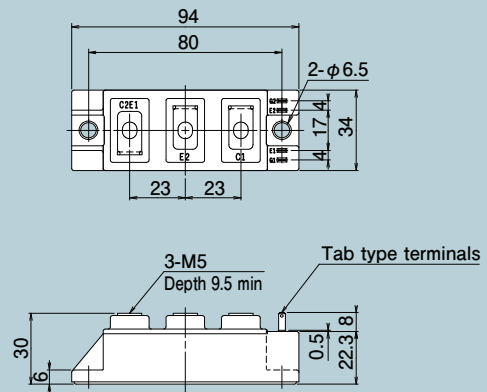

M271

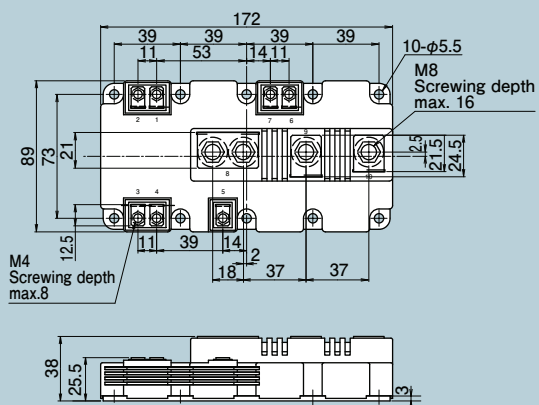

M272

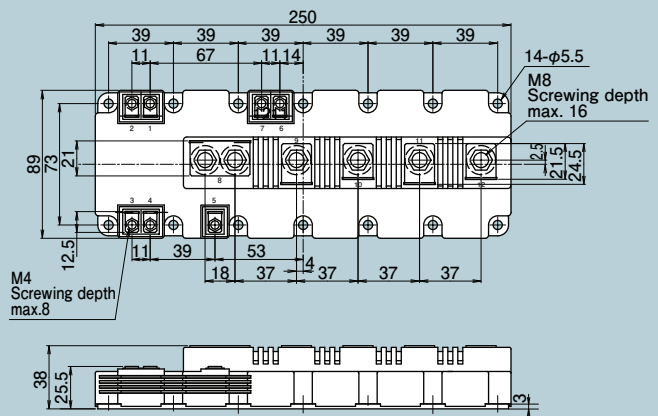

Unit: mm

M274

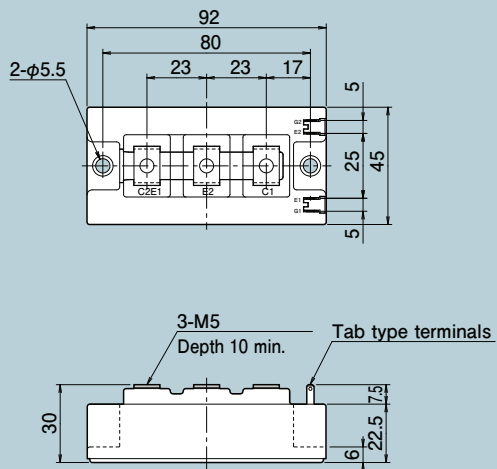

M275

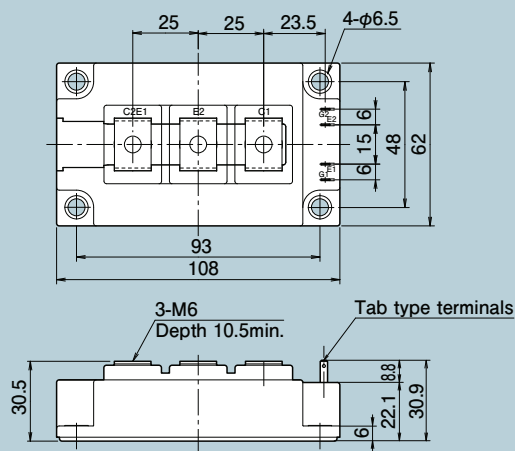

M276

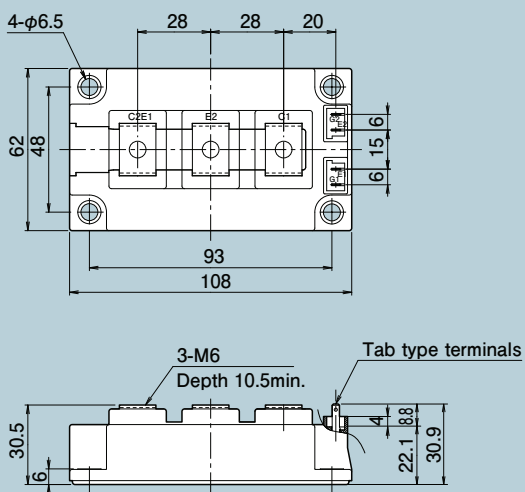

M277

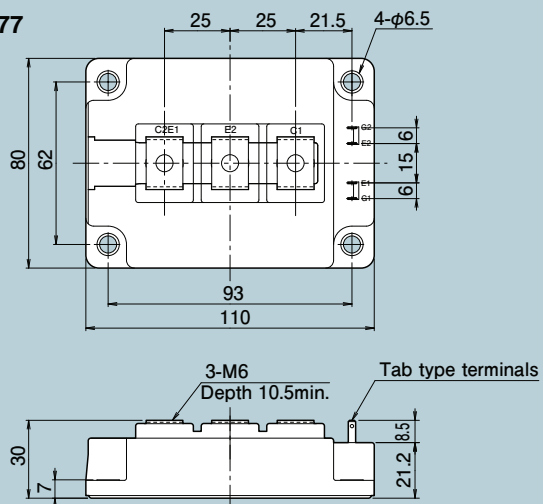

M278

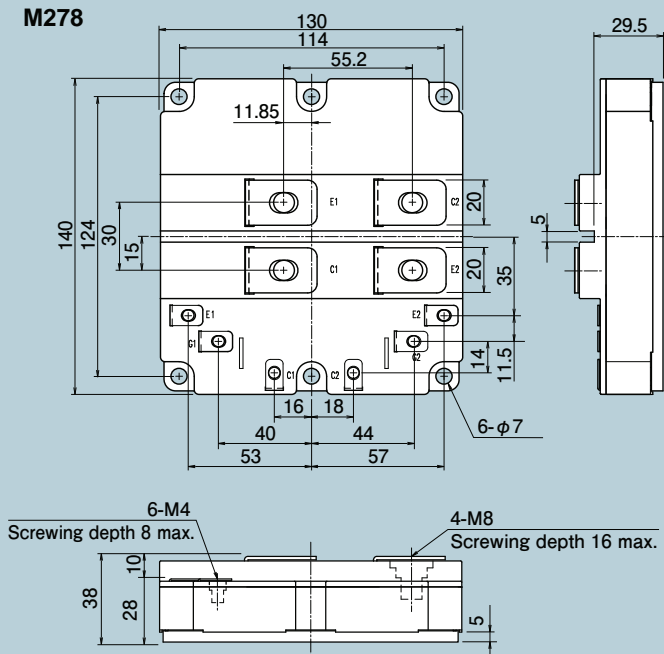

M282

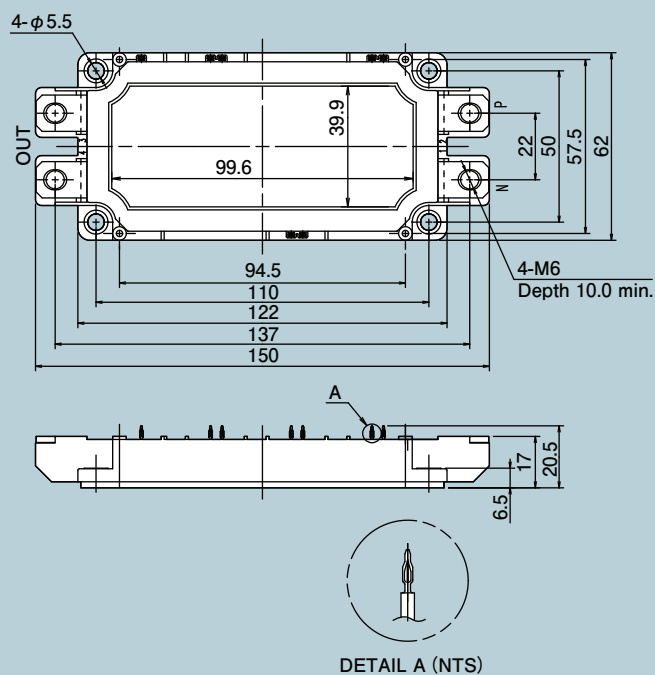

Unit: mm

M283

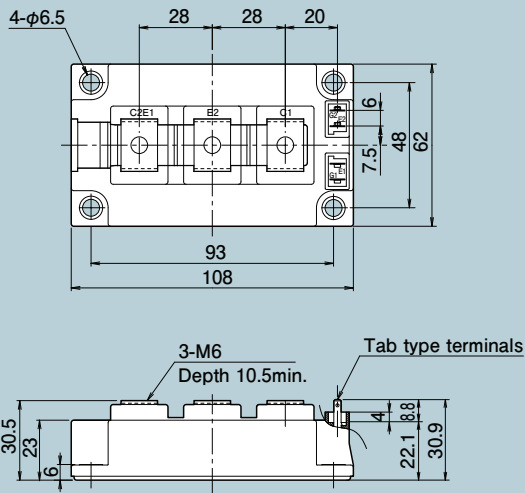

M285

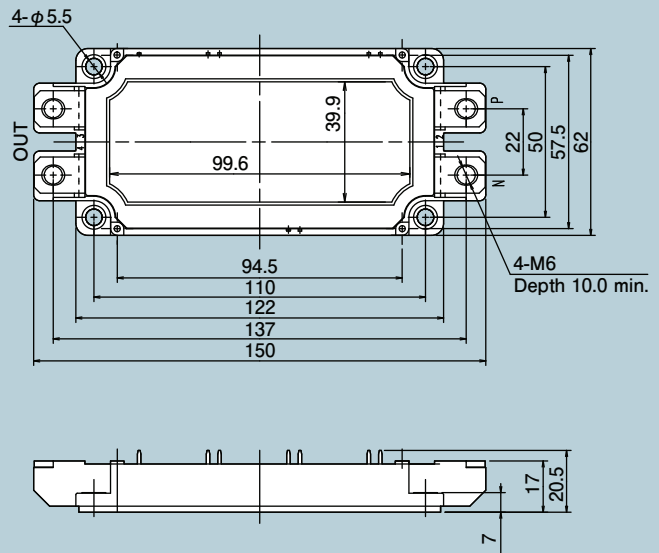

M286

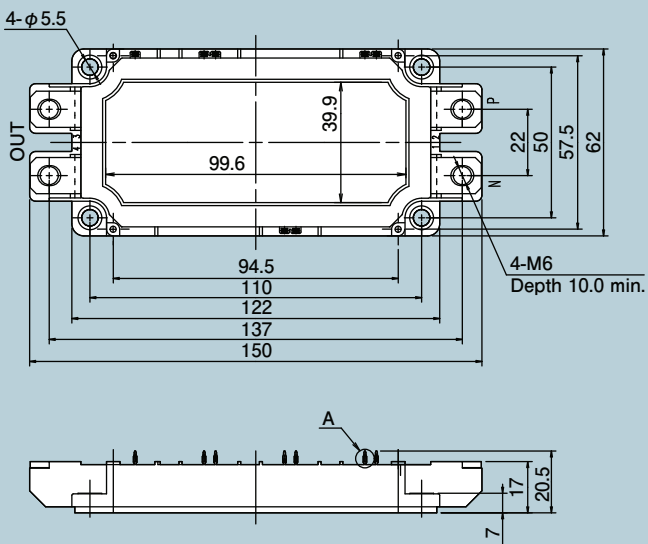

M288

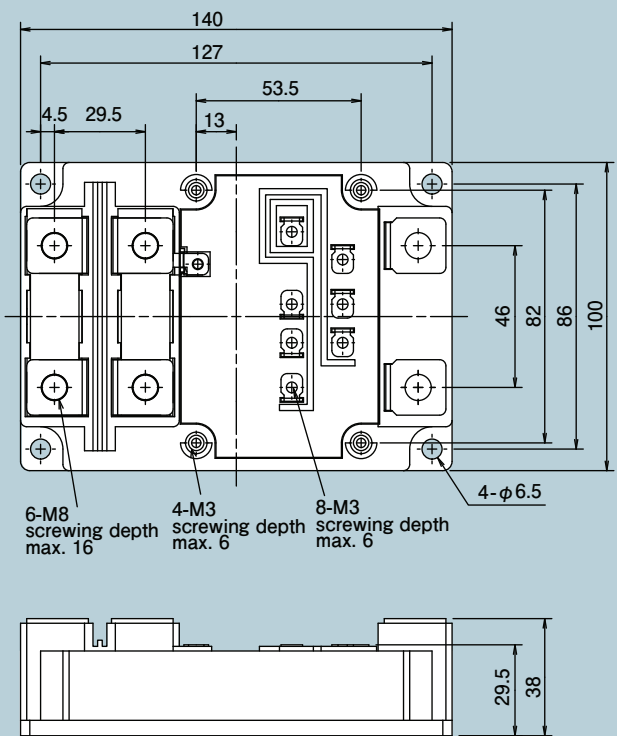

Unit: mm

M289

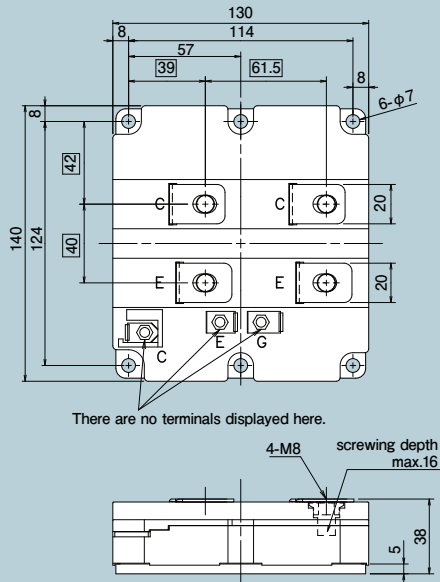

M292

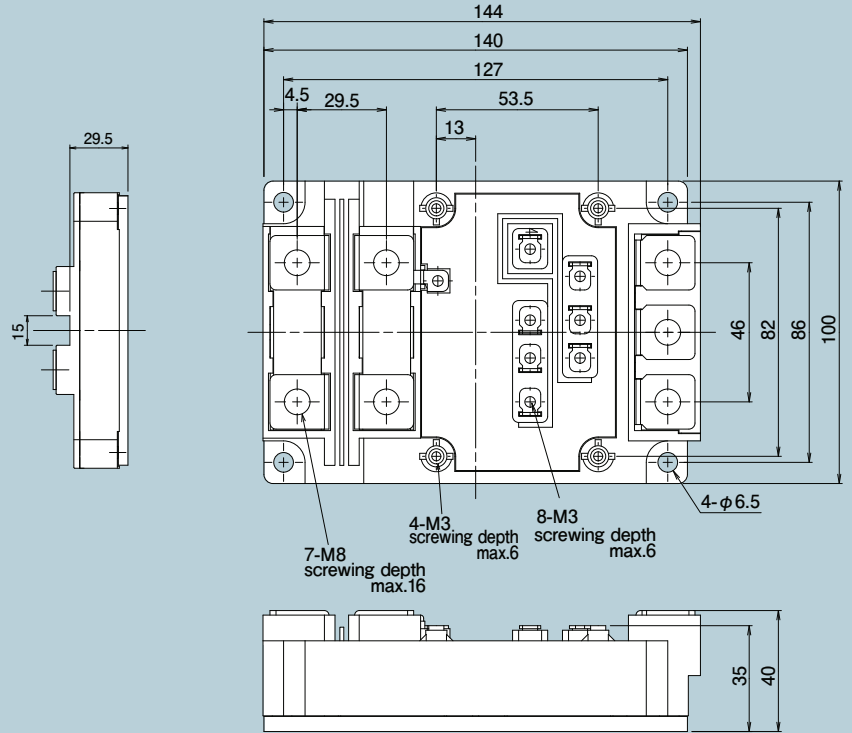

M403

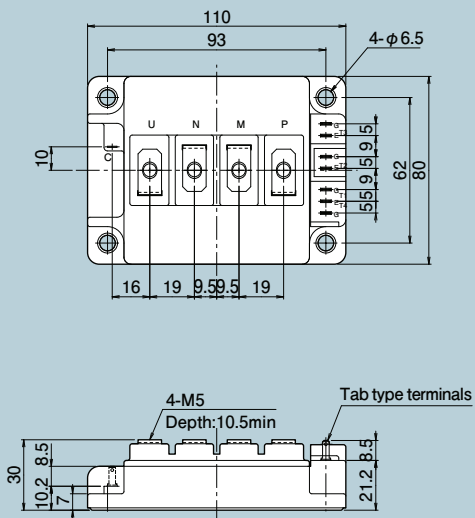

M404

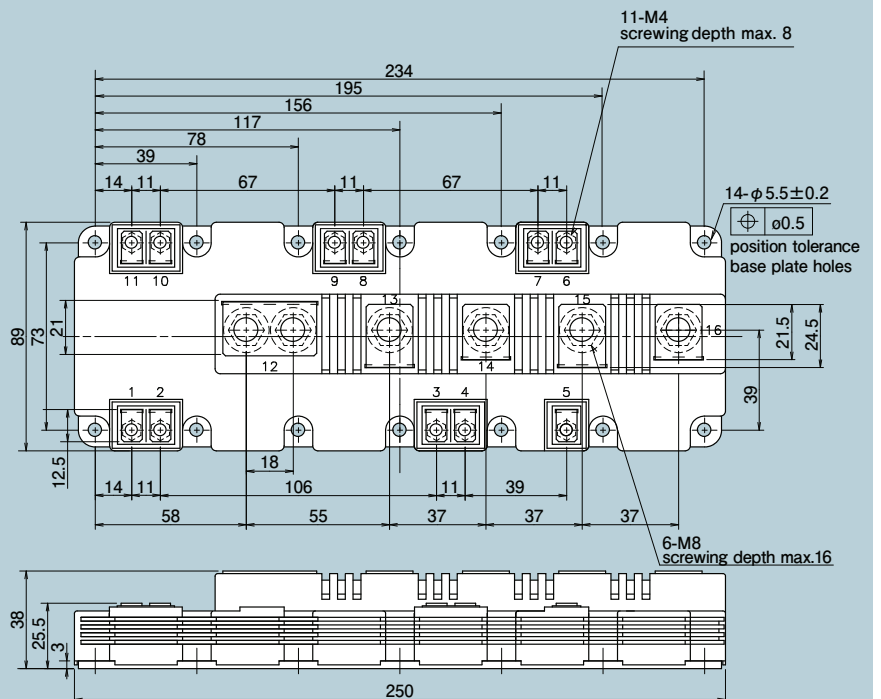

M629

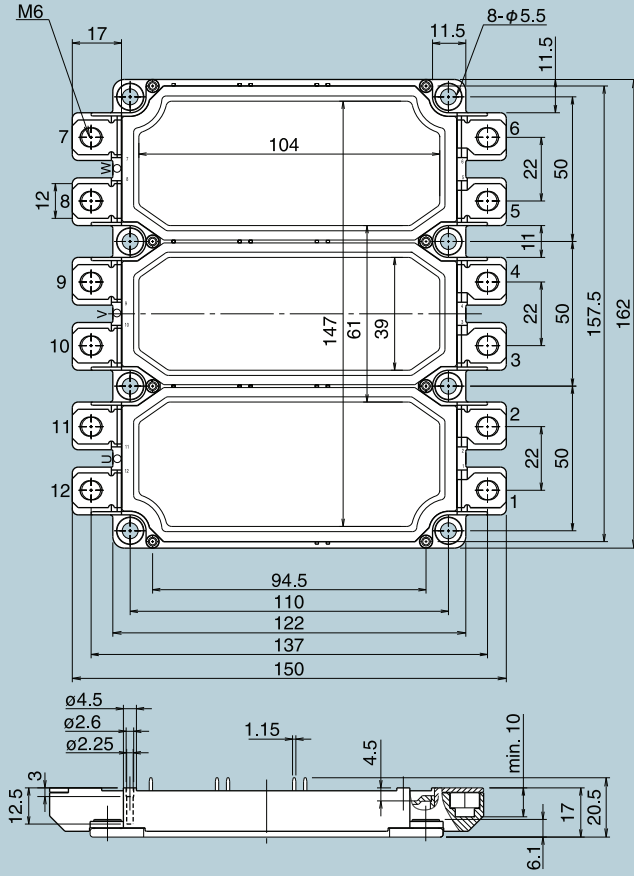

M633

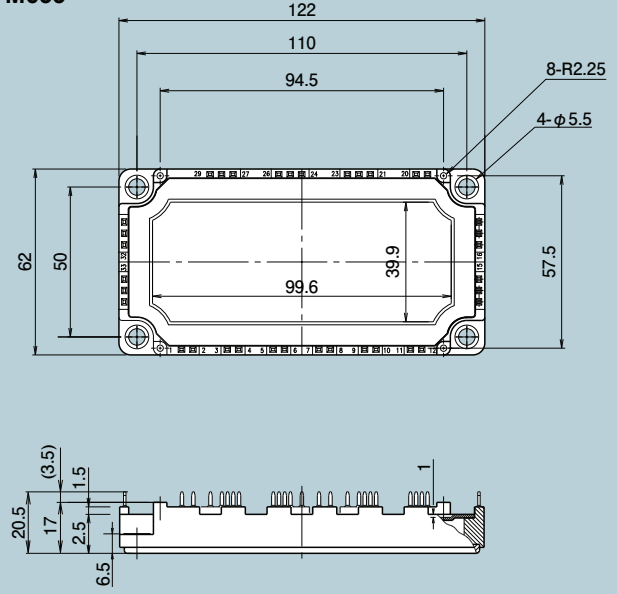

M636

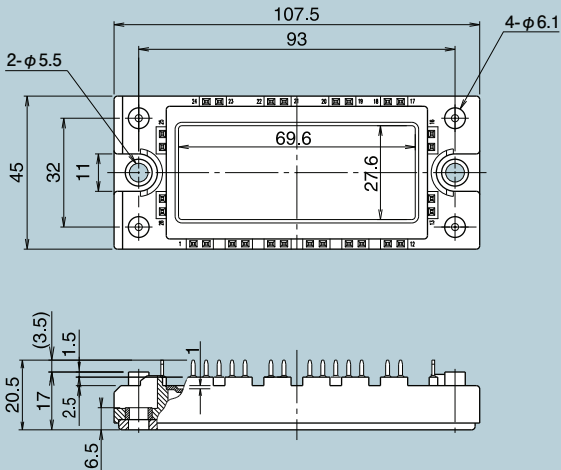

M647

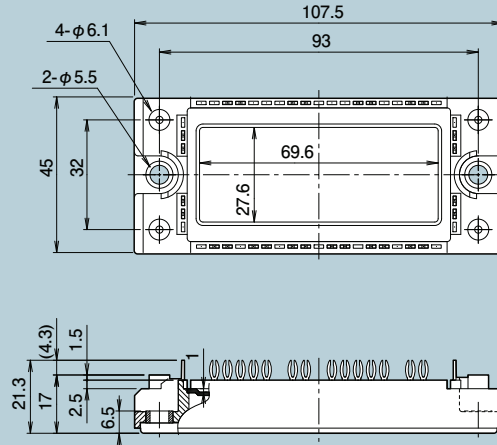

Unit: mm

M648

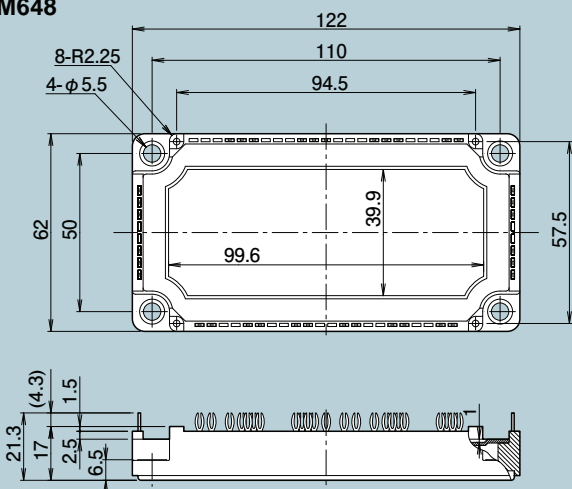

M653

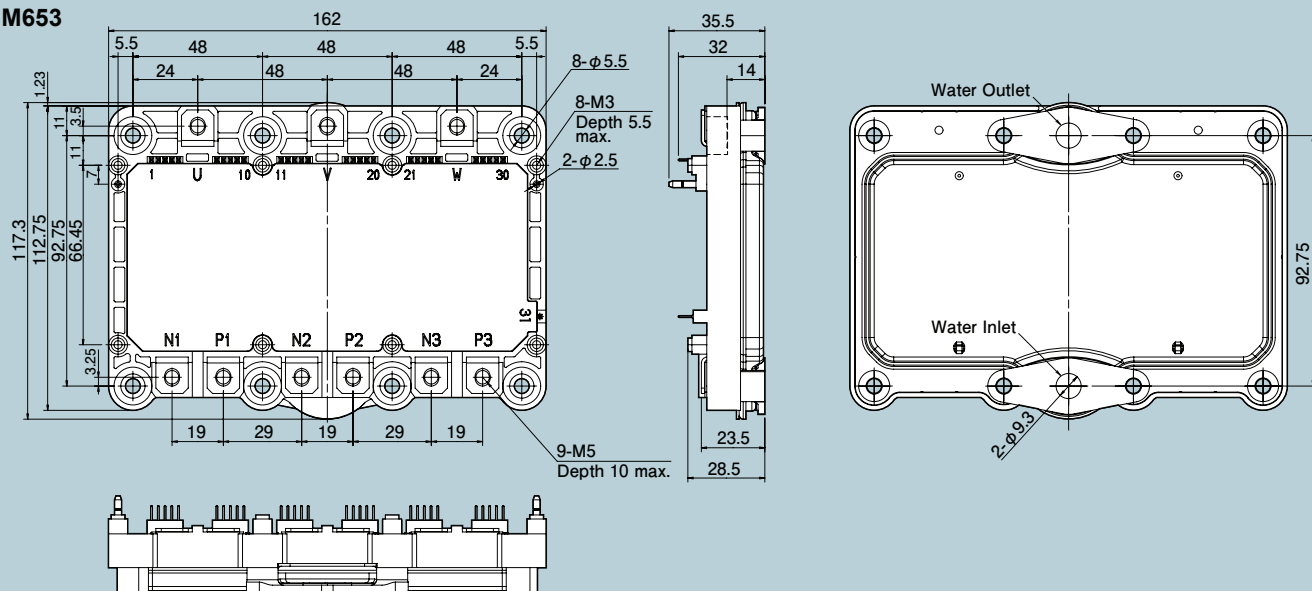

M668

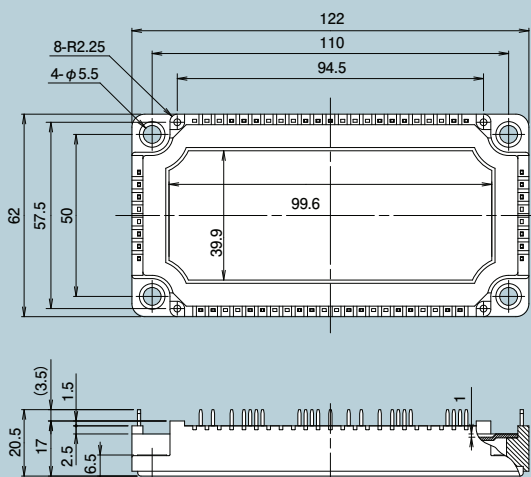

M669

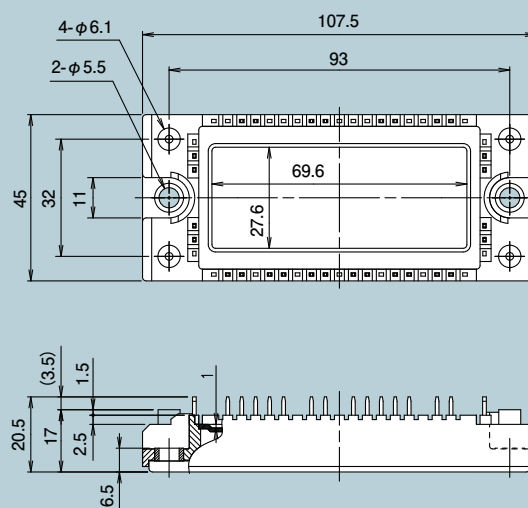

M711

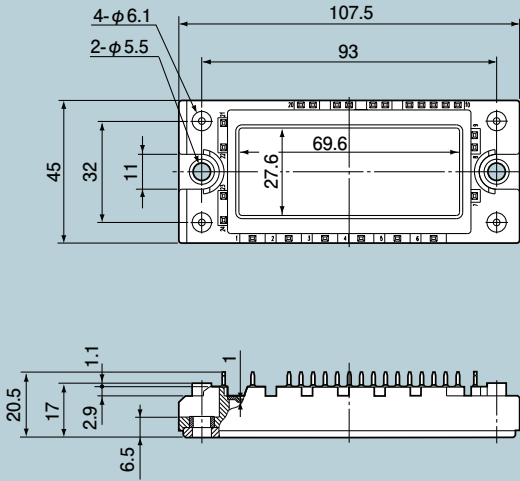

M712

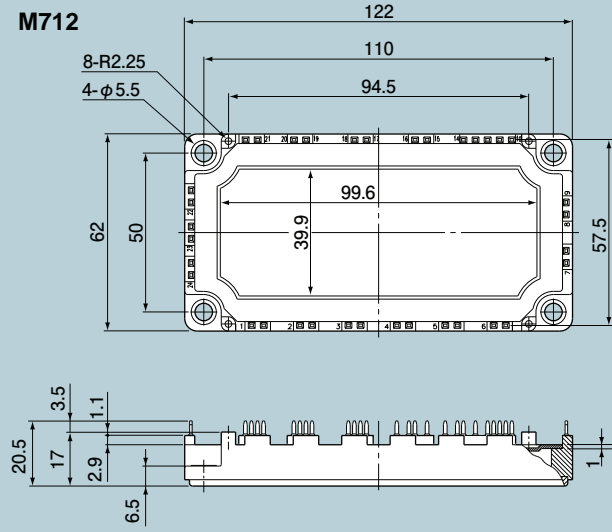

M719

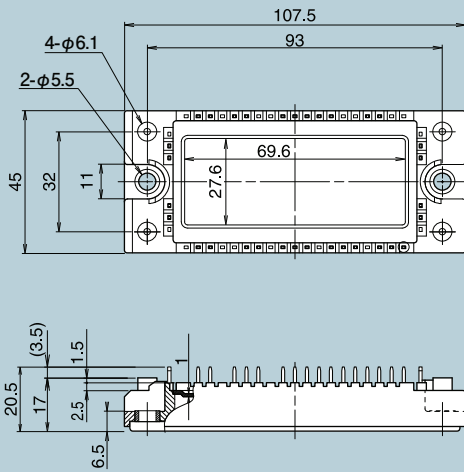

M720

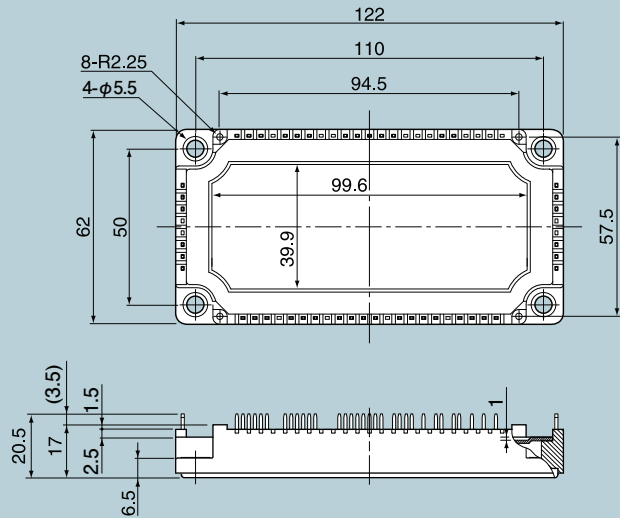

M721

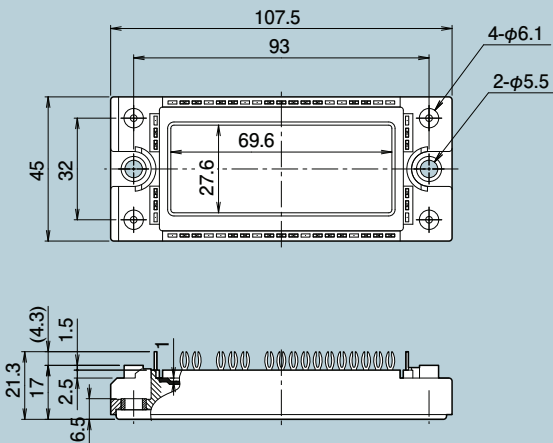

M722

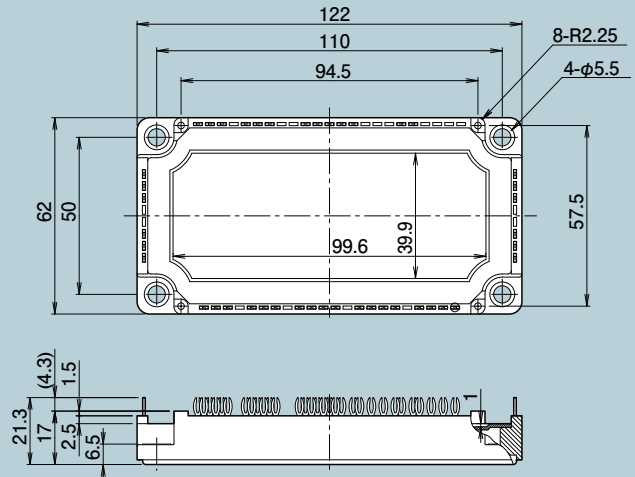

Unit: mm

M726

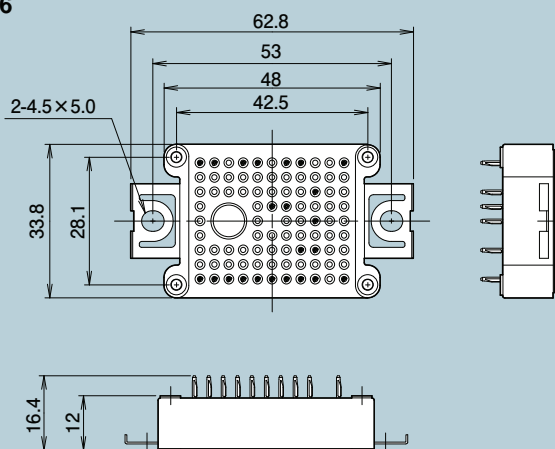

M727

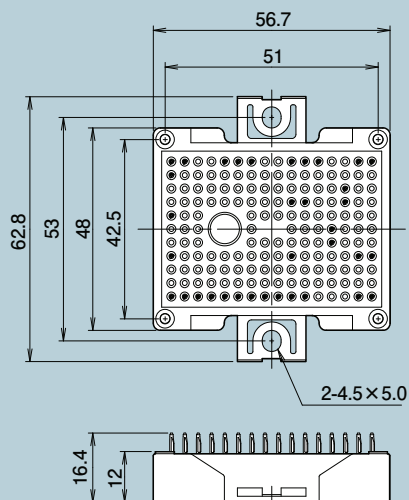

M728

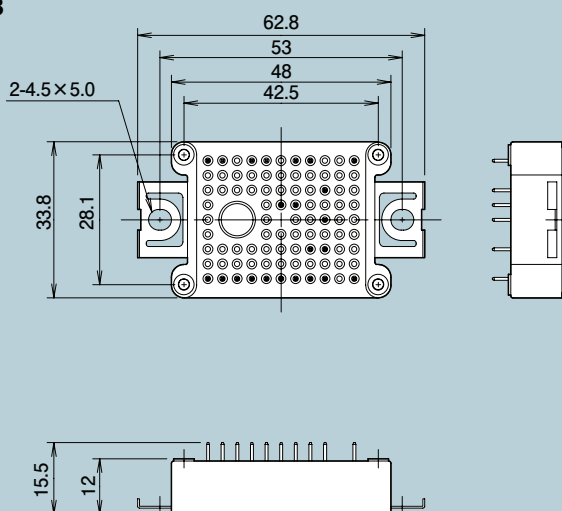

M729

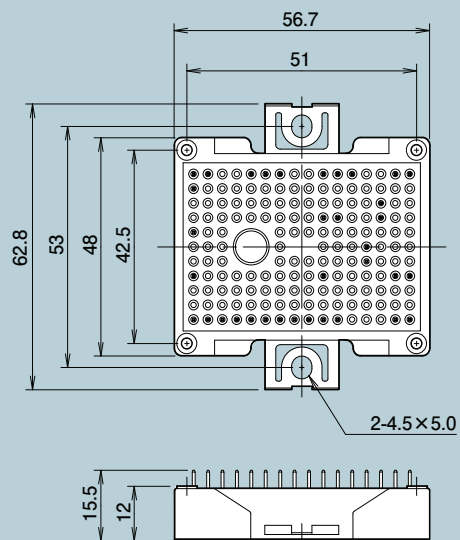

M730

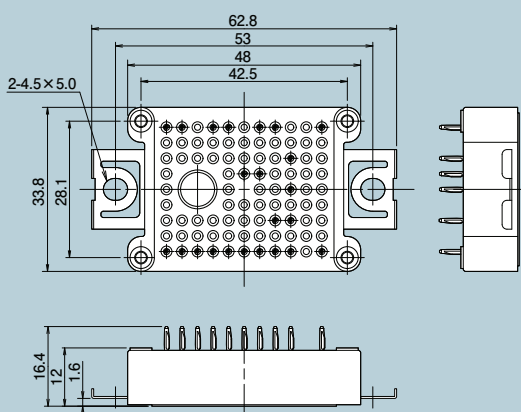

M731

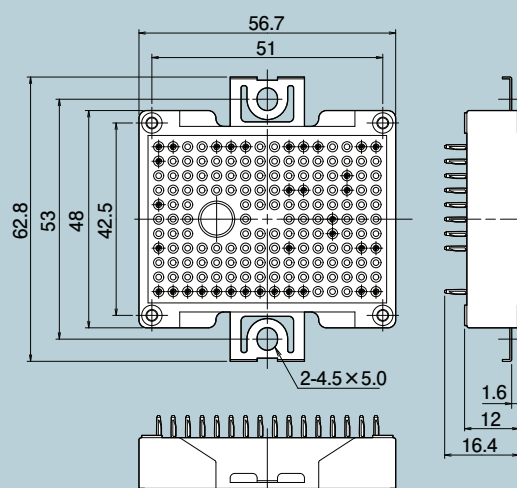

M732

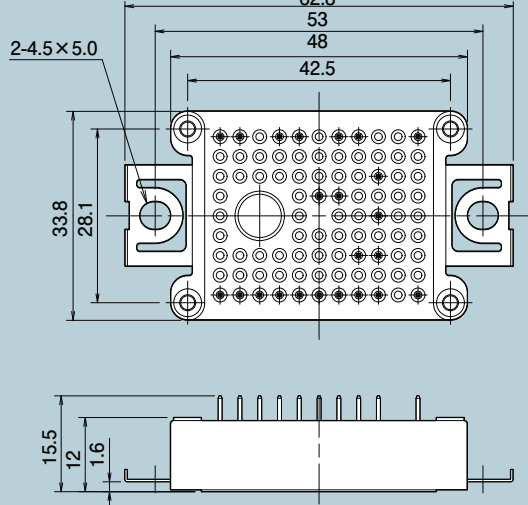

M733

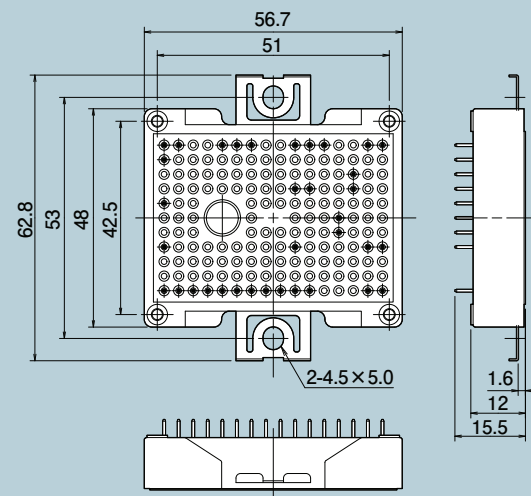

M1202

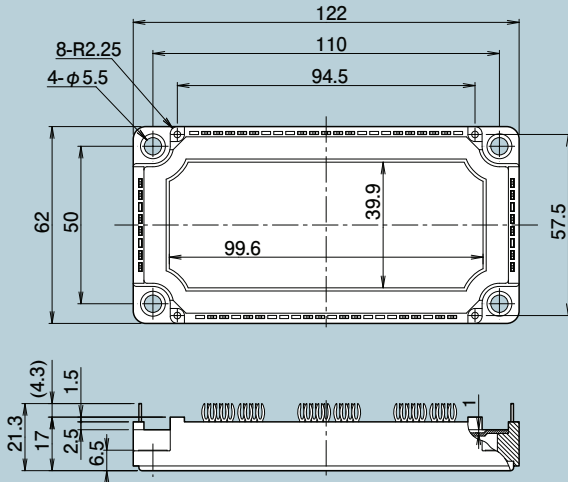

M1203

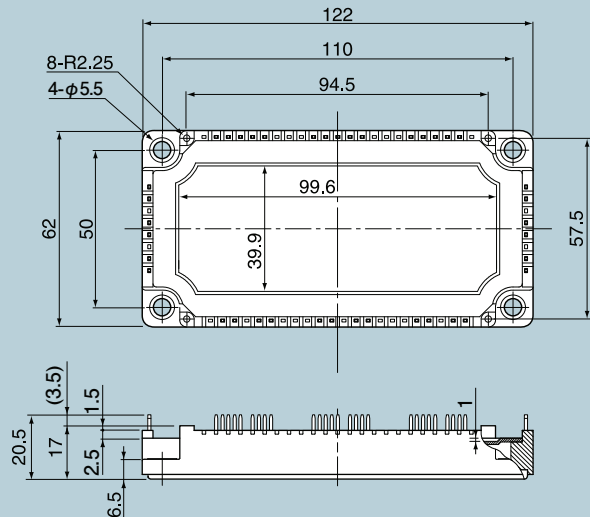

**P401
(EV, HEV)**

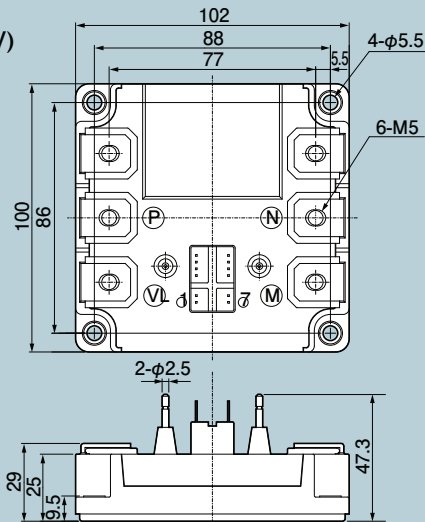

P626

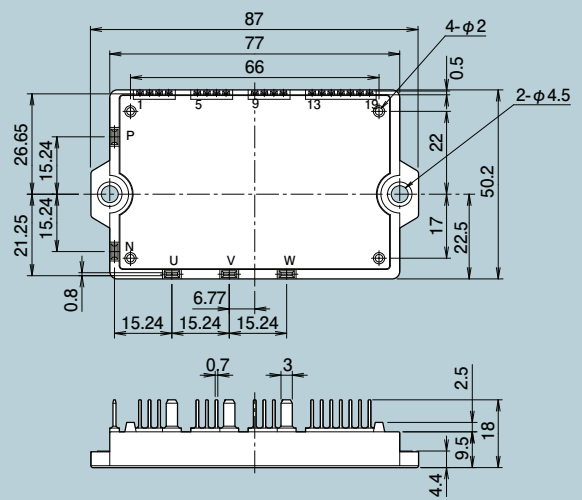

Unit: mm

P629

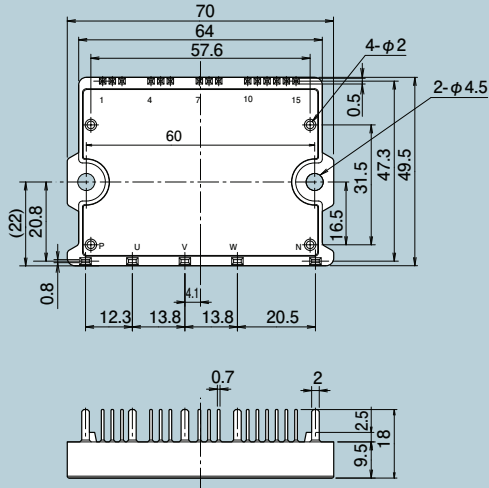

P630

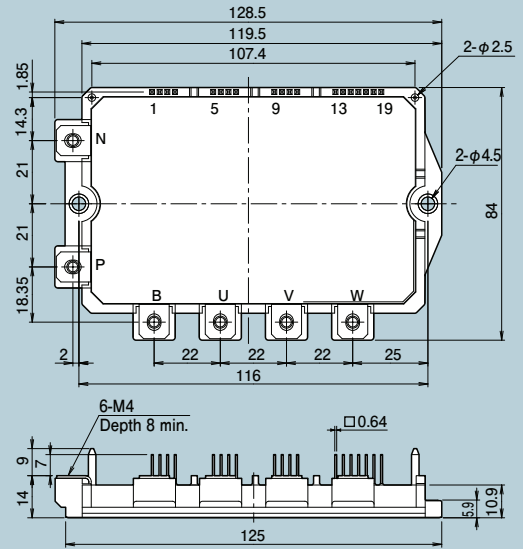

P631

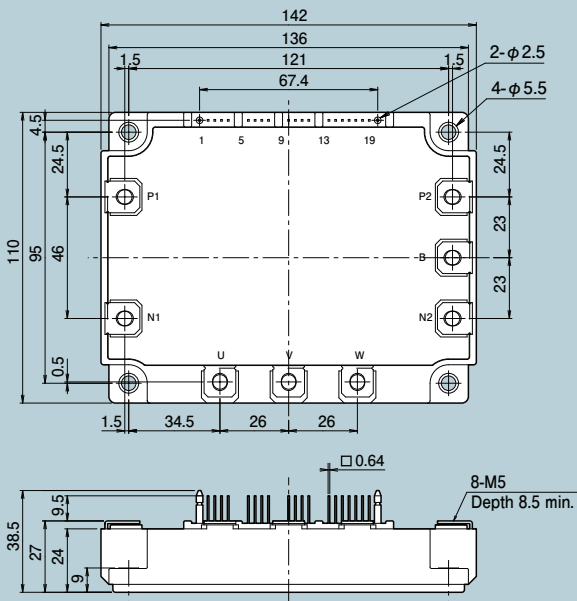

P636

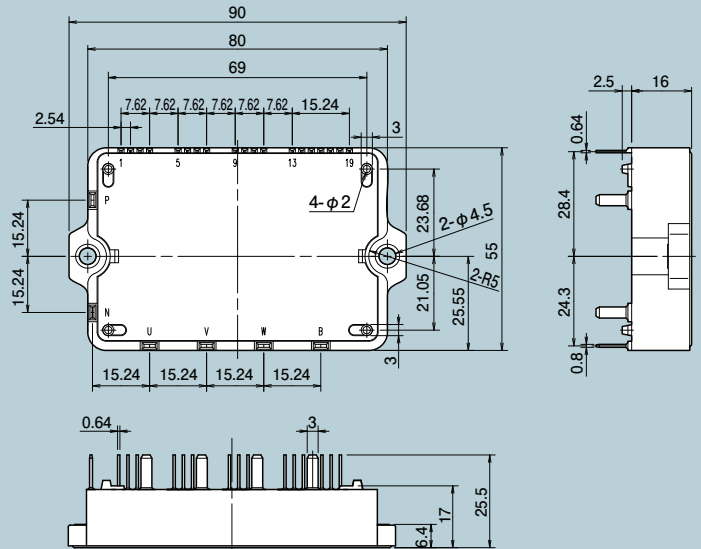

P633A

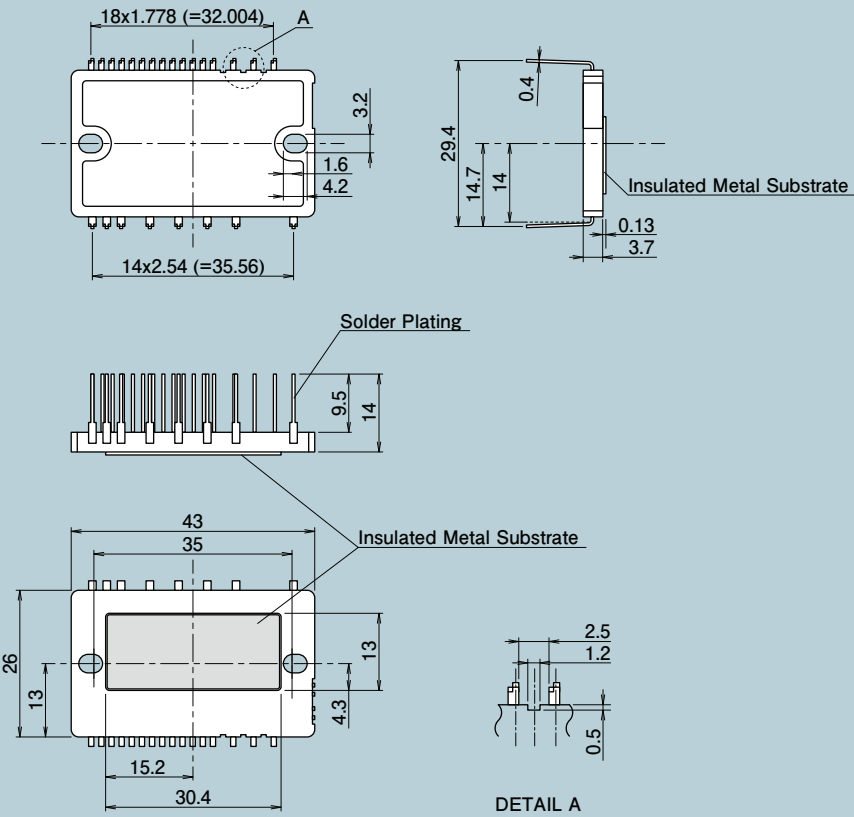

<Integrated circuits>

Unit: mm

SOP-8*1

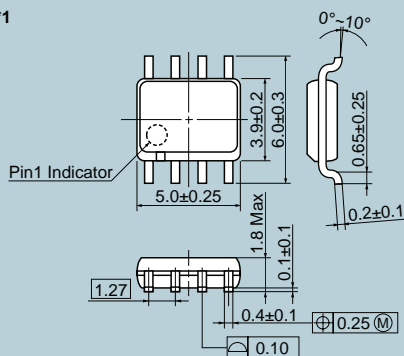

SOP-8E

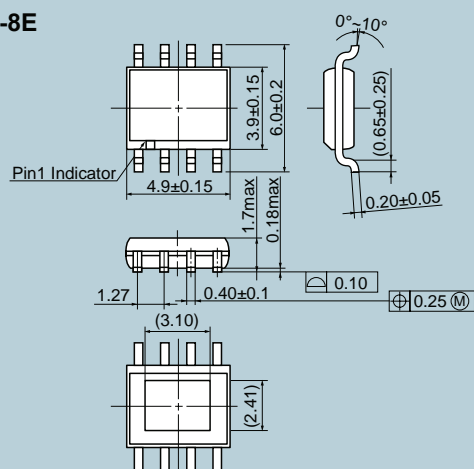

DIP-8

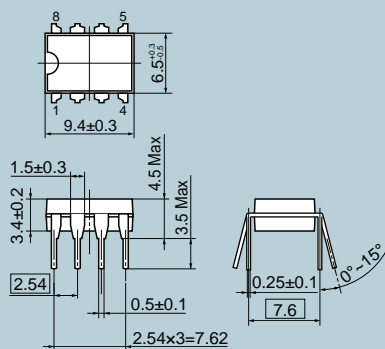

PSOP-12

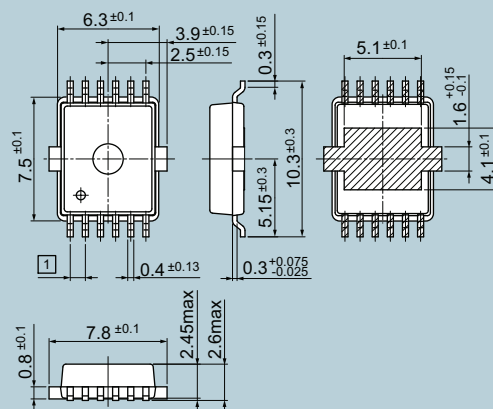

DIP-16

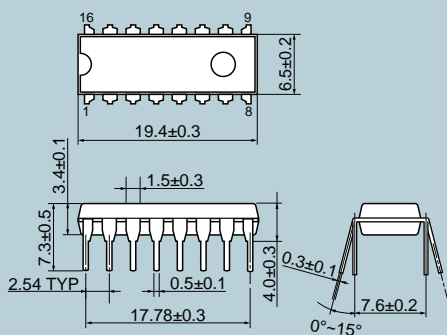

SOP-16(M)

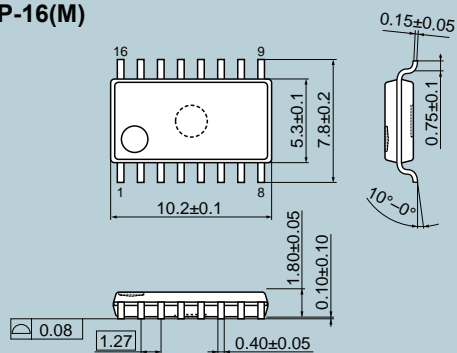

SOP-16(N)

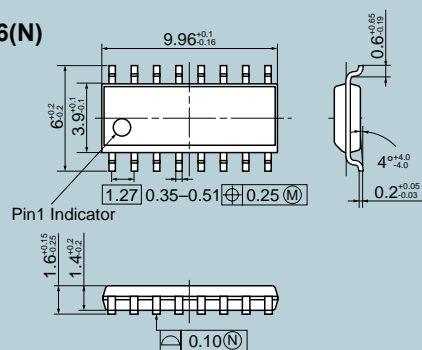

SSOP-20

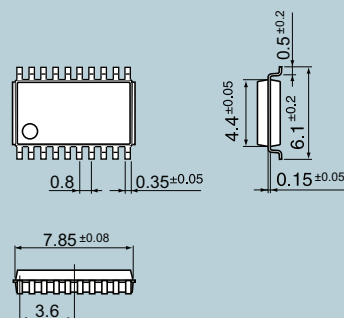

*1) This is the package size for the representative device type (FA8AxXN). For other ICs, please refer to the separate application note (specifications).

TSSOP-8

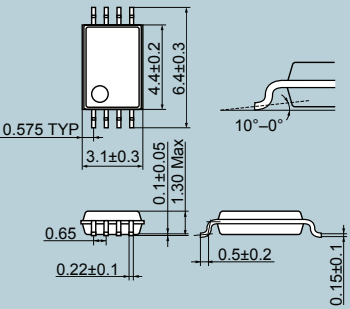

TSSOP-16

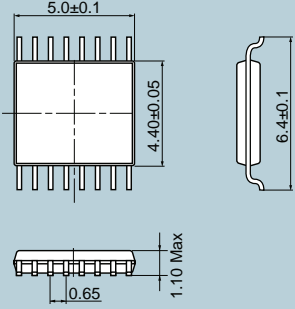

<Discrete devices>

Unit: mm

K-pack(S)

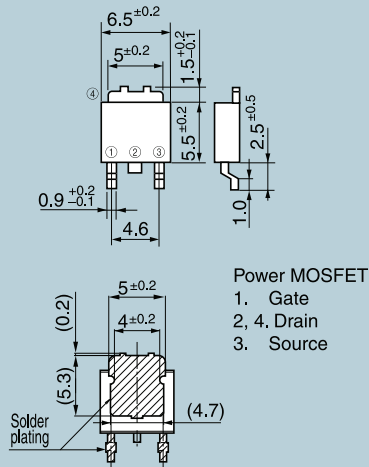

DFN8x8

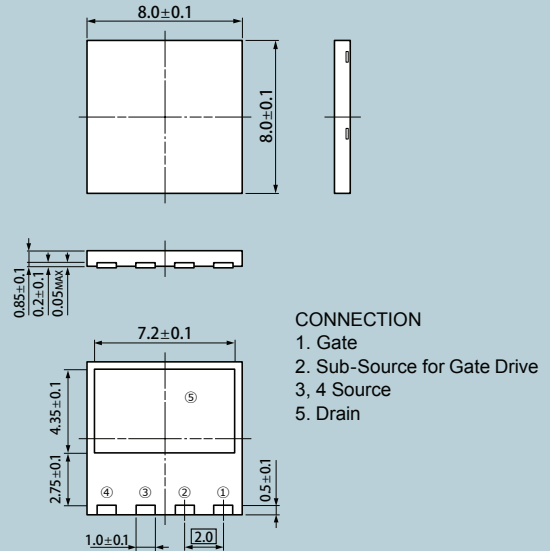

K-pack(L)/I-pack: Power MOSFET
K-pack(P)/I-pack: Diode

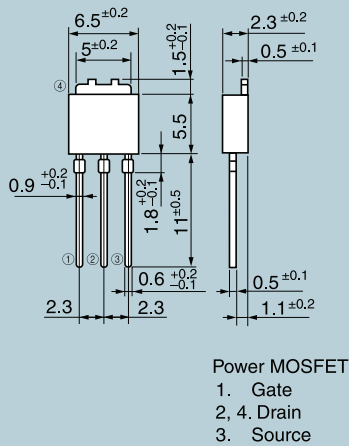

T-pack(S)

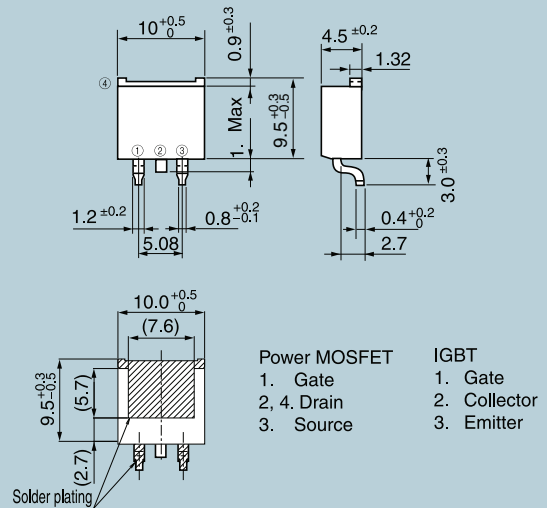

T-pack(L): Power MOSFET
T-pack(P): Diode

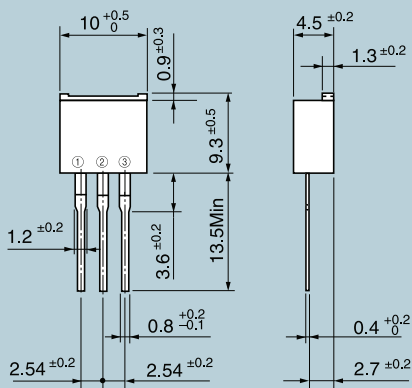

TFP

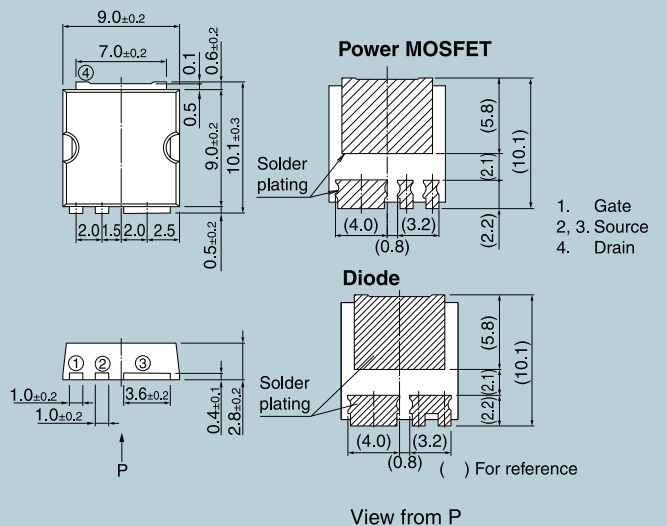

Unit: mm

D2-Pack

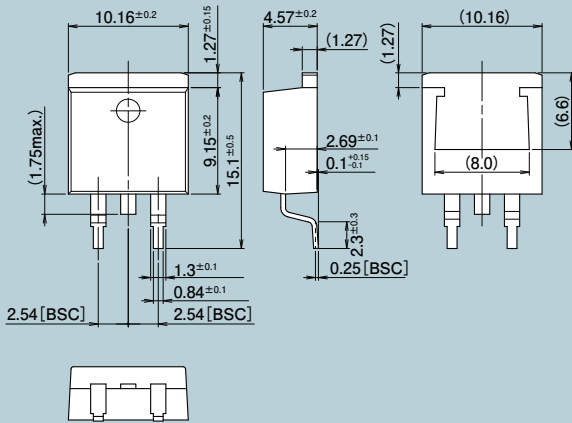

TO-220AB

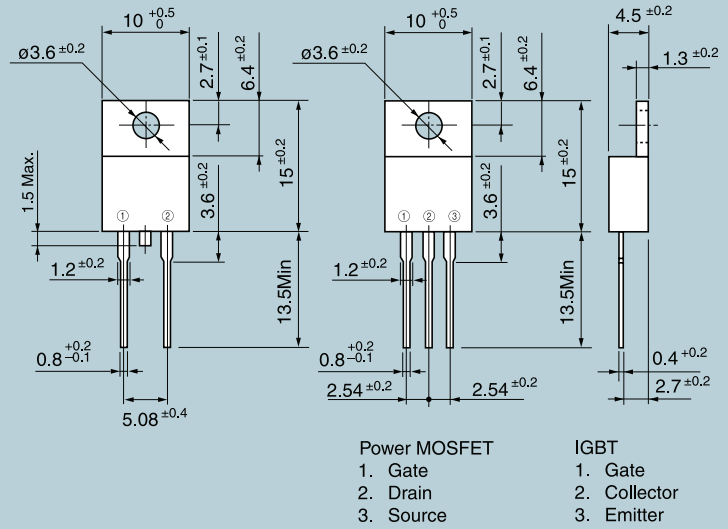

TO-220-2

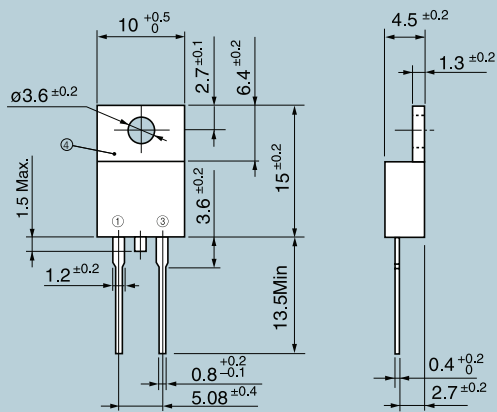

TO-220F

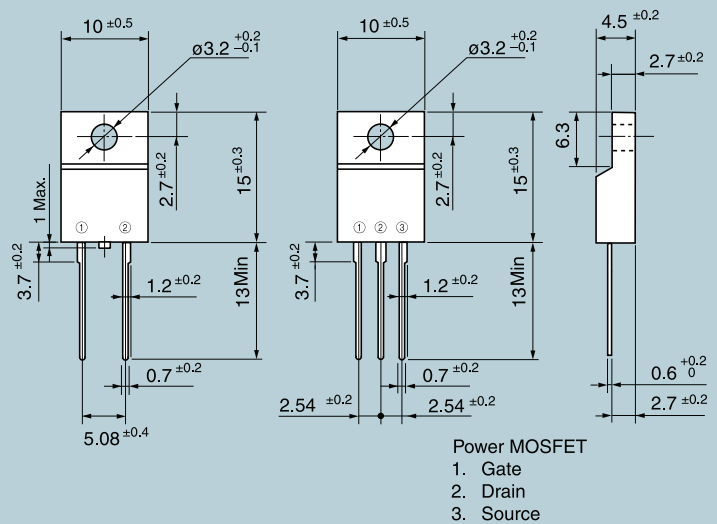

TO-220F (SLS)

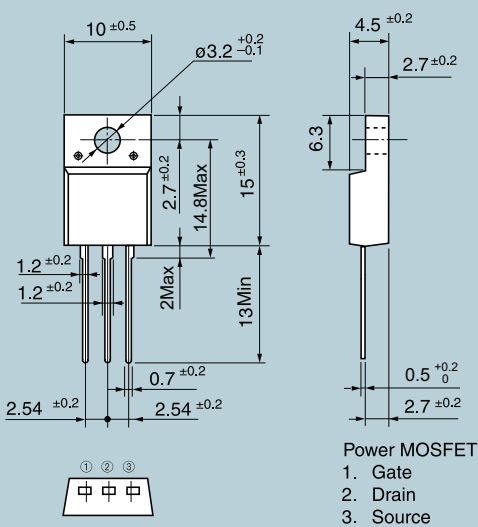

TO-220F-2

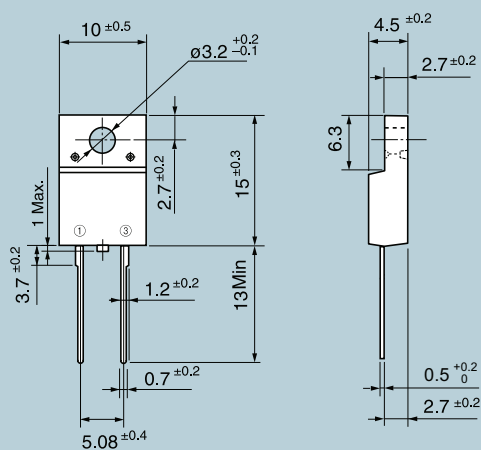

Unit: mm

TO-247

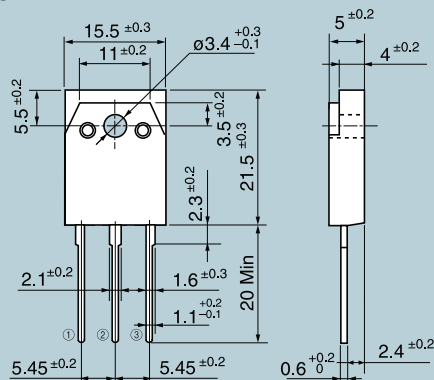

Power MOSFET

1. Gate
2. Drain
3. Source

TO-247-P2

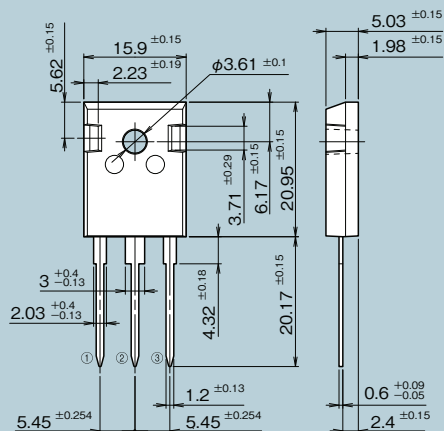

Power MOSFET

1. Gate
2. Drain
3. Source

IGBT

1. Gate
2. Collector
3. Emitter

FWD

1. Anode
2. Cathode
3. Anode

TO-247-2-P2

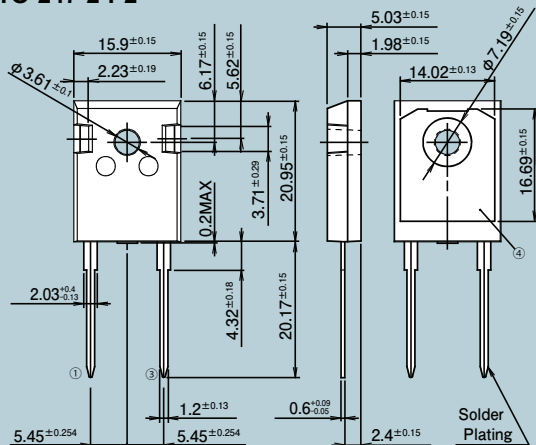

CONNECTION
①,④ CATHODE
③ ANODE

TO-247-2L-P2

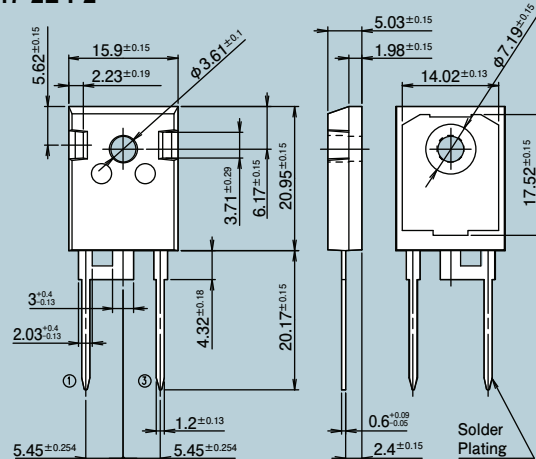

CONNECTION
① CATHODE
③ ANODE

TO-247-4-P2

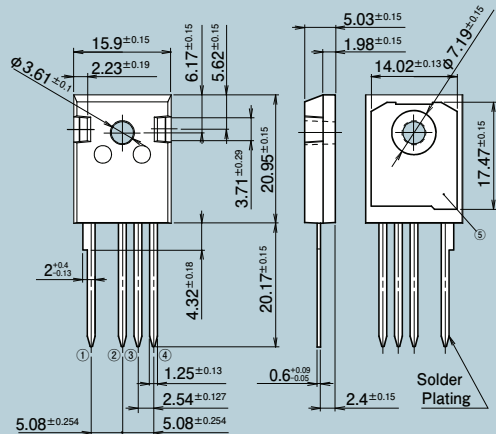

CONNECTION
①⑤
④②
③④
1. COLLECTOR
2. EMITTER
3. SUB EMITTER
4. GATE

TO-3P

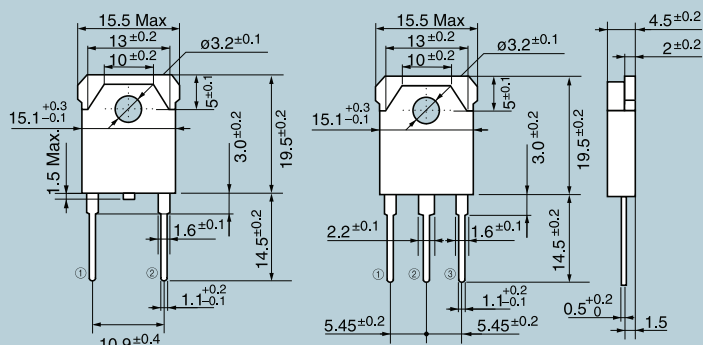

Power MOSFET

1. Gate
2. Drain
3. Source

IGBT

1. Gate
2. Collector
3. Emitter

TO-3P(Q)

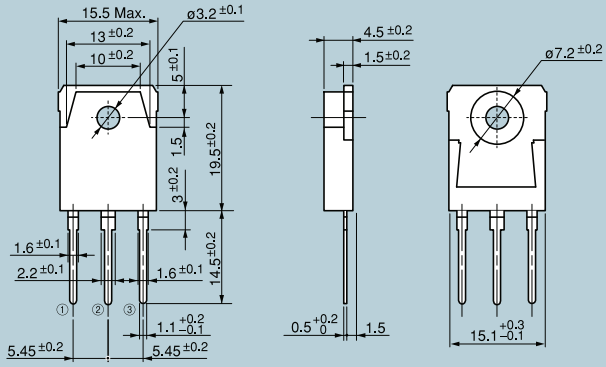

Power MOSFET

1. Gate
2. Drain
3. Source

TO-3PF

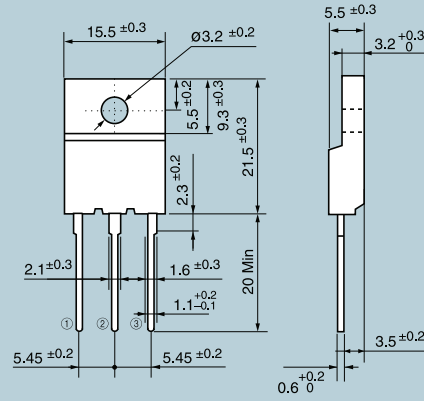

Power MOSFET

1. Gate
2. Drain
3. Source

Order Quantity

- Order unit is the number in “Min. quantity per order” or its integral multiplication.
- This table covers single or reel package items (Except for taping items).
- Order unit of taping package is different for each specification.
Please contact us for more detail.

Products	Package	Type number	Min. quantity per order	Min. quantity per packing
Power MOSFETs Diodes	TO-220	All types	100	500
	TO-220F/TO-220F(SLS)		100	500
	TO-220F-2		1,000	1,000
	TO-247		100	500
	TO-247-2-P2		600	600
	TO-247-4-P2		600	600
	TO-247-2L-P2		600	600
	TO-3P, TO-3P(Q)		100	500
	TO-3PF		100	500
	TO-3PL		50	50
	TFP		1,500	1,500
	K-pack (S)		3,000	3,000
	T-pack (S)		1,000	1,000
	K-pack (L, P)		500	500
	T-pack (L, P)		100	500
	DFN8x8			3,000
TO-220		-S2□PP (Tube)	1,000	1,000
TO-220F		-S3□PP (Tube)	1,000	1,000
Power MOSFETs Discrete IGBTs Diodes	TO-247-P2	All types	600	600
ICs		All types (except for below types)	2,000	2,000
		FA8A-□□, FA6A-□□, FA1A-□□	3,000	3,000
		FA5627, 28	3,000	3,000
		FA5637	3,000	3,000
		FA5641, 42, 43, 44	3,000	3,000
		FA5680, FA5681	3,000	3,000
		FA5696	3,000	3,000
		FA5651	3,000	3,000
		FA5752	3,000	3,000
		FA5760	3,000	3,000

Type Number Index

	Page		Page		Page		Page		Page		Page
12MBI100VN-120-50	41	1MBI400V-170-50	34	2MBI1400VB-120P-54	32	2MBI300VD-120-50	24	2MBI450VN-120S-50	27	2MBI600XNH120-50	26
12MBI100VX-120-50	41	1MBI400VF-120-50	34	2MBI1400VB-120P-80	32	2MBI300VE-120-50	24	2MBI450VN-120S-80	27	2MBI600XNH170-50	28
12MBI50VN-120-50	41	1MBI400VH-060L-50	36	2MBI1400VB-170E-50	33	2MBI300VE-120-80	24	2MBI450VN-170-50	29	2MBI650VXA-170E-50	33
12MBI50VX-120-50	41	1MBI50U4F-120L-50	36	2MBI1400VB-170E-54	33	2MBI300VE-170-50	25	2MBI450VN-170-80	29	2MBI650VXA-170E-54	33
12MBI75VN-120-50	41	1MBI600V-120-50	34	2MBI1400VB-170E-80	33	2MBI300VE-170-80	25	2MBI450VX-120-50	27	2MBI650VXA-170E-80	33
12MBI75VX-120-50	41	1MBI600V-170-50	34	2MBI1400VB-170P-50	33	2MBI300VH-120-50	24	2MBI450VX-120-80	27	2MBI650VXA-170E-50	33
1MBI1000UG-330	35	1MBI600VF-120-50	34	2MBI1400VB-170P-54	33	2MBI300VH-120-80	24	2MBI450VX-170-50	29	2MBI650VXA-170E-54	33
1MBI1000UG-330B	35	1MBI650VXA-170EH-50	37	2MBI1400VB-170P-80	33	2MBI300VH-170-50	25	2MBI450VX-170-80	29	2MBI650VXA-170E-80	33
1MBI1000VB-170EH-50	37	1MBI650VXA-170EH-54	37	2MBI1400XXB120P-50	32	2MBI300VH-170-80	25	2MBI450XEE120-50	23	2MBI650XXA170-50	33
1MBI1000VB-170EH-54	37	1MBI650VXA-170EH-80	37	2MBI1400XXB170-50	33	2MBI300VJ-120-50	27	2MBI450XHA120-50	23	2MBI75VA-120-50	24
1MBI1000VB-170EH-80	37	1MBI650VXA-170EL-50	37	2MBI150HH-120-50	39	2MBI300VJ-120-80	27	2MBI450XNA120-50	26	2MBI75VA-170-50	25
1MBI1000VB-170EL-50	37	1MBI650VXA-170EL-54	37	2MBI150HJ-120-50	39	2MBI300VN-120-50	27	2MBI450XNA170-50	28	2MBI75XAA170-50	25
1MBI1000VB-170EL-54	37	1MBI650VXA-170EL-80	37	2MBI150VA-060-50	22	2MBI300VN-120-80	27	2MBI450XNB120-50	26	2MBI800VG-120P	31
1MBI1000VB-170EL-80	37	1MBI75U4F-120L-50	36	2MBI150VA-120-50	24	2MBI300VN-120S-50	27	2MBI450XNB170-50	28	2MBI800VG-170E	31
1MBI100U4F-120L-50	36	1MBI800UG-330	35	2MBI150VB-120-50	24	2MBI300VN-120S-80	27	2MBI450XUF330-50	30	2MBI800VT-170E	31
1MBI1200UE-330	35	1MBI900V-120-50	34	2MBI150VH-170-50	25	2MBI300VN-170-50	29	2MBI450XVF330-50	30	2MBI800XNE120-50	26
1MBI1200VC-120P	35	1MBI900VXA-120PC-50	38	2MBI150VH-170-80	25	2MBI300VN-170-80	29	2MBI550VJ-170-50	29	2MBI800XNF120-50	26
1MBI1200VC-170E	35	1MBI900VXA-120PC-54	38	2MBI150XAA065-50	22	2MBI300VX-120-50	27	2MBI550VJ-170-80	29	2MBI900VXA-120E-50	32
1MBI1200VR-170E	35	1MBI900VXA-120PC-80	38	2MBI150XAA120-50	23	2MBI300VX-120-80	27	2MBI550VN-170-50	29	2MBI900VXA-120E-54	32
1MBI1400VB-120PH-54	37	1MBI900VXA-120PD-50	38	2MBI150XAA170-50	25	2MBI300VX-170-50	29	2MBI550VN-170-80	29	2MBI900VXA-120E-80	32
1MBI1400VB-120PH-80	37	1MBI900VXA-120PD-54	38	2MBI150XHA170-50	25	2MBI300VX-170-80	29	2MBI550VX-170-50	29	2MBI900VXA-120P-50	32
1MBI1400VB-120PL-54	37	1MBI900VXA-120PD-80	38	2MBI1800XF120P-50	32	2MBI300XBE065-50	22	2MBI550VX-170-80	29	2MBI900VXA-120P-54	32
1MBI1400VB-120PL-80	37	1MSI1200XAGF330-03	53	2MBI1800XF170-50	33	2MBI300XBE120-50	23	2MBI600VD-060-50	22	2MBI900VXA-120P-80	32
1MBI1400VB-170PH-50	37	1MSI1800XAEF330-03	53	2MBI200HH-120-50	39	2MBI300XEE170-50	25	2MBI600VE-060-50	22	2MBI900XXA120E-50	32
1MBI1400VB-170PH-54	37	2MBI1000VB-170E-50	33	2MBI200HJ-120-50	39	2MBI300XHA120-50	23	2MBI600VE-060-80	22	2MBI900XXA120P-50	32
1MBI1400VB-170PL-50	37	2MBI1000VB-170E-54	33	2MBI200VA-060-50	22	2MBI300XHA170-50	25	2MBI600VE-120-50	24	2MBP600UN120V	49
1MBI1400VB-170PL-54	37	2MBI1000VB-170E-80	33	2MBI200VB-120-50	24	2MBI300XNA120-50	26	2MBI600VE-120-80	24	2MSI1200VAT-170EC	52
1MBI1500UE-330	35	2MBI1000VB-170EA-50	33	2MBI200VH-120-50	24	2MBI300XNA170-50	28	2MBI600VG-120P	31	2MSI1200VAT-170PC	52
1MBI1500UE-330B	35	2MBI1000VB-170EA-54	33	2MBI200VH-120-80	24	2MBI300XNB120-50	26	2MBI600VG-170E	31	2MSI200VAB-120-53	52
1MBI150VA-120L-50	36	2MBI1000VB-170EA-80	33	2MBI200VH-170-50	25	2MBI300XNB170-50	28	2MBI600VJ-120-50	27	2MSI300VAH-120C-53	52
1MBI1600VC-120P	35	2MBI1000XUF170-50	30	2MBI200VH-170-80	25	2MBI400VB-060-50	22	2MBI600VJ-120-80	27	2MSI300VAN-120-53	52
1MBI1600VC-170E	35	2MBI1000XVF170-50	30	2MBI200XAA065-50	22	2MBI400VD-060-50	22	2MBI600VN-120-50	27	2MSI400VAE-170-53	52
1MBI1600VR-170E	35	2MBI1000XXB170-50	33	2MBI200XAA120-50	23	2MBI400VD-120-50	24	2MBI600VN-120-80	27	2MSI450VAN-120-53	52
1MBI200HH-120L-50	39	2MBI100HB-120-50	39	2MBI200XBE120-50	23	2MBI400VE-170-50	25	2MBI600VT-170E	31	2MSI550VAN-170-53	52
1MBI200U4H-120L-50	36	2MBI100HJ-120-50	39	2MBI200XHA170-50	25	2MBI400VE-170-80	25	2MBI600VX-120-50	27	2MSI600VAN-120-53	52
1MBI200VA-120L-50	36	2MBI100VA-060-50	22	2MBI225VJ-120-50	27	2MBI400XBE065-50	22	2MBI600VX-120-80	27	2SI900AGF330-03	54
1MBI2400VC-120P	35	2MBI100VA-120-50	24	2MBI225VJ-120-80	27	2MBI400XDE065-50	22	2MBI600VXA-120E-50	32	2SK3270-01	90
1MBI2400VC-170E	35	2MBI100VA-170-50	25	2MBI225VN-120-50	27	2MBI400XDE120-50	23	2MBI600VXA-120E-54	32	2SK3270-01	94
1MBI2400VD-120P	35	2MBI100XAA120-50	23	2MBI225VN-120-80	27	2MBI400XEE170-50	25	2MBI600VXA-120E-80	32	2SK3271-01	90
1MBI2400VD-170E	35	2MBI100XAA170-50	25	2MBI225VN-120S-50	27	2MBI400XHA170-50	25	2MBI600XDE065-50	22	2SK3271-01	94
1MBI2400VR-170E	35	2MBI1200VG-120P	31	2MBI225VX-120-50	27	2MBI450VE-120-50	24	2MBI600XDE120-50	23	2SK3272-01L, S	90
1MBI2400VS-170E	35	2MBI1200VG-170E	31	2MBI225VX-120-80	27	2MBI450VE-120-80	24	2MBI600XEE065-50	22	2SK3272-01L, S	94
1MBI300HH-120L-50	39	2MBI1200VT-170E	31	2MBI225VX-170-50	29	2MBI450VH-120-50	24	2MBI600XEE120-50	23	2SK3272-01S.J	90
1MBI300U2H-060L-50	36	2MBI1200XXE120E-50	32	2MBI225VX-170-80	29	2MBI450VH-120-80	24	2MBI600XHA120-50	23	2SK3272-01S.J	94
1MBI300V-170-50	34	2MBI1200XXE120P-50	32	2MBI225XNA120-50	26	2MBI450VH-120F-50	24	2MBI600XNE120-50	26	2SK3273-01MR	90
1MBI3600VD-120P	35	2MBI1200XXE170-50	33	2MBI225XNA170-50	28	2MBI450VH-120F-80	24	2MBI600XNE170-50	28	2SK3273-01MR	94
1MBI3600VD-170E	35	2MBI1400VB-120E-50	32	2MBI225XNB120-50	26	2MBI450VJ-120-50	27	2MBI600XNF120-50	26	2SK3450-01	88
1MBI3600VS-170E	35	2MBI1400VB-120E-54	32	2MBI225XNB170-50	28	2MBI450VJ-120-80	27	2MBI600XNF170-50	28	2SK3451-01MR	88
1MBI400HH-120L-50	39	2MBI1400VB-120E-80	32	2MBI300HJ-120-50	39	2MBI450VN-120-50	27	2MBI600XNG120-50	26	2SK3468-01	87
1MBI400V-120-50	34	2MBI1400VB-120P-50	32	2MBI300VB-060-50	22	2MBI450VN-120-80	27	2MBI600XNG170-50	28	2SK3469-01MR	87

Type Number Index

	Page		Page		Page		Page		Page		Page
2SK3474-01	86	2SK3650-01L, S	86	2SK3931-01	87	6MBI100XAE120-50	18	6MBP15XSD060-50	42	7MBP25VDA120-50	45
2SK3501-01	88	2SK3651-01R	86	2SK3932-01MR	87	6MBI100XBA120-50	18	6MBP15XSF060-50	42	7MBP25VFN120-50	43
2SK3502-01MR	88	2SK3676-01L, S	88	2SK3933-01L, S	87	6MBI100XXA120-50	18	6MBP200VDA060-50	45	7MBP300VEA060-50	45
2SK3504-01	87	2SK3680-01	87	2SK3981-01	88	6MBI150U4B-170-50	20	6MBP200VDN060-50	45	7MBP35VDA120-50	45
2SK3505-01MR	87	2SK3681-01	88	2SK3982-01MR	88	6MBI150VB-060-50	18	6MBP200VEA060-50	45	7MBP35VFN120-50	43
2SK3512-01L, S	87	2SK3682-01	87	2SK3983-01L, S	88	6MBI150VB-120-50	19	6MBP200VEA120-50	45	7MBP400VEA060-50	45
2SK3513-01L, S	88	2SK3683-01MR	87	2SK3985-01	87	6MBI150VX-060-50	18	6MBP20VAA060-50	43	7MBP50VDA060-50	45
2SK3514-01	87	2SK3684-01L, S	87	2SK3986-01MR	87	6MBI150VX-060-80	18	6MBP20XSD060-50	42	7MBP50VDA120-50	45
2SK3515-01MR	87	2SK3685-01	87	2SK3987-01L, S	87	6MBI150VX-120-50	19	6MBP20XSF060-50	42	7MBP50VDN120-50	45
2SK3516-01L, S	87	2SK3686-01	88	2SK3988-01	88	6MBI150VX-120-80	19	6MBP25VAA120-50	43	7MBP50VFN060-50	43
2SK3519-01	87	2SK3687-01MR	88	2SK3989-01MR	88	6MBI150XBA120-50	18	6MBP25VBA120-50	43	7MBP50VFN120-50	43
2SK3520-01MR	87	2SK3688-01L, S	88	2SK3990-01L, S	88	6MBI150XXA120-50	18	6MBP25VDA120-50	45	7MBP75VDA060-50	45
2SK3521-01L, S	87	2SK3689-01	88	2SK4004-01MR	87	6MBI180VB-120-50	19	6MBP25VFN120-50	43	7MBP75VDA120-50	45
2SK3522-01	87	2SK3692-01	87	2SK4040-01	87	6MBI180VB-120-55	19	6MBP300VEA060-50	45	7MBP75VDN120-50	45
2SK3523-01R	87	2SK3693-01MR	87	2SK4047-01S	90	6MBI180VX-120-50	19	6MBP30VAA060-50	43	7MBP75VFN060-50	43
2SK3524-01	88	2SK3694-01L, S	87	2SK4047-01S	94	6MBI180VX-120-55	19	6MBP30XSD060-50	42	7MBR100VB060-50	13
2SK3525-01MR	88	2SK3695-01	89	2SK4068-01	90	6MBI180VX-120-80	19	6MBP30XSF060-50	42	7MBR100VN120-50	14
2SK3526-01L, S	88	2SK3696-01MR	89	2SK4068-01	94	6MBI180VX-120-85	19	6MBP35VBA120-50	43	7MBR100VP060-50	13
2SK3527-01	88	2SK3697-01	89	4MBI220VF-170R2-50	40	6MBI200XBA120-50	18	6MBP35VDA120-50	45	7MBR100VR060-50	13
2SK3528-01R	88	2SK3698-01	88	4MBI220VF-170R2-60	40	6MBI200XBE120-50	18	6MBP35VFN120-50	43	7MBR100VR120-50	14
2SK3535-01	86	2SK3699-01MR	88	4MBI300VG-120R-50	40	6MBI200XXA120-50	18	6MBP35XSD060-50	42	7MBR100VX120-50	17
2SK3537-01MR	86	2SK3725-01	87	4MBI300VG-120R1-50	40	6MBI200XXE120-50	18	6MBP35XSF060-50	42	7MBR100VX120-80	17
2SK3554-01	86	2SK3726-01MR	87	4MBI340VF-120R-50	40	6MBI225V-120-50	21	6MBP400VEA060-50	45	7MBR100VY060-50	15
2SK3555-01MR	86	2SK3727-01	88	4MBI400VF-120R-50	40	6MBI300V-120-50	21	6MBP50VAA060-50	43	7MBR100VY060-80	15
2SK3556-01L, S	86	2SK3728-01MR	88	4MBI400VG-060R-50	40	6MBI300V-120-80	21	6MBP50VBA060-50	43	7MBR100VZ060-50	15
2SK3580-01MR	87	2SK3730-01MR	90	4MBI450VB-120R1-50	40	6MBI300V-170-50	21	6MBP50VBA120-50	43	7MBR100VZ060-80	15
2SK3581-01L, S	87	2SK3730-01MR	94	4MBI450VB-120R1-60	40	6MBI450V-120-50	21	6MBP50VDA060-50	45	7MBR100VZ120-50	17
2SK3590-01	86	2SK3753-01R	88	4MBI450VB-170R2-50	40	6MBI450V-170-50	21	6MBP50VDA120-50	45	7MBR100VZ120-80	17
2SK3591-01MR	86	2SK3772-01	87	4MBI450VB-170R2-60	40	6MBI450V-170-80	21	6MBP50VDN120-50	45	7MBR100XNA065-50	13
2SK3592-01L, S	86	2SK3773-01MR	87	4MBI450VF-120RD-50	40	6MBI50VA-060-50	18	6MBP50VFN060-50	43	7MBR100XNA120-50	14
2SK3593-01	86	2SK3774-01L, S	87	4MBI600VB-170R2-50	40	6MBI50VA-120-50	19	6MBP50VFN120-50	43	7MBR100XPE065-50	13
2SK3594-01	86	2SK3775-01	87	4MBI600VB-170R2-60	40	6MBI50VW-060-50	18	6MBP75VBA060-50	43	7MBR100XRA065-50	13
2SK3595-01MR	86	2SK3778-01	86	4MBI600VC-120-50	40	6MBI50VW-120-50	19	6MBP75VDA060-50	45	7MBR100XRA120-50	14
2SK3596-01L, S	86	2SK3779-01R	86	4MBI600VC-120-60	40	6MBI550V-120-50	21	6MBP75VDA120-50	45	7MBR100XRE120-50	14
2SK3597-01	86	2SK3804-01S	90	4MBI650VB-120R1-50	40	6MBI75VA-060-50	18	6MBP75VDN120-50	45	7MBR100XXA065-50	15
2SK3598-01	86	2SK3804-01S	94	4MBI650VB-120R1-60	40	6MBI75VA-120-50	19	6MBP75VFN060-50	43	7MBR100XXA120-50	16
2SK3599-01MR	86	2SK3882-01	86	4MBI900VB-120R1-50	40	6MBI75VW-060-50	18	6MSI100VAB-120-50	51	7MBR100XYE065-50	15
2SK3600-01L, S	86	2SK3886-01MR	86	4MBI900VB-120R1-60	40	6MBI75VW-120-50	19	7MBP100VDA060-50	45	7MBR100XZA065-50	15
2SK3602-01	86	2SK3887-01	88	4MBI900VB-120RA-50	40	6MBI800XV-075V-01	49	7MBP100VDA120-50	45	7MBR100XZA120-50	16
2SK3603-01MR	86	2SK3888-01MR	88	4MBI900VB-120RA-60	40	6MBP100VDA060-50	45	7MBP100VDN060-50	45	7MBR10VKA060-50	11
2SK3604-01L, S	86	2SK3889-01L, S	88	6MBI100U4B-170-50	20	6MBP100VDA120-50	45	7MBP100VDN120-50	45	7MBR10VKA120-50	12
2SK3606-01	86	2SK3891-01R	88	6MBI100VA-060-50	18	6MBP100VDN060-50	45	7MBP100VEA120-50	45	7MBR10VKC060-50	11
2SK3607-01MR	86	2SK3916-01	87	6MBI100VA-120-50	19	6MBP100VDN120-50	45	7MBP100VFN060-50	43	7MBR10VKC120-50	12
2SK3608-01L, S	86	2SK3917-01MR	87	6MBI100VB-120-50	19	6MBP100VEA120-50	45	7MBP150VDA060-50	45	7MBR10XKA065-50	11
2SK3609-01	86	2SK3920-01	86	6MBI100VW-060-50	18	6MBP100VFN060-50	43	7MBP150VDN060-50	45	7MBR10XKA120-50	12
2SK3610-01	86	2SK3921-01L, S	86	6MBI100VW-120-50	19	6MBP10VAA120-50	43	7MBP150VEA120-50	45	7MBR10XKC065-50	11
2SK3611-01MR	86	2SK3922-01	86	6MBI100VX-120-50	19	6MBP150VDA060-50	45	7MBP200VDA060-50	45	7MBR10XKC120-50	12
2SK3612-01L, S	86	2SK3928-01	89	6MBI100VX-120-80	19	6MBP150VDN060-50	45	7MBP200VDN060-50	45	7MBR150VN120-50	14
2SK3648-01	86	2SK3929-01MR	89	6MBI100VX-170-50	20	6MBP150VEA120-50	45	7MBP200VEA060-50	45	7MBR150VR060-50	13
2SK3649-01MR	86	2SK3930-01L, S	89	6MBI100VX-170-80	20	6MBP15VAA120-50	43	7MBP200VEA120-50	45	7MBR150VR120-50	14

Type Number Index

	Page		Page		Page		Page		Page		Page
7MBR150VX120-50	17	7MBR35VKB120-50	12	7MBR75VX120-80	17	F5074H	95	FA5696N	65	FDCP10S65A	56
7MBR150VX120-80	17	7MBR35VKD120-50	12	7MBR75VY060-50	15	F5106H	95	FA5752N	68	FDCP20C65	55
7MBR150VZ060-50	15	7MBR35VM120-50	14	7MBR75VY060-80	15	F5112H	95	FA5760N	67	FDCP20C65A	56
7MBR150VZ060-80	15	7MBR35VP120-50	14	7MBR75VZ120-50	17	FA13842P/N	61	FA6A00N	67	FDCP25S65	55
7MBR150VZ120-50	17	7MBR35VW120-50	17	7MBR75VZ120-80	17	FA13843P/N	61	FA6A10N	67	FDCP25S65A	56
7MBR150VZ120-80	17	7MBR35VW120-80	17	7MBR75XMA065-50	13	FA13844P/N	61	FA6A11N	67	FDCW18T120	55
7MBR150XNA065-50	13	7MBR35VY120-50	17	7MBR75XME120-50	14	FA13845P/N	61	FA6A19N	67	FDCY10S65	55
7MBR150XNE120-50	14	7MBR35VY120-80	17	7MBR75XNA065-50	13	FA1A00N	65	FA6A30N	67	FDCY10S65A	56
7MBR150XRA065-50	13	7MBR35XKB120-50	12	7MBR75XNA120-50	14	FA1A01N	65	FA6A31N	67	FDCY18S120	55
7MBR150XRE065-50	13	7MBR35XKD120-50	12	7MBR75XPA065-50	13	FA1A10N	65	FA6B20N	67	FDCY18S120A	56
7MBR150XRE120-50	14	7MBR35XMA120-50	14	7MBR75XPE120-50	14	FA1A11N	65	FA7700V	69	FDCY20C65	55
7MBR150XXA065-50	15	7MBR35XPA120-50	14	7MBR75XRA120-50	14	FA1A21N	65	FA7701V	69	FDCY20C65A	56
7MBR150XXE120-50	16	7MBR35XWA120-50	16	7MBR75XRE120-50	14	FA1A50N	65	FA7703V	69	FDCY25S65	55
7MBR150XZA065-50	15	7MBR35XYA120-50	16	7MBR75XWA065-50	15	FA1A60N	65	FA7764N/P	69	FDCY25S65A	56
7MBR150XZE120-50	16	7MBR50VA060-50	13	7MBR75XWE120-50	16	FA3641P/N	61	FA8A00N	59	FDCY36C120	55
7MBR15VKA060-50	11	7MBR50VB120-50	14	7MBR75XXA065-50	15	FA3647P/N	61	FA8A01N	59	FDCY36C120A	56
7MBR15VKA120-50	12	7MBR50VKB060-50	11	7MBR75XXA120-50	16	FA3687V	69	FA8A12N	59	FDCY50C65	55
7MBR15VKB120-50	12	7MBR50VKD060-50	11	7MBR75XYA065-50	15	FA5502P/M	65	FA8A27N	59	FDCY50C65A	56
7MBR15VKC060-50	11	7MBR50VM120-50	14	7MBR75XYE120-50	16	FA5504P/N	61	FA8A37N	59	FDRP15S60L	109
7MBR15VKC120-50	12	7MBR50VN120-50	14	7MBR75XZA120-50	16	FA5510P/N	61	FA8A39N	59	FDRP25S60L	109
7MBR15VKD120-50	12	7MBR50VP060-50	13	7MSR100VAB060-50	51	FA5511P/N	61	FA8A40N	59	FDRW12S120J	110
7MBR15XKA065-50	11	7MBR50VP120-50	14	7MSR35VAB120-50	51	FA5514P/N	61	FA8A41N	59	FDRW15S60L	109
7MBR15XKA120-50	12	7MBR50VR120-50	14	7MSR50VAB060-50	51	FA5515P/N	61	FA8A60N	59	FDRW20S120J	110
7MBR15XKB120-50	12	7MBR50VW120-50	17	7MSR50VAB120-50	51	FA5570N	63	FA8A61N	59	FDRW25S60L	109
7MBR15XKC065-50	11	7MBR50VW120-80	17	7MSR75VAB060-50	51	FA5571N	63	FA8A64N	59	FDRW30S120J	110
7MBR15XKC120-50	12	7MBR50VX120-50	17	EPL4PC-R3S	111	FA5572N	63	FA8A65N	59	FDRW35S60L	109
7MBR15XKD120-50	12	7MBR50VX120-80	17	EPL6GC-R3S	111	FA5573N	63	FA8A70N	59	FDRW40C120J	110
7MBR20VKA060-50	11	7MBR50VY060-50	15	ESAD83-004R	108	FA5574N	63	FA8A71N	59	FDRW50C60L	109
7MBR20VKC060-50	11	7MBR50VY060-80	15	ESAD83-006R	108	FA5577N	63	FA8A74N	59	FDRW60C120J	110
7MBR20XKA065-50	11	7MBR50VY120-50	17	ESAD83M-004RR	108	FA5590N	65	FA8A75N	59	FDRW60T65L	109
7MBR20XKC065-50	11	7MBR50VY120-80	17	ESAD83M-006RR	108	FA5591N	65	FA8A80N	59	FDRW70C60L	109
7MBR25VA120-50	14	7MBR50VZ120-50	17	ESAD92-02R	108	FA5601N	65	FA8A81N	59	FDRW75T60L	109
7MBR25VKB120-50	12	7MBR50VZ120-80	17	ESAD92-03R	108	FA5604N	61	FA8A84N	59	FGW15N120H	48
7MBR25VKD120-50	12	7MBR50XKB065-50	11	ESAD92M-02RR	108	FA5605N	61	FA8A85N	59	FGW15N120HD	48
7MBR25VM120-50	14	7MBR50XKD065-50	11	ESAD92M-03RR	108	FA5606N	61	FA8A90N	59	FGW15N120VD	48
7MBR25VP120-50	14	7MBR50XMA065-50	13	ESAE92-03R	108	FA5607N	61	FA8A91N	59	FGW25N120VD	48
7MBR25VW120-50	17	7MBR50XMA120-50	14	ESAF92-03R	108	FA5612N	65	FA8A94N	59	FGW25N120W	47
7MBR25VW120-80	17	7MBR50XPA065-50	13	F5018	95	FA5613N	65	FA8A95N	59	FGW25N120WD	47
7MBR25VY120-50	17	7MBR50XPA120-50	14	F5019	95	FA5614N	65	FA8B16N	59	FGW25N120WE	47
7MBR25VY120-80	17	7MBR50XPE120-50	14	F5020	95	FA5615N	65	FDCA10S65	55	FGW30N120H	48
7MBR25XKA120-50	12	7MBR50XWA065-50	15	F5033	95	FA5640N	63	FDCA18S120	55	FGW30N120HD	48
7MBR25XKB120-50	12	7MBR50XWA120-50	16	F5041	95	FA5641N	63	FDCA20C65	55	FGW30N60VD	48
7MBR25XKC120-50	12	7MBR50XYA065-50	15	F5042	95	FA5642N	63	FDCA25S65	55	FGW30N65W	47
7MBR25XKD120-50	12	7MBR50XYA120-50	16	F5043	95	FA5643N	63	FDCC10S65	55	FGW30XS65	47
7MBR30VKA060-50	11	7MBR75VB060-50	13	F5044H	95	FA5644N	63	FDCC10S65A	56	FGW30XS65C	47
7MBR30VKC060-50	11	7MBR75VB120-50	14	F5045P	95	FA5648N	63	FDCC20C65	55	FGW35N60H	48
7MBR30XKA065-50	11	7MBR75VN120-50	14	F5048	95	FA5650N	68	FDCC20C65A	56	FGW35N60HC	48
7MBR30XKC065-50	11	7MBR75VP060-50	13	F5055	95	FA5651N	68	FDCC25S65	55	FGW35N60HD	48
7MBR35VA120-50	14	7MBR75VR120-50	14	F5062H	95	FA5680N	59	FDCC25S65A	56	FGW40N120H	48
7MBR35VB120-50	14	7MBR75VX120-50	17	F5063L	95	FA5681N	59	FDCP10S65	55	FGW40N120HD	48

Type Number Index

	Page		Page		Page		Page		Page		Page
FGW40N120VD	48	FMC13N60E	81	FMH22N60S1FD	78	FML60N093S2FD	76	FMP60N160S2	74	FMV15N60S1	77
FGW40N120W	47	FMC13N60ES	84	FMH23N50E	80	FML60N103S2	74	FMP60N170S2FD	76	FMV15N70E	81
FGW40N120WD	47	FMC16N50E	80	FMH23N50ES	83	FML60N104S2FD	76	FMP60N190S2	74	FMV16N50E	80
FGW40N120WE	47	FMC16N50ES	83	FMH23N60E	81	FML60N115S2	74	FMP60N280S2	74	FMV16N50ES	83
FGW40N65W	47	FMC16N60E	81	FMH23N60ES	84	FML60N118S2FD	76	FMP60N380S2	74	FMV16N60E	81
FGW40N65WD	47	FMC16N60ES	84	FMH28N50E	80	FML60N146S2	74	FMP65N15T2	90	FMV16N60ES	84
FGW40N65WE	47	FMC20N50E	80	FMH28N50ES	83	FML60N150S2FD	76	FMP80N10T2	90	FMV17N60ES	84
FGW40XS65	47	FMC20N50ES	83	FMH30N60S1	77	FML60N187S2	74	FMR09N90E	82	FMV19N60E	81
FGW40XS65C	47	FMC29N60S1FDA	91	FMH30N60S1FD	78	FML60N191S2FD	76	FMR11N90E	82	FMV19N60ES	84
FGW50N60H	48	FMC40N060S2FDA	93	FMH35N60S1	77	FML60N223S2	74	FMR17N60ES	84	FMV20N50E	80
FGW50N60HC	48	FMC49N20T2	90	FMH35N60S1FD	78	FMP03N60E	81	FMR19N60E	81	FMV20N50ES	83
FGW50N60HD	48	FMC50N071S2FDA	93	FMH40N60S1	77	FMP05N50E	80	FMR19N60ES	84	FMV20N60S1	77
FGW50N60VD	48	FMC60N079S2A	92	FMH40N60S1FD	78	FMP05N60E	81	FMR21N50ES	83	FMV20N60S1FD	78
FGW50N65W	47	FMC60N081S2FDA	93	FMH47N60S1	77	FMP06N60E	81	FMR23N50E	80	FMV21N50ES	83
FGW50N65WD	47	FMC60N088S2A	92	FMH47N60S1FD	78	FMP06N60ES	84	FMR23N50ES	83	FMV22N60S1	77
FGW50N65WE	47	FMC60N099S2A	92	FMH60N190S2	74	FMP07N50E	80	FMR23N60E	81	FMV22N60S1FD	78
FGW50XS65	47	FMC60N105S2FDA	93	FMH60N280S2	74	FMP07N60S1	77	FMR23N60ES	84	FMV23N50E	80
FGW50XS65C	47	FMC60N125S2A	92	FMI03N60E	81	FMP08N50E	80	FMR28N50E	80	FMV23N50ES	83
FGW60N65W	47	FMC60N133S2FDA	93	FMI05N50E	80	FMP08N60S1	77	FMR28N50ES	83	FMV24N25G	86
FGW60N65WD	47	FMC60N160S2A	92	FMI05N60E	81	FMP10N60E	81	FMV03N60E	81	FMV30N60S1	77
FGW60N65WE	47	FMC65N15T2	90	FMI06N60ES	84	FMP10N60S1	77	FMV05N50E	80	FMV30N60S1FD	78
FGW75N60H	48	FMC80N10R6	90	FMI06N80E	81	FMP11N60E	81	FMV05N60E	81	FMV35N60S1	77
FGW75N60HC	48	FMC80N10R6	94	FMI06N90E	82	FMP12N50E	80	FMV06N60E	81	FMV35N60S1FD	78
FGW75N60HD	48	FMC80N10T2	90	FMI07N50E	80	FMP12N50ES	83	FMV06N60ES	84	FMV40N60S1	77
FGW75N65W	47	FMH06N80E	81	FMI07N90E	82	FMP12N60ES	84	FMV06N80E	81	FMV60N070S2	75
FGW75N65WE	47	FMH06N90E	82	FMI08N80E	81	FMP13N60E	81	FMV06N90E	82	FMV60N075S2FD	76
FGW75XS65	47	FMH07N70E	81	FMI10N60E	81	FMP13N60ES	84	FMV07N50E	80	FMV60N079S2	75
FGW75XS65C	47	FMH07N90E	82	FMI11N60E	81	FMP13N60S1	77	FMV07N60S1	77	FMV60N084S2FD	76
FGW85N60RB	48	FMH08N80E	81	FMI12N50E	80	FMP15N60S1	77	FMV07N65E	81	FMV60N088S2	75
FGZ40N120WE	47	FMH09N70E	81	FMI12N50ES	83	FMP16N50E	80	FMV07N70E	81	FMV60N094S2FD	76
FGZ50N65WD	47	FMH09N90E	82	FMI12N60ES	84	FMP16N50ES	83	FMV07N90E	82	FMV60N099S2	74
FGZ50N65WE	47	FMH10N80E	81	FMI13N60E	81	FMP16N60E	81	FMV08N50E	80	FMV60N105S2FD	76
FGZ75N65WE	47	FMH11N70E	81	FMI13N60ES	84	FMP16N60ES	84	FMV08N60S1	77	FMV60N125S2	74
FMA49N20T2	90	FMH11N90E	82	FMI16N50E	80	FMP20N50E	80	FMV08N80E	81	FMV60N133S2FD	76
FMA65N15T2	90	FMH13N60ES	84	FMI16N50ES	83	FMP20N50ES	83	FMV09N65E	81	FMV60N160S2	74
FMA80N10T2	90	FMH13N60S1	77	FMI16N60E	81	FMP20N60S1	77	FMV09N70E	81	FMV60N170S2FD	76
FMC03N60E	81	FMH13N80E	81	FMI16N60ES	84	FMP20N60S1FD	78	FMV09N90E	82	FMV60N190S2	74
FMC05N50E	80	FMH15N60S1	77	FMI20N50E	80	FMP22N60S1	77	FMV10N60E	81	FMV60N280S2	74
FMC05N60E	81	FMH16N50E	80	FMI20N50ES	83	FMP22N60S1FD	78	FMV10N60S1	77	FMV60N380S2	74
FMC06N60ES	84	FMH16N50ES	83	FMI49N20T2	90	FMP30N60S1	77	FMV10N80E	81	FMW15N60S1	77
FMC06N80E	81	FMH16N60ES	84	FMI65N15T2	90	FMP30N60S1FD	78	FMV11N60E	81	FMW20N60S1	77
FMC06N90E	82	FMH17N60ES	84	FMI80N10T2	90	FMP49N20T2	90	FMV11N70E	81	FMW20N60S1FD	78
FMC07N50E	80	FMH19N60E	81	FML12N50ES	83	FMP60N079S2	75	FMV11N90E	82	FMW22N60S1	77
FMC07N90E	82	FMH19N60ES	84	FML12N60ES	84	FMP60N084S2FD	76	FMV12N50E	80	FMW22N60S1FD	78
FMC08N80E	81	FMH20N50E	80	FML13N60ES	84	FMP60N088S2	75	FMV12N50ES	83	FMW30N60S1	77
FMC10N60E	81	FMH20N50ES	83	FML16N50ES	83	FMP60N094S2FD	76	FMV12N60ES	84	FMW30N60S1FD	78
FMC11N60E	81	FMH20N60S1	77	FML16N60ES	84	FMP60N099S2	74	FMV13N60E	81	FMW35N60S1	77
FMC12N50E	80	FMH20N60S1FD	78	FML19N50G	87	FMP60N105S2FD	76	FMV13N60ES	84	FMW35N60S1FD	78
FMC12N50ES	83	FMH21N50ES	83	FML20N50ES	83	FMP60N125S2	74	FMV13N60S1	77	FMW40N60S1	77
FMC12N60ES	84	FMH22N60S1	77	FML60N091S2	74	FMP60N133S2FD	76	FMV13N80E	81	FMW40N60S1FD	78

Type Number Index

	Page		Page		Page		Page		Page		Page
FMW47N60S1	77	FMY60N105S2FDA	93	TP862C15R	103	YA865C15R	103	YG838C04R	99	YG982C3R	107
FMW47N60S1FD	78	FMY60N125S2A	92	TP865C12R	103	YA868C04R	102	YG861S12R	101	YG982C4R	107
FMW57N60S1	77	FMY60N133S2FDA	93	TP865C15R	103	YA868C06R	102	YG861S15R	101	YG982C6R	105
FMW57N60S1FD	78	FMY60N160S2A	92	TP868C10R	103	YA868C08R	102	YG862C06R	102	YG982S6R	105
FMW60N025S2	75	FMY67N30ESF	94	TP869C06R	102	YA868C10R	103	YG862C08R	102	YG985C3R	107
FMW60N027S2FD	76	FMY67N60S1FDA	91	TP869C08R	102	YA868C12R	103	YG862C10R	103	YG985C4R	107
FMW60N040S2	75	FMY68N60S1A	91	TP869C10R	103	YA868C15R	103	YG862C12R	103	YG985C6R	105
FMW60N043S2FD	76	FMY72N30ES	94	TP901C2R	108	YA869C06R	102	YG862C15R	103		
FMW60N055S2	75	KP883C02	99	TP902C2R	108	YA869C08R	102	YG865C04R	102		
FMW60N059S2FD	76	KP923C2	106	TP902C3R	108	YA869C10R	103	YG865C06R	102		
FMW60N070S2	75	KP926S2	106	TP906C2R	108	YA869C12R	103	YG865C08R	102		
FMW60N075S2FD	76	KS823C03	99	TS802C04R	108	YA869C15R	103	YG865C10R	103		
FMW60N079S2	75	KS823C04	99	TS805C04R	108	YA872C10R	100	YG865C12R	103		
FMW60N084S2FD	76	KS823C09	99	TS808C06R	108	YA872C12R	100	YG865C15R	103		
FMW60N088S2	75	KS826S04	98	TS862C06R	102	YA872C15R	100	YG868C04R	102		
FMW60N094S2FD	76	KS883C02	99	TS862C08R	102	YA872C20R	100	YG868C06R	102		
FMW60N099S2	74	KS923C2	106	TS862C10R	103	YA875C10R	100	YG868C08R	102		
FMW60N105S2FD	76	KS926S2	106	TS862C12R	103	YA875C12R	100	YG868C10R	103		
FMW60N125S2	74	KS986S3	107	TS862C15R	103	YA875C15R	100	YG868C12R	103		
FMW60N133S2FD	76	KS986S4	107	TS865C04R	102	YA875C20R	100	YG868C15R	103		
FMW60N160S2	74	MS808C06	99	TS865C06R	102	YA878C10R	100	YG869C06R	102		
FMW60N170S2FD	76	MS838C04	99	TS865C08R	102	YA878C12R	100	YG869C08R	102		
FMW60N190S2	74	MS862C08	102	TS865C10R	103	YA878C15R	100	YG869C10R	103		
FMW79N60S1	77	MS865C04	102	TS865C12R	103	YA878C20R	100	YG869C12R	103		
FMW79N60S1FD	78	MS865C08	102	TS865C15R	103	YA971S6R	104	YG869C15R	103		
FMY100N06T	94	MS865C10	103	TS868C04R	102	YA972S6R	104	YG872C10R	100		
FMY100N10R6	90	MS865C12	103	TS868C06R	102	YA975C6R	104	YG872C12R	100		
FMY100N10R6	94	MS865C15	103	TS868C08R	102	YA981S6R	105	YG872C15R	100		
FMY22N60ESF	94	MS868C04	102	TS868C10R	103	YA982C3R	107	YG872C20R	100		
FMY24N60ES	94	MS868C10	103	TS868C12R	103	YA982C4R	107	YG875C10R	100		
FMY29N60S1FDA	91	MS868C12	103	TS868C15R	103	YA982C6R	105	YG875C12R	100		
FMY30N60ESF	94	MS868C15	103	TS902C2R	108	YA982S6R	105	YG875C15R	100		
FMY31N60ES	94	MS906C2	106	TS902C3R	108	YA985C3R	107	YG875C20R	100		
FMY35N60ESF	94	MS906C3	106	TS906C2R	108	YA985C4R	107	YG878C10R	100		
FMY36N60ES	94	MS985C3	107	TS982C3R	107	YA985C6R	105	YG878C12R	100		
FMY46N60S1FDA	91	MS985C4	107	TS982C4R	107	YG801C04R	99	YG878C15R	100		
FMY47N30ESF	94	PA868C10R	103	TS982C6R	105	YG801C06R	99	YG878C20R	100		
FMY47N60S1A	91	PA868C15R	103	TS985C3R	107	YG801C10R	99	YG901C2R	106		
FMY50N071S2FDA	93	PA905C4R	108	TS985C4R	107	YG802C04R	99	YG901C3R	106		
FMY50N30ES	94	PG865C15R	103	TS985C6R	105	YG802C06R	99	YG902C2R	106		
FMY52N60S1FDA	91	PG985C3R	107	YA862C06R	102	YG802C10R	99	YG902C3R	106		
FMY52N65S1FDA	91	PG985C4R	107	YA862C08R	102	YG803C06R	99	YG906C2R	106		
FMY53N60S1A	91	PH865C12	103	YA862C10R	103	YG804S06R	98	YG911S2R	106		
FMY60N025S2A	92	PH865C15	103	YA862C12R	103	YG805C04R	99	YG911S3R	106		
FMY60N040S2A	92	PH868C12	103	YA862C15R	103	YG805C06R	99	YG912S2R	106		
FMY60N070S2A	92	PH868C15	103	YA865C04R	102	YG805C10R	99	YG971S6R	104		
FMY60N079S2A	92	PH975C6	104	YA865C06R	102	YG808C10R	99	YG971S8R	104		
FMY60N081S2FDA	93	PH985C6	105	YA865C08R	102	YG811S04R	98	YG972S6R	104		
FMY60N088S2A	92	TP802C04R	108	YA865C10R	103	YG811S06R	98	YG975C6R	104		
FMY60N099S2A	92	TP862C12R	103	YA865C12R	103	YG812S04R	98	YG981S6R	105		

Maintenance products

- Models listed below are for maintenance products only.
- Do not use them for new designing

Products	Type number	Products	Type number	Products	Type number
Power Devices	1MBI1200U4C-120	Power Devices	2MBI300UC-170	Power Devices	6MBP25RU2A120
	1MBI1200U4C-170		2MBI300UD-120		6MBP25TEA120-50
	1MBI1600U4C-120		2MBI300UD-120-50		6MBP300RA060
	1MBI1600U4C-170		2MBI300UE-120		6MBP30RTB060
	1MBI2400U4D-120		2MBI400U2B-060-50		6MBP30RTB060-50
	1MBI2400U4D-170		2MBI400U4H-120		6MBP35RJB120-50
	1MBI300U4-120		2MBI400U4H-120-50		6MBP50RA060
	1MBI3600U4D-120		2MBI400U4H-170		6MBP50RA120
	1MBI3600U4D-170		2MBI400U4H-170-50		6MBP50RJ120
	1MBI400U4-120		2MBI450U4E-120		6MBP50RTB060
	1MBI600U4-120		2MBI450U4J-120-50		6MBP50RTB060-50
	1MBI600U4B-120		2MBI450U4N-120-50		6MBP50RTJ060
	1MBI800U4B-120		2MBI450U4N-170-50		6MBP50RU2A120
	2MBI100TA-060-50		2MBI450UE-120		6MBP50TBA060-50
	2MBI100U4A-120		2MBI600U4G-120		6MBP50TEA060
	2MBI100U4A-120-50		2MBI600U4G-170		6MBP50TEA060-50
	2MBI100U4H-170-50		2MBI75U4A-120		6MBP50TEA120-50
	2MBI1200U4G-120		2MBI75U4A-120-50		6MBP75RA060
	2MBI1200U4G-170		2MBI75UA-120		6MBP75RA120
	2MBI150TA-060-50		2MBI75UA-120-50		6MBP75RJ120
	2MBI150U2A-060-50		2MBI800U4G-120		6MBP75RTB060
	2MBI150U4A-120		2MBI800U4G-170		6MBP75RTB060-50
	2MBI150U4A-120-50		4MBI100T-060		6MBP75RTJ060
	2MBI150U4B-120		6MBI35U4A-120-50		6MBP75RU2A120
	2MBI150U4B-120-50		6MBI50U4A-120-50		6MBP75RU2A120-50
	2MBI150U4H-120		6MBI50UA-120-50		6MBP75TBA060-50
	2MBI150U4H-120-50		6MBI75U4A-120-50		6MBP75TEA060-50
	2MBI150U4H-170		6MBI75U4B-120-50		6MBP75TEA120-50
	2MBI150U4H-170-50		6MBI75UA-120-50		7MBP25RA120
	2MBI150UA-120		6MBI100U4B-120-50		7MBP25RU2A120-50
	2MBI150UA-120-50		6MBI100UB-120-50		7MBP50RE120
	2MBI150UB-120-50		6MBI150U4B-120-50		7MBP50RTA060-50
	2MBI200U2A-060-50		6MBI150UB-120-50		7MBP50RTB060-50
	2MBI200U4B-120		6MBI225U4-120		7MBP50RU2A120-50
	2MBI200U4B-120-50		6MBI225U4-120-50		7MBP75RE120
	2MBI200U4D-120		6MBI300U4-120		7MBP75RTB060-50
	2MBI200U4D-120-50		6MBI300U4-120-50		7MBP75RU2A120
	2MBI200U4H-120		6MBI300U4-170		7MBP75RU2A120-50
	2MBI200U4H-120-50		6MBI450U-120		7MBP75TEA060-50
	2MBI200U4H-170		6MBI450U-170		7MBP75TEA120-50
	2MBI200U4H-170-50		6MBI450U4-120		7MBP80RTA060-50
	2MBI200UB-120		6MBI450U4-120-50		7MBP100RA060
	2MBI200UB-120-50		6MBI450U4-170		7MBP100RA120
	2MBI200UC-120-50		6MBP100RA060		7MBP100RTA060-50
	2MBI200UD-120-50		6MBP100RA120		7MBP100RTB060
	2MBI200UM-120		6MBP100RTB060		7MBP100RTB060-50
	2MBI225U4J-120-50		6MBP100RTB060-50		7MBP100RTJ060
	2MBI225U4N-120-50		6MBP100RTD060-50		7MBP100TEA060-50
	2MBI225U4N-170-50		6MBP100RTJ060		7MBP150RA060
	2MBI300U2B-060-50		6MBP100TEA060		7MBP150RA120
	2MBI300U4D-120		6MBP100TEA060-50		7MBP150RTB060
	2MBI300U4D-120-50		6MBP150RA060		7MBP150RTB060-50
	2MBI300U4E-120		6MBP150RA120		7MBP150RTJ060
	2MBI300U4H-120		6MBP150RTB060		7MBP150TEA060-50
	2MBI300U4H-120-50		6MBP150RTB060-50		7MBP160RTA060-50
	2MBI300U4H-170		6MBP150RTJ060		7MBP200RA060
	2MBI300U4H-170-50		6MBP150TEA060-50		7MBP200RUC060
	2MBI300U4J-120-50		6MBP15RA120		7MBP200RUC060-50
	2MBI300U4N-120-50		6MBP200RA060		7MBR10UF120
	2MBI300U4N-170-50		6MBP20RTA060		7MBR15UF060
	2MBI300UC-120		6MBP25RA120		7MBR15UF120
	2MBI300UC-120-50		6MBP25RJ120		7MBR20UF060

Maintenance products

Products	Type number	Products	Type number
Power Devices	7MBR25U4P120-50	Rectifier Diodes	CB803-03
	7MBR25UA120-50		CB863-06
	7MBR30UF060		CB863-12
	7MBR35U4A120-50		CB863-15
	7MBR35U4P120-50		CB903-4
	7MBR35UA120-50		ERA81-004
	7MBR35UB120-50		ERA82-004
	7MBR50U4P120-50		ERA83-004
	7MBR50UA120-50		ERA83-006
	7MBR50UB120-50		ERA84-009
	7MBR75U4B120-50		ERA85-009
	7MBR75U4R120-50		ERA91-02
	7MBR75UB120-50		ERA92-02
	7MBR100U4B120-50		ERB81-004
	7MBR100UB120-50		ERB83-004
			ERB83-006
			ERB84-009
			ERB91-02
			ERB93-02
			ERC81-004
			ERC81-006
			ERC81S-004
			ERC84-009
			ERC91-02
			FD867-12
			FD867-15
			FD868-12
			FD868-15
			SC802-04
			SC802-06
			SC802-09
			SC902-2
			SD832-03
			SD832-04
			SD833-03
			SD833-04
			SD833-06
			SD833-09
			SD834-03
			SD834-04
			SD862-04
			SD863-04
			SD863-06
			SD863-10
			SD882-02
			SD883-02
			SD883-04

Discontinued products

- Models listed below are discontinued products.
- Do not use them for new designing

Products	Type number	Products	Type number	Products	Type number	
Power Devices	1MBI150NH-060	Power Devices	6MBI35S-140	IPS (Intelligent Power switch)	F5016H	
	1MBI150NK-060		6MBI50S-060		F5017H	
	1MBI200N-120		6MBI50S-120		F5021H	
	1MBI200NH-060		6MBI50S-140		F5022	
	1MBI200NK-060		6MBI75S-060		F5038H	
	1MBI300N-120		6MBI75S-120			
	1MBI300NN-120		6MBI75S-140		Rectifier Diodes	FDLA20C20
	1MBI300NP-120		6MBP15RH060-50			FDLC20C20
	1MBI400N-120		6MBP20RH060-50			FDLH20C20
	1MBI400NN-120		6MBP30RH060-50			FDLP20C20
	1MBI400NP-120		7MBR100SB060			FDLR20C20
	1MBI600NN-060		7MBR100SD060			KP823C03
	1MBI600NP-060		7MBR10SA120	KP823C04		
	2MBI100N-060		7MBR10SA140	KP823C09		
	2MBI100N-120		7MBR10SC120	PA955C6R		
	2MBI100NB-120		7MBR15SA120	PG985C6R		
	2MBI100NC-120		7MBR15SA140	TP858C12R		
	2MBI150N-060		7MBR15SC120	TP869C04R		
	2MBI150N-120		7MBR20SC060	TS862C04R		
	2MBI150NB-120		7MBR25SA120	TS906C3R		
	2MBI150NC-060		7MBR25SA140	TS952C6R		
	2MBI150NC-120		7MBR25SC120	TS955C6R		
	2MBI200N-060		7MBR30SA060	YA852C12R		
	2MBI200N-060-03		7MBR30SC060	YA852C15R		
	2MBI200N-120		7MBR35SB120	YA855C12R		
	2MBI200NB-120		7MBR35SB140	YA855C15R		
	2MBI200NB-120-01		7MBR35SD120	YA858C12R		
	2MBI300N-060		7MBR50SA060	YA858C15R		
	2MBI300N-060-04		7MBR50SB060	YA862C04R		
	2MBI300N-120		7MBR50SB120	YA869C04R		
	2MBI300N-120-01		7MBR50SB140	YA951S6R		
	2MBI300NB-060		7MBR50SC060	YA952C6R		
	2MBI300NB-060-01		7MBR50SD120	YA952S6R		
	2MBI400N-060		7MBR75SB060	YA955C6R		
	2MBI400N-060-01		7MBR75SD060	YG801C09R		
	2MBI50N-060			YG802C03R		
	2MBI50N-120			YG802C09R		
	2MBI600NT-060			YG803C04R		
	2MBI75N-060			YG811S09R		
	2MBI75N-120			YG831C03R		
	4MBI75T-060			YG831C04R		
	4MBI100T-060			YG832C03R		
	4MBI150T-060			YG832C04R		
	4MBI200T-060			YG835C03R		
	1MBI600PX-120			YG835C04R		
	1MBI600PX-140			YG838C03R		
	2MBI100PC-140			YG852C12R		
	2MBI100SC-120			YG852C15R		
	2MBI150PC-140			YG855C12R		
	2MBI150SC-120			YG855C15R		
	2MBI200PB-140			YG858C12R		
	2MBI200S-120			YG858C15R		
	2MBI300P-140			YG862C04R		
	2MBI300S-120			YG864S06R		
	2MBI50P-140			YG869C04R		
	2MBI75P-140			YG881C02R		
	6MBI100S-060			YG882C02R		
	6MBI100S-120			YG885C02R		
	6MBI100S-140			YG906C3R		
6MBI10S-120		YG951S6R				
6MBI15S-120		YG952C6R				
6MBI25S-120		YG952S6R				
6MBI35S-120		YG955C6R				
		Integrated Circuits	FA3635S-H1			
			FA3675F-H1			
			FA3702AV-H1			
			FA5316P			
			FA5317S			
			FA5701P-A2			
			FA5705AP-A2			
			FA5707AP-A2			
			FA5708AP-A2			
			FA7709R-H1			
			FA7716R-H4			
			FA7723R-H4			
			FA7724R-H4			
			FA7724AR-H4			
			FA7728F-D1			
			FA7729R-H1			
			FA7730F-D1			
			FA7731F-D1			
			FA7743N-D1			
		Hybrid ICs for IGBT Drive	EXB840			
			EXB841			

Discontinued products

Products	Type number	Products	Type number
Power MOSFET	2SJ314-01L, S	Power MOSFET	2SK3679-01MR
	2SJ472-01L, S		2SK3690-01
	2SJ473-01L, S		2SK3691-01MR
	2SJ474-01L, S		2SK3769-01MR
	2SJ475-01		2SK3770-01MR
	2SJ476-01L, S		2SK3771-01MR
	2SJ477-01MR		2SK3776-01
	2SK2687-01		2SK3777-01R
	2SK2688-01L, S		2SK3780-01
	2SK2689-01MR		2SK3781-01R
	2SK2690-01		2SK3788-01
	2SK2691-01R		2SK3789-01R
	2SK2806-01		2SK3870-01
	2SK2807-01L, S		2SK3871-01MR
	2SK2808-01MR		2SK3872-01L, S
	2SK2809-01MR		2SK3873-01
	2SK2890-01MR		2SK3874-01R
	2SK2891-01		2SK3875-01
	2SK2892-01R		2SK3876-01R
	2SK2893-01		2SK3883-01
	2SK2894-01R		2SK3884-01
	2SK2895-01		2SK3885-01
	2SK2896-01L, S		2SK3913-01MR
	2SK2897-01MR		2SK3914-01
	2SK2898-01		2SK3915-01MR
	2SK2899-01R		2SK3923-01
	2SK2900-01		2SK3924-01L, S
	2SK2901-01L, S		2SK3925-01
	2SK2902-01MR		2SK3926-01MR
	2SK2903-01MR		2SK3927-01L, S
	2SK2904-01		2SK4005-01MR
	2SK2905-01R		2SK4006-01L, S
	2SK2906-01		FMA18N25G
	2SK2907-01R		
	2SK3362-01		
	2SK3363-01		
	2SK3364-01		
	2SK3517-01		
	2SK3518-01MR		
	2SK3529-01		
	2SK3530-01MR		
	2SK3531-01		
	2SK3532-01MR		
	2SK3533-01		
	2SK3534-01MR		
	2SK3549-01		
	2SK3550-01R		
	2SK3586-01		
	2SK3587-01MR		
	2SK3588-01L, S		
	2SK3589-01		
	2SK3601-01		
	2SK3605-01		
	2SK3613-01		
	2SK3644-01		
	2SK3645-01MR		
	2SK3646-01L, S		
	2SK3647-01		
	2SK3673-01MR		
	2SK3674-01L, S		
	2SK3675-01		
	2SK3677-01MR		
	2SK3678-01		

Global semiconductor website

We will continue to keep our global semiconductor website updated and fulfilled with new information on our semiconductor products including new products release, search function, data sheets, and the related exhibition for our customers all over the world. We hope it will be of much use to our customers. Thank you.

Japanese: www.fujielectric.co.jp/products/semiconductor/

English: www.fujielectric.com/products/semiconductor/

Chinese: www.fujielectric.com/products/semiconductor/cn/

We would like to thank you for your continued patronage and further support for our semiconductor products.

WARNING

1. This Catalog contains the product specifications, characteristics, data, materials, and structures as of March 2018. The contents are subject to change without notice for specification changes or other reasons. When using a product listed in this Catalog, be sure to obtain the latest specifications.
2. All applications described in this Catalog exemplify the use of Fuji's products for your reference only. No right or license, either express or implied, under any patent, copyright, trade secret or other intellectual property right owned by Fuji Electric Co., Ltd. is (or shall be deemed) granted. Fuji Electric Co., Ltd. makes no representation or warranty, whether express or implied, relating to the infringement or alleged infringement of other's intellectual property rights which may arise from the use of the applications described herein.
3. Although Fuji Electric Co., Ltd. is enhancing product quality and reliability, a small percentage of semiconductor products may become faulty. When using Fuji Electric semiconductor products in your equipment, you are requested to take adequate safety measures to prevent the equipment from causing a physical injury, fire, or other problem if any of the products become faulty. It is recommended to make your design fail-safe, flame retardant, and free of malfunction.
4. The products introduced in this Catalog are intended for use in the following electronic and electrical equipment which has normal reliability requirements.
 - Computers
 - OA equipment
 - Communications equipment (terminal devices)
 - Measurement equipment
 - Machine tools
 - Audiovisual equipment
 - Electrical home appliances
 - Personal equipment
 - Industrial robots etc.
5. If you need to use a product in this Catalog for equipment requiring higher reliability than normal, such as for the equipment listed below, it is imperative to contact Fuji Electric Co., Ltd. to obtain prior approval. When using these products for such equipment, take adequate measures such as a backup system to prevent the equipment from malfunctioning even if a Fuji's product incorporated in the equipment becomes faulty.
 - Transportation equipment (mounted on cars and ships)
 - Trunk communications equipment
 - Traffic-signal control equipment
 - Gas leakage detectors with an auto-shut-off feature
 - Emergency equipment for responding to disasters and anti-burglary devices
 - Safety devices
 - Medical equipment
6. Do not use products in this Catalog for the equipment requiring strict reliability such as the following and equivalents to strategic equipment (without limitation).
 - Space equipment
 - Aeronautic equipment
 - Nuclear control equipment
 - Submarine repeater equipment
7. Copyright ©1996-2018 by Fuji Electric Co., Ltd. All rights reserved.
No part of this Catalog may be reproduced in any form or by any means without the express permission of Fuji Electric Co., Ltd.
8. If you have any question about any portion in this Catalog, ask Fuji Electric Co., Ltd. or its sales agents before using the product. Neither Fuji Electric Co., Ltd. nor its agents shall be liable for any injury caused by any use of the products not in accordance with instructions set forth herein.

 **Fuji Electric Co., Ltd.**

Power Semiconductors Group

URL www.fujielectric.com/products/semiconductor/

Head Office:

Gate City Ohsaki, East Tower, 11-2 Osaki 1-chome,
Shinagawa-ku, Tokyo 141-0032, Japan

Fuji Electric Hong Kong Co., Ltd.

Suites 1911-13, 19/F., Tower 6, The Gateway, Harbour City,
Tsim Sha Tsui, Kowloon, Hong Kong
Tel: +852-2664-8699

Fuji Electric Taiwan Co., Ltd.

10F. No.168, Song Jiang Road, Taipei, Taiwan
Tel: +886-2-2515-1850

Fuji Electric Asia Pacific Pte. Ltd.

151 Lorong Chuan, #03-01/01A New Tech Park, SINGAPORE 556741
Tel: +65-6533-0014

Fuji Electric India Private Ltd.

409-410, Meadows, Sahar Plaza, J.B. Nagar Andheri-Kurla Road,
Andheri (E), Mumbai, India 400059
Tel: +91-22-4010-4870

Fuji Electric (China) Co., Ltd.

26F, Global Harbor Tower B,
1188 North KaiXuan Road, PuTuo District,
Shanghai 200062, P.R.China
Tel: +86-21-5496-1177

Fuji Electric Corp. of America

50 Northfield Avenue
Edison, NJ 08837, USA
Tel: +1-732-560-9410

Fuji Electric Europe GmbH

Goethering 58, 63067 Offenbach, am Main, F.R. GERMANY
Tel: +49-69-6690290



Power Semiconductors

IGBT Modules, MOSFETs, All SiC Modules, SiC-Schottky Diodes and Discrete IGBTs

Pre-applied Thermal Interface Material (TIM) **1**



IGBT Modules for 3-Level inverters **4-5**



Hybrid IGBT-Modules with SiC Schottky Barrier Diodes **6-7**



PIM Power Integrated Modules Solder pins & PressFit contacts **8-11**



6-Pack IGBT-Modules, Solder pins & PressFit contacts **12**



2-Pack IGBT-Modules, Spring-, Pin- & PressFit contacts **13**



Standard 1- & 2-Pack IGBT Modules **14**



High Power Modules 1200V, 1700V & 3300V **15**



HPnC High Power next Core **16**



High Power Modules 2-Pack & Chopper **17**



IPM Intelligent Power Modules **18-20**

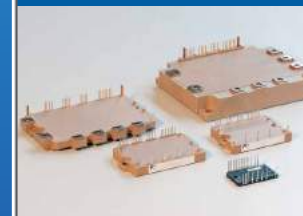

Chopper Modules & High Speed IGBTs **21**



Discrete IGBTs, standard and Reverse Blocking IGBT **22**



Super Junction- MOSFETs with & without FRED **23**



SiC Schottky Barrier Diodes **24**



Fuji Electric Corp. of America
50 Northfield Avenue
Edison, NJ 08837 USA

Tel: (732)560-9410
Fax: (732)457-0042

x-fea-semi-group@fujielectric.com
www.americas.fujielectric.com

Email



Website



Industrialized Process for Pre-applied Thermal Interface Material (TIM)

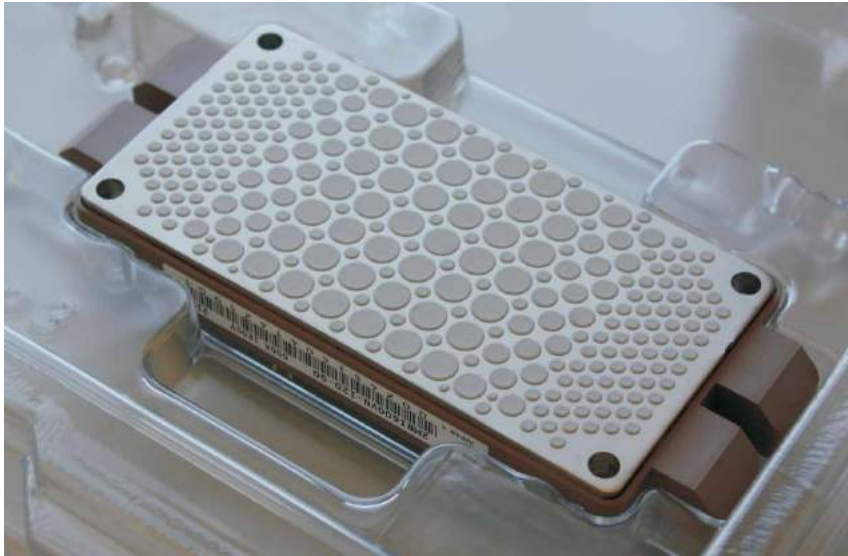

Fuji Electric's printing process of pre-applied TIM is automated and carried out by a computer controlled printing line under clean environment.

Precise printing equipment and optimized module specific printing patterns guaranty a uniform print and maximum thermal conductivity.

3D-imaging tests ensure the compliance of our specified TIM thickness.

The whole process is controlled by our qualified staff to ensure our high quality standards.

Features

- + Optimized for Fuji Electric modules
- + Increase lifetime of IGBT
- + Advanced IGBT power density

Process - Benefits

- + Outsourcing of a dirty process
- + Stable quality level
- + Increased system reliability

Thermal - Benefits

- + Higher thermal conductivity
- + Uniform thermal resistance
- + Higher reliability and life time.

Our range of modules with pre-applied TIM is being continually expanded

For latest availability status please contact us

About Type Name

The Type Name is not exactly the item code for the ordering process

1. Modules with Standard IGBT-Chips

2 M Bi 450 V H - 120 - 50

Suffix - 50 = RoHS compliant

Voltage class: $060 = 600V$ · $065 = 650V$ · $120 = 1200V$ · $170 = 1700V$ · $330 = 3300V$

Package Style

IGBT-series (here V-Series) / IGBT-technology

Current class I_c [A]

Device type & configuration

MBi : Standard IGBT module (1-, 2- and 6-pack)

MBR : PIM IGBT (Power Integrated Module)

MBP : IPM IGBT (Intelligent Power Module)

MSi, MSR: The "S" indicates hybrid module with Si-IGBT & SiC Schottky free wheeling diodes

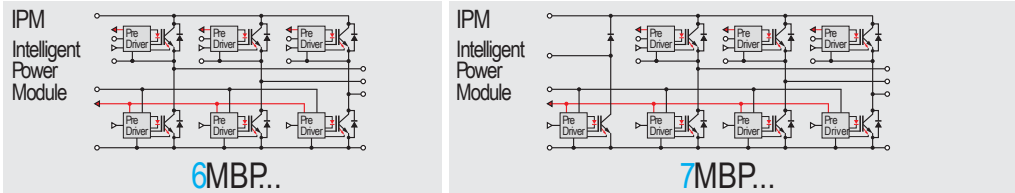
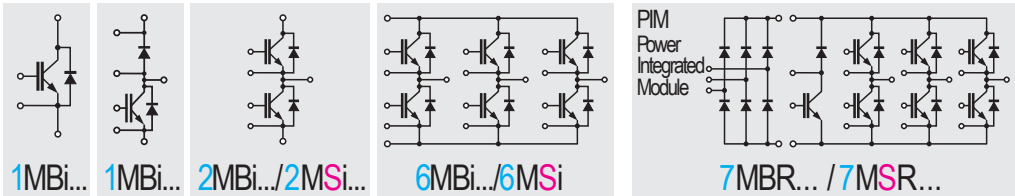

Number of IGBT-switches (not chips)

IGBT development

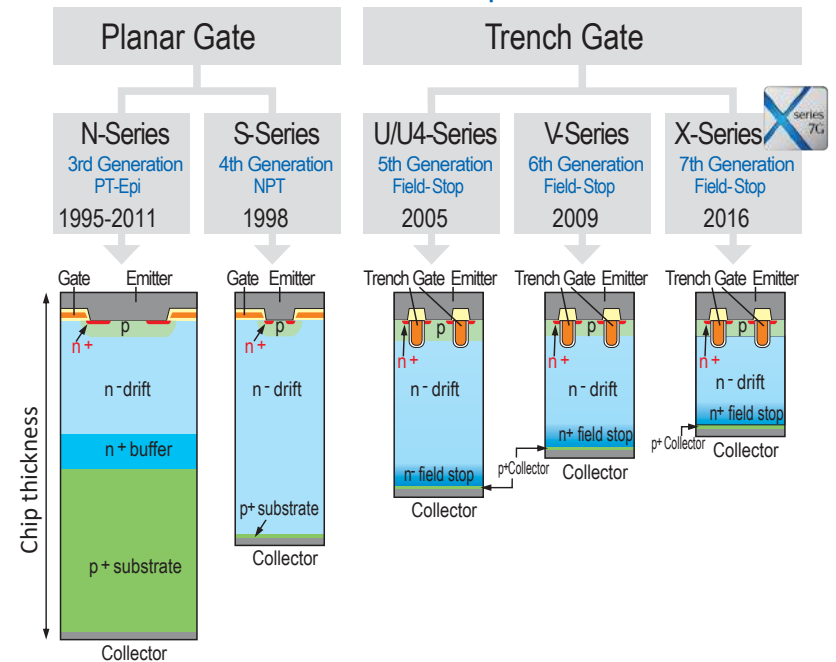

About Type Name

The Type Name is not exactly the item code for the ordering process

2. Modules with RB-IGBT (Reverse Blocking IGBT)

4 M Bi3 00 V G - 120 R1 - 50

Voltage class of inverter part

060= 600V
120=1200V
170=1700V

R = 600V
R1= 900V
R2=1200V

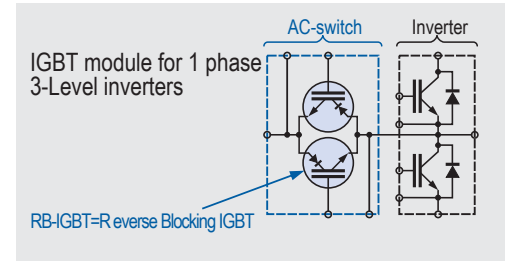

3. Discrete IGBTs

F G W 35 N 60 H D

Fuji IGBT
Package
 I_c [A] N-channel
Series
Voltage: $60=600V \cdot 65=650V \cdot 120=1200V$

4. Super- Junction MOSFETs

F M P 60 N 133 S2 FD

Fuji MOSFET
N-channel
With built-in FRED
Super- Junction MOSFET, S2-Series
 $R_{DS(on),max}$ [mW]
 V_{DS} : $60= 600V \cdot 65= 650V$
Package

5. SiC Schottky Barrier Diodes

F D C P 25 S 65

Fuji SiC-Diode
Package
Voltage: $65=650V \cdot 120=1200V$
 I_{FAV} [A]
Configuration C=Dual  S=Single 

IGBT -Modules for 3-Level Inverters

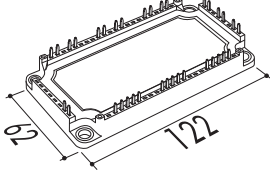
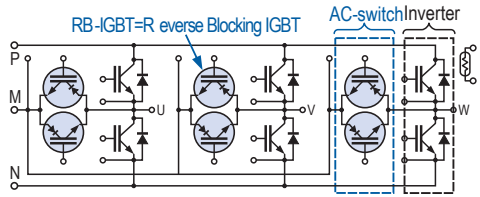
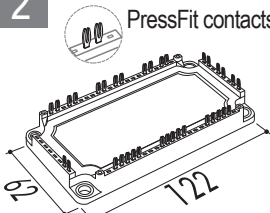
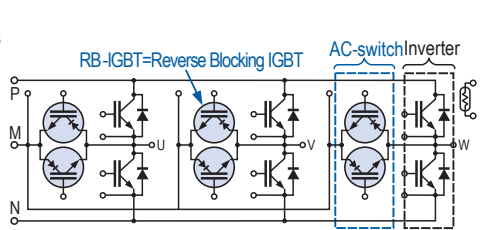
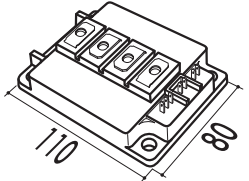
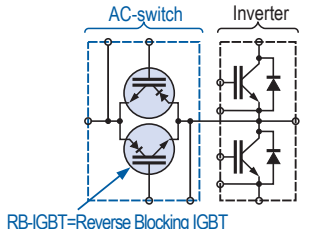
		600V		1200V		1700V	
		V-Series 6th Generation	AC-switch	V-Series 6th Generation	AC-switch	V-Series 6th Generation	AC-switch
3 Phase	1 Solder pins  M1203 	50A		12MBi 50VN-120-50	600V		
		75A		12MBi 75VN-120-50	600V		
		100A		12MBi 100VN-120-50	600V		
	2 PressFit contacts  M1202 	50A		12MBi 50VX-120-50	600V		
		75A		12MBi 75VX-120-50	600V		
		100A		12MBi 100VX-120-50	600V		
1 Phase	3  M403 	220A				4MBi 220VF-170R2-50	1200V
		300A		4MBi 300VG-120R-50	600V		
		340A		4MBi 300VG-120R1-50	900V		
		400A	4MBi 340VF-120R-50	600V	4MBi 400VF-120R-50	600V	

IGBT -Modules for 3-Level Inverters

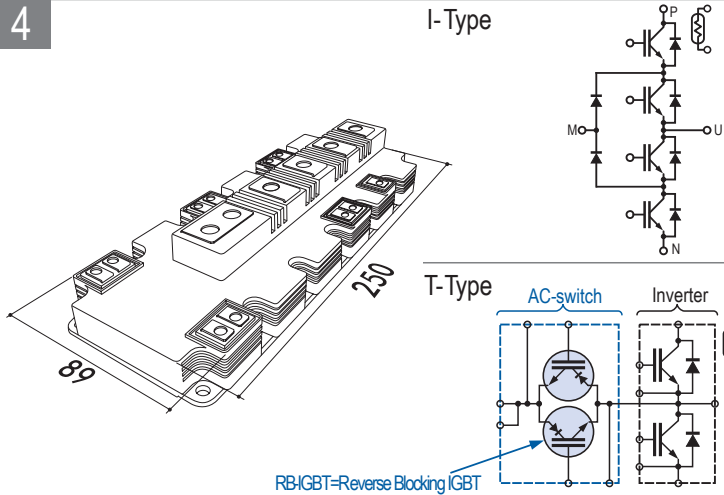

		I_C	1200V		1700V	
			V-Series 6th Generation	AC-switch	V-Series 6th Generation	AC-switch
1 Phase	4	600A	4MBi600VC-120-50			
	600A			4MBi600VB-170R2-50	1200V	
	650A	4MBi650VB-120R1-50	900V			
	900A	4MBi900VB-120R1-50	900V			



AC - switch

		I_C	1200V
			V-Series 6th Generation
2-Pack	5	450A	2MBi450VH-120F-50

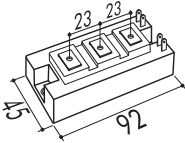
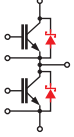
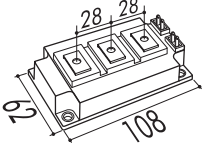
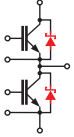
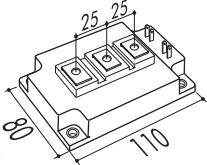
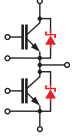
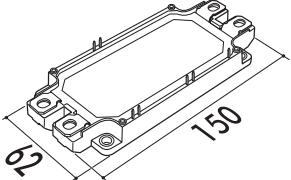
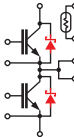
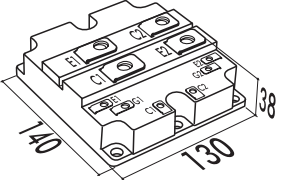
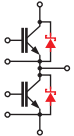

Hybrid IGBT-Modules with SiC-SBD 			I_C	1200V	1700V	
				V-Series 6th Generation	V-Series 6th Generation	
2-Pack	6			200A	2MSi 200VAB-120-53	
	7			300A	2MSi 300VAH-120C-53	
	8	 M277		400A		2MSi 400VAE-170-53
	9			300A	2MSi 300VAN-120-53*	
				450A	2MSi 450VAN-120-53*	2MSi 450VAN-170-53*
550A					2MSi 550VAN-170-53*	
600A	2MSi 600VAN-120-53*					
10			1200A		2MSi 1200VAF-170 PC* 2MSi 1200VAF-170 EC*	

Suffix -53 = With $V_{CE,sat}$ & V_F rank label

* Under Development

Hybrid IGBT-Modules with SiC-SBD

			600V	1200V
			V-Series 6th Generation	V-Series 6th Generation
PIM	11		35A	7MSR 35VB-120-50
			50A	7MSR 50VB-060-50
			75A	7MSR 75VB-060-50
			100A	7MSR 100VB-060-50
6-Pack	12		100A	6MSi 100VB-120-50

All SiC 2in1modules (SiC MOS-FET & SiC Schottky diode)

				1st gen. Trench MOS
2-Pack	13		25A	2CSi 25CAN120A-50 *
			50A	2CSi 50CAN120A-50 *
	14		75A	2CSi 75CAM120A-50 *
			100A	2CSi 100CAM120A-50 *
	15		200A	2CSi 200CAS120A-50 *
			300A	2CSi 300CAS120A-50 *
		400A	2CSi 400CAS120A-50 *	

* Under development

Small PIM IGBTs (Power Integrated Modules)

		600V	650V	1200V	
		V-Series 6th Generation	X-Series 7th Generation	V-Series 6th Generation	X-Series 7th Generation
With PressFit Contacts	16 M726	10A 7MBR 10VKA-060-50	15A 7MBR 15VKA-060-50	20A 7MBR 20VKA-060-50	25A 7MBR 25XKA120-50
	17 M727	30A 7MBR 30VKA-060-50	15A 7MBR 15VKB-120-50	25A 7MBR 25VKB-120-50	35A 7MBR 35VKB-120-50
		50A 7MBR 50VKB-060-50	10A 7MBR 10VKB-120-50	15A 7MBR 15VKB-120-50	20A 7MBR 20VKB-120-50
		25A 7MBR 25XKB120-50	30A 7MBR 30VKB-120-50	35A 7MBR 35VKB-120-50	50A 7MBR 50XKB065-50
		50A 7MBR 50XKB065-50	10A 7MBR 10VKA-120-50	15A 7MBR 15VKA-120-50	20A 7MBR 20VKA-120-50
With Solder Pins	18 M728	10A 7MBR 10VKA-060-50	15A 7MBR 15VKA-060-50	20A 7MBR 20VKA-060-50	25A 7MBR 25XKA120-50
		30A 7MBR 30VKA-060-50	15A 7MBR 15VKB-120-50	25A 7MBR 25VKB-120-50	35A 7MBR 35VKB-120-50
		50A 7MBR 50VKB-060-50	10A 7MBR 10VKB-120-50	15A 7MBR 15VKB-120-50	20A 7MBR 20VKB-120-50
		25A 7MBR 25XKB120-50	30A 7MBR 30VKB-120-50	35A 7MBR 35VKB-120-50	50A 7MBR 50XKB065-50
		50A 7MBR 50XKB065-50	10A 7MBR 10VKA-120-50	15A 7MBR 15VKA-120-50	20A 7MBR 20VKA-120-50
19 M729	15A 7MBR 15VKB-120-50	25A 7MBR 25VKB-120-50	35A 7MBR 35VKB-120-50	50A 7MBR 50XKB065-50	
	25A 7MBR 25VKB-120-50	35A 7MBR 35VKB-120-50	50A 7MBR 50XKB065-50		
	35A 7MBR 35VKB-120-50	50A 7MBR 50XKB065-50			
	50A 7MBR 50XKB065-50				

PIM and 6-PACK IGBTs with V-Series IGBT (MiniSKiiP® compatible)

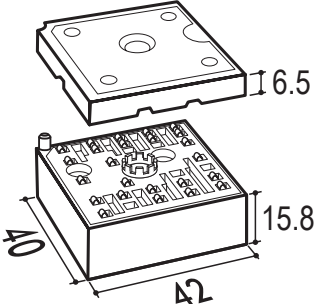
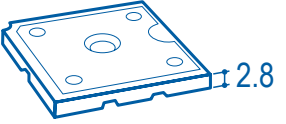
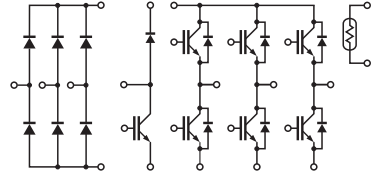
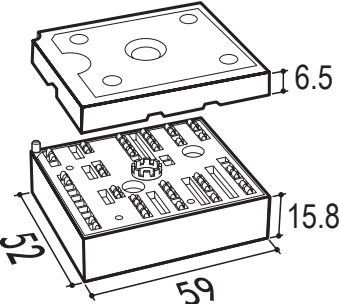
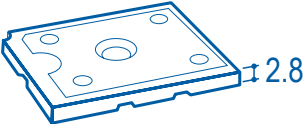
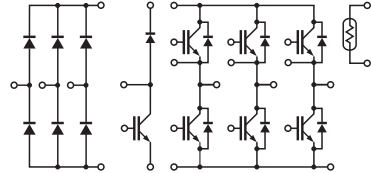
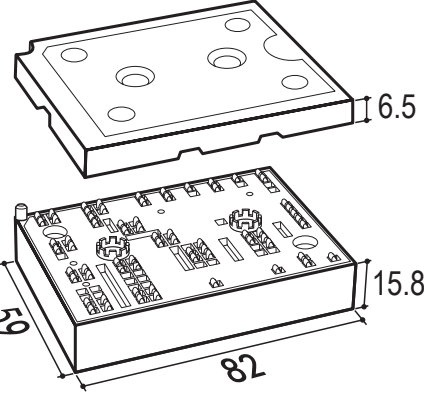
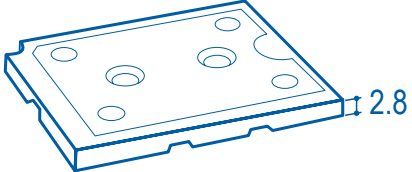
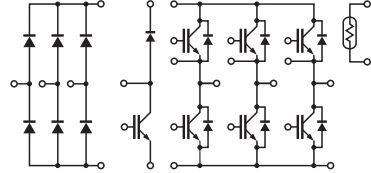
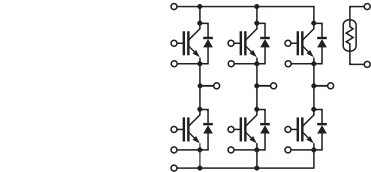
						I_C	1200V V-Series 6th Generation
MiniSKiiP® 1	20	Standard lid → Suffix= -50 	Slim lid → Suffix= -53 	PIM-IGBT 		8A	7MBR 8VJA-120-50 7MBR 8VJA-120-53
						15A	7MBR 15VJA-120-50 7MBR 15VJA-120-53
MiniSKiiP® 2	21	Standard lid → Suffix= -50 	Slim lid → Suffix= -53 	PIM-IGBT 		25A	7MBR 25VJB-120-50 7MBR 25VJB-120-53
						35A	7MBR 35VJB-120-50 7MBR 35VJB-120-53 7MBR 35VJB-120A-50 <i>With larger rectifier diodes</i> 7MBR 35VJB-120A-53 <i>With larger rectifier diodes</i>
MiniSKiiP® 3	22	Standard lid → Suffix= -50 	Slim lid → Suffix= -53 	PIM-IGBT 		50A	7MBR 50VJC-120-50 7MBR 50VJC-120-53
						75A	7MBR 75VJC-120-50 7MBR 75VJC-120-53
				6-PACK-IGBT 		100A	7MBR 100VJC-120-50 7MBR 100VJC-120-53
						100A	6MBi 100VJC-120-50* 6MBi 100VJC-120-53*
150A	6MBi 150VJC-120-50* 6MBi 150VJC-120-53* 6MBi 150VJC-120-55* <i>With SiN-DCB</i>						

MiniSKiiP® is a trademark of SEMIKRON Elektronik GmbH & Co. KG - Germany

* Under development

PIM IGBTs (Power Integrated Modules) with Solder Pins

With Solder Pins

I_C	600V	650V	1200V	
	V-Series 6th Generation	X-Series 7th Generation	V-Series 6th Generation	X-Series 7th Generation
23	25A		7MBR 25VA-120-50	
	35A		7MBR 35VA-120-50	
	50A	7MBR 50VA-060-50		
24	35A		7MBR 35VB-120-50	
	50A		7MBR 50VB-120-50	
	75A	7MBR 75VB-060-50	7MBR 75VB-120-50	
	100A	7MBR 100VB-060-50		
25	25A		7MBR 25VM-120-50	
	35A		7MBR 35VM-120-50	7MBR 35XMA120-50
	50A	7MBR 50XMA065-50	7MBR 50VM-120-50	7MBR 50XMA120-50
	75A	7MBR 75XMA065-50		7MBR 75XME120-50
26	25A		7MBR 25VP-120-50	
	35A		7MBR 35VP-120-50	7MBR 35XPA120-50
	50A	7MBR 50VP-060-50	7MBR 50XPA065-50	7MBR 50XPA120-50
	75A	7MBR 75VP-060-50	7MBR 75XPA065-50	7MBR 75XPE120-50
	100A	7MBR 100VP-060-50	7MBR 100XPE065-50	
27	50A		7MBR 50VN-120-50	
	75A		7MBR 75VN-120-50	7MBR 75XNA120-50
	100A		7MBR 100VN-120-50	7MBR 100XNA120-50
	150A		7MBR 150VN-120-50	7MBR 150XNE120-50
28	50A		7MBR 50VR-120-50	
	75A		7MBR 75VR-120-50	7MBR 75XRA120-50
	100A	7MBR 100VR-060-50	7MBR 100XRA065-50	7MBR 100XRA120-50
	150A	7MBR 150VR-060-50	7MBR 150XRA065-50	7MBR 150XRE120-50

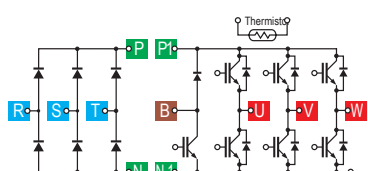
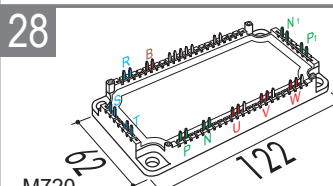
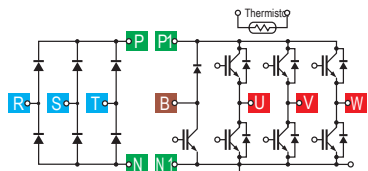
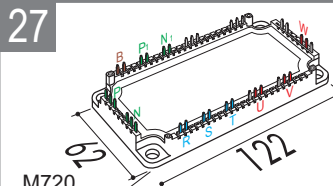
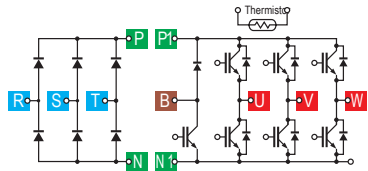
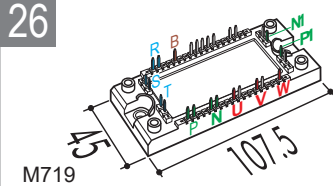
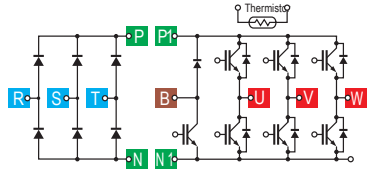
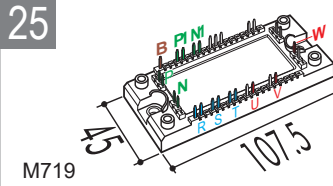
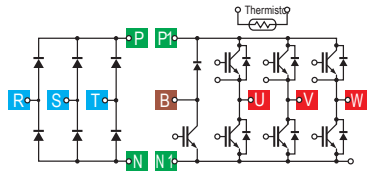
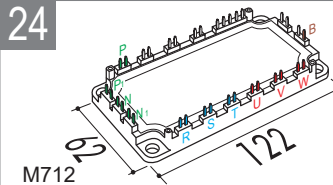
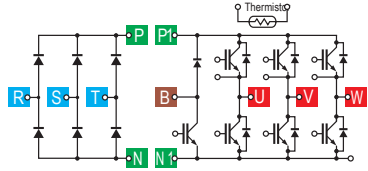
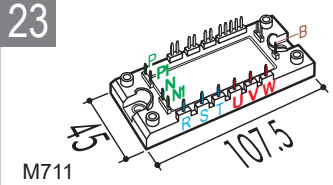

PIM IGBTs (Power Integrated Modules) with PressFit Contacts

With PressFit Contacts

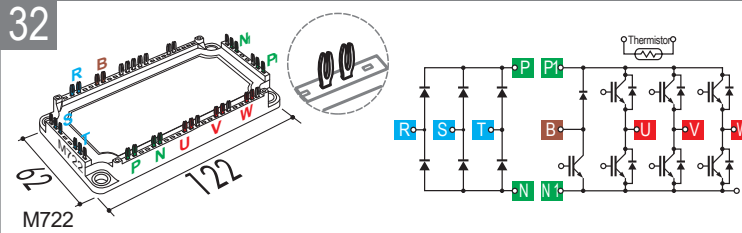
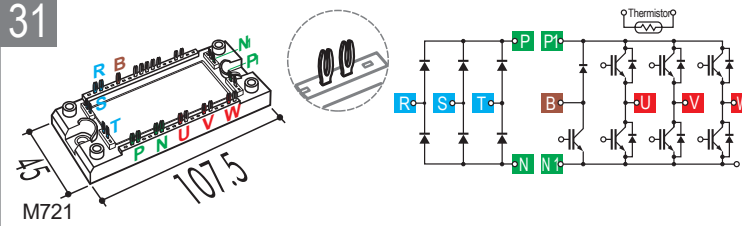
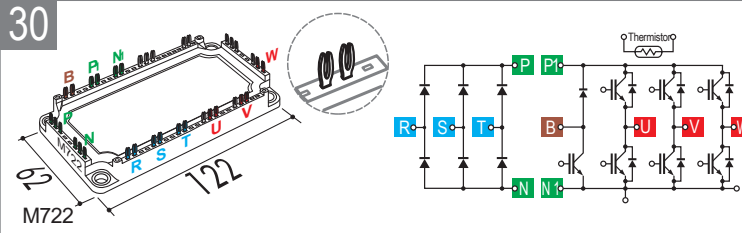
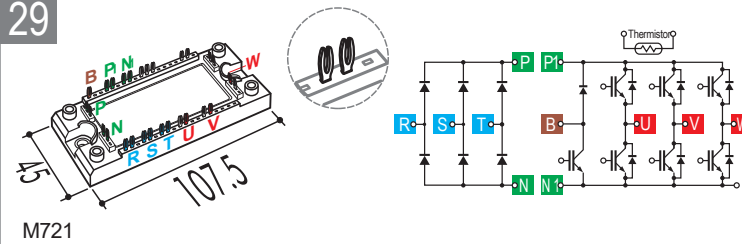

I_C	600V	650V	1200V	
	V-Series 6th Generation	X-Series 7th Generation	V-Series 6th Generation	X-Series 7th Generation
25A		7MBR 50XWA065-50	7MBR 25VW-120-50	
35A			7MBR 35VW-120-50	7MBR 35XWA120-50
50A			7MBR 50VW-120-50	7MBR 50XWA120-50
75A		7MBR 75XWA065-50		7MBR 75XWE120-50
50A			7MBR 50VX-120-50	
75A		7MBR 75XXA065-50	7MBR 75VX-120-50	7MBR 75XXA120-50
100A		7MBR 100XXA065-50	7MBR 100VX-120-50	7MBR 100XXA120-50
150A		7MBR 150XXA065-50	7MBR 150VX-120-50	7MBR 150XXE120-50
25A			7MBR 25VY-120-50	
35A			7MBR 35VY-120-50	7MBR 35XYA120-50
50A	7MBR 50VY-060-50	7MBR 50XYA065-50	7MBR 50VY-120-50	7MBR 50XYA120-50
75A	7MBR 75VY-060-50	7MBR 75XYA065-50		7MBR 75XYE120-50
100A	7MBR 100VY-060-50	7MBR 100XYE065-50		
50A			7MBR 50VZ-120-50	
75A			7MBR 75VZ-120-50	7MBR 75XZA120-50
100A	7MBR 100VZ-060-50	7MBR 100XZA065-50	7MBR 100VZ-120-50	7MBR 100XZA120-50
150A	7MBR 150VZ-060-50	7MBR 150XZA065-50	7MBR 150VZ-120-50	7MBR 150XZE120-50

6-Pack IGBTs

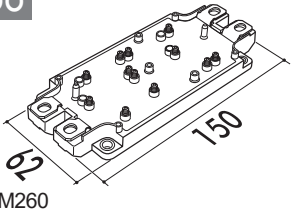
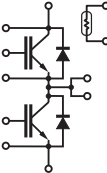
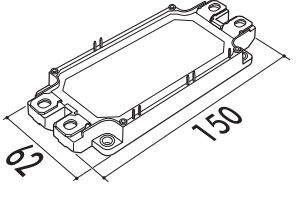
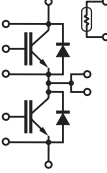
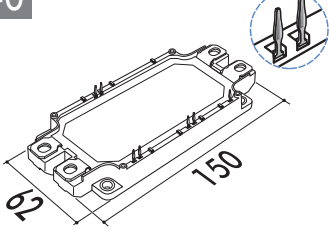
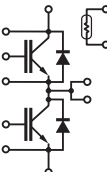

		600V		1200V		1700V	
		V-Series 6th Generation		V-Series 6th Generation		X-Series 7th Generation	
						V-Series 6th Generation	
		I_C					
With Solder Pins	33 M636		50A	6MBi 50VA-060-50	6MBi 50VA-120-50		
			75A	6MBi 75VA-060-50	6MBi 75VA-120-50		
			100A	6MBi 100VA-060-50	6MBi 100VA-120-50		
With Solder Pins	34 M633		100A		6MBi 100VB-120-50	6MBi 100XBA120-50	
			150A	6MBi 150VB-060-50	6MBi 150VB-120-50	6MBi 150XBA120-50	
			180A		6MBi 180VB-120-50		
			200A		6MBi 180VB-120-55 <i>Equivalent to 200A by lower R_{th(j-c)}</i>	6MBi 200XBA120-50 6MBi 200XBE120-50	
With PressFit Contacts	35 M647		50A	6MBi 50VW-060-50	6MBi 50VW-120-50		
			75A	6MBi 75VW-060-50	6MBi 75VW-120-50		
			100A	6MBi 100VW-060-50	6MBi 100VW-120-50		
With PressFit Contacts	36 M648		100A		6MBi 100VX-120-50	6MBi 100XXA120-50	6MBi 100VX-170-50
			150A	6MBi 150VX-060-50	6MBi 150VX-120-50	6MBi 150XXA120-50	
			180A		6MBi 180VX-120-50		
			200A		6MBi 180VX-120-55 <i>Equivalent to 200A by lower R_{th(j-c)}</i>	6MBi 200XXA120-50 6MBi 200XXE120-50	
High Power	37 M629 <i>With solder pins or with PressFit contacts</i>		225A		6MBi 225V-120-50		
			300A		6MBi 300V-120-50		6MBi 300V-170-50
			450A		6MBi 450V-120-50		6MBi 450V-170-50
			550A		6MBi 550V-120-50		6MBi 550V-170-50

2-Pack IGBT-Modules with Spring, Pin & PressFit Contacts

		1200V			1700		
		V-Series 6th Generation	V-Series 6th Generation With SiN-substrate 20% Lower thermal impedance	X-Series 7th Generation	V-Series 6th Generation	X-Series 7th Generation	
		I_C					
Spring Contacts 38	 	225A	2MBi 225VJ-120-50				
		300A	2MBi 300VJ-120-50				
		450A	2MBi 450VJ-120-50				
		550A				2MBi 550VJ-170-50	
		600A		2MBi 600VJ-120-50			
Solder Pins 39	 	225A	2MBi 225VN-120-50	2MBi 225VN-120S-50	2MBi 225XNA120-50 *	2MBi 225XNA170-50 *	
		300A	2MBi 300VN-120-50	2MBi 300VN-120S-50	2MBi 300XNA120-50 *	2MBi 300VN-170-50	2MBi 300XNA170-50 *
		450A	2MBi 450VN-120-50	2MBi 450VN-120S-50	2MBi 450XNA120-50 *	2MBi 450VN-170-50	2MBi 450XNA170-50 *
		550A				2MBi 550VN-170-50	
		600A		2MBi 600VN-120-50	2MBi 600XNE120-50		2MBi 600XNE170-50 *
		800A			2MBi 800XNE120-50		
PressFit Contacts 40	 	225A	2MBi 225VX-120-50		2MBi 225XNB120-50 *	2MBi 225VX-170-50	2MBi 225XNB 170-50 *
		300A	2MBi 300VX-120-50		2MBi 300XNB120-50 *	2MBi 300VX-170-50	2MBi 300XNB 170-50 *
		450A	2MBi 450VX-120-50		2MBi 450XNB120-50 *	2MBi 450VX-170-50	2MBi 450XNB 170-50 *
		550A				2MBi 550VX-170-50	
		600A		2MBi 600VX-120-50	2MBi 600XNF120-50 *		2MBi 600XNF170-50 *
		800A			2MBi 800XNF120-50 *		

* Under development

Standard1 & 2-Pack

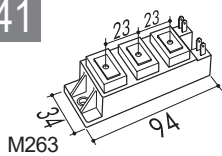
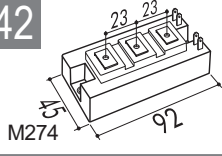
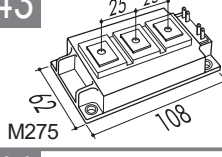
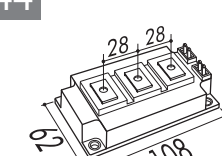
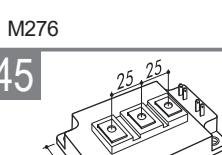
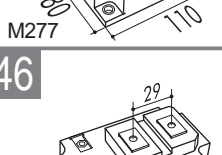

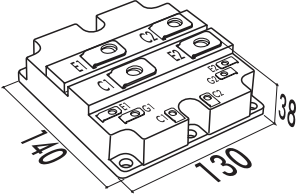
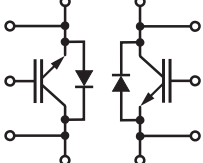
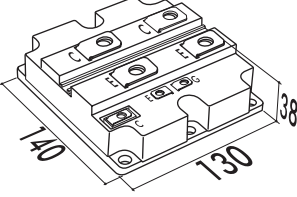
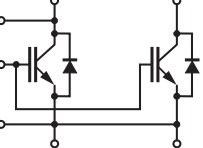
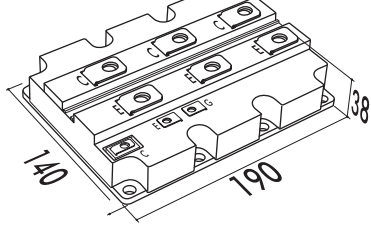
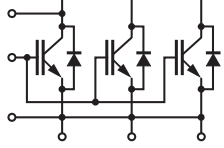

		600V	650V 	1200V 		1700V 		
		V-Series 6th Generation	X-Series 7th Generation	V-Series 6th Generation	X-Series 7th Generation	V-Series 6th Generation	X-Series 7th Generation	
Standard1 & 2-Pack	I _C							
		2-Pack	41  M263	75A			2MBi 75VA-120-50	
100A	2MBi 100VA-060-50				2MBi 100VA-120-50	2MBi 100XAA120-50*	2MBi 100VA-170-50	2MBi 100XAA170-50*
150A	2MBi 150VA-060-50			2MBi 150XAA065-50*	2MBi 150VA-120-50	2MBi 150XAA120-50*		2MBi 150XAA170-50*
200A	2MBi 200VA-060-50			2MBi 200XAA065-50*		2MBi 200XAA120-50*		
42  M274	150A				2MBi 150VB-120-50			
	200A				2MBi 200VB-120-50	2MBi 200XBE120-50*		
	300A		2MBi 300VB-060-50	2MBi 300XBE065-50		2MBi 300XBE120-50*		
	400A		2MBi 400VB-060-50	2MBi 400XBE065-50				
43  M275	300A				2MBi 300VD-120-50			
	400A		2MBi 400VD-060-50	2MBi 400XDE065-50*	2MBi 400VD-120-50	2MBi 400XDE120-50*		
	600A		2MBi 600VD-060-50	2MBi 600XDE065-50*		2MBi 600XDE120-50*		
44  M276	150A						2MBi 150VH-170-50	2MBi 150XHA170-50*
	200A				2MBi 200VH-120-50		2MBi 200VH-170-50	2MBi 200XHA170-50*
	300A				2MBi 300VH-120-50	2MBi 300XHA120-50	2MBi 300VH-170-50	2MBi 300XHA170-50*
	400A							2MBi 400XHA170-50*
	450A				2MBi 450VH-120-50	2MBi 450XHA120-50		
	600A				2MBi 600XHA120-50			
45  M277	300A			2MBi 300VE-120-50		2MBi 300VE-170-50	2MBi 300XEE170-50*	
	400A					2MBi 400VE-170-50	2MBi 400XEE170-50*	
	450A			2MBi 450VE-120-50	2MBi 450XEE120-50*			
	600A	2MBi 600VE-060-50	2MBi 600XEE065-50*	2MBi 600VE-120-50	2MBi 600XEE120-50*			
1-Pack	46  M153	300A				1MBi 300V-170-50		
		400A			1MBi 400V-120-50 1MBi 400VF-120-50	1MBi 400V-170-50		
		600A			1MBi 600V-120-50 1MBi 600VF-120-50	1MBi 600V-170-50		
		900A			1MBi 900V-120-50			

* Under development

High Power Modules 1 & 2 Pack



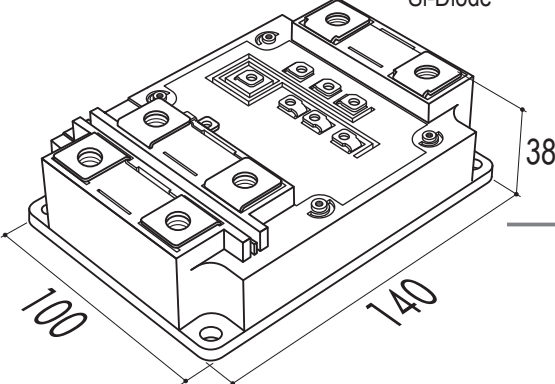
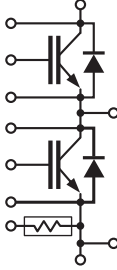
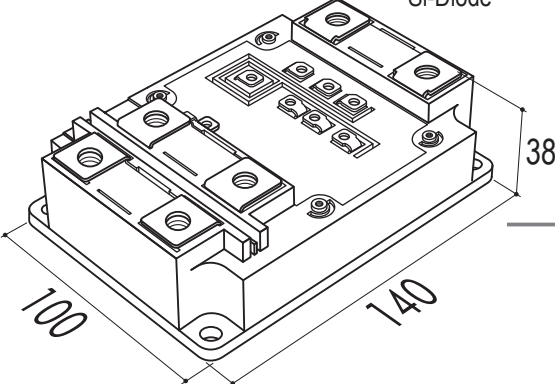

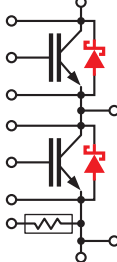

		1200V		1700V		3300V			
		V-Series 6th Generation With Cu-baseplate Soft turn-off	V-Series 6th Generation With Cu-baseplate Low switching loss	V-Series 6th Generation With AlSiC-baseplate Low switching loss	U-Series 5th Generation With AlSiC-baseplate Soft turn-off	U-Series 5th Generation With AlSiC-baseplate Low switching loss			
		I_C							
2-Pack	47	 M256, M278		600A	2MBi 600VG-120P	2MBi 600VG-170E	2MBi 600VT-170E		
				800A	2MBi 800VG-120P	2MBi 800VG-170E	2MBi 800VT-170E		
				1200A	2MBi 1200VG-120P	2MBi 1200VG-170E	2MBi 1200VT-170E		
1-Pack	48	 M151, M155		800A				1MBi 800UG-330	
				1000A				1MBi 1000UG-330	1MBi 1000UG-330B
				1200A	1MBi 1200VC-120P	1MBi 1200VC-170E	1MBi 1200VR-170E		
				1600A	1MBi 1600VC-120P	1MBi 1600VC-170E	1MBi 1600VR-170E		
				2400A	1MBi 2400VC-120P	1MBi 2400VC-170E	1MBi 2400VR-170E		
1-Pack	49	 M152, M156		1200A				1MBi 1200UE-330	
				1500A				1MBi 1500UE-330	1MBi 1500UE-330B
				2400A	1MBi 2400VD-120P	1MBi 2400VD-170E	1MBi 2400VS-170E		
				3600A	1MBi 3600VD-120P	1MBi 3600VD-170E	1MBi 3600VS-170E		

High Power next Core (HPnC)

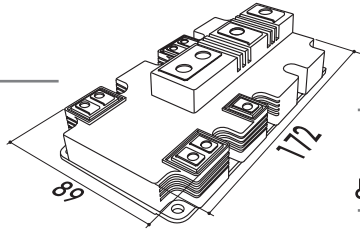
		1700V 		3300V 	
		I_C	X-Series 7th Generation	X-Series 7th Generation	
All Silicon Modules Si-IGBT & Si-Diode	 <p>50</p> <p>100</p> <p>140</p> <p>38</p> <p>All Silicon Modules Si-IGBT (X-Series, 7th Generation) Si-Diode</p> 	450A		2MBi 450XUF330-50*	
		1000A	2MBi 1000XUF170-50*		
Hybrid Modules Si-IGBT & SiC Diode	 <p>50</p> <p>100</p> <p>140</p> <p>38</p> <p>Hybrid Modules Si-IGBT (X-Series, 7th generation) SiC-Schottky Diode</p>  	450A		2MSi 450XUF330-50*	
		1000A	2MSi 1000XUF170-50*		

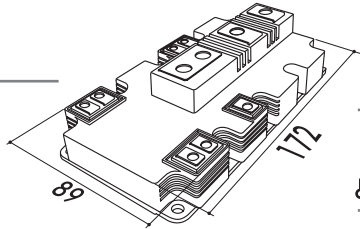
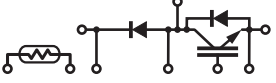
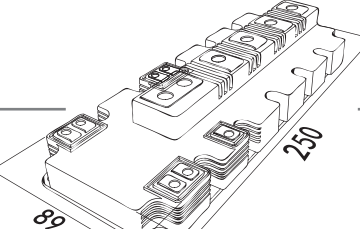
* Under development

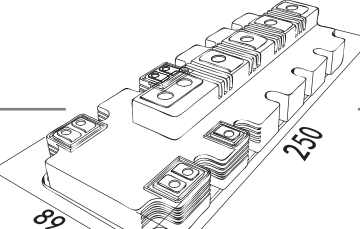
High Power Modules, 2-Pack & Chopper

		1200V		1700V			
		V-Series 6th Generation E-type (Low switching loss) P-type (Soft turn-off)	X-Series 7th Generation E-type (Low switching loss) P-type (Soft turn-off)	V-Series 6th Generation E-type (Low switching loss) P-type (Soft turn-off)	X-Series 7th Generation E-type (Low switching loss) P-type (Soft turn-off)		
2-Pack	51 		600A	2MBi 600VXA-120E-50			
			650A			2MBi 650VXA-170E-50 2MBi 650VXA-170EA-50 <i>(With larger free wheeling diode)</i>	2MBi 650XXA170E-50*
			900A	2MBi 900VXA-120E-50 2MBi 900VXA-120P-50	2MBi 900XXA120E-50* 2MBi 900XXA120P-50*		
			1200A		2MBi 1200XE120E-50* 2MBi 1200XE120P-50*		2MBi 1200XE170P-50*
Chopper	M271 		650A			1MBi 650VXA-170EL-50	
			900A	1MBi 900VXA-120PD-50			
			650A			1MBi 650VXA-170EH-50	
			900A	1MBi 900VXA-120PC-50			
2-Pack	52 		1000A			2MBi 1000VXB-170E-50 2MBi 1000VXB-170EA-50 <i>(With larger free wheeling diode)</i>	2MBi 1000XXB170E-50*
			1400A	2MBi 1400VXB-120E-50 2MBi 1400VXB-120P-50	2MBi 1400XXB120P-50*	2MBi 1400VXB-170E-50 2MBi 1400VXB-170P-50	2MBi 1400XXB170P-50*
			1800A		2MBi 1800XXF120P-50*		2MBi 1800XXF170P-50*
Chopper	M272 		1000A			1MBi 1000VXB-170EL-50	
			1400A	1MBi 1400VXB-120PL-50		1MBi 1400VXB-170EL-50	
			1000A			1MBi 1000VXB-170EH-50	
			1400A	1MBi 1400VXB-120PH-50		1MBi 1400VXB-170EH-50	



Above devices are available with $V_{CE(sat)}$ & V_F rank label for optimum paralleling (→suffix -54 instead of -50)

* Under development

IPM IGBTs (Intelligent Power Modules)

Built-in protection functions

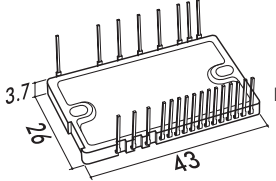
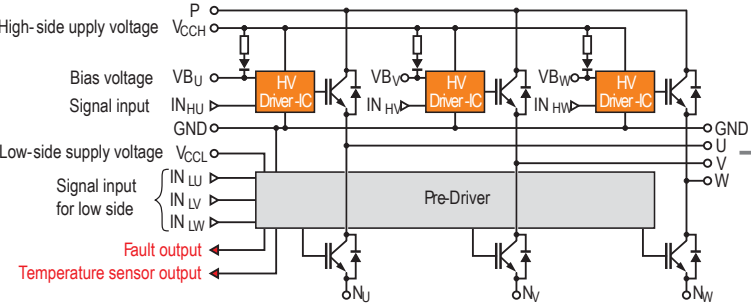
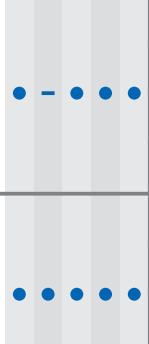
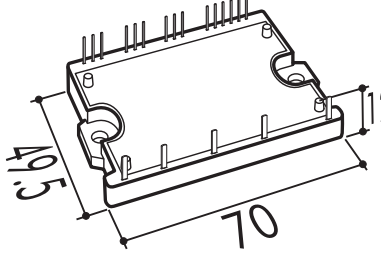
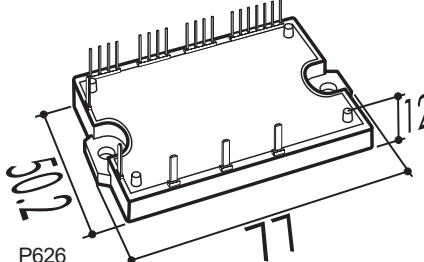
- Fault status output (Alarm)
- Under voltage protection (self shutdown)
- Short circuit protection (self shutdown)
- Overheating protection (self shutdown)
- Temperature sensor function ($V_{temp,out}$)

	Without Brake-Chopper	IC	600V		1200V		
			V-Series 6th Generation	X-Series 7th Generation		V-Series 6th Generation	
53	With High Voltage Driver-IC  	15A		6MBP 15XSD060-50			
		20A		6MBP 20XSD060-50			
		30A		6MBP 30XSD060-50			
		35A		6MBP 35XSD060-50			
		15A		6MBP 15XSF060-50			
		20A		6MBP 20XSF060-50			
		30A		6MBP 30XSF060-50			
		35A		6MBP 35XSF060-50			
		54	I_c & T_j Sensors on chip  	10A			6MBP 10VAA-120-50
				15A			6MBP 15VAA-120-50
20A	6MBP 20VAA-060-50						
25A						6MBP 25VAA-120-50	
30A	6MBP 30VAA-060-50						
50A	6MBP 50VAA-060-50						
55	I_c & T_j Sensors on chip  			25A			6MBP 25VBA-120-50
		35A			6MBP 35VBA-120-50		
		50A	6MBP 50VBA-060-50			6MBP 50VBA-120-50	
		75A	6MBP 75VBA-060-50				

IPM IGBTs (Intelligent Power Modules)

- Built-in protection functions
- Fault status output (Alarm)
 - Under voltage protection (self shutdown)
 - Short circuit protection (self shutdown)
 - Overheating protection (self shutdown)
 - Temperature sensor function ($V_{temp,out}$)

56 I_c - & T_j -Sensors on chip

Without Brake-Chopper

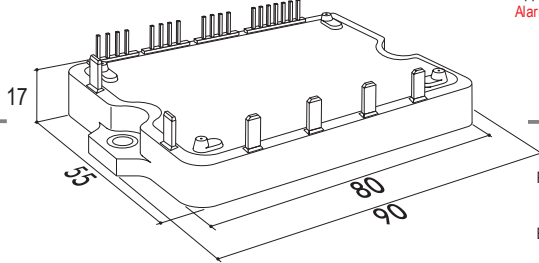

With Brake-Chopper

P636

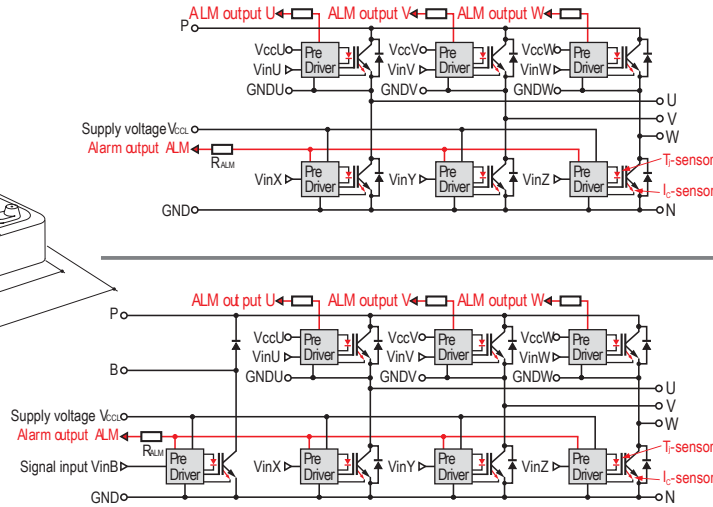

I_c	600V	1200V
	V-Series 6th Generation	V-Series 6th Generation
25A		6MBP 25VFN-120-50
35A		6MBP 35VFN-120-50
50A	6MBP 50VFN-060-50	6MBP 50VFN-120-50
75A	6MBP 75VFN-060-50	
100A	6MBP 100VFN-060-50	
25A		7MBP 25VFN-120-50
35A		7MBP 35VFN-120-50
50A	7MBP 50VFN-060-50	7MBP 50VFN-120-50
75A	7MBP 75VFN-060-50	
100A	7MBP 100VFN-060-50	

IPM IGBTs (Intelligent Power Modules)

- Built-in protection functions**
- Fault status output (Alarm)
 - Under voltage protection (self shutdown)
 - Short circuit protection (self shutdown)
 - Overheating protection (self shutdown)
 - Temperature sensor function (V_{temp.out})

			I _C	600V V-Series 6th Generation	1200V V-Series 6th Generation
Without Brake-Chopper	57 I _c - & T _j -Sensors on chip		25A		6MBP 25VDA-120-50
			35A		6MBP 35VDA-120-50
			50A	6MBP 50VDA-060-50	6MBP 50VDA-120-50 6MBP 50VDN-120-50 ¹⁾
			75A	6MBP 75VDA-060-50	6MBP 75VDA-120-50 6MBP 75VDN-120-50 ¹⁾
			100A	6MBP 100VDA-060-50 6MBP 100VDN-060-50 ¹⁾	6MBP 100VDA-120-50 6MBP 100VDN-120-50 ¹⁾
			150A	6MBP 150VDA-060-50 6MBP 150VDN-060-50 ¹⁾	
			200A	6MBP 200VDA-060-50 6MBP 200VDN-060-50 ¹⁾	
With Brake-Chopper	57 I _c - & T _j -Sensors on chip		25A		7MBP 25VDA-120-50
			35A		7MBP 35VDA-120-50
			50A	7MBP 50VDA-060-50	7MBP 50VDA-120-50 7MBP 50VDN-120-50 ¹⁾
			75A	7MBP 75VDA-060-50	7MBP 75VDA-120-50 7MBP 75VDN-120-50 ¹⁾
			100A	7MBP 100VDA-060-50 7MBP 100VDN-060-50 ¹⁾	7MBP 100VDA-120-50 7MBP 100VDN-120-50 ¹⁾
			150A	7MBP 150VDA-060-50 7MBP 150VDN-060-50 ¹⁾	
			200A	7MBP 200VDA-060-50 7MBP 200VDN-060-50 ¹⁾	
Without Brake-Chopper	58 I _c - & T _j -Sensors on chip		100A		6MBP 100VEA-120-50
			150A		6MBP 150VEA-120-50
			200A	6MBP 200VEA-060-50	6MBP 200VEA-120-50
			300A	6MBP 300VEA-060-50	
			400A	6MBP 400VEA-060-50	
With Brake-Chopper	58 I _c - & T _j -Sensors on chip		100A		7MBP 100VEA-120-50
			150A		7MBP 150VEA-120-50
			200A	7MBP 200VEA-060-50	7MBP 200VEA-120-50
			300A	7MBP 300VEA-060-50	
			400A	7MBP 400VEA-060-50	

1) With high thermal performance

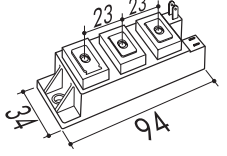
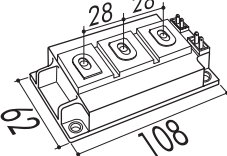
Chopper(Standard and high speed IGBTs)		I_C	1200V		
			Planar-NPT High Speed-Series	U-Series 5th Generation	V-Series 6th Generation
Chopper	59  M262	50A		1MBi 50U4F-120L-50	
		75A		1MBi 75U4F-120L-50	
		100A		1MBi 100U4F-120L-50	
	60  M259	150A			1MBi 150VA-120L-50
		200A			1MBi 200VA-120L-50
		200A	1MBi 200HH-120L-50	1MBi 200U4H-120L-50 Without thermistor	
	300A	1MBi 300HH-120L-50			
	400A	1MBi 400HH-120L-50			

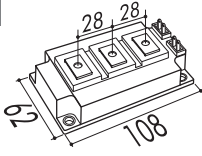
High Speed IGBTs		I_C	1200V
			Planar-NPT High Speed-Series
2-Pack	61 	100A	2MBi 100HJ-120-50
		150A	2MBi 150HJ-120-50
		200A	2MBi 200HJ-120-50
		300A	2MBi 300HJ-120-50

Discrete IGBTs

TO -247	62	Without free wheeling diode	V-Series, 6th Generation Low loss , ~10kHz		V-Series, 6th Generation High speed , 10~30kHz		W-Series, 6th Generation Ultra high speed , 20~100kHz		
			I_c		I_c		I_c		
			600V	1200V	600V	1200V	650V	1200V	
		15A				FGW 15N 120H			
		25A						FGW 25N 120W	
		30A					FGW 30N 120H		
		35A			FGW 35N 60H				
		40A				FGW 40N 120H	FGW 40N 65W	FGW 40N 120W	
		50A			FGW 50N 60H		FGW 50N 65W		
		60A					FGW 60N 65W		
		75A			FGW 75N 60H				
		15A		FGW 15N 120VD		FGW 15N 120HD			
		25A		FGW 25N 120VD				FGW 25N 120WD FGW 25N 120WE	
		30A	FGW 30N 60VD			FGW 30N 120HD	FGW 30N 65WD		
		35A			FGW 35N 60HD FGW 35N 60HC ¹⁾				
		40A		FGW 40N 120VD		FGW 40N 120HD	FGW 40N 65WD FGW 40N 65WE	FGW 40N 120WD FGW 40N 120WE	
		50A	FGW 50N 60VD		FGW 50N 60HD FGW 50N 60HC ¹⁾		FGW 50N 65WD FGW 50N 65WE		
60A					FGW 60N 65WD FGW 60N 65WE				
75A			FGW 75N 60HD FGW 75N 60HC ¹⁾		FGW 75N 65WE				

TO -247-4	63	IGBT with Kelvin connection	W-Series, 6th Generation Ultra high speed , 20~100kHz	
			650V	1200V
		40A		FGZ 40N 120WE ¹⁾
		50A	FGZ 50N 65WD FGZ 50N 65WE ¹⁾	
		75A	FGZ 75N 65WE ¹⁾	

TO -247	64	Reverse Blocking IGBT	I_c	600V
			85A	FGW 85N 60RB

1) With full rating free wheeling diode



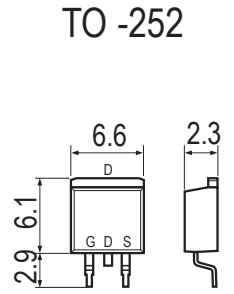
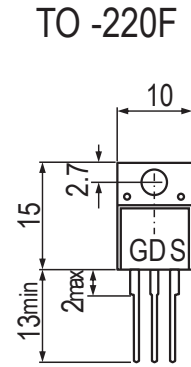
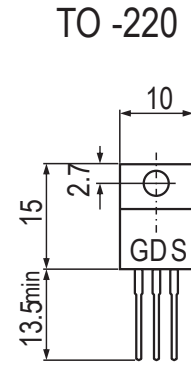
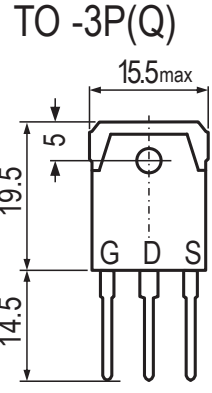
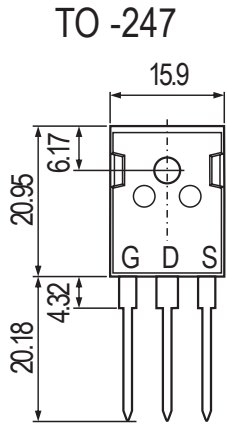





Super - Junction
MOSFET

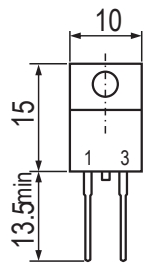
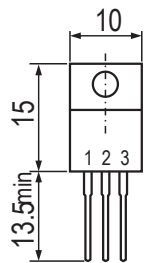
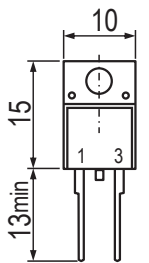
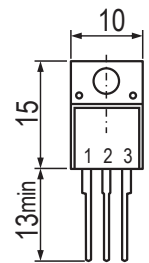
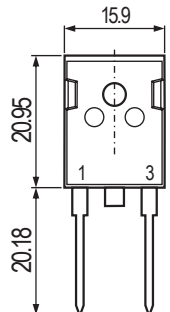
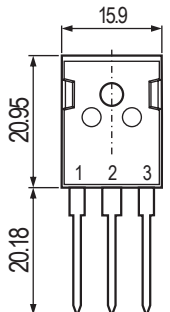
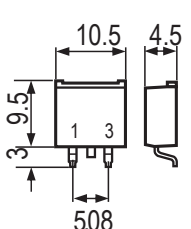
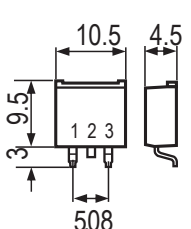

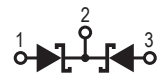
V _{DS}	R _{DS(on), max}	I _D	TO -247	TO -3P(Q)	TO -220	TO -220F	TO -252	
600V	25.4 mW	95.5 A	FM W 60N 025 S2					
	40.0 mW	66.2 A	FM W 60N 040 S2					
	55.0 mW	50.3 A	FM W 60N 055 S2					
	70.0 mW	39.4 A	FM W 60N 070 S2			FM V 60N 070 S2		
	79.0 mW	37.1 A	FM W 60N 079 S2		FM P 60N 079 S2	FM V 60N 079 S2		
	88.0 mW	32.8 A	FM W 60N 088 S2		FM P 60N 088 S2	FM V 60N 088 S2		
	99.0 mW	29.2 A	FM W 60N 099 S2		FM P 60N 099 S2	FM V 60N 099 S2		
	125.0 mW	23.4 A	FM W 60N 125 S2		FM P 60N 125 S2	FM V 60N 125 S2		
	160.0 mW	18.4 A	FM W 60N 160 S2		FM P 60N 160 S2	FM V 60N 160 S2		
	190.0 mW	15.5 A	FM W 60N 190 S2	FM H 60N 190 S2	FM P 60N 190 S2	FM V 60N 190 S2		
	280.0 mW	10.7 A		FM H 60N 280 S2	FM P 60N 280 S2	FM V 60N 280 S2	FM D 60N 280 S2	
	380.0 mW	8.1 A			FM P 60N 380 S2	FM V 60N 380 S2	FM D 60N 380 S2	
	With built-in FRED	27.0 mW	95.5 A	FM W 60N 027 S2 FD				
		43.0 mW	66.2 A	FM W 60N 043 S2 FD				
		59.0 mW	50.3 A	FM W 60N 059 S2 FD				
		75.0 mW	39.4 A	FM W 60N 075 S2 FD			FM V 60N 075 S2 FD	
		84.0 mW	37.1 A	FM W 60N 084 S2 FD		FM P 60N 084 S2 FD	FM V 60N 084 S2 FD	
94.0 mW		32.8 A	FM W 60N 094 S2 FD		FM P 60N 094 S2 FD	FM V 60N 094 S2 FD		
105.0 mW		29.2 A	FM W 60N 105 S2 FD		FM P 60N 105 S2 FD	FM V 60N 105 S2 FD		
133.0 mW		23.4 A	FM W 60N 133 S2 FD		FM P 60N 133 S2 FD	FM V 60N 133 S2 FD		
170.0 mW	18.4 A	FM W 60N 170 S2 FD		FM P 60N 170 S2 FD	FM V 60N 170 S2 FD			

* Under development

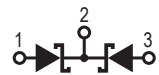
SiC Schottky Barrier Diodes 

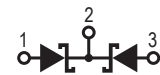
		TO -220		TO -220F (insulated)		TO -247		T-Pack S	
									
		Single	Dual	Single	Dual	Single	Dual	Single	Dual
I_{FAV}									
650V	10A	FDCP 10S 65		FDCA 10S 65		FDCY 10S 65		FDCC 10S 65	
	20A		FDCP 20C 65		FDCA 20C 65		FDCY 20C 65		FDCC 20C 65
	25A	FDCP 25S 65		FDCA 25S 65		FDCY 25S 65		FDCC 25S 65	
	50A					FDCY 50C 65			
1200V	18A			FDCA 18S 120		FDCY 18S 120			
	36A					FDCY 36C 120			

Fuji Electric Corp of America (FEA) Semiconductor Sales Network

FEA Sales Offices

Edison, NJ (HQ)

732-952-8146
x-fea-semi-group@fujielctric.com

Dallas, TX

732-600-6309
lfick@fujielctric.com

Ithaca, NY

607-266-9494
jusack@fujielctric.com

Milwaukee, WI

262-547-0185
ttwitchell@fujielctric.com

Discrete Parts

214-675-6532
cmerz@fujielctric.com

FEA Sales Representatives- United States and Territories

Alabama

Cartwright & Bean
770-416-6075
sales@cartbean.com
www.cart-bean.com

Alaska

FEA
732-600-6309
lfick@fujielctric.com
americas.fujielctric.com

Arizona

FEA
732-600-6309
lfick@fujielctric.com
americas.fujielctric.com

Arkansas

Centramark
972-414-8188
insidesales@cmatex.com
www.cmatex.com

California- North of San Luis Obispo

MicroElec Technical
408-282-3508
sales@microelecs.com
www.microelecs.com

California- San Luis Obispo and South

S.A. Larson & Associates
626-793-4411
sales@salarson.com
www.salarson.com

Colorado

FEA
732-600-6309
lfick@fujielctric.com
americas.fujielctric.com

Connecticut

Conti-Younger Associates
860-668-7956
sales@conti-younger.com
www.conti-younger.com

Delaware

GSA Sales
215-335-4600
cfranklin@gsarepsales.com
www.gsatech.com

District of Columbia

GSA Sales
215-335-4600
cfranklin@gsarepsales.com
www.gsatech.com

Florida

Moats Yates & Associates
305-733-4941
cmoats777@aol.com
www.moatsyates.com

Georgia

Cartwright & Bean
770-416-6075
sales@cartbean.com
www.cart-bean.com

Hawaii

MicroElec Technical
408-282-3508
sales@microelecs.com
www.microelecs.com

Idaho

FEA
732-600-6309
lfick@fujielctric.com
americas.fujielctric.com

Illinois

FEA
262-547-0185
ttwitchell@fujielctric.com
americas.fujielctric.com

Indiana

Palladium Tech
317-487-9303
jim@junctiontech.com
www.palladiumtech.com

Iowa

FEA
732-600-6309
lfick@fujielctric.com
americas.fujielctric.com

Kansas

FEA
262-547-0185
ttwitchell@fujielctric.com
americas.fujielctric.com

Kentucky

Palladium Tech
937-339-4750
gskipper@palladiumtech.com
www.palladiumtech.com

Louisiana

Centramark
972-414-8188
insidesales@cmatex.com
www.cmatex.com

Maine

Conti-Younger Associates
508-485-7204
sales@conti-younger.com
www.conti-younger.com

Maryland

GSA Sales
215-335-4600
cfranklin@gsarepsales.com
www.gsatech.com

Massachusetts

Conti-Younger Associates
508-485-7204
sales@conti-younger.com
www.conti-younger.com

Michigan

Palladium Tech
810-695-0665
intercomm.carl@yahoo.com
www.palladiumtech.com

Minnesota

RCOM
763-557-2801
warrent@rcominc.com
www.rcominc.com

Mississippi

Cartwright & Bean
770-416-6075
sales@cartbean.com
www.cart-bean.com

Missouri

FEA
262-547-0185
ttwitchell@fujielctric.com
americas.fujielctric.com

Montana

FEA
732-600-6309
lfick@fujielctric.com
americas.fujielctric.com

Nebraska

FEA
262-547-0185
ttwitchell@fujielctric.com
americas.fujielctric.com

Nevada

MicroElec Technical
408-282-3508
sales@microelecs.com
www.microelecs.com

New Hampshire

Conti-Younger Associates
508-485-7204
sales@conti-younger.com
www.conti-younger.com

New Jersey

GSA Sales
215-335-4600
cfranklin@gsarepsales.com
www.gsatech.com

New Mexico

FEA
732-600-6309
lfick@fujielctric.com
americas.fujielctric.com

New York- Greater NYC

GSA Sales
215-335-4600
cfranklin@gsarepsales.com
www.gsatech.com

New York- Upstate

ICS Solutions
315-374-2731
tlongo@ics-solutions.org
americas.fujielctric.com

North Carolina

Cartwright & Bean
770-416-6075
sales@cartbean.com
www.cart-bean.com

North Dakota

RCOM
763-557-2801
warrent@rcominc.com
www.rcominc.com

Ohio

Palladium Tech
937-339-4750
gskipper@palladiumtech.com
www.palladiumtech.com

Oklahoma

Centramark
972-414-8188
insidesales@cmatex.com
www.cmatex.com

Oregon

FEA
732-600-6309
lfick@fujielctric.com
americas.fujielctric.com

Pennsylvania- Eastern

GSA Sales
215-335-4600
cfranklin@gsarepsales.com
www.gsatech.com

Pennsylvania- Western

RK Miller & Associates
724-612-6123
rmiller@rkmallc.com

Puerto Rico

FEA
607-266-9494
jusack@fujielctric.com
americas.fujielctric.com

Rhode Island

Conti-Younger Associates
860-668-7956
sales@conti-younger.com
www.conti-younger.com

South Carolina

Cartwright & Bean
770-416-6075
sales@cartbean.com
www.cart-bean.com

South Dakota

RCOM
763-557-2801
warrent@rcominc.com
www.rcominc.com

Tennessee

Cartwright & Bean
770-416-6075
sales@cartbean.com
www.cart-bean.com

Texas

Centramark
972-414-8188
insidesales@cmatex.com
www.cmatex.com

Utah

FEA
732-600-6309
lfick@fujielctric.com
americas.fujielctric.com

Vermont

Conti-Younger Associates
508-485-7204
sales@conti-younger.com
www.conti-younger.com

Virgin Islands

FEA
607-266-9494
jusack@fujielctric.com
americas.fujielctric.com

Virginia

GSA Sales
215-335-4600
cfranklin@gsarepsales.com
www.gsatech.com

Washington

FEA
732-600-6309
lfick@fujielctric.com
americas.fujielctric.com

West Virginia

RK Miller & Associates
724-612-6123
rmiller@rkmallc.com

Wisconsin

RCOM
763-557-2801
warrent@rcominc.com
www.rcominc.com

Wyoming

FEA
732-600-6309
lfick@fujielctric.com
americas.fujielctric.com

FEA Sales Representatives

Canada

Sigma Component Design
905-696-8800
sales@sigmacomponent.com
www.sigmacomponent.com

Mexico

FEA
607-266-9494
jusack@fujielctric.com
americas.fujielctric.com

Central America

FEA
607-266-9494
jusack@fujielctric.com
americas.fujielctric.com

South America

FEA
607-266-9494
jusack@fujielctric.com
americas.fujielctric.com

FEA Distributors

Brazil Distributor

Richardson Electronics do Brasil
+55 11 5186 9663
enio@rell.com
www.rell.com

Brazil Distributor

TCT- Terceirizaacao Com e Technol em Semiconds. LTDA
011+55-11-5545-9400
vendas@tctbrasil.com.br
www.tctbrasil.com.br

North America

Richardson Electronics
630-208-2200
sales@rell.com
www.rell.com

North & South America excluding Brazil

New Advantage Corporation
727-828-0187
sales@nacsemi.com
nacsemi.com

North America Discrete Parts

Allied Electronics
866-433-5722
www.alliedelec.com



Fuji Electric Corp of America
50 Northfield Avenue
Edison, NJ 08837
Tel: +1 732-952-8146
email: x-fea-semi-group@fujielctric.com
americas.fujielctric.com



Fuji Electric Corp. of America
50 Northfield Avenue
Edison, NJ 08837 USA
Tel: 732-560-9410
www.americas.fujielectric.com

Power Semiconductors Group

<https://americas.fujielectric.com/products/semiconductors/>

Fuji Electric Hong Kong Co., Limited
Unit 227-230, 2nd Floor, No.1 Science Park West Avenue,
Hong Kong Science Park, Shatin, N.T., Hong Kong.
Tel: +852-2664-8699

Fuji Electric Taiwan Co., Ltd.
F9-1 , No. 111 , Sung Chiang Road, Taipei, TAIWAN
Tel: +886-2-2515-1850

Fuji Electric Asia Pacific Private Ltd.
171 Chin Swee Road,#12-01 ,San Centre,SINGAPORE 169877
Tel: +65-6533-0014

Fuji Electric (China) Co., Ltd
F27, International Corporate City, NO.3000 Zhongshan North Road,
Shanghai 200063 P.R.C., CHINA
Tel: +86-21-5496-1177

Fuji Electric India Private Ltd.
409 &410, Meadows, Sahar Plaza, J.B. Nagar, Andheri-Kurla Road,
Andheri(East), Mumbai - 400 059, India
Tel: +91-22-4010-4870

Fuji Electric Europe GmbH
Goethering 58, 63067 Offenbach, am Main, F.R. GERMANY
Tel: +49-69-6690290

Information in this catalog is subject to change without notice.

Fuji, fujitsu, Минск +375447584780

www.fotorele.net www.tiristor.by радиодетали, электронные компоненты
email minsk17@tut.by tel.+375 29 758 47 80 МТС

каталог, описание, технические, характеристики, datasheet, параметры,
маркировка, габариты, фото, модуль, Fuji, fujitsu, реле

КАТАЛОГ

модуль , igbt, мост диодный, реле

купить, продажа

электронные компоненты

Мы не работаем с частными (физическими) лицами. Мы работаем только с юридическими
лицами(организациями) и ИП и только по безналичному расчёту.

[где и как купить в Минске?](#)

