

каталог, описание, технические, характеристики, datasheet, однофазный, трёхфазный,
параметры, маркировка, габариты, фото, skbpc, skbpc5010, даташит, аналог, замена

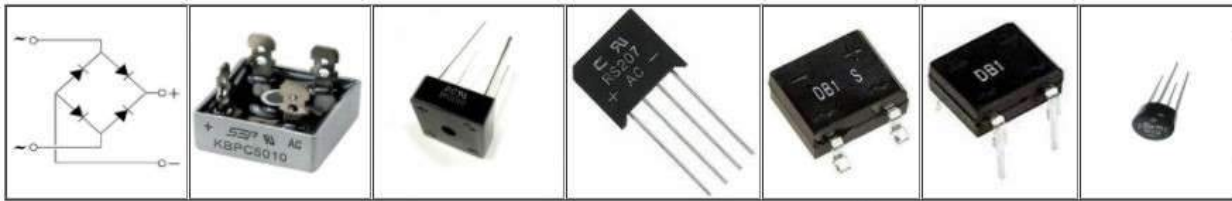

Диодные мосты
однофазные KBPC



Диодные мосты
однофазные QL



Диодные мосты
трёхфазные SQL



Диодные мосты
однофазные MDQ



Диодные мосты
трёхфазные MDS



Диодные мосты
однофазные DF10M

Минск www.fotorele.net www.tiristor.by
email minsk17@tut.by тел.+375447584780
и другие, радиодетали, электронные компоненты
каталог, описание, технические, характеристики,
datasheet,
параметры, маркировка, габариты, фото, аналог,
замена
смотрите ниже

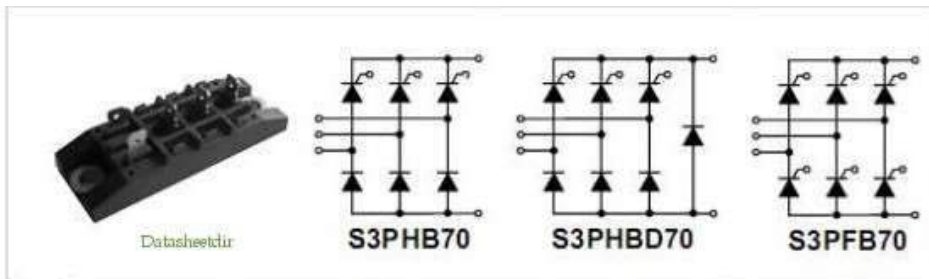

Трёхфазные полностью управляемые мосты

Трёхфазные полууправляемые мосты

Трёхфазные полууправляемые мосты с разрядным

Трёхфазные тиристорные модули с общим анодом

Однофазные выпрямительные мосты

Трёхфазные выпрямительные мосты

Диодный мост, выпрямители

Suntan является производителем мостовых выпрямителей в Гонконге. Посвящается разработке, выпуску и маркетингу всего диапазона мостового выпрямителя, который все признаны UL, и имеют собственный зарегистрированный бренд Su, который можно легко настроить в соответствии с вашими требованиями к цепи.

Su Bridge Rectifiers Фотографии



ABS10



MB10S



DB107



DB107S



KBP210



RS207



KBL410



GBU410



W10

Минск www.fotorele.net www.tiristor.by email mink17@tut.by тел.+375447584780



GBJ610



KBJ610



KBU610



BR2510W



BR2510



SKBPC2516



SKBPC3516



KBPC2510W



KBPC2510



KBPC3510W



KBPC3510

г. Минск www.fotorele.net www.tiristor.by email minsk17@tut.by тел.+375447584780

Su Bridge Выпрямители Список: UL No.E347215

- (W005-W10)Single Phase 1.0 AMPS. Стекло пассивированные мостовые выпрямители
- (MB1F-MB10F)Single Phase 1.0 AMPS. Стекло пассивированные мостовые выпрямители
- (ABS1-ABS10)Однофазный 1,0 AMPS. Стекло пассивированные мостовые выпрямители
- (MB1S-MB10S)Single Phase 1.0 AMPS. Стекло пассивированные мостовые выпрямители
- (DB101-DB107)Single Phase 1.0 AMPS. Стекло пассивированные мостовые выпрямители
- (DB101S-DB107S)Single Phase 1.0 AMPS. Стекло пассивированные мостовые выпрямители
- (DB151-DB157)Однофазный 1,5 AMPS. Стекло пассивированные мостовые выпрямители
- (DB151S-DB157S)Однофазный 1,5 AMPS. Стекло пассивированные мостовые выпрямители
- (RS201-RS207)Однофазный 2,0 AMPS. Стекло пассивированные мостовые выпрямители
- (KBP2005-KBP210)Single Phase 2.0 AMPS. Стекло пассивированные мостовые выпрямители
- (KBL4005-KBL410)Single Phase 4.0 AMPS. Стекло пассивированные мостовые выпрямители
- (KBU6005-KBU610)Single Phase 6.0 AMPS. Стекло пассивированные мостовые выпрямители
- (GBU4005-GBU410)Single Phase 4.0 AMPS. Стекло пассивированные мостовые выпрямители
- (GBU6005-GBU610)Однофазное 6.0 AMPS. Стекло пассивированные мостовые выпрямители
- (GBU8005-GBU810)Single Phase 8.0 AMPS. Стекло пассивированные мостовые выпрямители
- (GBU10005-GBU1010)Однофазное 10,0 AMPS. Стекло пассивированные мостовые выпрямители
- (GBU15005-GBU1510)Single Phase 15.0 AMPS. Стекло пассивированные мостовые выпрямители
- (KBJ6005-KBJ610)Single Phase 6.0 AMPS. Стекло пассивированные мостовые выпрямители
- (GBJ6005-GBJ610)Однофазное 6.0 AMPS. Стекло пассивированные мостовые выпрямители
- (GBJ801-GBJ810)Однофазный 8,0 AMPS. Стекло пассивированные мостовые выпрямители
- (GBJ10005-GBJ1010)Однофазный 10,0 AMPS. Стекло пассивированные мостовые выпрямители
- (GBJ15005-GBJ1510)Single Phase 15.0 AMPS. Стекло пассивированные мостовые выпрямители
- (GBJ20005-GBJ2010)Однофазная 20,0 AMPS. Стекло пассивированные мостовые выпрямители
- (GBJ25005-GBJ2510)Однофазный 25,0 AMPS. Стекло пассивированные мостовые выпрямители
- (GBJ35005-GBJ3510)Однофазный 35,0 AMPS. Стекло пассивированные мостовые выпрямители
- (KBPC6005-KBPC610)Single Phase 6.0 AMPS. Стекло пассивированные мостовые выпрямители
- (KBPC8005-KBPC810)Single Phase 8.0 AMPS. Стекло пассивированные мостовые выпрямители
- (KBPC10005-KBPC1010)Однофазный 10,0 AMPS. Стекло пассивированные мостовые выпрямители
- (KBPC15005-KBPC1510)Single Phase 15.0 AMPS. Стекло пассивированные мостовые выпрямители
- (KBPC25005-KBPC2510)Single Phase 25.0 AMPS. Стекло пассивированные мостовые выпрямители
- (KBPC35005-KBPC3510)Однофазная 35,0 AMPS. Стекло пассивированные мостовые выпрямители
- (KBPC50005-KBPC5010)Однофазная 50,0 AMPS. Стекло пассивированные мостовые выпрямители
- (KBPC25005W-KBPC2510W)Single Phase 25.0 AMPS. Стекло пассивированные мостовые выпрямители
- (KBPC35005W-KBPC3510W)Однофазная 35,0 AMPS. Стекло пассивированные мостовые выпрямители
- (KBPC50005W-KBPC5010W)Однофазная 50,0 AMPS. Стекло пассивированные мостовые выпрямители
- (BR25005-BR2510)Однофазное 25,0 AMPS. Стекло пассивированные мостовые выпрямители

www.tut.by email minsk17@tut.by тел.+375447584780

(BR25005W-BR2510W) Однофазная 35,0 AMPS. Стекло пассивированные мостовые выпрямители

(GBP15005-GBPC1510) Однофазное 15,0 AMPS. Стекло пассивированные мостовые выпрямители

(GBPC25005-GBPC2510) Однофазное 25,0 AMPS. Стекло пассивированные мостовые выпрямители

(GBPC35005-GBPC3510) Однофазная 35,0 AMPS. Стекло пассивированные мостовые выпрямители

(GBPC50005-GBPC5010) Однофазная 50,0 AMPS. Стекло пассивированные мостовые выпрямители

(GBPC15005W-GBPC1510W) Однофазное 15,0 AMPS. Стекло пассивированные мостовые выпрямители

(GBPC25005W-GBPC2510W) Однофазное 25,0 AMPS. Стекло пассивированные мостовые выпрямители

(GBPC35005W-GBPC3510W) Однофазная 35,0 AMPS. Стекло пассивированные мостовые выпрямители

(GBPC50005W-GBPC5010W) Однофазная 50,0 AMPS. Стекло пассивированные мостовые выпрямители

(SKBPC1504-SKBPC1516) Три фазы 15,0 AMPS. Стекло пассивированные мостовые выпрямители

(SKBPC25005 ~ SKBPC2516) Три фазы 25,0 AMPS. Стекло пассивированные мостовые выпрямители

(SKBPC35005 ~ SKBPC3516) Три фазы 35,0 AMPS. Стекло пассивированные мостовые выпрямители

(SKBPC5006-SKBPC5016) Три фазы 50,0 AMPS. Стекло пассивированные мостовые выпрямители

(S25VB005-S25VB100) Однофазное 25,0 AMPS. Стекло пассивированные мостовые выпрямители

(S35VB005-S35VB100) Однофазная 35,0 AMPS. Стекло пассивированные мостовые выпрямители

(S50VB005-S50VB100) Однофазный 50,0 AMPS. Стекло пассивированные мостовые выпрямители

Suntan Другие сильные мостовые выпрямители

2W005-2W10	KBU10005-KBU1010	KBJ4005-KBJ410	BR50005-BR5010
MB1M-MB10M	KBU15005-KBU1510	KBJ8005-KBJ810	BR15005W-BR1510W
KBP3005-KBP310	KBU25005-KBU2506	KBJ10005-KBJ1010	BR35005W-BR3510W
GBP2005-GBP210	KBU25008-KBU2510	KBJ15005-KBJ1506	BR50005W-BR5010W
GBP3005-GBP310	KBU35005-KBU3506	KBJ1508-KBJ1510	BR15005L-BR1510L
KBL601-KBL610	KBU3508-KBU3510	KBPC1005-KBPC110	BR25005L-BR2510L
KBU4005-KBU410	GBU20005-GBU2010	BR15005-BR1510	BR35005L-BR3510L
KBU8005-KBU810	GBU25005-GBU2510	BR35005-BR3510	BR50005L-BR5010L
DB201-DB207	KBPC15005-KBPC1510	GBJ50005-GBJ5010	D2KB05 через D2KB10
DB201S-DB207S	KBPC15005W-KBPC1510W	MT3506-MT3516	D3KB05 через D3KB10
GBL4005-GBL410	KBPC3005-KBPC310	MT5006-MT5016	D4KB05 через D4KB10

Значок мостового выпрямителя

Мостовые выпрямители меняют напряжение переменного тока на постоянное напряжение. Они используются в широком спектре электроники и чаще всего используются в устройствах с питанием от сети переменного тока, современных домашних телефонах, простых источниках питания и даже в контроллерах двигателя с высокой мощностью. Многие современные устройства пользовались преимуществами этих полупроводниковых полупроводниковых приборов, поскольку они заменили отказоустойчивые оксидные выпрямители, используемые много лет назад.

Мостовые выпрямители могут быть либо в форме «полуволны», либо «полной волне». Конденсаторы электролитического фильтра обычно добавляют для сглаживания пульсаций ректификации. Устройство также может использоваться для обеспечения того, чтобы питание постоянного тока (аккумулятора) происходило фиксированным образом, даже если аккумулятор подключен неправильно. В современных телефонах они обеспечивают надлежащую связь и электрическую изоляцию с входящими телефонными линиями. Даже если телефонные провода ошибочны, телефон все равно будет работать правильно.

W005 THRU W10

SINGLE-PHASE BRIDGE RECTIFIER

REVERSE VOLTAGE 50 to 1000 Volts FORWARD CURRENT 1.5 Amperes

FEATURES

- ◆ Rating to 1000VPRV.
- ◆ Ideal for printed circuit board.
- ◆ Low forward voltage drop, high current capability.
- ◆ Reliable low cost construction utilizing molded epoxy technique results in inexpensive product.
- ◆ The plastic material has UL flammability classification 94V-0.

Mechanical Data

- ◆ Case: Molded plastic.
- ◆ Polarity: As marked on Body.
- ◆ Weight: 0.05 ounces, 1.42grams.
- ◆ Mounting position: Any.

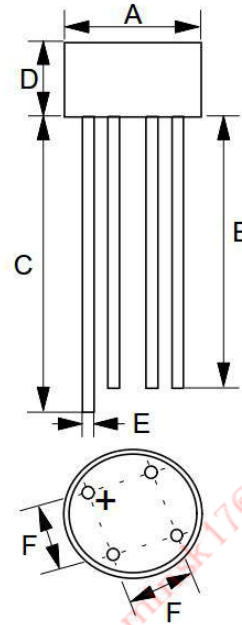

WOB		
DIM.	MIN.	MAX.
A	8.90	9.30
B	25.4	-
C	27.9	-
D	5.10	5.60
E	0.70	0.80
F	4.60	5.60

All Dimensions in millimeter

MAXIMUM RATINGS AND ELECTRICAL CHARACTERISTICS

Rating at 25°C ambient temperature unless otherwise specified.

Single phase, half wave, 60Hz, resistive or inductive load. For capacitive load, derate current by 20%

PARAMETER	SYMBOL	W005	W01	W02	W04	W06	W08	W10	UNIT
Maximum Recurrent Peak Reverse Voltage	V_{RRM}	50	100	200	400	600	800	1000	V
Maximum RMS Voltage	V_{RMS}	35	70	140	280	420	560	700	V
Maximum DC Blocking Voltage	V_{DC}	50	100	200	400	600	800	1000	V
Maximum Average Forward Rectified Current @ $T_A=25^\circ\text{C}$	$I_{(AV)}$	1.5							A
Peak Forward Surge Current 8.3ms single half sine-wave superimposed on rated load (JEDEC Method)	I_{FSM}	50							A
Maximum forward Voltage at 1.0A DC	V_F	1.0							V
Maximum DC Reverse Current at Rated DC Blocking Voltage @ $T_J=25^\circ\text{C}$ @ $T_J=125^\circ\text{C}$	I_R	50 500							μA
I^2t Rating for fusing ($t < 8.3\text{ms}$)	I^2t	10.4							A^2S
Typical Junction Capacitance per element (Note 1)	C_J	20							pF
Typical Thermal Resistance (Note 2)	$R_{\theta JA}$	36							$^\circ\text{C}/\text{W}$
Operating Temperature Range	T_J	-55 to +150							$^\circ\text{C}$
Storage Temperature Range	T_{STG}	-55 to +150							$^\circ\text{C}$

Note: 1. Measured at 1.0 MHz and applied reverse voltage of 4.0 Volts.

2. Thermal Resistance Junction to Ambient.

W005 THRU W10

SINGLE-PHASE BRIDGE RECTIFIER

REVERSE VOLTAGE 50 to 1000 Volts FORWARD CURRENT 1.5 Amperes

RATING AND CHARACTERISTIC CURVES W005 THRU W10

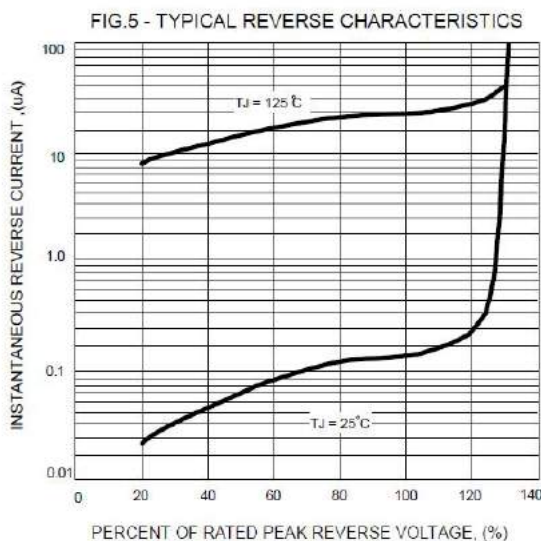
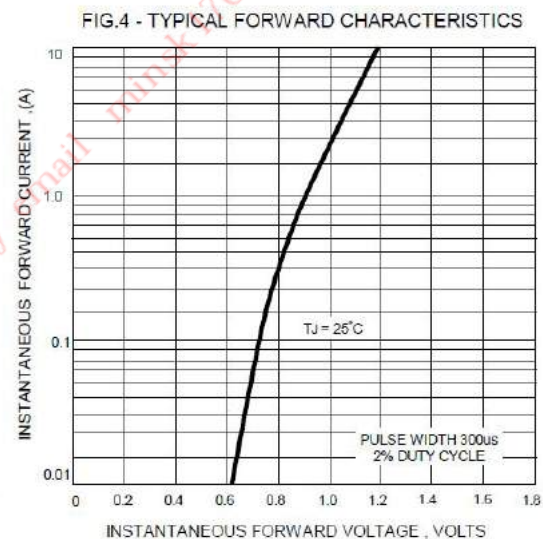
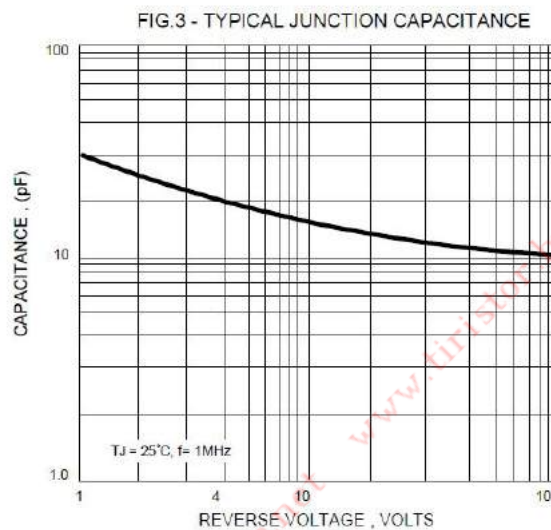
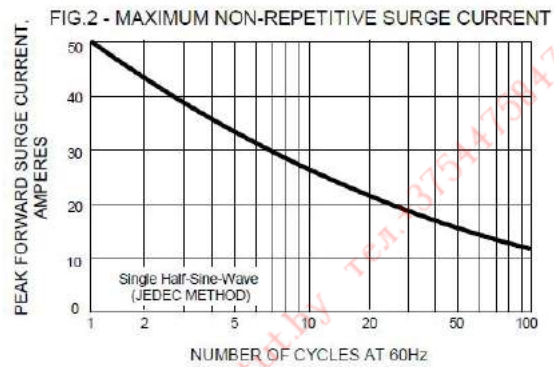
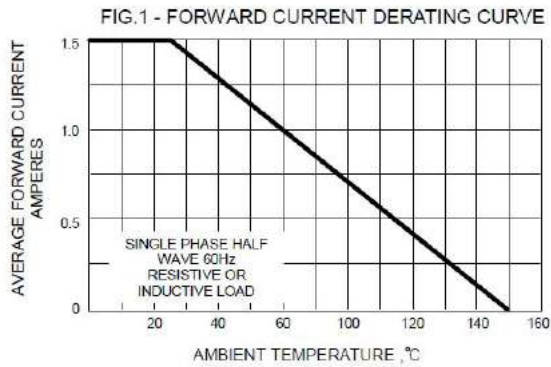

Note: Specifications are subject to change without notice. For more detail and update, please visit our website.

MB1F THRU MB10F

SURFACE MOUNT FAST SWITCHING RECTIFIER

REVERSE VOLTAGE 50 to 1000 Volts FORWARD CURRENT 1.0 Ampere

FEATURES

- ◆ Glass passivated chip junction.
- ◆ Ideal for surface mounted applications.
- ◆ Low leakage.
- ◆ High forward surge current capability.
- ◆ High temperature soldering guaranteed:
260°C/10 seconds at terminals.

Mechanical Data

- ◆ Case: Molded plastic body.
- ◆ Epoxy: UL94V-0 rate flame retardant.
- ◆ Polarity: Molded on body.
- ◆ Lead: Plated terminals solderable per MIL-STD-202E method 208C.
- ◆ Weight: 0.003 ounce, 0.1 gram.

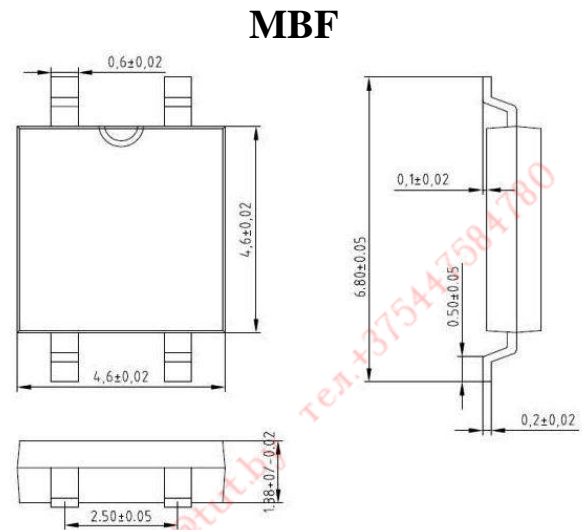

Dimensions in inches and (millimeters)

MAXIMUM RATINGS AND ELECTRICAL CHARACTERISTICS

Rating at 25°C ambient temperature unless otherwise specified.

Single phase, half wave, 60Hz, resistive or inductive load. For capacitive load, derate current by 20%

PARAMETER	SYMBOL	MB1F	MB2F	MB3F	MB4F	MB6F	MB8F	MB10F	UNIT
Maximum Recurrent Peak Reverse Voltage	V_{RRM}	50	100	200	400	600	800	1000	V
Maximum RMS Voltage	V_{RMS}	35	70	140	280	420	560	700	V
Maximum DC Blocking Voltage	V_{DC}	50	100	200	400	600	800	1000	V
Maximum Average Forward Rectified Output Current, 0.06" (1.5mm) lead length at $T_A=40^\circ\text{C}$ (Note 2)	$I_{(AV)}$	1.0							A
Peak Forward Surge Current, 8.3ms single half-sine-wave superimposed on rated load (JEDEC method)	I_{FSM}	30							A
Rating for Fusing ($t < 8.3\text{ms}$)	I^2t	10							A^2s
Maximum Instantaneous Forward Voltage drop Per Bridge element 1.0A	V_F	1.1							V
Maximum DC Reverse Current at $T_A=25^\circ\text{C}$ at Rated DC Blocking voltage $T_A=125^\circ\text{C}$	I_R	5.0							μA
		0.5							mA
Typical Junction Capacitance (Note 1)	C_J	25							pF
Typical Thermal Resistance (Note 2)	$R_{\theta JC}$	40							$^\circ\text{C}/\text{W}$
Operating and Storage Temperature Range	T_J, T_{STG}	-55 to +150							$^\circ\text{C}$

Note: 1. Measured at 1.0MHz and applied reverse voltage of 4.0 Volts.

2. Unit mounted on P.C.B. with 0.95"×1.15" copper pads.

MB1F THRU MB10F

SURFACE MOUNT FAST SWITCHING RECTIFIER

REVERSE VOLTAGE 50 to 1000 Volts FORWARD CURRENT 1.0 Ampere

RATING AND CHARACTERISTIC CURVES MB1F THRU MB10F

F1G.1-FORWARD CURRENT DERATING CURVE

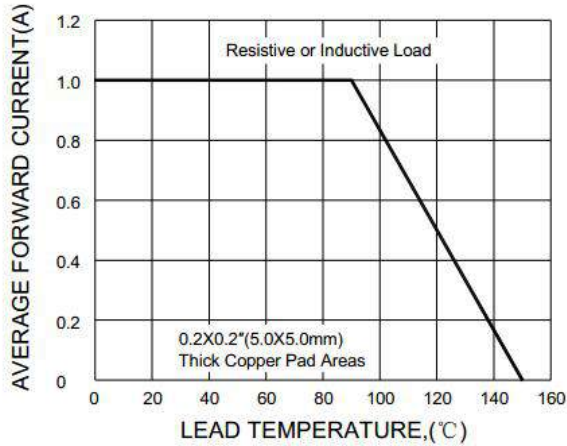

F1G.2-MAXIMUM NON-REPETITIVE PEAK FORWARD SURGE CURRENT

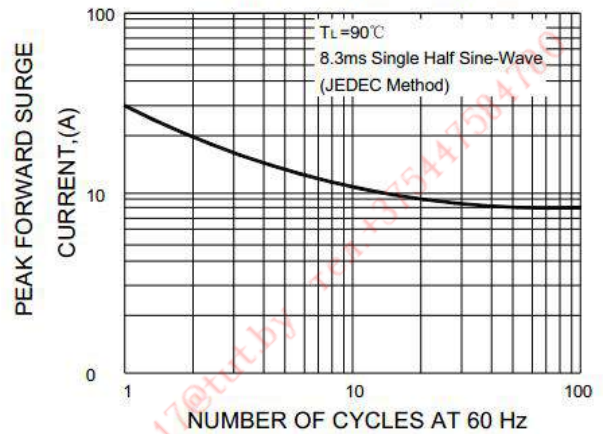

F1G.3-TYPICAL INSTANTANEOUS FORWARD CHARACTERISTICS

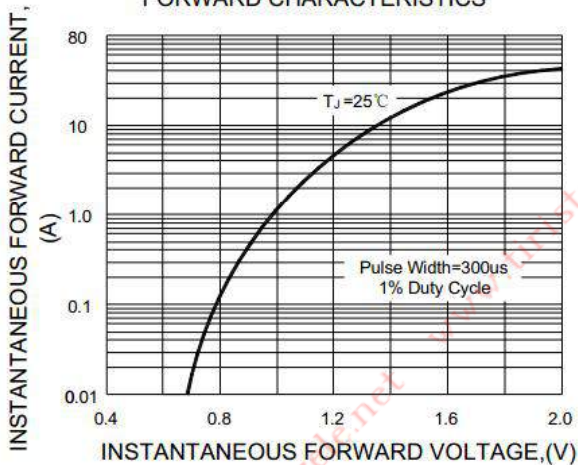

F1G.4-TYPICAL REVERSE CHARACTERISTICS

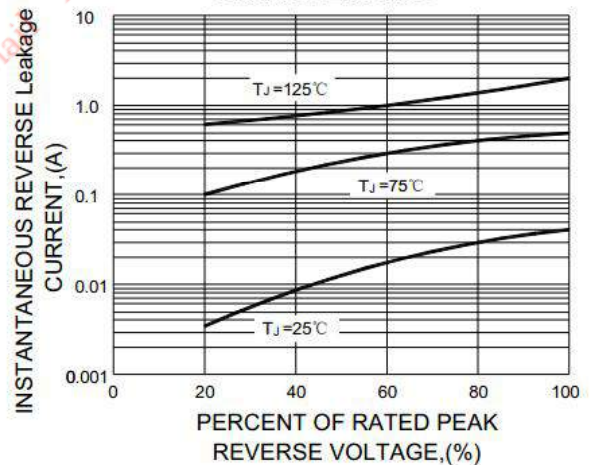

F1G.5-TYPICAL JUNCTION CAPACITANCE

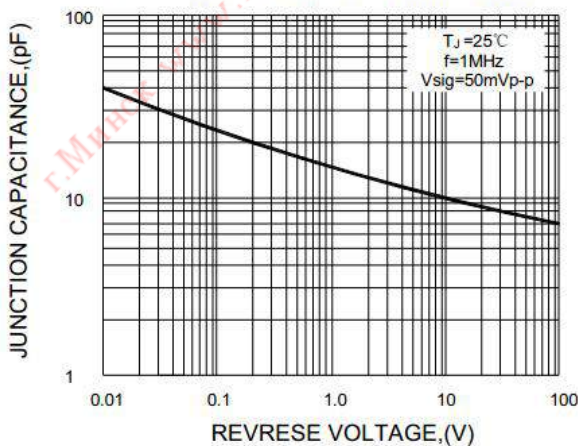

Note: Specifications are subject to change without notice. For more detail and update, please visit our website.

ABS1 THRU ABS10

SURFACE MOUNT FAST SWITCHING RECTIFIER

REVERSE VOLTAGE 50 to 1000 Volts FORWARD CURRENT 1.0 Ampere

FEATURES

- ◆ Glass passivated chip junction.
- ◆ Ideal for surface mounted applications.
- ◆ Low leakage.
- ◆ High forward surge current capability.
- ◆ High temperature soldering guaranteed:
260°C/10 seconds at terminals.

Mechanical Data

- ◆ Case: Molded plastic body.
- ◆ Epoxy: UL94V-0 rate flame retardant.
- ◆ Polarity: Molded on body.
- ◆ Lead: Plated terminals solderable per MIL-STD-202E method 208C.
- ◆ Weight: 0.003 ounce, 0.1 gram.

ABS

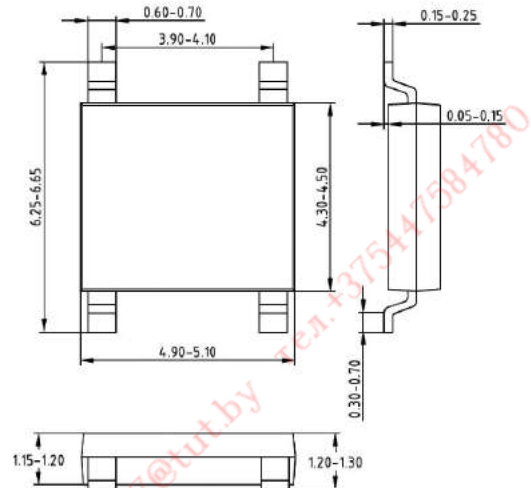

Dimensions in inches and (millimeters)

MAXIMUM RATINGS AND ELECTRICAL CHARACTERISTICS

Rating at 25°C ambient temperature unless otherwise specified.

Single phase, half wave, 60Hz, resistive or inductive load. For capacitive load, derate current by 20%

PARAMETER	SYMBOL	ABS1	ABS2	ABS3	ABS4	ABS6	ABS8	ABS10	UNIT
Maximum Recurrent Peak Reverse Voltage	V_{RRM}	50	100	200	400	600	800	1000	V
Maximum RMS Voltage	V_{RMS}	35	70	140	280	420	560	700	V
Maximum DC Blocking Voltage	V_{DC}	50	100	200	400	600	800	1000	V
Maximum Average Forward Rectified Output Current, 0.06" (1.5mm) lead length at $T_L=90^\circ\text{C}$ (Note 2)	$I_{(AV)}$	1.0							A
Peak Forward Surge Current, 8.3ms single half-sine-wave superimposed on rated load (JEDEC method)	I_{FSM}	30							A
Rating for Fusing ($t < 8.3\text{ms}$)	I^2t	10							A^2s
Maximum Instantaneous Forward Voltage drop Per Bridge element 1.0A	V_F	1.1							V
Maximum DC Reverse Current at $T_A=25^\circ\text{C}$ at Rated DC Blocking voltage $T_A=125^\circ\text{C}$	I_R	5							μA
		0.5							mA
Typical Junction Capacitance (Note 1)	C_J	25							pF
Typical Thermal Resistance (Note 2)	$R_{\theta JC}$	40							$^\circ\text{C}/\text{W}$
Operating and Storage Temperature Range	T_J, T_{STG}	-55 to +150							$^\circ\text{C}$

Note: 1. Measured at 1.0MHz and applied reverse voltage of 4.0 Volts.

2. Unit mounted on P.C.B. with 5.72mm×7.22mm copper pads.

ABS1 THRU ABS10

SURFACE MOUNT FAST SWITCHING RECTIFIER

REVERSE VOLTAGE 50 to 1000 Volts FORWARD CURRENT 1.0 Ampere

RATING AND CHARACTERISTIC CURVES ABS1 THRU ABS10

FIG.1-FORWARD CURRENT DERATING CURVE

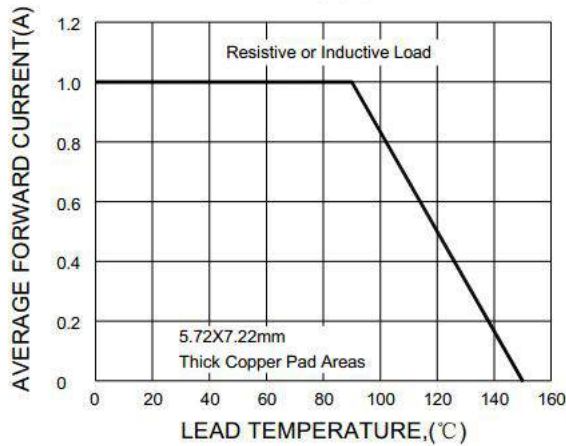

FIG.2-MAXIMUM NON-REPETITIVE PEAK FORWARD SURGE CURRENT

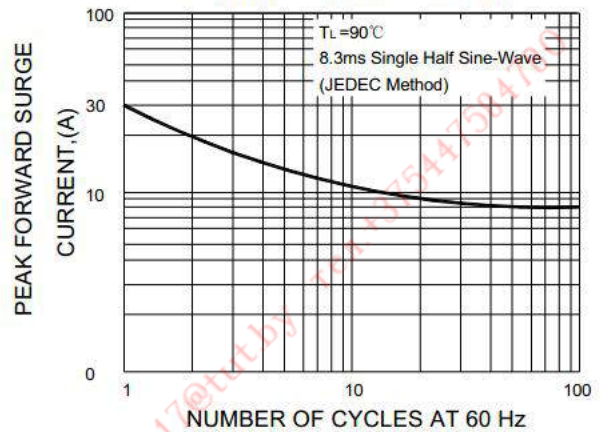

FIG.3-TYPICAL INSTANTANEOUS FORWARD CHARACTERISTICS

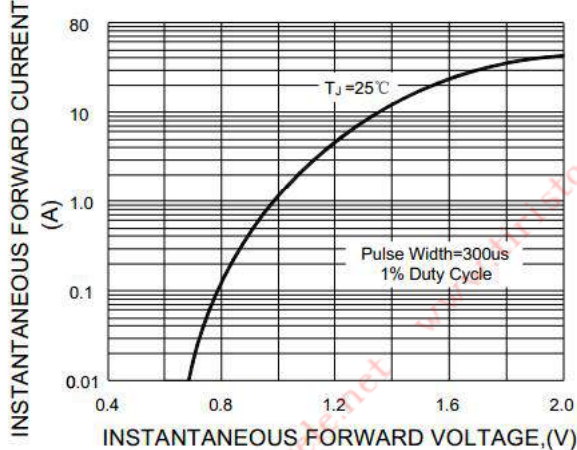

FIG.4-TYPICAL REVERSE CHARACTERISTICS

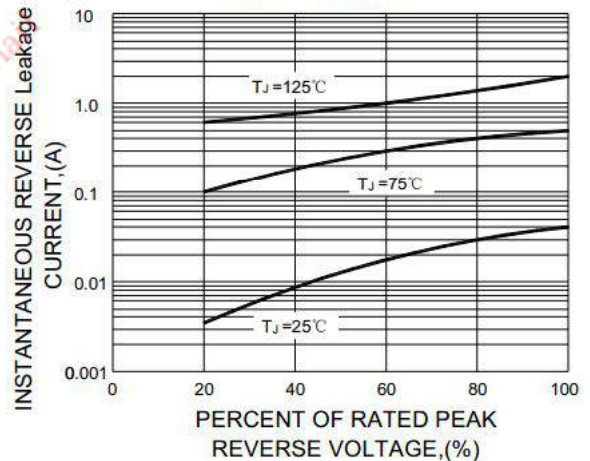

FIG.5-TYPICAL JUNCTION CAPACITANCE

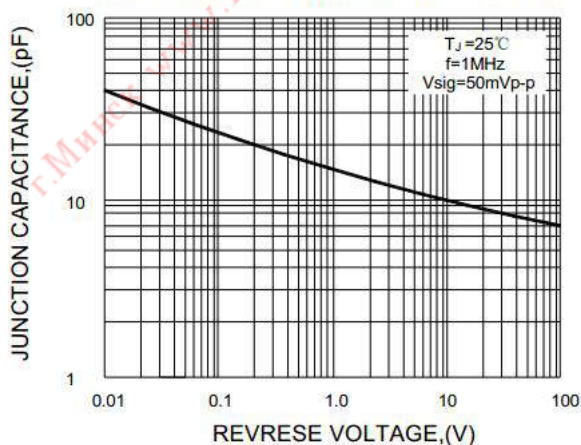
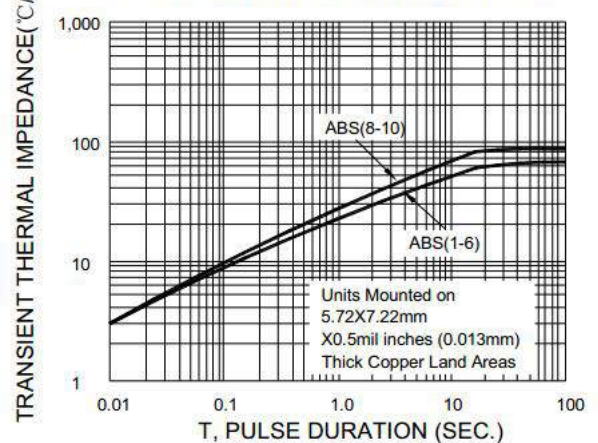

FIG.6-TRANSIENT THERMAL IMPEDANCE



Note: Specifications are subject to change without notice. For more detail and update, please visit our website.

MB1S THRU MB10S

SURFACE MOUNT GLASS PASSIVATED BRIDGE RECTIFIERS

REVERSE VOLTAGE: 100 to 1000 Volts FORWARD CURRENT: 0.8 Ampere

FEATURES

- ◆ Rating to 1000V PRV
- ◆ Ideal for printed circuit board
- ◆ Reliable low cost construction utilizing molded plastic technique results in inexpensive product
- ◆ Lead tin plated copper

Mechanical Data

- ◆ Polarity: Symbol molded on body
- ◆ Mounting position: Any

MBS

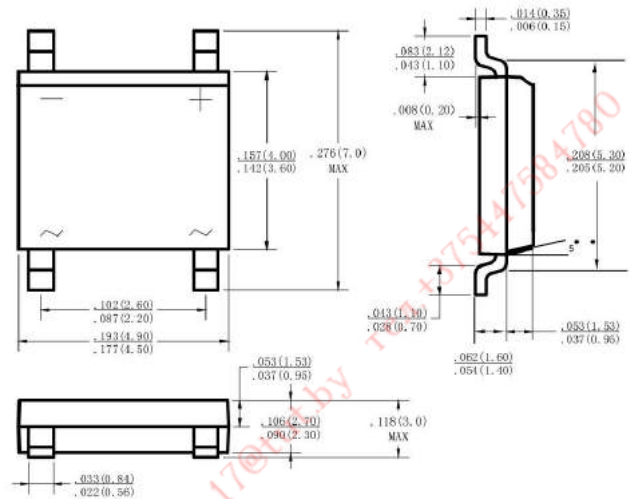

Dimensions in inches and (millimeters)

MAXIMUM RATINGS AND ELECTRICAL CHARACTERISTICS

Rating at 25°C ambient temperature unless otherwise specified.

Single phase, half wave, 60Hz, resistive or inductive load. For capacitive load, derate current by 20%

CHARACTERISTICS	SYMBOLS	MB1S	MB2S	MB4S	MB6S	MB8S	MB10S	UNITS
Maximum Repetitive Peak Reverse Voltage	V_{RRM}	100	200	400	600	800	1000	V
Maximum RMS Voltage	V_{RMS}	70	140	280	420	560	700	V
Maximum DC Blocking Voltage	V_{DC}	100	200	400	600	800	1000	V
Maximum Average Forward Rectified Current (Note 1) @ $T_A=40^\circ C$	$I_{(AV)}$	0.8						A
Peak Forward Surge Current 8.3ms Single Half Sine-Wave Super Imposed on Rated Load(JEDEC Method)	I_{FSM}	30						A
Peak Forward Voltage at 0.8A DC	V_F	1.1						V
Maximum DC Reverse Current @ $T_J=25^\circ C$ at Rated DC Blocking Voltage @ $T_J=125^\circ C$	I_R	5.0 500						μA
Typical Junction Capacitance Per Element (Note2)	C_J	15						pF
Typical Thermal Resistance (Note3)	$R_{\theta JL}$	75						$^\circ C/W$
Operating Temperature Range	T_J	-55 to +150						$^\circ C$
Storage Temperature Range	T_{STG}	-55 to +150						$^\circ C$

Note: NOTES: 1.Mounted on P.C. board. 2. Measured at 1.0MHz and applied reverse voltage of 4.0V DC. 3. Thermal resistance junction to case

MB1S THRU MB10S

SURFACE MOUNT GLASS PASSIVATED BRIDGE RECTIFIERS
 REVERSE VOLTAGE: 100 to 1000 Volts FORWARD CURRENT: 0.8 Ampere

RATING AND CHARACTERISTIC CURVES MB1S THRU MB10S

FIG.1-FORWARD CURRENT DERATING CURVE

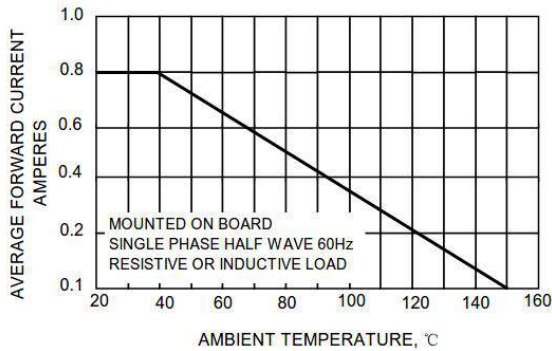

FIG.2 - MAXIMUM NON-REPETITIVE SURGE CURRENT

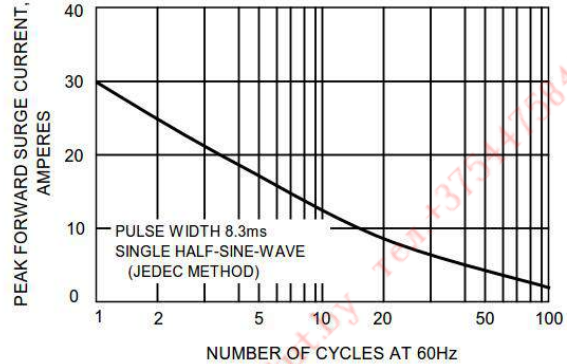

FIG.3-TYPICAL REVERSE CHARACTERISTICS

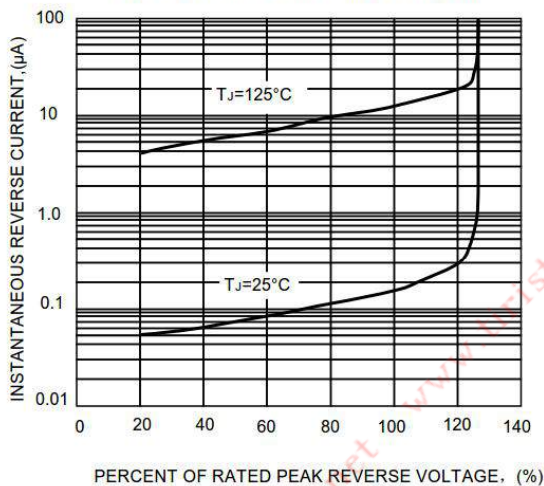

FIG.4-TYPICAL FORWARD CHARACTERISTICS

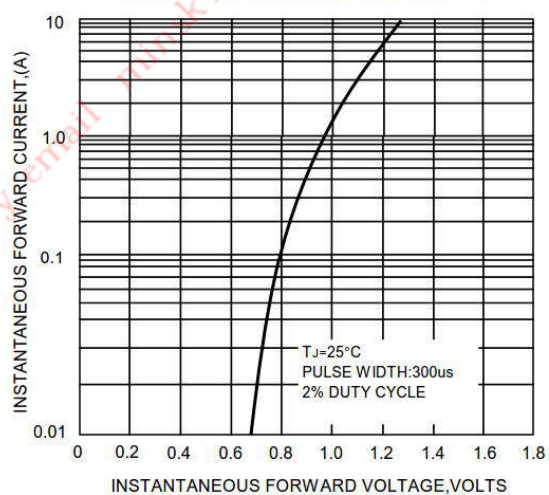
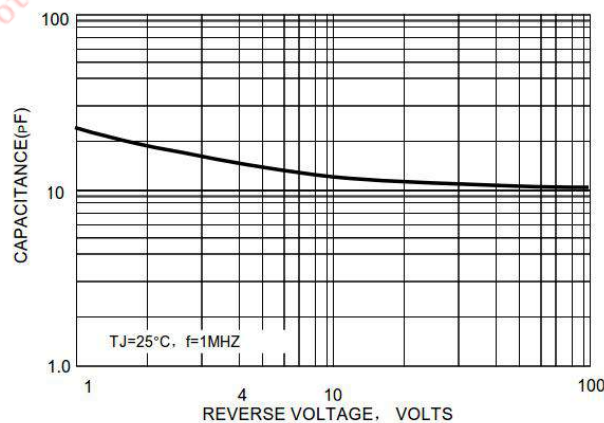

FIG.5-TYPICAL JUNCTION CAPACITANCE



Note: Specifications are subject to change without notice. For more detail and update, please visit our website.

DB101S THRU DB107S

SINGLE-PHASE GLASS PASSIVATED SILICON SURFACE MOUNT BRIDGE RECTIFIER
 REVERSE VOLTAGE 50 to 1000 Volts FORWARD CURRENT 1.0 Ampere

FEATURES

- ◆ Plastic material has Underwriters Laboratory
- ◆ Flammability Classification 94V-0
- ◆ High surge overload rating of 50 Amperes peak
- ◆ Ideal for printed circuit board
- ◆ Glass passivated chip junction

Mechanical Data

- ◆ Case: Molded plastic, DBS
- ◆ Epoxy: UL 94V-0 rate flame retardant
- ◆ Terminals: Leads solderable per MIL-STD-202, method 208 guaranteed
- ◆ Mounting position: Any
- ◆ Weight: 0.02ounce, 0.4gram

DBS

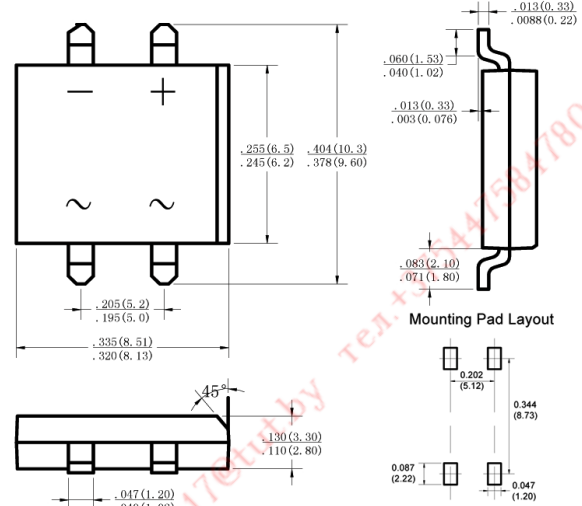

Dimensions in inches and (millimeters)

MAXIMUM RATINGS AND ELECTRICAL CHARACTERISTICS

Rating at 25°C ambient temperature unless otherwise specified.

Single phase, half wave, 60Hz, resistive or inductive load. For capacitive load, derate current by 20%

PARAMETER	SYMBOL	DB101S	DB102S	DB103S	DB104S	DB105S	DB106S	DB107S	UNIT
Maximum Recurrent Peak Reverse Voltage	V_{RRM}	50	100	200	400	600	800	1000	Volts
Maximum RMS Voltage	V_{RMS}	35	70	140	280	420	560	700	Volts
Maximum DC Blocking Voltage	V_{DC}	50	100	200	400	600	800	1000	Volts
Maximum Average Forward Rectified Current at $T_A=40^\circ\text{C}$ (Note 2)	$I_{(AV)}$	1.0							Amps
Peak Forward Surge Current 8.3ms single half sine-wave superimposed on rated load (JEDEC method)	I_{FSM}	30							Amps
Maximum Forward Voltage at 1.0A DC and 25°C	V_F	1.1							Volts
Maximum Reverse Current at Rated DC Blocking Voltage	I_R	$T_A = 25^\circ\text{C}$							uA
		$T_A = 125^\circ\text{C}$							
Typical Junction Capacitance (Note 1)	C_J	25							pF
Typical Thermal Resistance (Note 2)	$R_{\theta JA}$	40							°C/W
Typical Thermal Resistance (Note 2)	$R_{\theta JL}$	15							°C/W
Operating and Storage Temperature Range	T_J, T_{stg}	-55 to +150							°C

Note: 1- Measured at 1 MHz and applied reverse voltage of 4.0 VDC.

2- Units mounted on P.C.B. with 0.5 x 0.5" (13 x 13mm) copper pads.

DB101S THRU DB107S

SINGLE-PHASE GLASS PASSIVATED SILICON SURFACE MOUNT BRIDGE RECTIFIER
 REVERSE VOLTAGE 50 to 1000 Volts FORWARD CURRENT 1.0 Ampere

RATING AND CHARACTERISTIC CURVES DB101S THRU DB107S

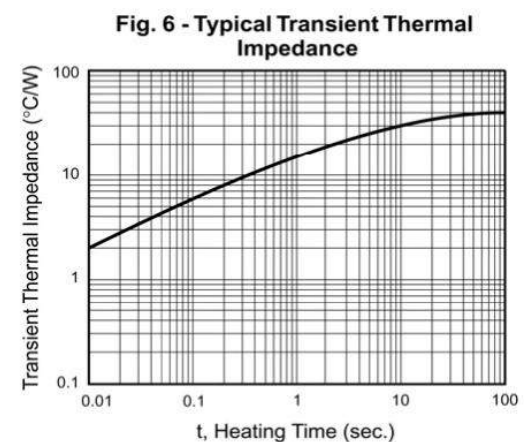
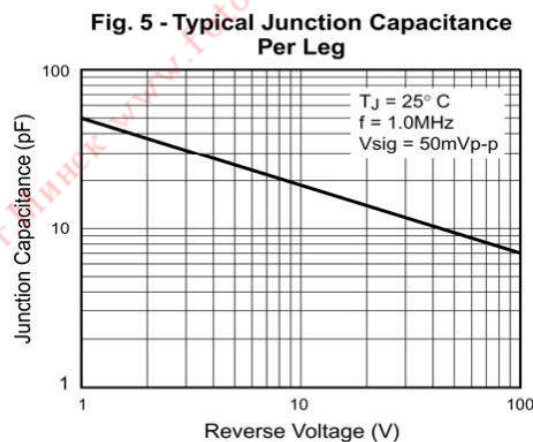
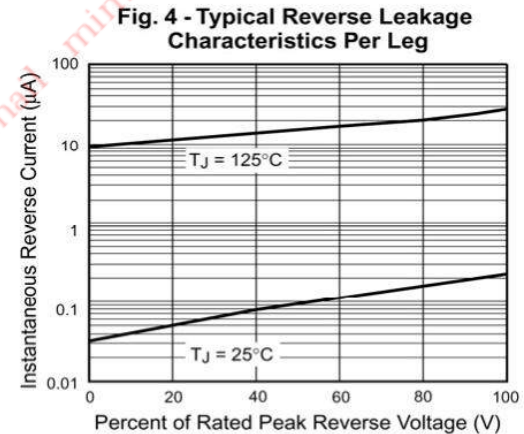
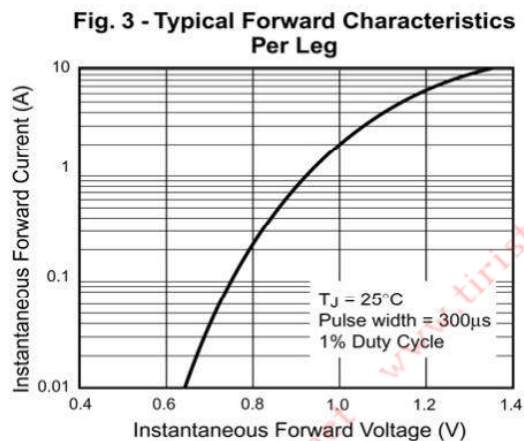
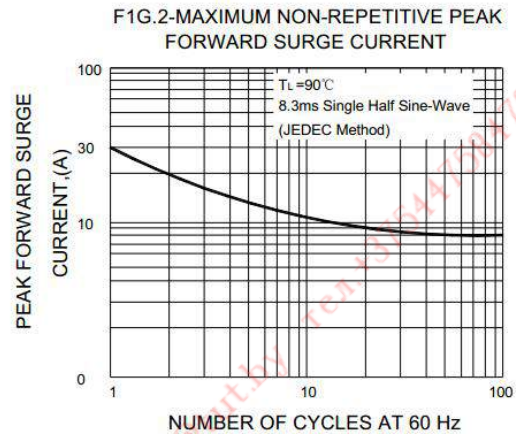
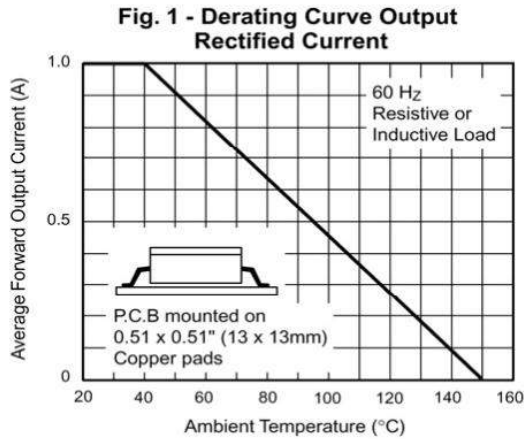

Note: Specifications are subject to change without notice. For more detail and update, please visit our website.

DB101S THRU DB107S

SINGLE-PHASE GLASS PASSIVATED SILICON SURFACE MOUNT BRIDGE RECTIFIER
 REVERSE VOLTAGE 50 to 1000 Volts FORWARD CURRENT 1.0 Ampere

FEATURES

- ◆ Plastic material has Underwriters Laboratory
- ◆ Flammability Classification 94V-0
- ◆ High surge overload rating of 50 Amperes peak
- ◆ Ideal for printed circuit board
- ◆ Glass passivated chip junction

Mechanical Data

- ◆ Case: Molded plastic, DBS
- ◆ Epoxy: UL 94V-0 rate flame retardant
- ◆ Terminals: Leads solderable per MIL-STD-202, method 208 guaranteed
- ◆ Mounting position: Any
- ◆ Weight: 0.02ounce, 0.4gram

DBS

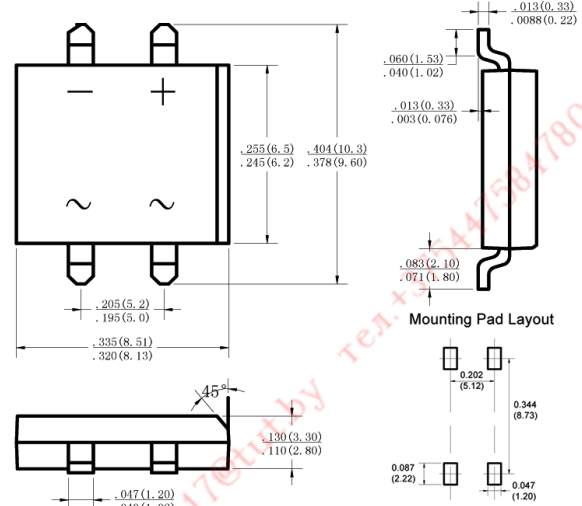

Dimensions in inches and (millimeters)

MAXIMUM RATINGS AND ELECTRICAL CHARACTERISTICS

Rating at 25°C ambient temperature unless otherwise specified.

Single phase, half wave, 60Hz, resistive or inductive load. For capacitive load, derate current by 20%

PARAMETER	SYMBOL	DB101S	DB102S	DB103S	DB104S	DB105S	DB106S	DB107S	UNIT
Maximum Recurrent Peak Reverse Voltage	V_{RRM}	50	100	200	400	600	800	1000	Volts
Maximum RMS Voltage	V_{RMS}	35	70	140	280	420	560	700	Volts
Maximum DC Blocking Voltage	V_{DC}	50	100	200	400	600	800	1000	Volts
Maximum Average Forward Rectified Current at $T_A=40^\circ\text{C}$ (Note 2)	$I_{(AV)}$	1.0							Amps
Peak Forward Surge Current 8.3ms single half sine-wave superimposed on rated load (JEDEC method)	I_{FSM}	30							Amps
Maximum Forward Voltage at 1.0A DC and 25°C	V_F	1.1							Volts
Maximum Reverse Current at Rated DC Blocking Voltage	I_R	$T_A = 25^\circ\text{C}$							uA
		$T_A = 125^\circ\text{C}$							
Typical Junction Capacitance (Note 1)	C_J	25							pF
Typical Thermal Resistance (Note 2)	$R_{\theta JA}$	40							°C/W
Typical Thermal Resistance (Note 2)	$R_{\theta JL}$	15							°C/W
Operating and Storage Temperature Range	T_J, T_{stg}	-55 to +150							°C

Note: 1- Measured at 1 MHz and applied reverse voltage of 4.0 VDC.

2- Units mounted on P.C.B. with 0.5 x 0.5" (13 x 13mm) copper pads.

DB101S THRU DB107S

SINGLE-PHASE GLASS PASSIVATED SILICON SURFACE MOUNT BRIDGE RECTIFIER
 REVERSE VOLTAGE 50 to 1000 Volts FORWARD CURRENT 1.0 Ampere

RATING AND CHARACTERISTIC CURVES DB101S THRU DB107S

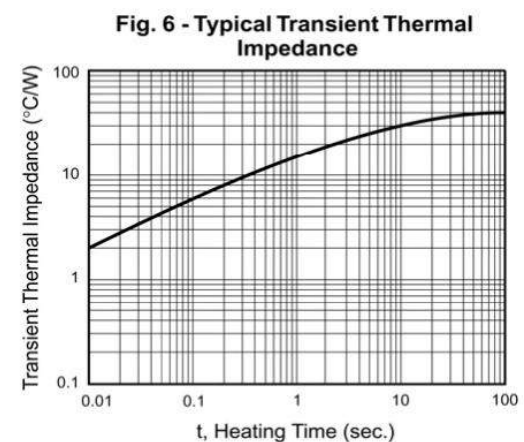
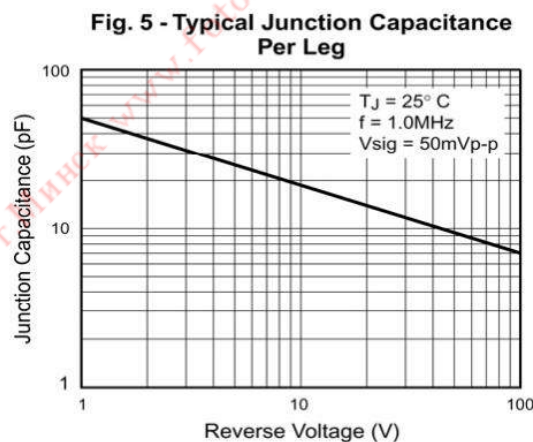
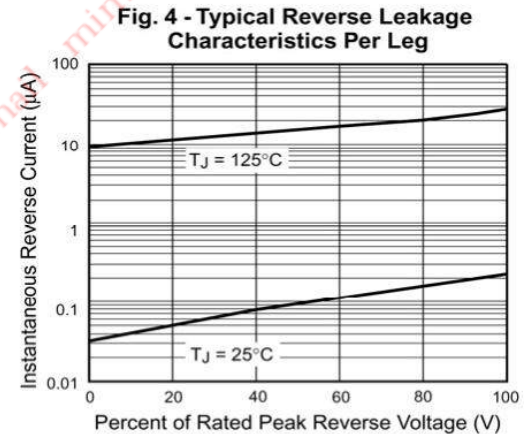
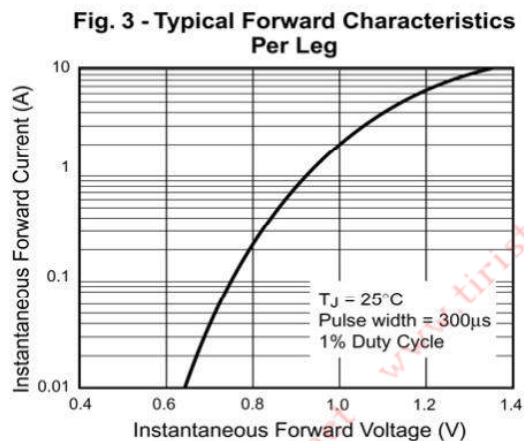
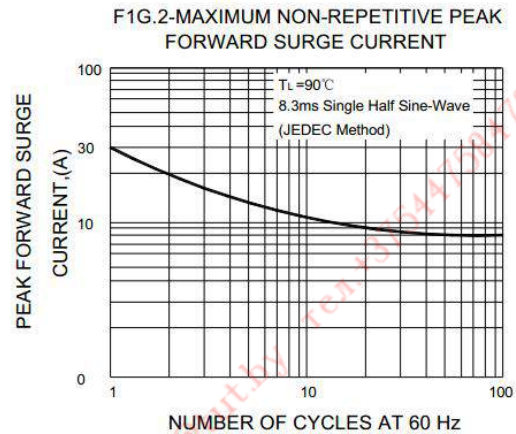
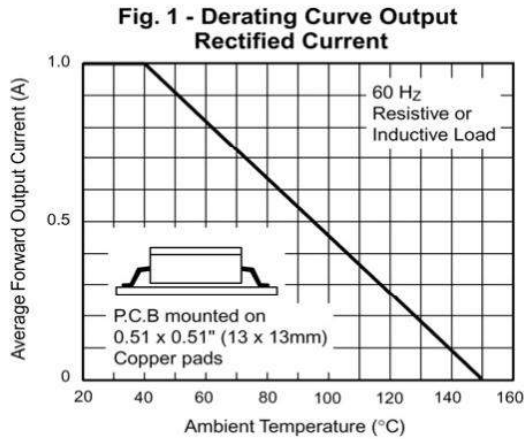

Note: Specifications are subject to change without notice. For more detail and update, please visit our website.

DB151 THRU DB157

SINGLE-PHASE GLASS PASSIVATED SILICON BRIDGE RECTIFIER
 REVERSE VOLTAGE 50 to 1000 Volts FORWARD CURRENT 1.5 Ampere

FEATURES

- ◆ Plastic material has Underwriters Laboratory Flammability Classification 94V-0.
- ◆ High surge overload rating of 50 Amperes peak.
- ◆ Ideal for printed circuit board.
- ◆ Glass passivated chip junction.

Mechanical Data

- ◆ Case: Molded plastic, DB.
- ◆ Epoxy: UL 94V-0 rate flame retardant.
- ◆ Terminals: Leads solderable per MIL-STD-2, method 208 guaranteed.
- ◆ Mounting position: Any.
- ◆ Weight: 0.02ounce, 0.4gram.

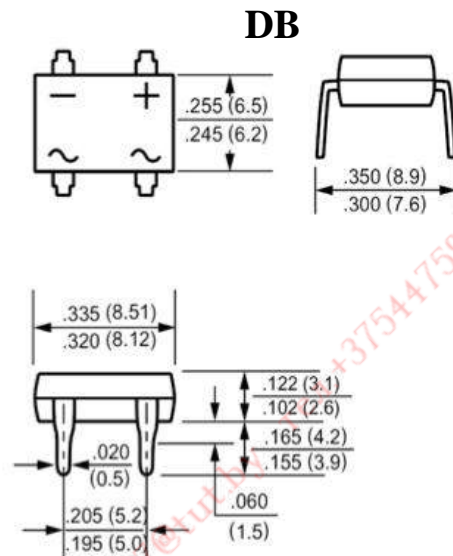

Dimensions in inches and (millimeters)

MAXIMUM RATINGS AND ELECTRICAL CHARACTERISTICS

Rating at 25°C ambient temperature unless otherwise specified.

Single phase, half wave, 60Hz, resistive or inductive load. For capacitive load, derate current by 20%

PARAMETER	SYMBOL	DB151	DB152	DB153	DB154	DB155	DB156	DB157	UNIT
Maximum Recurrent Peak Reverse Voltage	V_{RRM}	50	100	200	400	600	800	1000	V
Maximum RMS Voltage	V_{RMS}	35	70	140	280	420	560	700	V
Maximum DC Blocking Voltage	V_{DC}	100	100	200	400	600	800	1000	V
Maximum Average Forward Rectified Current at $T_A=40^\circ\text{C}$	$I_{(AV)}$	1.5							A
Peak Forward Surge Current, 8.3ms single half-sine-wave superimposed on rated load (JEDEC method)	I_{FSM}	50							A
Maximum forward Voltage at 1.0A DC and 25°C	V_F	1.1							V
Maximum DC Reverse Current at $T_A=25^\circ\text{C}$ at Rated DC Blocking voltage $T_A=125^\circ\text{C}$	I_R	5.0 500							μA
Typical Junction Capacitance (Note 1)	C_J	25							pF
Typical Thermal Resistance (Note 2)	$R_{\theta JC}$	40							$^\circ\text{C/W}$
Typical Thermal Resistance (Note 2)	$R_{\theta JL}$	15							$^\circ\text{C/W}$
Operating and Storage Temperature Range	T_J, T_{STG}	-55 to +150							$^\circ\text{C}$

Note: 1. Measured at 1.0MHz and applied reversed voltage of 4.0 VDC.

2. Thermal resistance from junction to ambient and from junction to lead mounted on P.C.B. with 0.5 x 0.5" (13 x 13mm) copper pads.

DB151 THRU DB157

SINGLE-PHASE GLASS PASSIVATED SILICON SURFACE MOUNT BRIDGE RECTIFIER
 REVERSE VOLTAGE 50 to 1000 Volts FORWARD CURRENT 1.5 Ampere

RATING AND CHARACTERISTIC CURVES DB151 THRU DB157

Fig. 1 - Derating Curve Output Rectified Current

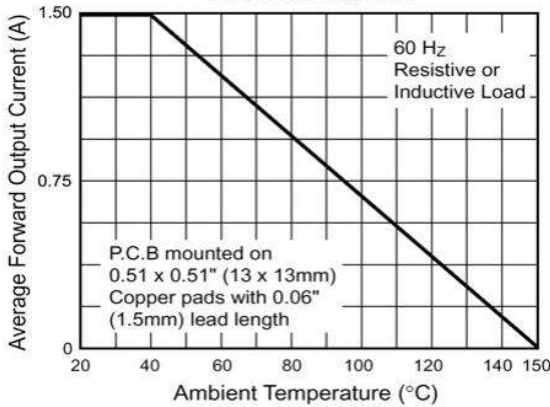

Fig. 2 - Maximum Non-Repetitive Peak Forward Surge Current Per Leg

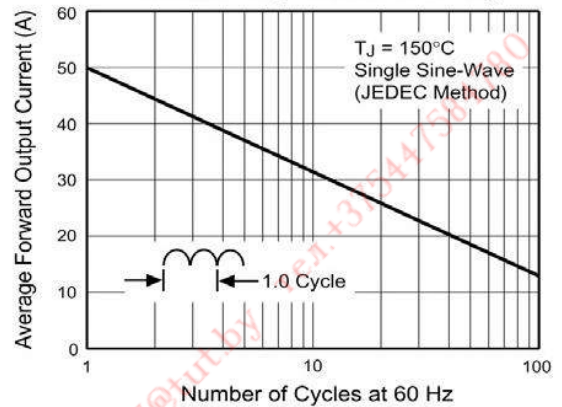

Fig. 3 - Typical Forward Characteristics Per Leg

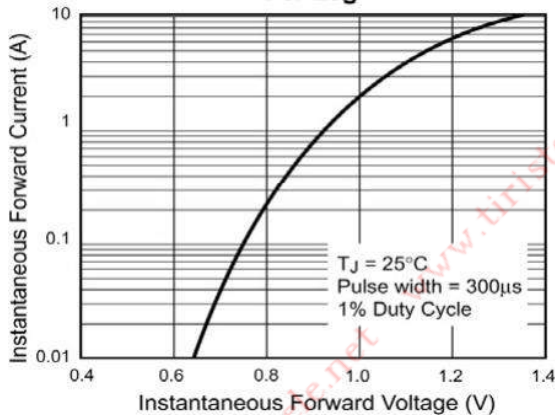

Fig. 4 - Typical Reverse Leakage Characteristics Per Leg

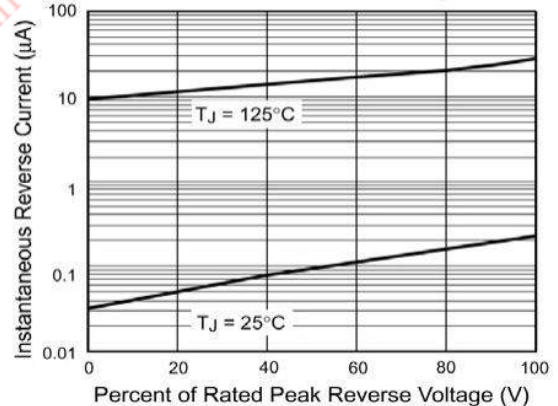

Fig. 5 - Typical Junction Capacitance Per Leg

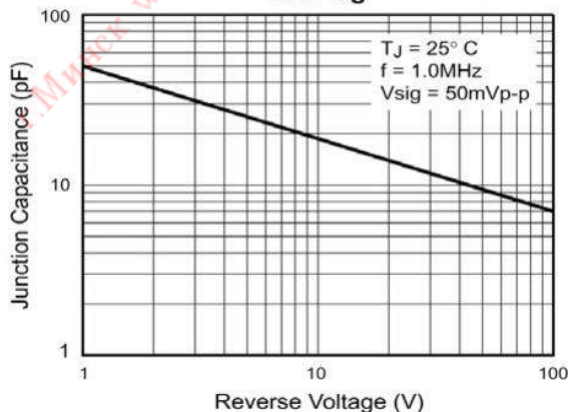
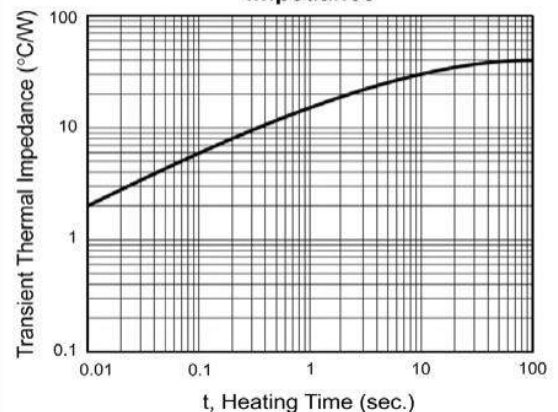

Fig. 6 - Typical Transient Thermal Impedance



Note: Specifications are subject to change without notice. For more detail and update, please visit our website.

DB151S THRU DB157S

SINGLE-PHASE GLASS PASSIVATED SILICON SURFACE MOUNT BRIDGE RECTIFIER
 REVERSE VOLTAGE 50 to 1000 Volts FORWARD CURRENT 1.5 Ampere

FEATURES

- ◆ Glass passivated chip junction.
- ◆ High surge overload rating of 50 Amperes peak.
- ◆ Ideal for printed circuit board.
- ◆ High temperature soldering guaranteed: 260°C for 10 seconds.

Mechanical Data

- ◆ Case: Molded plastic, DB-S.
- ◆ Epoxy: UL 94V-O rate flame retardant.
- ◆ Terminals: Leads solderable per MIL-STD-202, method 208 guaranteed.
- ◆ Mounting position: Any.
- ◆ Weight: 0.02ounce, 0.4gram.

DB-S

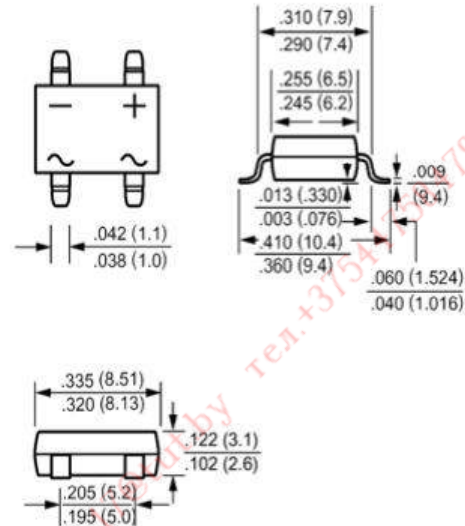

Dimensions in inches and (millimeters)

MAXIMUM RATINGS AND ELECTRICAL CHARACTERISTICS

Rating at 25°C ambient temperature unless otherwise specified.

Single phase, half wave, 60Hz, resistive or inductive load. For capacitive load, derate current by 20%

PARAMETER	SYMBOL	DB151S	DB152S	DB153S	DB154S	DB155S	DB156S	DB157S	UNIT
Maximum Recurrent Peak Reverse Voltage	V_{RRM}	50	100	200	400	600	800	1000	V
Maximum RMS Voltage	V_{RMS}	35	70	140	280	420	560	700	V
Maximum DC Blocking Voltage	V_{DC}	100	100	200	400	600	800	1000	V
Maximum Average Forward Rectified Current at $T_A=40^\circ\text{C}$ (Note 2)	$I_{(AV)}$	1.5							A
Peak Forward Surge Current, 8.3ms single half-sine-wave superimposed on rated load (JEDEC method)	I_{FSM}	50							A
Maximum forward Voltage at 1.5A DC and 25°C	V_F	1.1							V
Maximum DC Reverse Current at $T_A=25^\circ\text{C}$ at Rated DC Blocking voltage $T_A=125^\circ\text{C}$	I_R	5.0 500							μA
Typical Junction Capacitance (Note 1)	C_J	25							pF
Typical Thermal Resistance (Note 2)	$R_{\theta JC}$	40							$^\circ\text{C}/\text{W}$
Typical Thermal Resistance (Note 2)	$R_{\theta JL}$	15							$^\circ\text{C}/\text{W}$
Operating and Storage Temperature Range	T_J, T_{STG}	-55 to +150							$^\circ\text{C}$

Note: 1. Measured at 1.0MHz and applied reversed voltage of 4.0 VDC.

2. Units mounted on P.C.B. with 0.5 x 0.5" (13 x 13mm) copper pads.

DB151S THRU DB157S

SINGLE-PHASE GLASS PASSIVATED SILICON SURFACE MOUNT BRIDGE RECTIFIER
 REVERSE VOLTAGE 50 to 1000 Volts FORWARD CURRENT 1.5 Ampere

RATING AND CHARACTERISTIC CURVES DB151S THRU DB157S

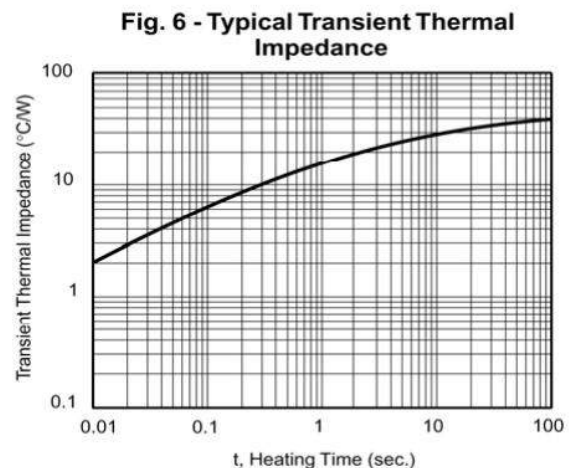
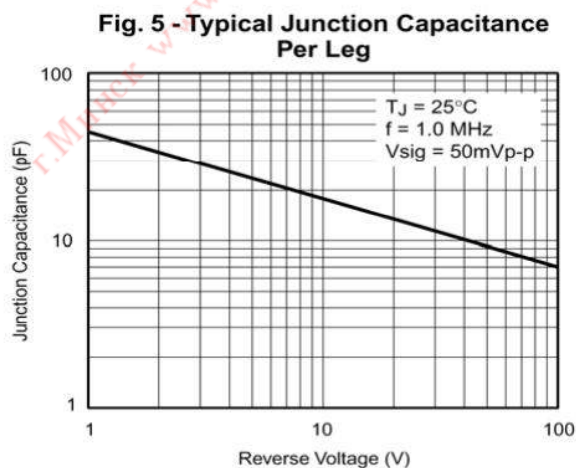
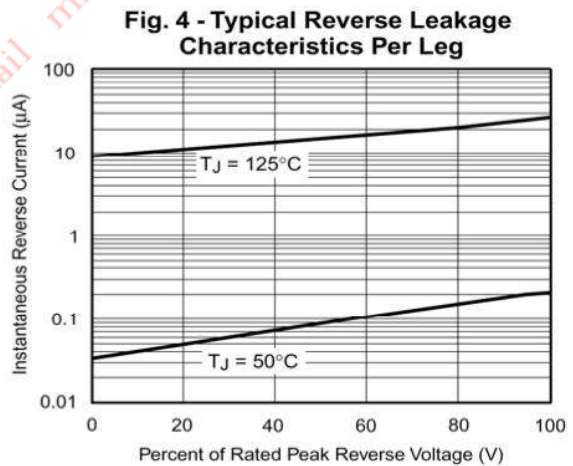
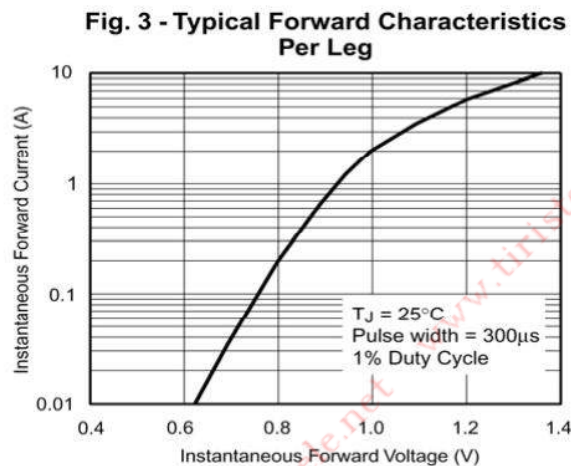
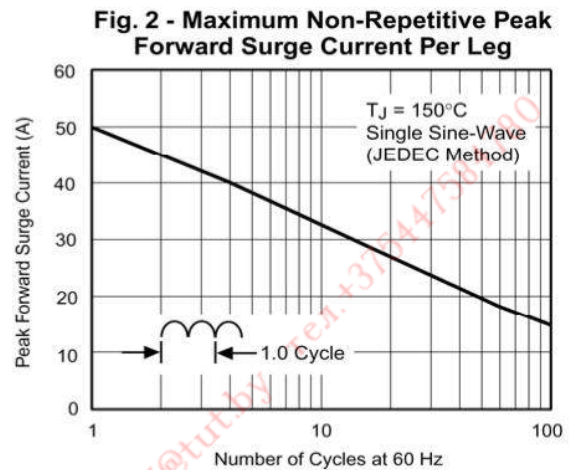
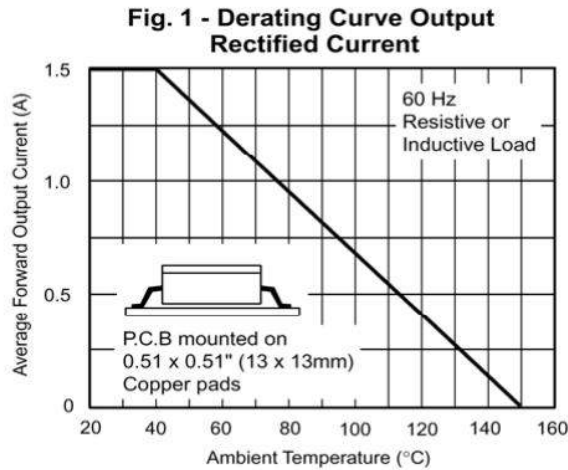

Note: Specifications are subject to change without notice. For more detail and update, please visit our website.

RS201 THRU RS207

Single Phase 2.0 AMPS. Glass Passivated Bridge Rectifiers

Voltage Range 50 to 1000 Volts

Current 2.0 Amperes

FEATURES

- ◆ Ideal for printed circuit board
- ◆ Reliable low cost construction technique results in inexpensive product
- ◆ High temperature soldering guaranteed:
260°C / 10 seconds / 0.375" (9.5mm)
lead length at 5 lbs., (2.3 kg) tension
- ◆ UL Recognized File number: E347215

Mechanical Data

- ◆ Case: Molded plastic
- ◆ Lead: solder plated
- ◆ Polarity: As marked

RS2

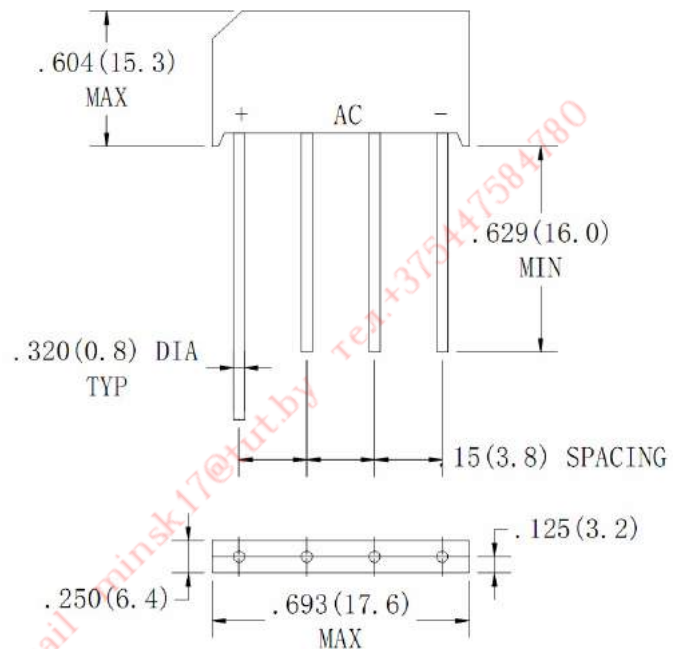

Dimensions in inches and (millimeters)

MAXIMUM RATINGS AND ELECTRICAL CHARACTERISTICS

Rating at 25°C ambient temperature unless otherwise specified.

Single phase, half wave, 60Hz, resistive or inductive load. For capacitive load, derate current by 20%

Type Number		RS201	RS202	RS203	RS204	RS205	RS206	RS207	UNITS
Maximum Repetitive Peak Reverse Voltage	V_{RRM}	50	100	200	400	600	800	1000	V
Maximum RMS Voltage	V_{RMS}	35	70	140	280	420	560	700	V
Maximum DC blocking Voltage	V_{DC}	50	100	200	400	600	800	1000	V
Maximum Average Forward Rectified Current @ $T_A = 40^\circ\text{C}$	$I(AV)$	2.0							A
Peak Forward Surge Current, 8.3 ms Single Half Sine-wave Superimposed on Rated Load (JEDEC method)	I_{FSM}	50							A
Maximum Instantaneous Forward Voltage @2.0A	V_F	1.1							V
Maximum DC Reverse Current @ $T_A=25^\circ\text{C}$	I_R	10							μA
Rated DC Blocking voltage per leg $T_A = 125^\circ\text{C}$		500							
Typical Thermal Resistance (Note)	$R\theta_{JA}$	28							$^\circ\text{C/W}$
Operating Temperature Range	T_J	-55 to +125							$^\circ\text{C}$
Storage Temperature Range	T_{STG}	-55 to +150							$^\circ\text{C}$

Note: Unit Mounted on P.C.B. with 0.47×0.47"(12×12mm) Copper Pads, 0.375"(9.5mm) Lesd Length

RS201 THRU RS207

Single Phase 2.0 AMPS. Glass Passivated Bridge Rectifiers

Voltage Range 50 to 1000 Volts

Current 2.0 Amperes

RATING AND CHARACTERISTIC CURVES RS201 THRU RS207

FIG.1-MAXIMUM NONO-REPETITIVE FORWARD SURGE CURRENT PER BRIDGE ELEMNT

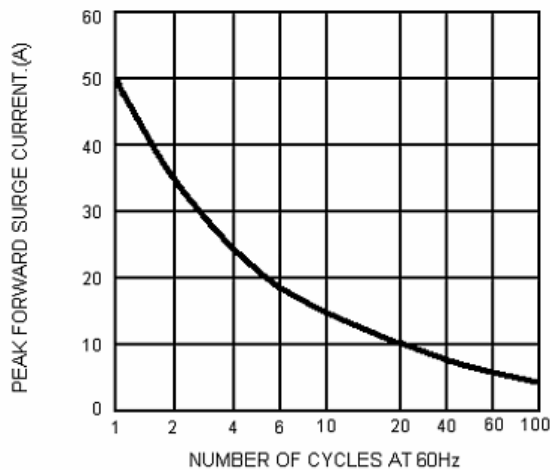

FIG.2-MAXIMUM FORWARD CURRENT DERATING CURVE

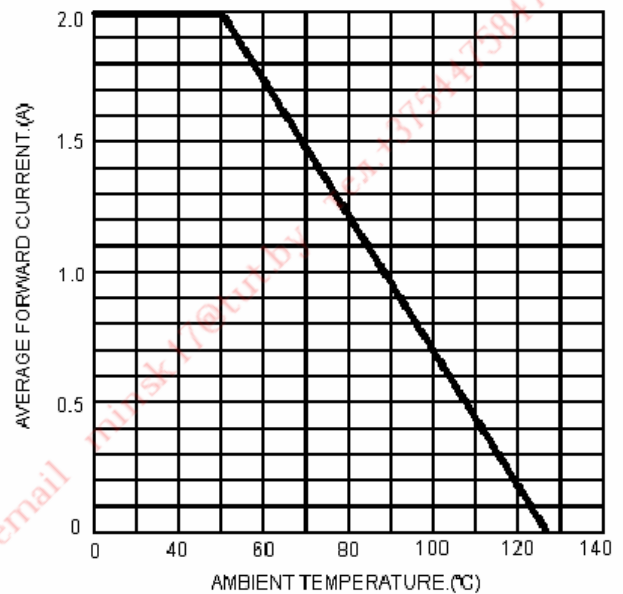

FIG.3-TYPICAL INSTANTANEOUS FORWARD CHARACTERISTICS PER BRIDGE ELEMENT

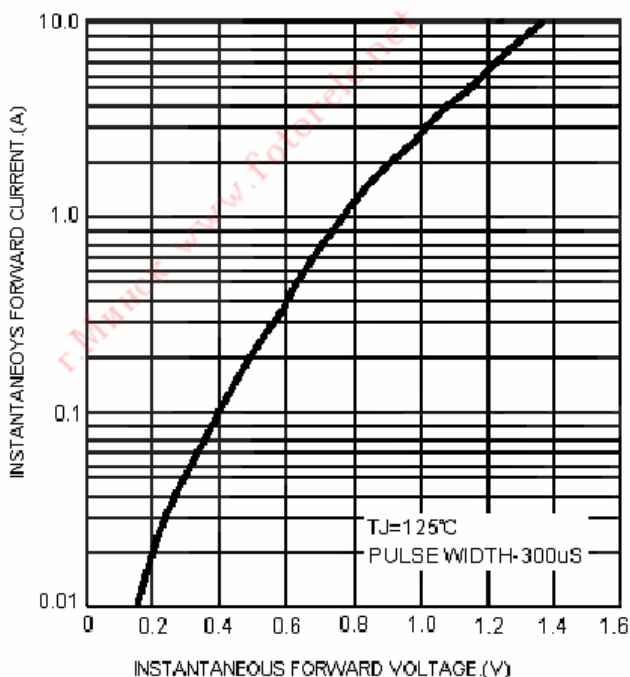
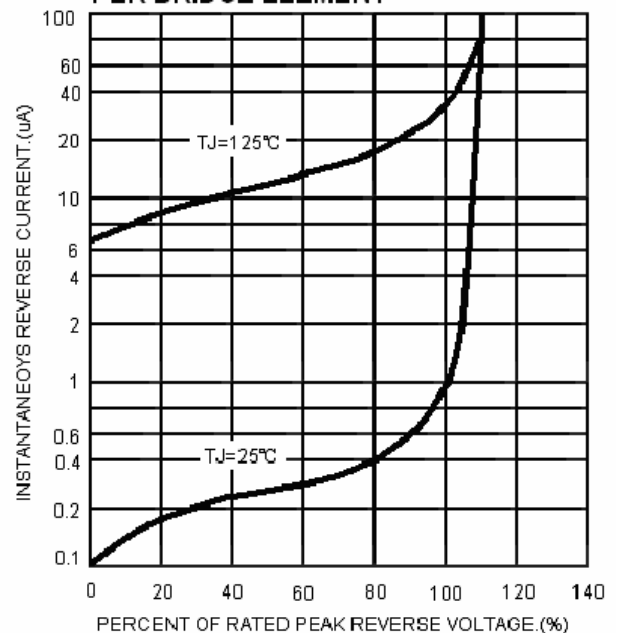

FIG.4-TYPICAL REVERSE CHARACTERISTICS PER BRIDGE ELEMENT



Note: Specification are subject to change without notice. For more detail and update, please visit our website.

KBP2005 THRU KBP210

SINGLE-PHASE BRIDGE RECTIFIER

REVERSE VOLTAGE 50 to 1000 Volts FORWARD CURRENT 2.0 Ampere

FEATURES

- ◆ High forward surge current capability.
- ◆ Ideal for printed circuit board.
- ◆ High temperature soldering guaranteed:
260°C/10 second, 0.375" (9.5mm) lead length
at 5 lbs. (2.3kg) tension.

Mechanical Data

- ◆ Case: Transfer molded plastic.
- ◆ Terminal: Lead solderable per MIL - STD - 202E
method 208°C.
- ◆ Polarity: Polarity symbols marked on case
- ◆ Mounting position: Any.
- ◆ Weight: 0.069 ounce, 1.95 gram.

KBP

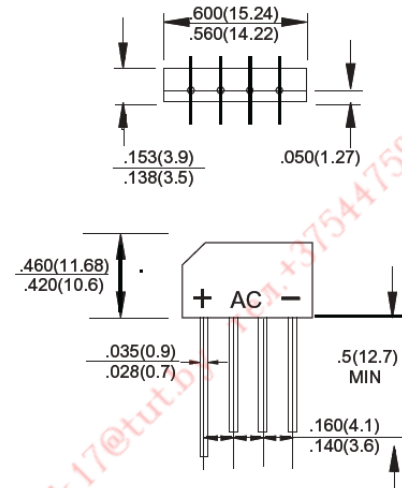

Dimensions in inches and (millimeters)

MAXIMUM RATINGS AND ELECTRICAL CHARACTERISTICS

Rating at 25°C ambient temperature unless otherwise specified.

Single phase, half wave, 60Hz, resistive or inductive load. For capacitive load, derate current by 20%

PARAMETER	SYMBOL	KBP2005	KBP201	KBP202	KBP204	KBP206	KBP208	KBP210	UNIT	
Maximum Repetitive Peak Reverse Voltage	V_{RRM}	50	100	200	400	600	800	1000	Volts	
Maximum RMS Voltage	V_{RMS}	35	70	140	280	420	560	700	Volts	
Maximum DC Blocking Voltage	V_{DC}	50	100	200	400	600	800	1000	Volts	
Maximum Average Forward Rectified Output Current, at $T_A=50^\circ\text{C}$ (Note 2)	$I_{(AV)}$	2.0							Amps	
Peak Forward Surge Current 8.3ms single half sine-wave superimposed on rated load (JEDE method)	I_{FSM}	50							Amps	
Rating for Fusing ($t < 8.3\text{ms}$)	I^2t	10							A^2s	
Maximum Instantaneous Forward Voltage Drop per bridge element at 2.0A	V_F	1.1							Volts	
Maximum DC Reverse Current at rated DC blocking voltage per element	I_R	$T_A = 25^\circ\text{C}$	5							μA
		$T_A = 100^\circ\text{C}$	0.5							mA
Typical Junction Capacitance (Note 1)	C_j	20							pF	
Typical Thermal Resistance (Note 2)	$R_{\theta JA}$	28							$^\circ\text{C}/\text{W}$	
Operating Temperature Range	T_j	-65 to +150							$^\circ\text{C}$	
Storage Temperature Range	T_{STG}	-65 to +150								

Note: 1. Measured at 1 MHz and applied reverse voltage of 4 V.

2. Thermal resistance from junction to ambient and from junction to lead mounted on P.C.B with 0.5 X 0.5" (13 X 13 mm) copper pads.

KBP2005 THRU KBP210

SINGLE-PHASE BRIDGE RECTIFIER

REVERSE VOLTAGE 50 to 1000 Volts FORWARD CURRENT 2.0 Ampere

RATING AND CHARACTERISTIC CURVES KBP2005 THRU KBP210

FIG.1-DERATING CURVE FOR
OUTPUT RECTIFIED CURRENT

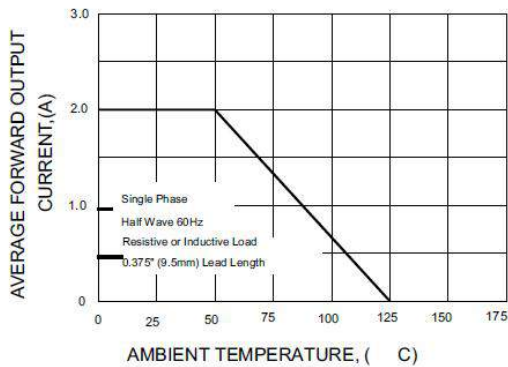

FIG.2-MAXIMUM NON-REPETITIVE PEAK
FORWARD SURGE CURRENT PER ELEMENT

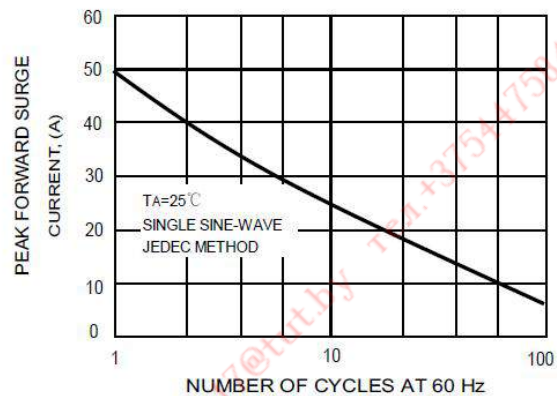

FIG.3-TYPICAL FORWARD CHARACTERISTICS
PER BRIDGE ELEMENT

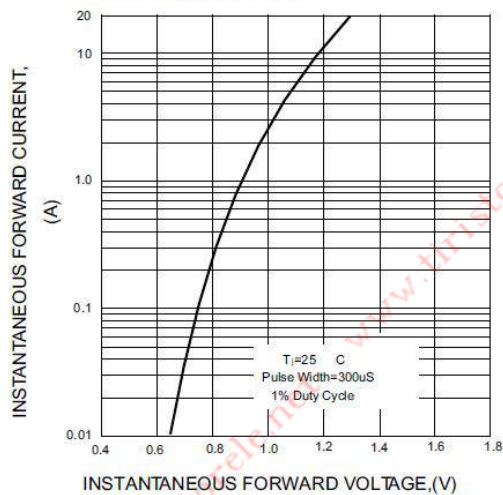

FIG.4-TYPICAL REVERSE CHARACTERISTICS
PER BRIDGE ELEMENT

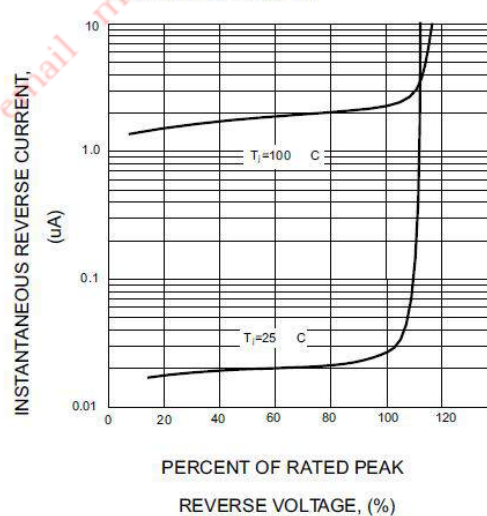
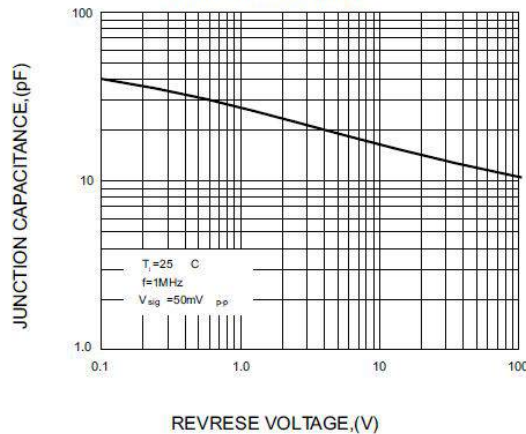

FIG.5-TYPICAL JUNCTION CAPACITANCE
PER BRIDGE ELEMENT



Note: Specifications are subject to change without notice. For more detail and update, please visit our website.

KBL4005 THRU KBL410**SINGLE-PHASE BRIDGE RECTIFIER****REVERSE VOLTAGE 50 to 1000 Volts FORWARD CURRENT 4.0 Ampere****FEATURES**

- ◆ High forward surge current capability.
- ◆ Ideal for printed circuit board.
- ◆ High temperature soldering guaranteed:
260°C/10 second, 0.375" (9.5mm) lead length
at 5 lbs. (2.3kg) tension.
- ◆ Electrically isolated base-1500 Volts.

Mechanical Data

- ◆ Case: Transfer molded plastic.
- ◆ Terminal: Lead solderable per MIL - STD - 202E
method 208°C.
- ◆ Mounting position: Any.
- ◆ Weight: 0.22 ounce, 6.21 gram.

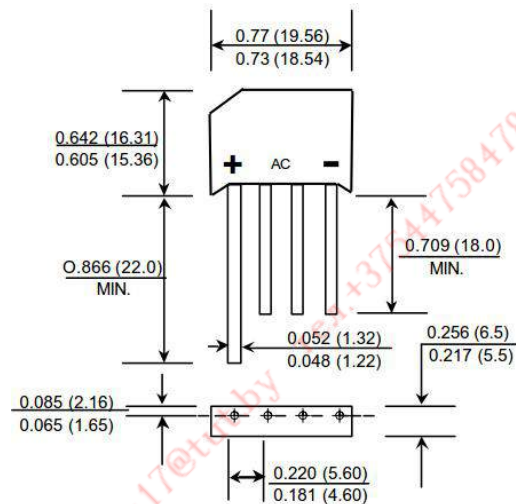
KBL**Dimensions in inches and (millimeters)****MAXIMUM RATINGS AND ELECTRICAL CHARACTERISTICS****Rating at 25°C ambient temperature unless otherwise specified.****Single phase, half wave, 60Hz, resistive or inductive load. For capacitive load, derate current by 20%**

PARAMETER	SYMBOL	KBL4005	KBL401	KBL402	KBL404	KBL406	KBL408	KBL410	UNIT
Maximum Recurrent Peak Reverse Voltage	V_{RRM}	50	100	200	400	600	800	1000	V
Maximum RMS Input Voltage	V_{RMS}	35	70	140	280	420	560	700	V
Maximum DC Blocking Voltage	V_{DC}	50	100	200	400	600	800	1000	V
Maximum Average Forward Output Current at 40°C T_A (Note 1)	$I_{(AV)}$	4.0							A
Peak Forward Surge Current 8.3ms single half sine-wave Super Imposed on Rated Load	I_{FSM}	150							A
Maximum forward Voltage Drop Per Element at 4.0A Peak	V_F	1.1							V
Maximum DC Reverse Current at Rated DC Blocking voltage	I_R	5.0							μA
Maximum Reverse Current at Rated DC Blocking voltage and 150°C T_A	I_R	1.0							mA
Operating Temperature Range T_J	T_J	-65 to +125							°C
Storage Temperature Range T_{STG}	T_{STG}	-65 to +150							°C

Note: 1. Mounting conditions, 0.5" lead length maximum.

KBL4005 THRU KBL410

SINGLE-PHASE BRIDGE RECTIFIER

REVERSE VOLTAGE 50 to 1000 Volts FORWARD CURRENT 4.0 Ampere

RATING AND CHARACTERISTIC CURVES KBL4005 THRU KBL410

FIG.1-DERATING CURVE FOR
OUTPUT RECTIFIED CURRENT

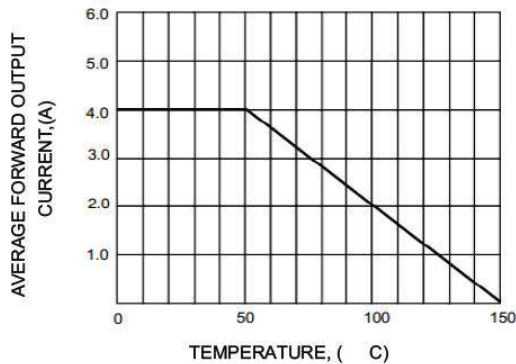

FIG.2-MAXIMUM NON-REPETITIVE PEAK
FORWARD SURGE CURRENT PER ELEMENT

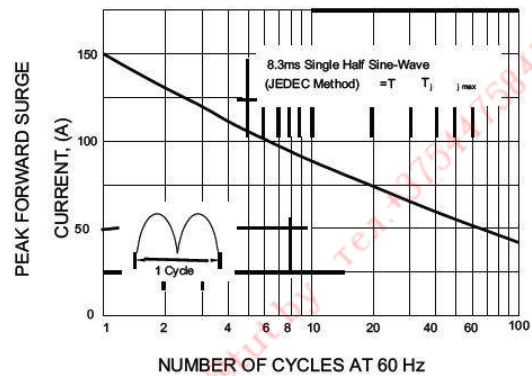

FIG.3-TYPICAL FORWARD CHARACTERISTICS
PER BRIDGE ELEMENT

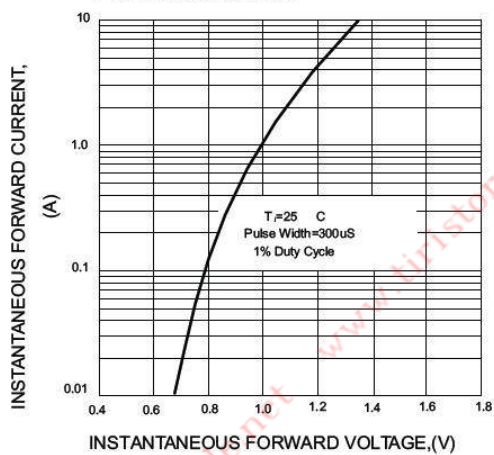

FIG.4-TYPICAL REVERSE CHARACTERISTICS
PER BRIDGE ELEMENT

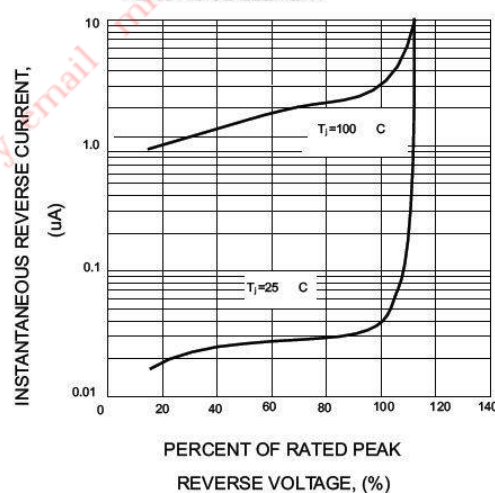
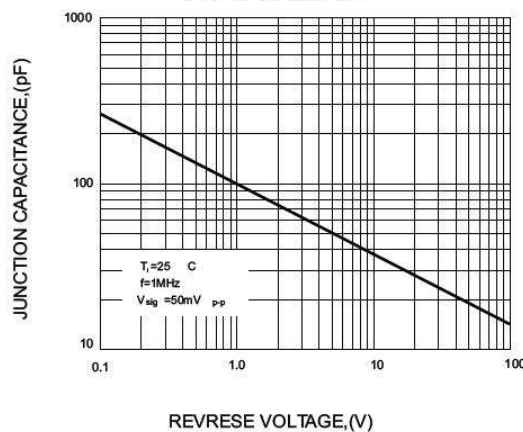

FIG.5-TYPICAL JUNCTION CAPACITANCE
PER BRIDGE ELEMENT



Note: Specifications are subject to change without notice. For more detail and update, please visit our website.

KBU6005 THRU KBU610

SINGLE-PHASE BRIDGE RECTIFIER

VOLTAGE RANGE 50 to 1000 Volts CURRENT 6.0 Ampere

FEATURES

- ◆ High forward surge current capability.
- ◆ Ideal for printed circuit board.
- ◆ High temperature soldering guaranteed:
260°C/10 second, 0.375" (9.5mm) lead length
at 5 lbs. (2.3kg) tension.

Mechanical Data

- ◆ Case: Transfer molded plastic.
- ◆ Terminal: Lead solderable per MIL - STD - 202E method 208°C.
- ◆ Polarity: Polarity symbols marked on case.
- ◆ Mounting: Thru hole for #6 screw, 5 in.- lbs. Torque Max.
- ◆ Weight: 0.27 ounce, 7.59 gram.

KBU

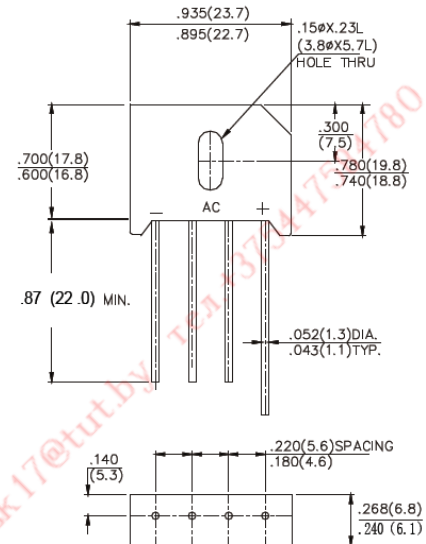

Dimensions in inches and (millimeters)

MAXIMUM RATINGS AND ELECTRICAL CHARACTERISTICS

Rating at 25°C ambient temperature unless otherwise specified.

Single phase, half wave, 60Hz, resistive or inductive load. For capacitive load, derate current by 20%

PARAMETER	SYMBOL	KBU 6005	KBU 601	KBU 602	KBU 604	KBU 606	KBU 608	KBU 610	UNIT
Maximum Repetitive Peak Reverse Voltage	V_{RRM}	50	100	200	400	600	800	1000	Volts
Maximum RMS Voltage	V_{RMS}	35	70	140	280	420	560	700	Volts
Maximum DC Blocking Voltage	V_{DC}	50	100	200	400	600	800	1000	Volts
Maximum Average Forward Rectified Output Current at $T_C=100^\circ C$	$I_{(AV)}$	6.0							Amps
Peak Forward Surge Current 8.3ms single half sine-wave superimposed on rated load (JEDEC Method)	I_{FSM}	150							Amps
Rating for Fusing($t < 8.3ms$)	I^2T	93							A^2s
Maximum Instantaneous Forward Voltage Drop per bridge element at 3.0A	V_F	1.0							Volts
Maximum DC Reverse Current at Rated DC Blocking Voltage per element	$T_A=25^\circ C$	10							μA
	$T_A=100^\circ C$	1.0							mA
Typical Junction Capacitance (Note 1)	C_j	105							pF
Typical Thermal Resistance (Note 2)	$R_{\theta JC}$	4.7							$^\circ C/W$
Operating Temperature Range	T_J	-65 to +150							$^\circ C$
Storage Temperature Range	T_{STG}	-65 to +150							

Note: 1. Measured at 1.0 MHz and applied reverse voltage of 4.0 Volts.

2. Unit mounted on 2.6" X 1.4" X 0.06" thick (6.3 X 3.5 X 0.15cm) Al. plate.

KBU6005 THRU KBU610

SINGLE-PHASE BRIDGE RECTIFIER

VOLTAGE RANGE 50 to 1000 Volts CURRENT 6.0 Ampere

RATING AND CHARACTERISTIC CURVES KBU6005 THRU KBU610

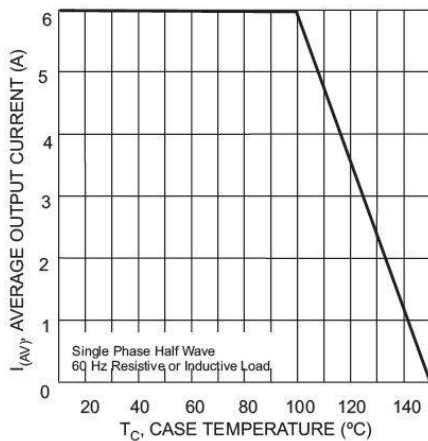

Fig. 1 Forward Current Derating Curve

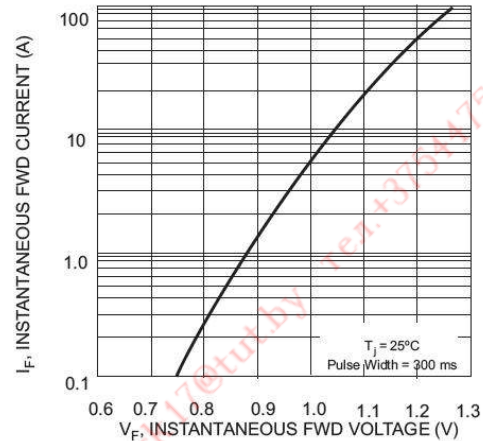

Fig. 2 Typical Forward Characteristics, per element

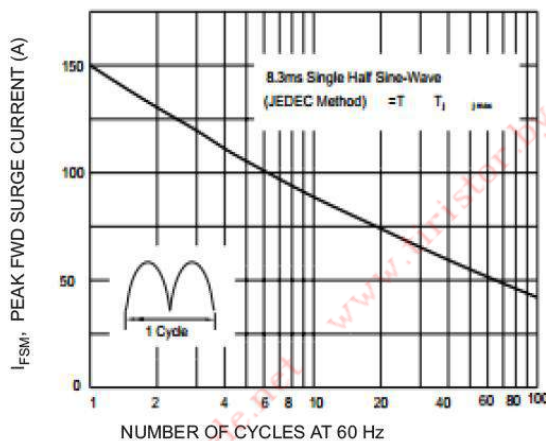

Fig. 3 Max Non-Repetitive Peak Fwd Surge Current

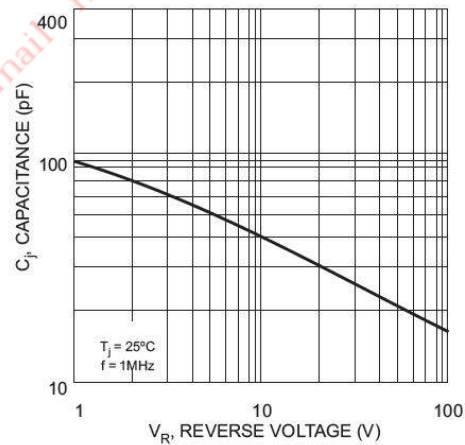

Fig. 4 Typical Junction Capacitance Per Element

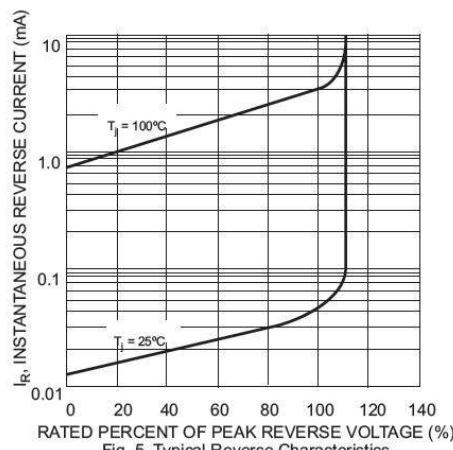

Fig. 5 Typical Reverse Characteristics

Note: Specifications are subject to change without notice. For more detail and update, please visit our website.

GBU401 THRU GBU410

SINGLE-PHASE BRIDGE RECTIFIER GLASS PASSIVATED BRIDGE RECTIFIERS
 REVERSE VOLTAGE 100 to 1000 Volts FORWARD CURRENT 4.0 Ampere

FEATURES

- ◆ Rating to 1000V PRV.
- ◆ Ideal for printed circuit board.
- ◆ Reliable low cost construction utilizing molded plastic Technique.
- ◆ The plastic material has UL flammability classification 94V-0.

Mechanical Data

- ◆ Polarity: As marked on Body.
- ◆ Weight: 0.15 ounces, 4.0 grams.
- ◆ Mounting position: Any.

GBU

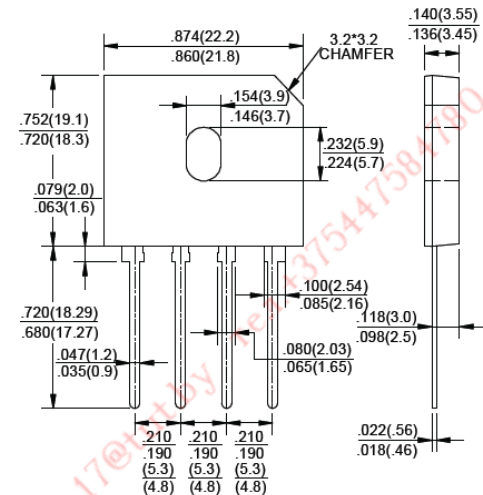

Dimensions in inches and (millimeters)

MAXIMUM RATINGS AND ELECTRICAL CHARACTERISTICS

Rating at 25°C ambient temperature unless otherwise specified.

Single phase, half wave, 60Hz, resistive or inductive load. For capacitive load, derate current by 20%

PARAMETER	SYMBOL	GBU401	GBU402	GBU404	GBU406	GBU408	GBU410	UNIT
Maximum Recurrent Peak Reverse Voltage	V_{RRM}	100	200	400	600	800	1000	V
Maximum RMS Voltage	V_{RMS}	70	140	280	420	560	700	V
Maximum DC Blocking Voltage	V_{DC}	100	200	400	600	800	1000	V
Maximum Average Forward(with heatsink Note 2) Rectified Current @ $T_C=100^\circ\text{C}$ (without heatsink)	$I_{(AV)}$	4.0 2.4						A
Peak Forward Surge Current 8.3ms single half sine-wave superimposed on rated load	I_{FSM}	150						A
Maximum forward Voltage at 2.0A DC	V_F	1.0						V
Maximum DC Reverse Current @ $T_J=25^\circ\text{C}$ at Rated DC Blocking voltage @ $T_J=125^\circ\text{C}$	I_R	5.0 500						μA
I^2t Rating for fusing($t<8.3\text{ms}$)	I^2t	93						A^2S
Typical Junction Capacitance per element(Note 1)	C_J	40						pF
Typical Thermal Resistance (Note 2)	$R_{\theta JC}$	3.0						$^\circ\text{C}/\text{W}$
Operating Temperature Range	T_J	-55 to +150						$^\circ\text{C}$
Storage Temperature Range	T_{STG}	-55 to +150						$^\circ\text{C}$

Note: 1. Measured at 1.0M Hz and applied reversed voltage of 4.0 VDC.

2. Device mounted on 50mm x 50mm x 1.6mm Cu Plate Heatsink.

GBU401 THRU GBU410

SINGLE-PHASE BRIDGE RECTIFIER GLASS PASSIVATED BRIDGE RECTIFIERS
 REVERSE VOLTAGE 100 to 1000 Volts FORWARD CURRENT 4.0 Ampere

RATING AND CHARACTERISTIC CURVES GBU401 THRU GBU410

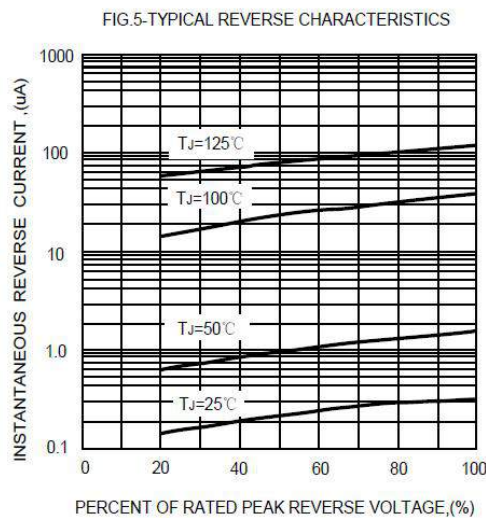
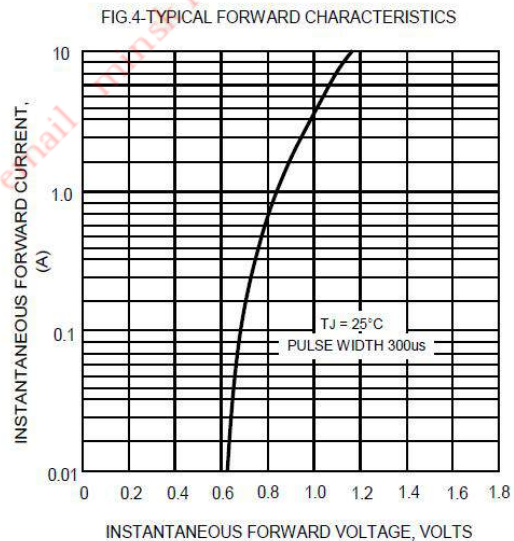
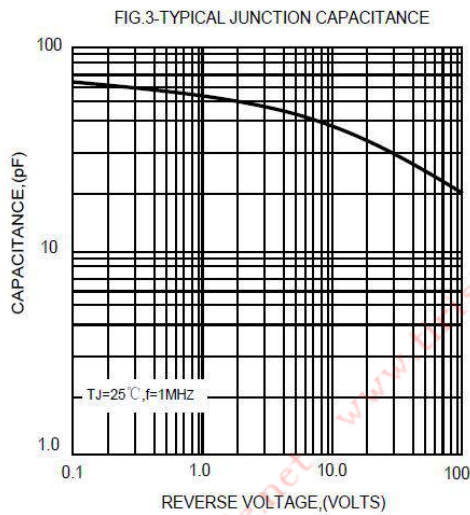
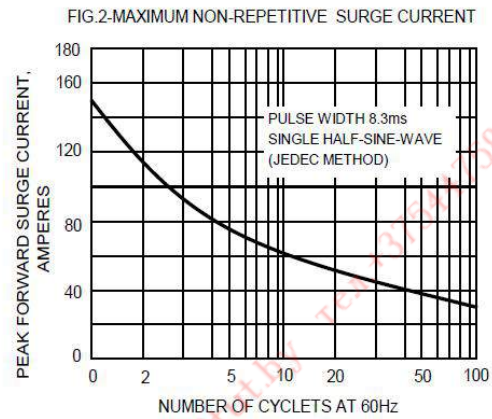
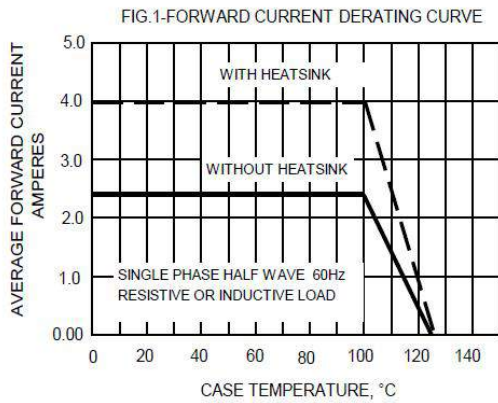

Note: Specifications are subject to change without notice. For more detail and update, please visit our website.

GBU6005 THRU GBU610

SINGLE-PHASE BRIDGE RECTIFIER GLASS PASSIVATED BRIDGE RECTIFIERS
 REVERSE VOLTAGE 50 to 1000 Volts FORWARD CURRENT 6.0 Ampere

FEATURES

- ◆ Rating to 1000V PRV
- ◆ Ideal for printed circuit board
- ◆ Reliable low cost construction utilizing molded plastic Technique
- ◆ The plastic material has UL flammability classification 94V-0
- ◆ Electrically isolated base-1500 Volts

Mechanical Data

- ◆ Polarity : As marked on Body
- ◆ Weight : 0.15 ounces, 4.0 grams
- ◆ Mounting position : Any

GBU

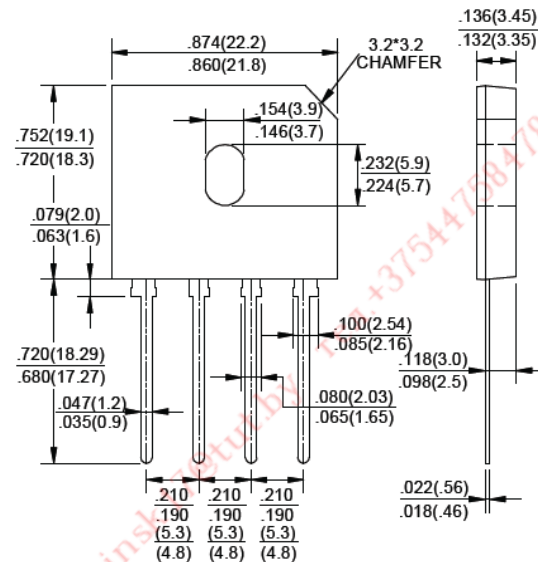

Dimensions in inches and (millimeters)

MAXIMUM RATINGS AND ELECTRICAL CHARACTERISTICS

Rating at 25°C ambient temperature unless otherwise specified.

Single phase, half wave, 60Hz, resistive or inductive load. For capacitive load, derate current by 20%

PARAMETER	SYMBOL	GBU 6005	GBU 601	GBU 602	GBU 604	GBU 606	GBU 608	GBU 610	UNIT
Maximum Recurrent Peak Reverse Voltage	V_{RRM}	50	100	200	400	600	800	1000	V
Maximum RMS Voltage	V_{RMS}	35	70	140	280	420	560	700	V
Maximum DC Blocking Voltage	V_{DC}	50	100	200	400	600	800	1000	V
Maximum Average Forward (with heatsink Note 2) Rectified Current, @ $T_c=100^\circ\text{C}$ (without heatsink)	$I_{(AV)}$					6.0			A
Peak Forward Surge Current 8.3ms single half sine-wave superimposed on rated load	I_{FSM}					175			A
Maximum Forward Voltage at 3.0A DC	V_F					1.0			V
Maximum DC Reverse Current @ $T_j = 25^\circ\text{C}$ at Rated DC blocking voltage @ $T_j = 125^\circ\text{C}$	I_R					5.0			μA
I^2t Rating for fusing ($t < 8.3\text{ms}$)	I^2t					127			A^2S
Typical Junction Capacitance per element (Note 1)	C_j					45			pF
Typical Thermal Resistance (Note 2)	$R_{\theta JC}$					2.2			$^\circ\text{C}/\text{W}$
Operating Temperature Range	T_j					-55 to +150			$^\circ\text{C}$
Storage Temperature Range	T_{STG}					-55 to +150			$^\circ\text{C}$

Note: 1. Measured at 1.0MHz and applied reverse voltage of 4.0V DC.

2. Device mounted on 75mm x 75mm x 1.6mm Cu Plate Heatsink.

GBU6005 THRU GBU610

SINGLE-PHASE BRIDGE RECTIFIER GLASS PASSIVATED BRIDGE RECTIFIERS
 REVERSE VOLTAGE 50 to 1000 Volts FORWARD CURRENT 6.0 Ampere

RATING AND CHARACTERISTIC CURVES GBU6005 THRU GBU610

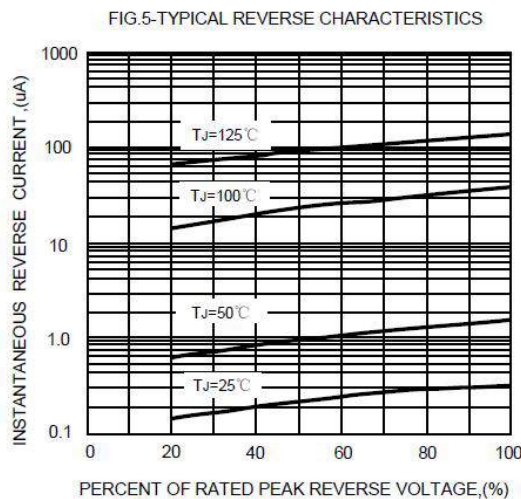
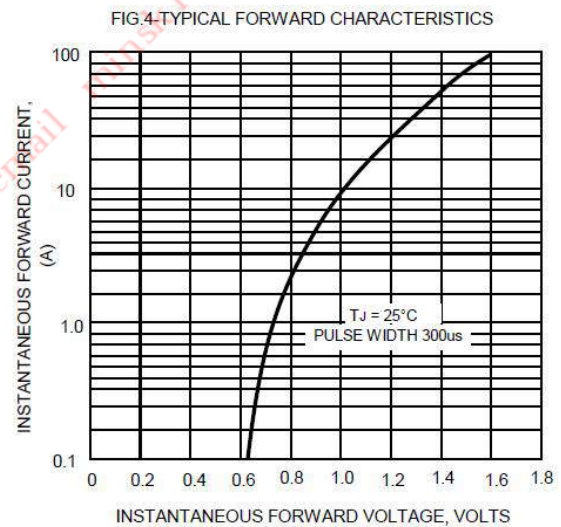
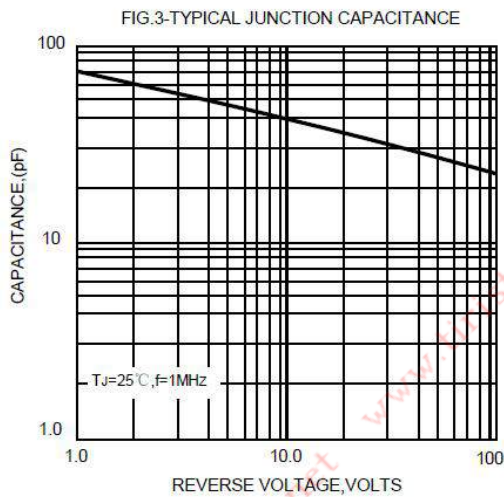
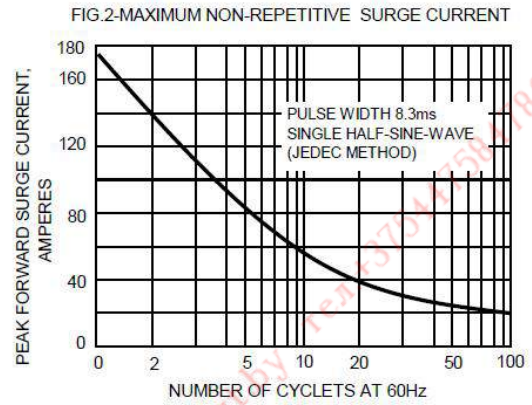
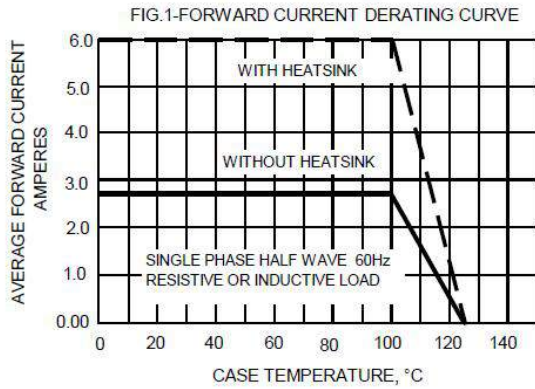

Note: Specifications are subject to change without notice. For more detail and update, please visit our website.

GBU8005 THRU GBU810

SINGLE-PHASE BRIDGE RECTIFIER GLASS PASSIVATED BRIDGE RECTIFIERS
 REVERSE VOLTAGE 50 to 1000 Volts FORWARD CURRENT 8.0 Ampere

FEATURES

- ◆ Rating to 1000V PRV
- ◆ Ideal for printed circuit board
- ◆ Reliable low cost construction utilizing molded plastic Technique
- ◆ The plastic material has UL flammability classification 94V-0
- ◆ Electrically isolated base-1500 Volts

Mechanical Data

- ◆ Polarity : Symbols molded on body
- ◆ Weight : 0.15 ounces, 4.0 grams
- ◆ Mounting position : Any

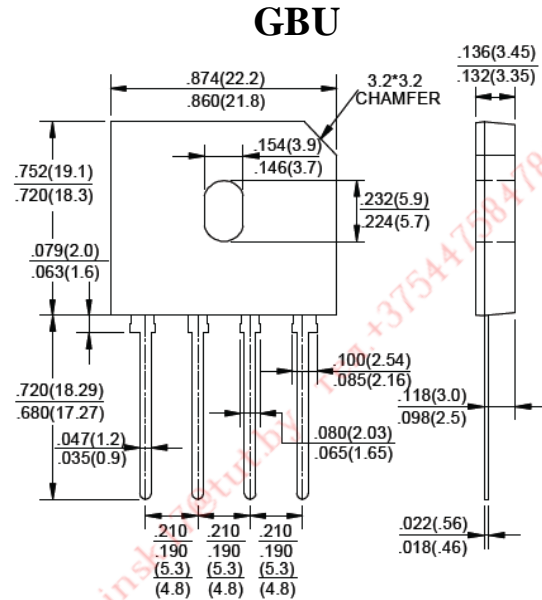

Dimensions in inches and (millimeters)

MAXIMUM RATINGS AND ELECTRICAL CHARACTERISTICS

Rating at 25°C ambient temperature unless otherwise specified.

Single phase, half wave, 60Hz, resistive or inductive load. For capacitive load, derate current by 20%

PARAMETER	SYMBOL	GBU 8005	GBU 801	GBU 802	GBU 804	GBU 806	GBU 808	GBU 810	UNIT
Maximum Recurrent Peak Reverse Voltage	V _{RRM}	50	100	200	400	600	800	1000	V
Maximum RMS Voltage	V _{RMS}	35	70	140	280	420	560	700	V
Maximum DC Blocking Voltage	V _{DC}	50	100	200	400	600	800	1000	V
Maximum Average Forward (with heatsink Note 2) Rectified Current, @ T _c =100°C(without heatsink)	I _(AV)	8.0							A
Peak Forward Surge Current 8.3ms single half sine-wave superimposed on rated load	I _{FSM}	200							A
Maximum Forward Voltage at 4.0A DC	V _F	1.0							V
Maximum DC Reverse Current @ T _J = 25°C at Rated DC blocking voltage @ T _J = 125°C	I _R	5.0							μA
I ² t Rating for fusing (t < 8.3ms)	I ² t	166							A ² S
Typical Junction Capacitance per element (Note 1)	C _J	60							pF
Typical Thermal Resistance (Note 2)	R _{θJC}	2.2							°C/W
Operating Temperature Range	T _J	-55 to +150							°C
Storage Temperature Range	T _{STG}	-55 to +150							°C

Note: 1. Measured at 1.0MHz and applied reverse voltage of 4.0V DC.

2. Device mounted on 100mm x 100mm x 1.6mm Cu Plate Heatsink.

GBU8005 THRU GBU810

SINGLE-PHASE BRIDGE RECTIFIER GLASS PASSIVATED BRIDGE RECTIFIERS
 REVERSE VOLTAGE 50 to 1000 Volts FORWARD CURRENT 8.0 Ampere

RATING AND CHARACTERISTIC CURVES GBU8005 THRU GBU810

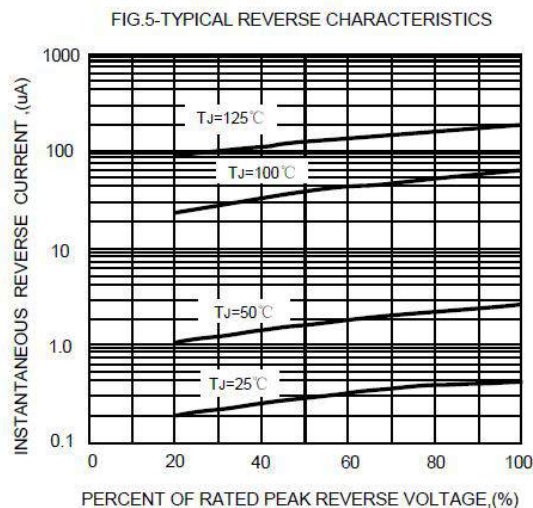
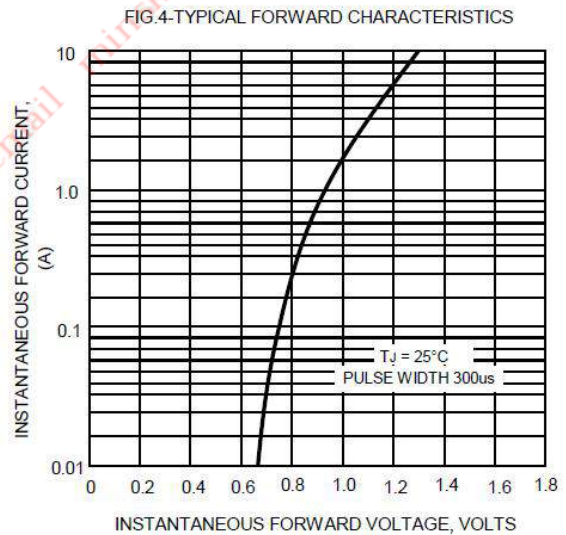
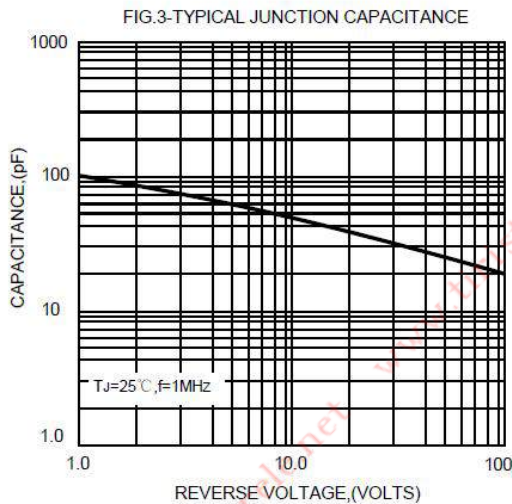
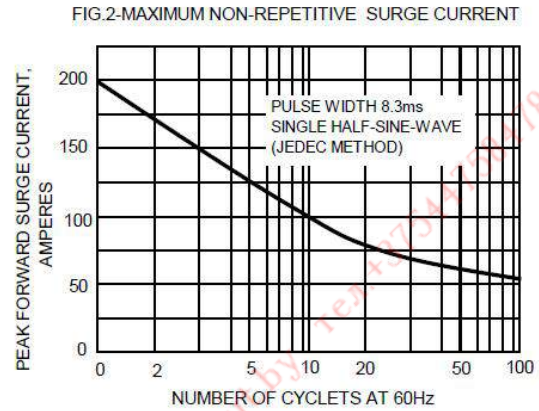
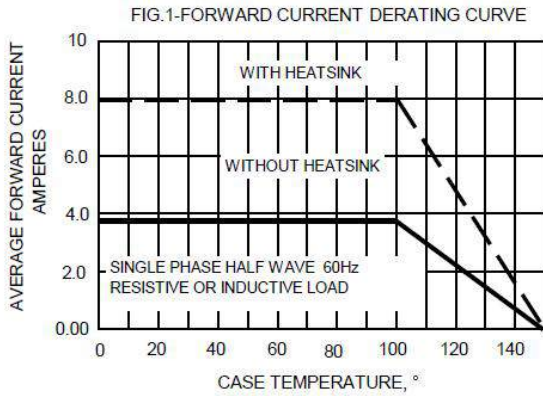

Note: Specifications are subject to change without notice. For more detail and update, please visit our website.

GBU10005 THRU GB1010

SINGLE-PHASE BRIDGE RECTIFIER GLASS PASSIVATED BRIDGE RECTIFIERS
 REVERSE VOLTAGE 50 to 1000 Volts FORWARD CURRENT 10 Ampere

FEATURES

- ◆ Rating to 1000V PRV
- ◆ Ideal for printed circuit board
- ◆ Reliable low cost construction utilizing molded plastic Technique
- ◆ The plastic material has UL flammability classification 94V-0
- ◆ Electrically isolated base-1500 Volts

Mechanical Data

- ◆ Polarity : As marked on Body
- ◆ Weight : 0.15 ounces, 4.0 grams
- ◆ Mounting position : Any

GBU

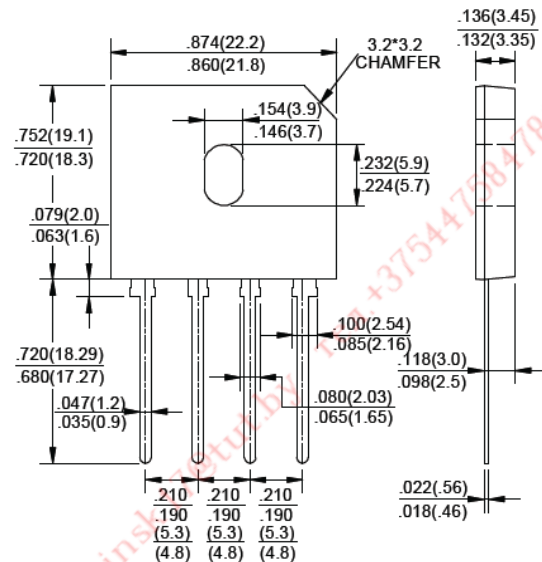

Dimensions in inches and (millimeters)

MAXIMUM RATINGS AND ELECTRICAL CHARACTERISTICS

Rating at 25°C ambient temperature unless otherwise specified.

Single phase, half wave, 60Hz, resistive or inductive load. For capacitive load, derate current by 20%

PARAMETER	SYMBOL	GBU 10005	GBU 1001	GBU 1002	GBU 1004	GBU 1006	GBU 1008	GBU 1010	UNIT
Maximum Recurrent Peak Reverse Voltage	V _{RRM}	50	100	200	400	600	800	1000	V
Maximum RMS Voltage	V _{RMS}	35	70	140	280	420	560	700	V
Maximum DC Blocking Voltage	V _{DC}	50	100	200	400	600	800	1000	V
Maximum Average Forward (with heatsink Note 2) Rectified Current, @ T _c =100°C(without heatsink)	I _(AV)	10							A
Peak Forward Surge Current 8.3ms single half sine-wave superimposed on rated load	I _{FSM}	220							A
Maximum Forward Voltage at 5.0A DC	V _F	1.0							V
Maximum DC Reverse Current @ T _J = 25°C at Rated DC blocking voltage @ T _J = 125°C	I _R	5.0							μA
I ² t Rating for fusing (t < 8.3ms)	I ² t	200							A ² S
Typical Junction Capacitance per element (Note 1)	C _J	60							pF
Typical Thermal Resistance (Note 2)	R _{θJC}	2.0							°C/W
Operating Temperature Range	T _J	-55 to +150							°C
Storage Temperature Range	T _{STG}	-55 to +150							°C

Note: 1. Measured at 1.0MHz and applied reverse voltage of 4.0V DC.

2. Device mounted on 150mm x 150mm x 1.6mm Cu Plate Heatsink.

GBU10005 THRU GB1010

SINGLE-PHASE BRIDGE RECTIFIER GLASS PASSIVATED BRIDGE RECTIFIERS
 REVERSE VOLTAGE 50 to 1000 Volts FORWARD CURRENT 10 Ampere

RATING AND CHARACTERISTIC CURVES GBU10005 THRU GB1010

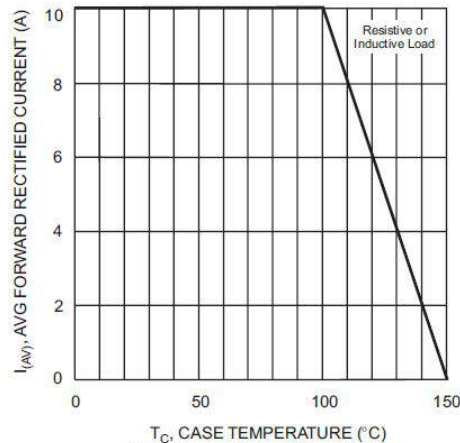

Fig. 1 Forward Current Derating Curve

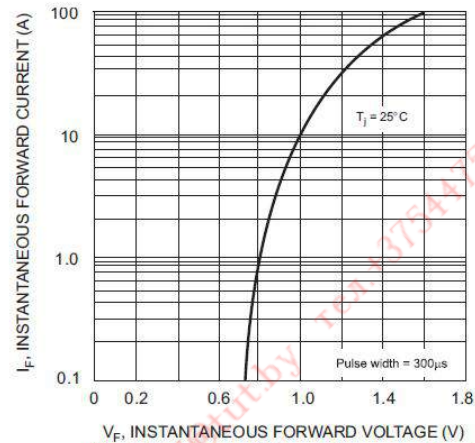

Fig. 2 Typical Forward Characteristics, per element

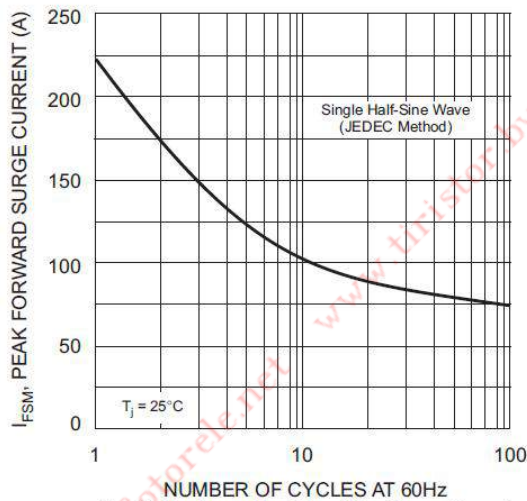

Fig. 3 Maximum Non-Repetitive Surge Current

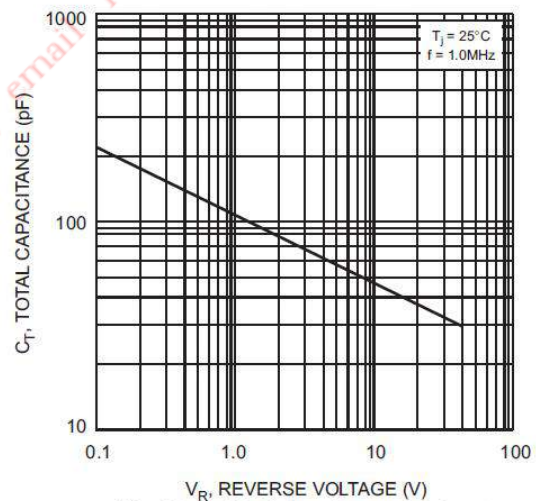
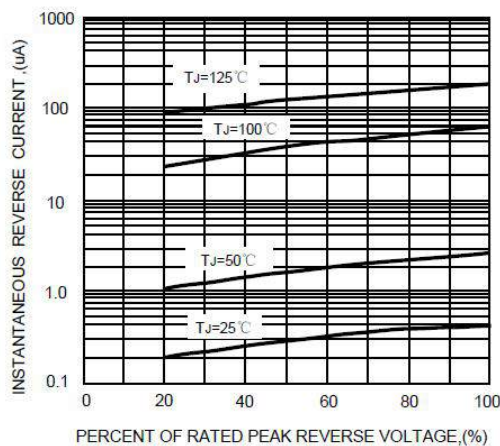

Fig. 4 Typical Total Capacitance, per element

FIG.5-TYPICAL REVERSE CHARACTERISTICS



Note: Specifications are subject to change without notice. For more detail and update, please visit our website.

GBU15005 THRU GBU1510

SINGLE-PHASE BRIDGE RECTIFIER GLASS PASSIVATED BRIDGE RECTIFIERS
 REVERSE VOLTAGE 50 to 1000 Volts FORWARD CURRENT 15 Ampere

FEATURES

- ◆ Rating to 1000V PRV
- ◆ Ideal for printed circuit board
- ◆ Reliable low cost construction utilizing molded plastic Technique
- ◆ The plastic material has UL flammability classification 94V-0
- ◆ Electrically isolated base-1500 Volts

Mechanical Data

- ◆ Polarity : As marked on Body
- ◆ Weight : 0.15 ounces, 4.0 grams
- ◆ Mounting position : Any

GBU

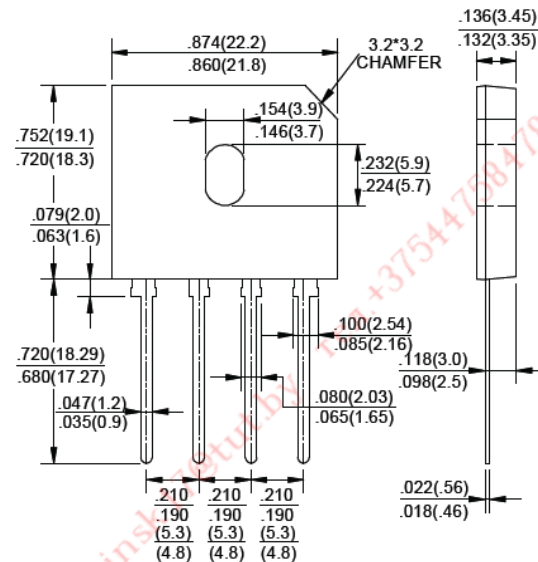

Dimensions in inches and (millimeters)

MAXIMUM RATINGS AND ELECTRICAL CHARACTERISTICS

Rating at 25°C ambient temperature unless otherwise specified.

Single phase, half wave, 60Hz, resistive or inductive load. For capacitive load, derate current by 20%

PARAMETER	SYMBOL	GBU 15005	GBU 1501	GBU 1502	GBU 1504	GBU 1506	GBU 1508	GBU 1510	UNIT	
Maximum Recurrent Peak Reverse Voltage	V_{RRM}	50	100	200	400	600	800	1000	V	
Maximum RMS Voltage	V_{RMS}	35	70	140	280	420	560	700	V	
Maximum DC Blocking Voltage	V_{DC}	50	100	200	400	600	800	1000	V	
Maximum Average Forward (with heatsink Note 2) Rectified Current, @ $T_C=100^\circ\text{C}$ (without heatsink)	$I_{(AV)}$	15								A
Peak Forward Surge Current 8.3ms single half sine-wave superimposed on rated load	I_{FSM}	240								A
Maximum Forward Voltage at 7.5A DC	V_F	1.1								V
Maximum DC Reverse Current @ $T_J = 25^\circ\text{C}$ at Rated DC blocking voltage @ $T_J = 125^\circ\text{C}$	I_R	5.0								μA
I^2t Rating for fusing ($t < 8.3\text{ms}$)	I^2t	166								A^2S
Typical Junction Capacitance per element (Note 1)	C_J	50								pF
Typical Thermal Resistance (Note 2)	$R_{\theta JC}$	2.0								$^\circ\text{C}/\text{W}$
Operating Temperature Range	T_J	-55 to +150								$^\circ\text{C}$
Storage Temperature Range	T_{STG}	-55 to +150								$^\circ\text{C}$

Note: 1. Measured at 1.0MHz and applied reverse voltage of 4.0V DC.

2. Device mounted on 200mm x 200mm x 5mm Al Plate Heatsink.

GBU15005 THRU GBU1510

SINGLE-PHASE BRIDGE RECTIFIER GLASS PASSIVATED BRIDGE RECTIFIERS
 REVERSE VOLTAGE 50 to 1000 Volts FORWARD CURRENT 15 Ampere

RATING AND CHARACTERISTIC CURVES GBU15005 THRU GBU1510

FIG.1- DERATING CURVE
 OUTPUT RECTIFIED CURRENT

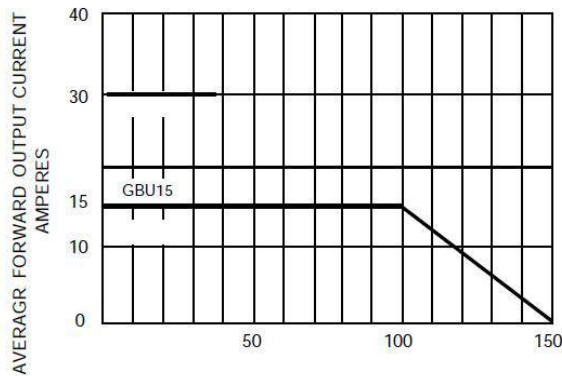

FIG.2-TYPICAL FORWARD
 CHARACTERISTICS

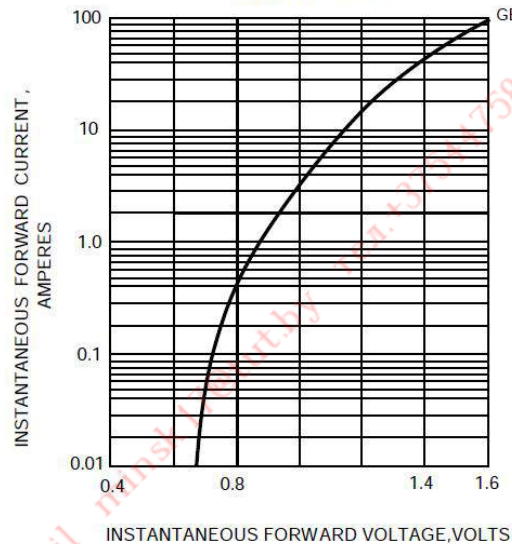

FIG.3-MAXIMUM FORWARD SURGE CURRENT

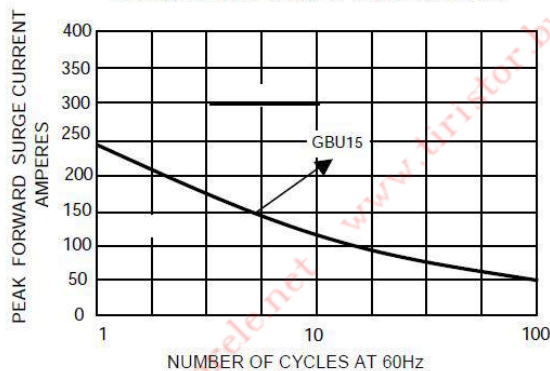

FIG.4-TYPICAL REVERSE
 CHARACTERISTICS

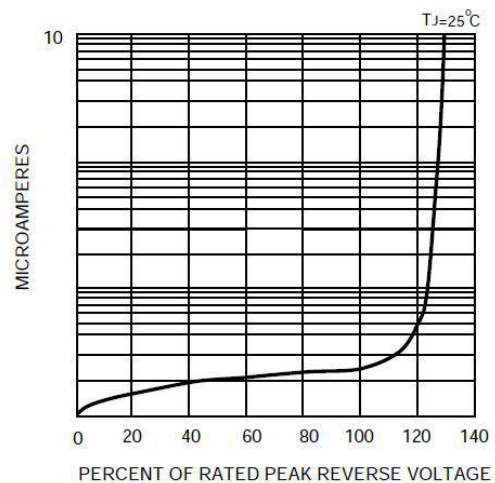
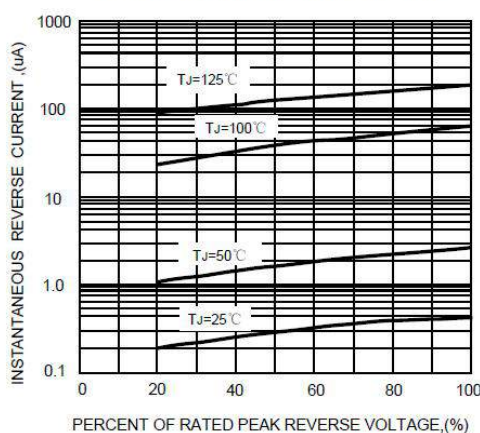

FIG.5-TYPICAL REVERSE CHARACTERISTICS



Note: Specifications are subject to change without notice. For more detail and update, please visit our website.

KBJ6005 THRU KBJ610

SINGLE-PHASE BRIDGE RECTIFIER GLASS PASSIVATED BRIDGE RECTIFIERS
REVERSE VOLTAGE 50 to 1000 Volts FORWARD CURRENT 6.0 Ampere

FEATURES

- ◆ Rating to 1000V PRV.
- ◆ Ideal for printed circuit board.
- ◆ Reliable low cost construction utilizing molded plastic Technique.
- ◆ The plastic material has UL flammability classification 94V-0.

- ◆ Electrically isolated base-1500 Volts.

Mechanical Data

- ◆ Polarity: Symbols molded on body.
- ◆ Weight: 0.15 ounces, 4.0 grams.
- ◆ Mounting position: Any.

KBJ

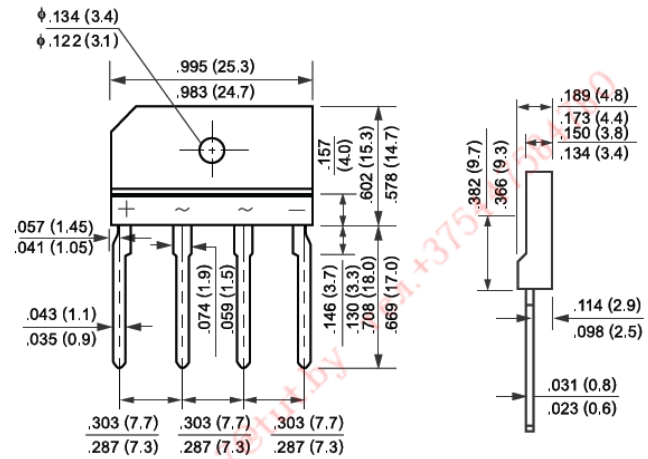

Dimensions in inches and (millimeters)

MAXIMUM RATINGS AND ELECTRICAL CHARACTERISTICS

Rating at 25°C ambient temperature unless otherwise specified.

Single phase, half wave, 60Hz, resistive or inductive load. For capacitive load, derate current by 20%

PARAMETER	SYMBOL	KBJ6005	KBJ601	KBJ602	KBJ604	KBJ606	KBJ608	KBJ610	UNIT
Maximum Recurrent Peak Reverse Voltage	V_{RRM}	50	100	200	400	600	800	1000	V
Maximum RMS Voltage	V_{RMS}	35	70	140	280	420	560	700	V
Maximum DC Blocking Voltage	V_{DC}	50	100	200	400	600	800	1000	V
Maximum Average Forward(with heatsink Note 2) Rectified Current @ $T_C=110^\circ\text{C}$ (without heatsink)	$I_{(AV)}$	6.0							A
Peak Forward Surge Current 8.3ms single half sine-wave superimposed on rated load (JEDEC METHOD)	I_{FSM}	170							A
Maximum forward Voltage at 3.0A DC	V_F	1.0							V
Maximum DC Reverse Current @ $T_J=25^\circ\text{C}$ at Rated DC Blocking voltage @ $T_J=125^\circ\text{C}$	I_R	5.0 500							μA
I^2t Rating for fusing($t<8.3\text{ms}$)	I^2t	120							A^2S
Typical Junction Capacitance per element(Note 1)	C_J	80							pF
Typical Thermal Resistance (Note 2)	$R_{\theta JC}$	1.5							$^\circ\text{C}/\text{W}$
Operating Temperature Range	T_J	-55 to +150							$^\circ\text{C}$
Storage Temperature Range	T_{STG}	-55 to +150							$^\circ\text{C}$

Note: 1. Measured at 1.0M Hz and applied reversed voltage of 4.0 VDC.

2. Unit Mounted on 75mm x 75mm x 1.6mm Cu Plate Heatsink.

KBJ6005 THRU KBJ610

SINGLE-PHASE BRIDGE RECTIFIER GLASS PASSIVATED BRIDGE RECTIFIERS
 REVERSE VOLTAGE 50 to 1000 Volts FORWARD CURRENT 6.0 Ampere

RATING AND CHARACTERISTIC CURVES KBJ6005 THRU KBJ610

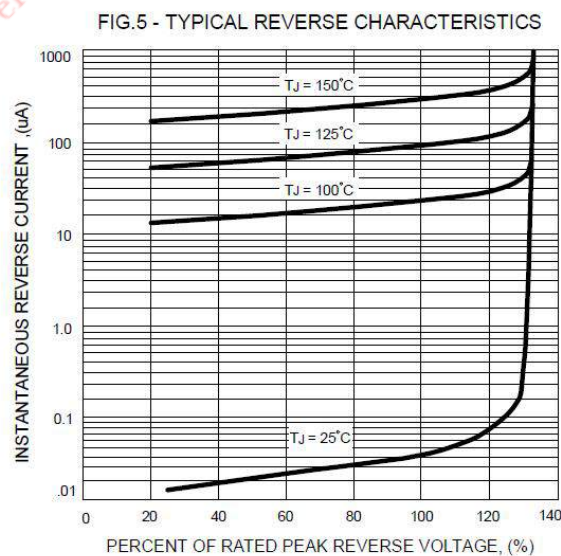
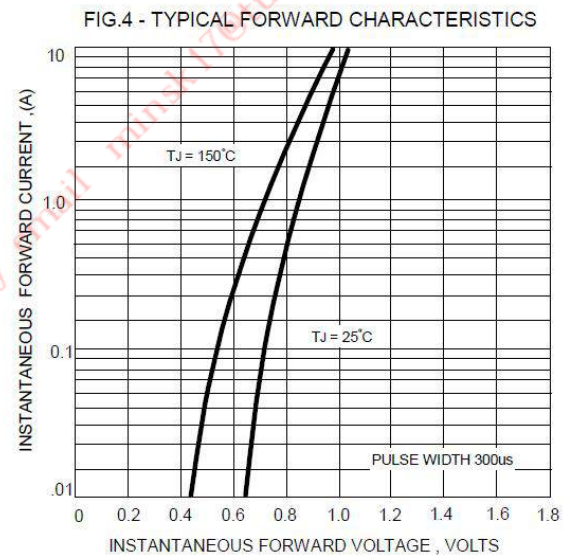
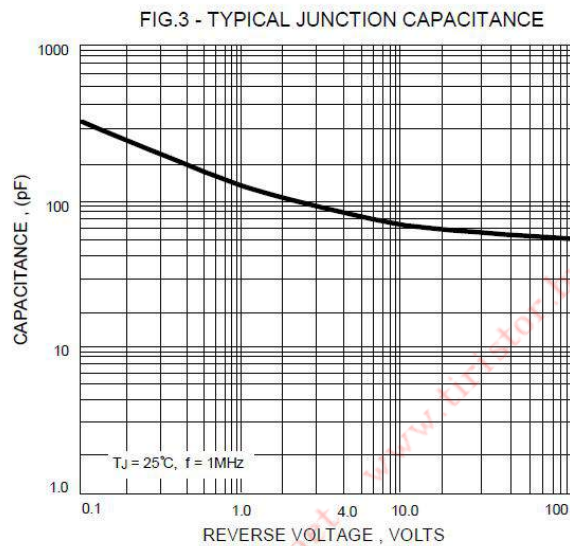
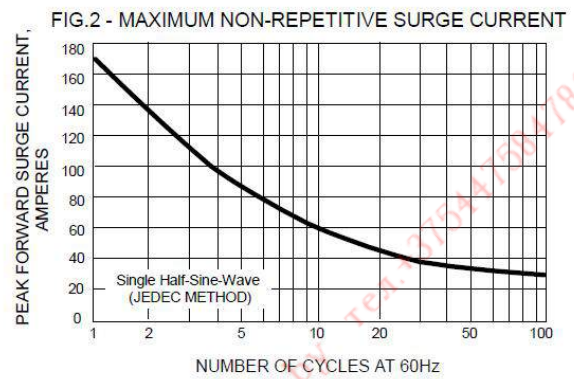
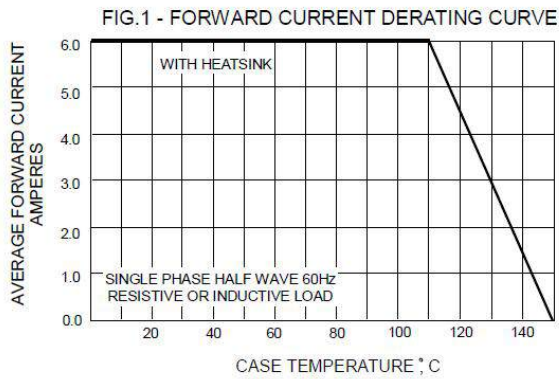

Note: Specifications are subject to change without notice. For more detail and update, please visit our website.

GBJ801 THRU GBJ810

SINGLE-PHASE BRIDGE RECTIFIER GLASS PASSIVATED BRIDGE RECTIFIERS
 REVERSE VOLTAGE 100 to 1000 Volts FORWARD CURRENT 8.0 Ampere

FEATURES

- ◆ Rating to 1000V PRV.
- ◆ Ideal for printed circuit board.
- ◆ Low forward voltage drop, high current capability.
- ◆ Reliable low cost construction utilizing molded plastic technique results in inexpensive product.
- ◆ The plastic material has UL flammability classification 94V-0.
- ◆ Electrically isolated base-1500 Volts

Mechanical Data

- ◆ Polarity: Symbols molded on body.
- ◆ Weight: 0.26 ounces, 7.0 grams.
- ◆ Mounting position: Any.

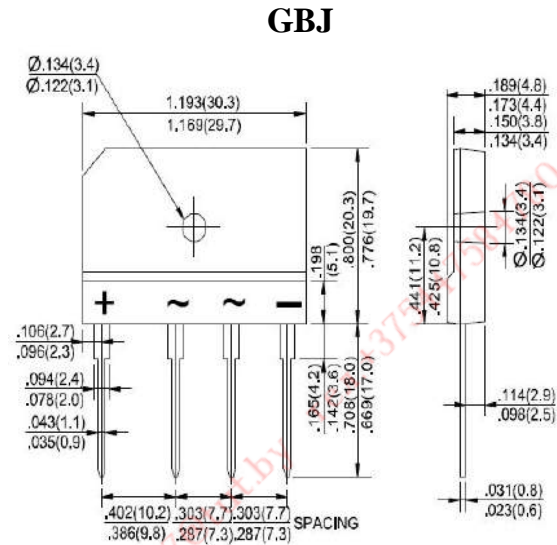

Dimensions in inches and (millimeters)

MAXIMUM RATINGS AND ELECTRICAL CHARACTERISTICS

Rating at 25°C ambient temperature unless otherwise specified.

Single phase, half wave, 60Hz, resistive or inductive load. For capacitive load, derate current by 20%

PARAMETER	SYMBOL	GBJ801	GBJ802	GBJ804	GBJ806	GBJ808	GBJ810	UNIT
Maximum Recurrent Peak Reverse Voltage	V_{RRM}	100	200	400	600	800	1000	V
Maximum RMS Voltage	V_{RMS}	70	140	280	420	560	700	V
Maximum DC Blocking Voltage	V_{DC}	100	200	400	600	800	1000	V
Maximum Average Forward (with heatsink Note 2) Rectified Current @ $T_C=110^\circ\text{C}$ (without heatsink)	$I_{(AV)}$	8.0 2.9						A
Peak Forward Surge Current 8.3ms single half sine-wave superimposed on rated load (JEDEC METHOD)	I_{FSM}	180						A
Maximum forward Voltage at 3.0A DC	V_F	1.0						V
Maximum DC Reverse Current @ $T_J=25^\circ\text{C}$ at Rated DC Blocking voltage @ $T_J=125^\circ\text{C}$	I_R	5.0 500						μA
I^2t Rating for fusing ($t < 8.3\text{ms}$)	I^2t	120						A^2S
Typical Junction Capacitance per element (Note 1)	C_J	55						pF
Typical Thermal Resistance (Note 2)	$R_{\theta JC}$	2.0						$^\circ\text{C}/\text{W}$
Operating Temperature Range	T_J	-55 to +150						$^\circ\text{C}$
Storage Temperature Range	T_{STG}	-55 to +150						$^\circ\text{C}$

Note: 1. Measured at 1.0M Hz and applied reversed voltage of 4.0 VDC.
 2. Device mounted on 100mm x 100mm x 1.6mm Cu Plate Heatsink.

GBJ801 THRU GBJ810

SINGLE-PHASE BRIDGE RECTIFIER GLASS PASSIVATED BRIDGE RECTIFIERS
 REVERSE VOLTAGE 100 to 1000 Volts FORWARD CURRENT 8.0 Ampere

RATING AND CHARACTERISTIC CURVES GBJ801 THRU GBJ810

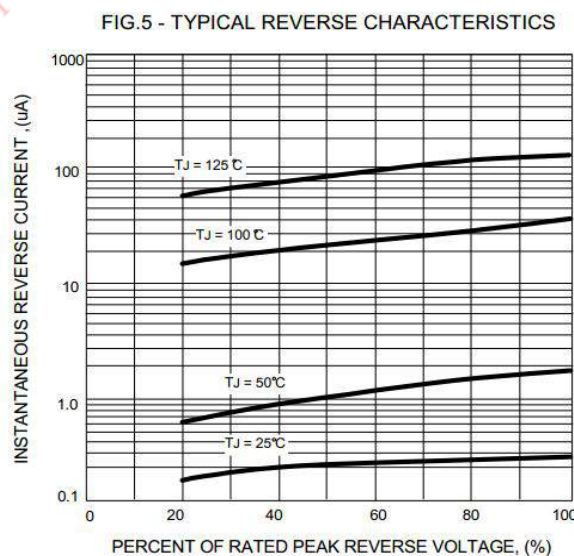
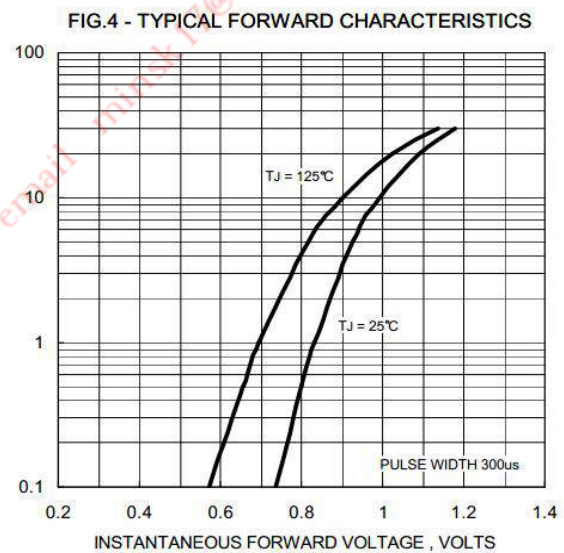
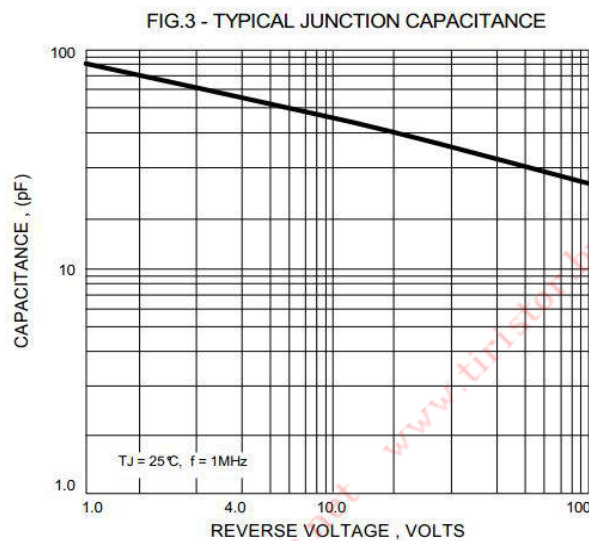
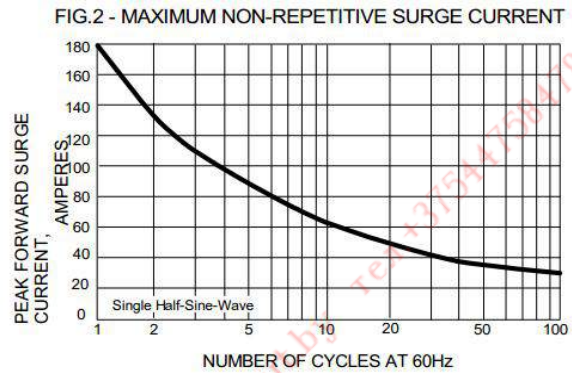
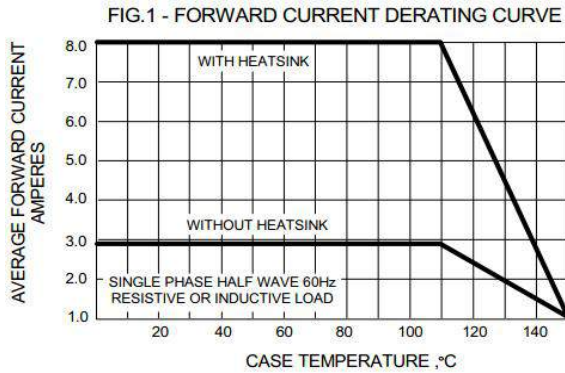

Note: Specifications are subject to change without notice. For more detail and update, please visit our website.

GBJ1001 THRU GBJ1010

SINGLE-PHASE BRIDGE RECTIFIER GLASS PASSIVATED BRIDGE RECTIFIERS
REVERSE VOLTAGE 100 to 1000 Volts FORWARD CURRENT 10 Ampere

FEATURES

- ◆ Rating to 1000V PRV.
- ◆ Ideal for printed circuit board.
- ◆ Low forward voltage drop, high current capability.
- ◆ Reliable low cost construction utilizing molded plastic technique results in inexpensive product.
- ◆ The plastic material has UL flammability classification 94V-0.

- ◆ Electrically isolated base-1500 Volts

Mechanical Data

- ◆ Polarity: Symbols molded on body.
- ◆ Weight: 0.26 ounces, 7.0 grams.
- ◆ Mounting position: Any.

GBJ

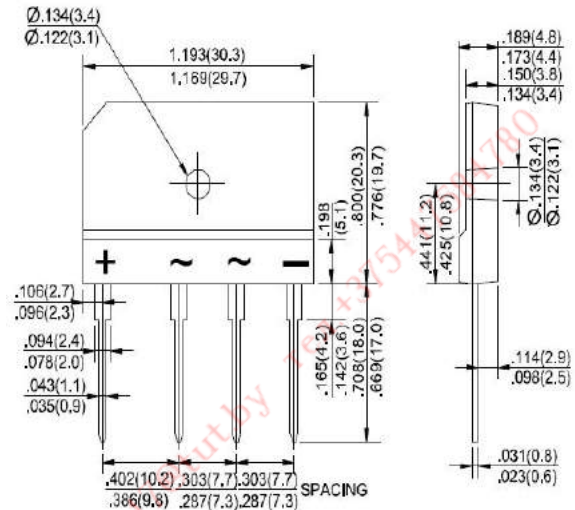

Dimensions in inches and (millimeters)

MAXIMUM RATINGS AND ELECTRICAL CHARACTERISTICS

Rating at 25°C ambient temperature unless otherwise specified.

Single phase, half wave, 60Hz, resistive or inductive load. For capacitive load, derate current by 20%

PARAMETER	SYMBOL	GBJ1001	GBJ1002	GBJ1004	GBJ1006	GBJ1008	GBJ1010	UNIT
Maximum Recurrent Peak Reverse Voltage	V_{RRM}	100	200	400	600	800	1000	V
Maximum RMS Voltage	V_{RMS}	70	140	280	420	560	700	V
Maximum DC Blocking Voltage	V_{DC}	100	200	400	600	800	1000	V
Maximum Average Forward (with heatsink Note 2) Rectified Current @ $T_C=110^\circ\text{C}$ (without heatsink)	$I_{(AV)}$	10.0 3.0						A
Peak Forward Surge Current 8.3ms single half sine-wave superimposed on rated load (JEDEC METHOD)	I_{FSM}	200						A
Maximum forward Voltage at 5.0A DC	V_F	1.0						V
Maximum DC Reverse Current @ $T_J=25^\circ\text{C}$ at Rated DC Blocking voltage @ $T_J=125^\circ\text{C}$	I_R	5.0 500						μA
I^2t Rating for fusing ($t < 8.3\text{ms}$)	I^2t	166						A^2S
Typical Junction Capacitance per element (Note 1)	C_J	55						pF
Typical Thermal Resistance (Note 2)	$R_{\theta JC}$	1.4						$^\circ\text{C}/\text{W}$
Operating Temperature Range	T_J	-55 to +150						$^\circ\text{C}$
Storage Temperature Range	T_{STG}	-55 to +150						$^\circ\text{C}$

Note: 1. Measured at 1.0M Hz and applied reversed voltage of 4.0 VDC.

2. Device mounted on 150mm x 150mm x 1.6mm Cu Plate Heatsink.

GBJ1001 THRU GBJ1010

SINGLE-PHASE BRIDGE RECTIFIER GLASS PASSIVATED BRIDGE RECTIFIER
 REVERSE VOLTAGE 100 to 1000 Volts FORWARD CURRENT 10 Ampere

RATING AND CHARACTERISTIC CURVES GBJ1001 THRU GBJ1010

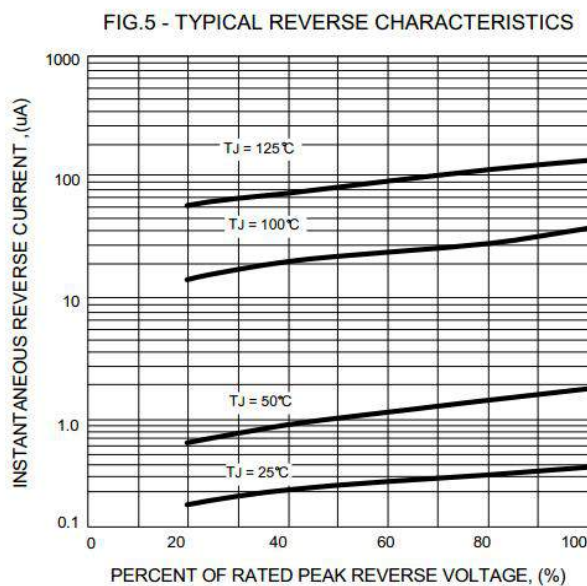
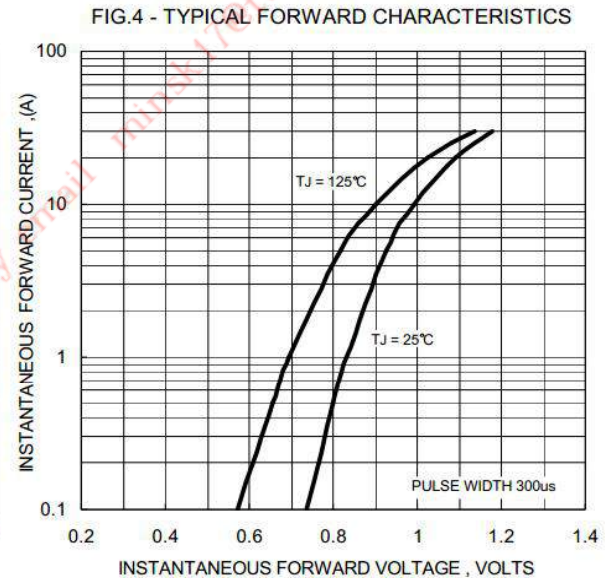
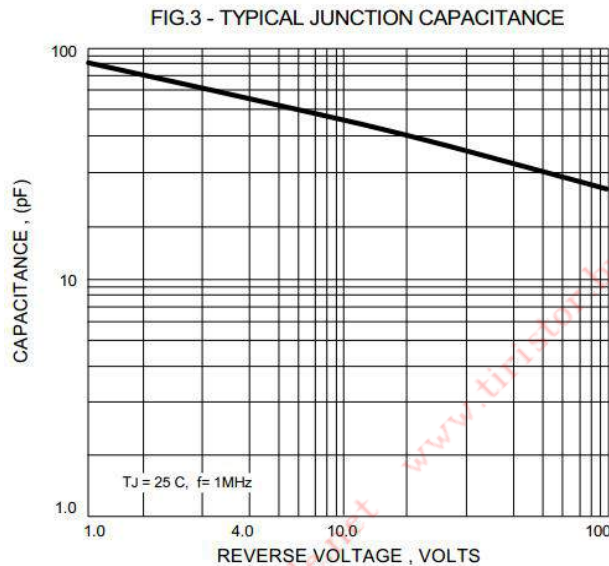
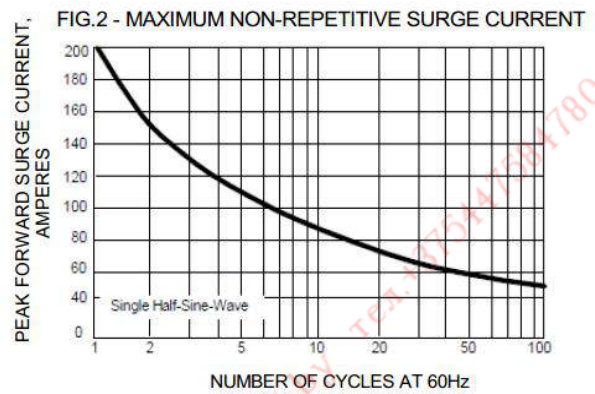
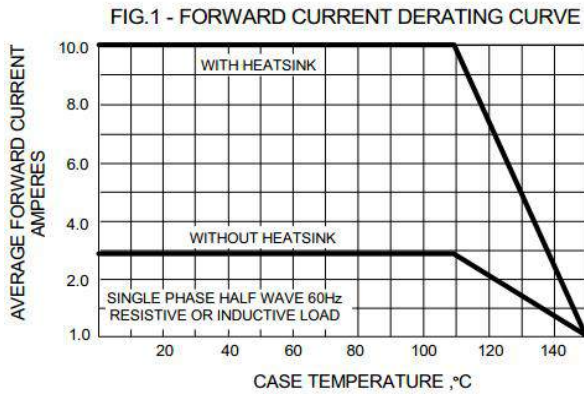

Note: Specifications are subject to change without notice. For more detail and update, please visit our website.

GBJ15005 THRU GBJ1510

SINGLE-PHASE BRIDGE RECTIFIER GLASS PASSIVATED BRIDGE RECTIFIERS
 REVERSE VOLTAGE 50 to 1000 Volts FORWARD CURRENT 15 Ampere

FEATURES

- ◆ Rating to 1000V PRV.
- ◆ Ideal for printed circuit board.
- ◆ Low forward voltage drop, high current capability.
- ◆ Reliable low cost construction utilizing molded plastic technique results in inexpensive product.
- ◆ The plastic material has UL flammability classification 94V-0.
- ◆ Electrically isolated base-1500 Volts

Mechanical Data

- ◆ Polarity: Symbols molded on body.
- ◆ Weight: 0.26 ounces, 7.0 grams.
- ◆ Mounting position: Any.

GBJ

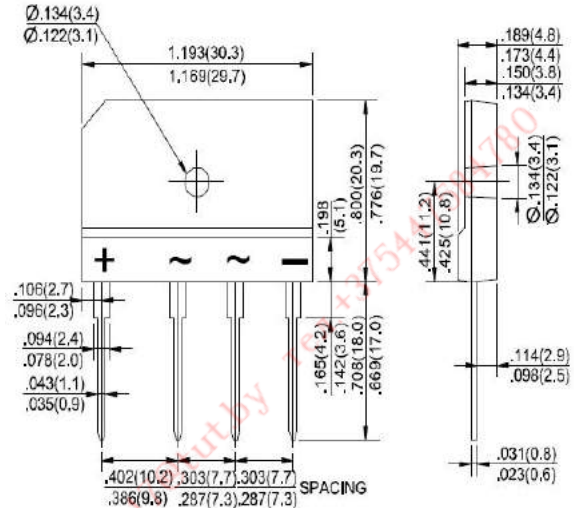

Dimensions in inches and (millimeters)

MAXIMUM RATINGS AND ELECTRICAL CHARACTERISTICS

Rating at 25°C ambient temperature unless otherwise specified.

Single phase, half wave, 60Hz, resistive or inductive load. For capacitive load, derate current by 20%

PARAMETER	SYMBOL	GBJ15005	GBJ1501	GBJ1502	GBJ1504	GBJ1506	GBJ1508	GBJ1510	UNIT
Maximum Recurrent Peak Reverse Voltage	V_{RRM}	50	100	200	400	600	800	1000	V
Maximum RMS Voltage	V_{RMS}	35	70	140	280	420	560	700	V
Maximum DC Blocking Voltage	V_{DC}	50	100	200	400	600	800	1000	V
Maximum Average Forward (with heatsink Note 2) Rectified Current @ $T_C=110^\circ\text{C}$ (without heatsink)	$I_{(AV)}$	15.0 3.2							A
Peak Forward Surge Current 8.3ms single half sine-wave superimposed on rated load (JEDEC METHOD)	I_{FSM}	240							A
Maximum forward Voltage at 7.5A DC	V_F	1.05							V
Maximum DC Reverse Current @ $T_J=25^\circ\text{C}$ at Rated DC Blocking voltage @ $T_J=125^\circ\text{C}$	I_R	5.0 500							μA
I^2t Rating for fusing ($t < 8.3\text{ms}$)	I^2t	240							A^2S
Typical Junction Capacitance per element (Note 1)	C_J	60							pF
Typical Thermal Resistance (Note 2)	$R_{\theta JC}$	0.8							$^\circ\text{C/W}$
Operating Temperature Range	T_J	-55 to +150							$^\circ\text{C}$
Storage Temperature Range	T_{STG}	-55 to +150							$^\circ\text{C}$

Note: 1. Measured at 1.0M Hz and applied reversed voltage of 4.0 VDC.
 2. Device mounted on 300mm x 300mm x 1.6mm Cu Plate Heatsink.

GBJ15005 THRU GBJ1510

SINGLE-PHASE BRIDGE RECTIFIER GLASS PASSIVATED BRIDGE RECTIFIER
 REVERSE VOLTAGE 50 to 1000 Volts FORWARD CURRENT 15 Ampere

RATING AND CHARACTERISTIC CURVES GBJ15005 THRU GBJ1510

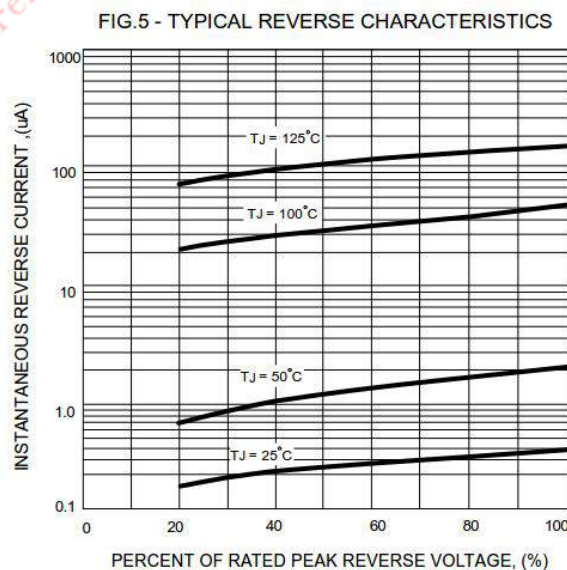
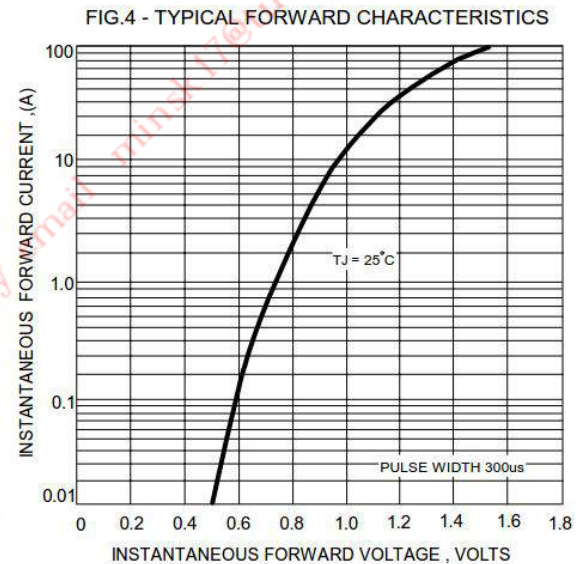
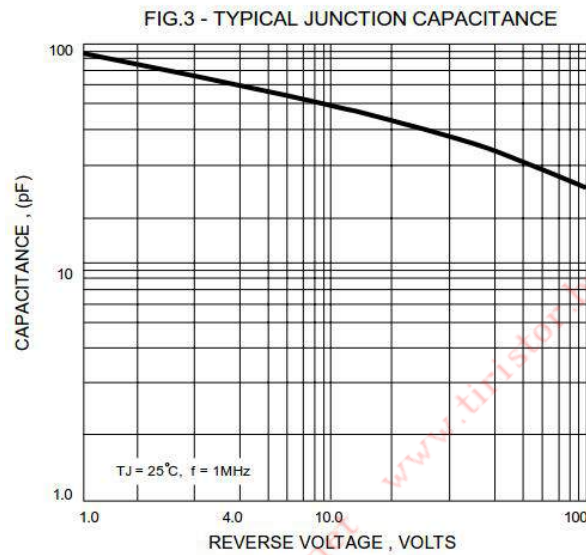
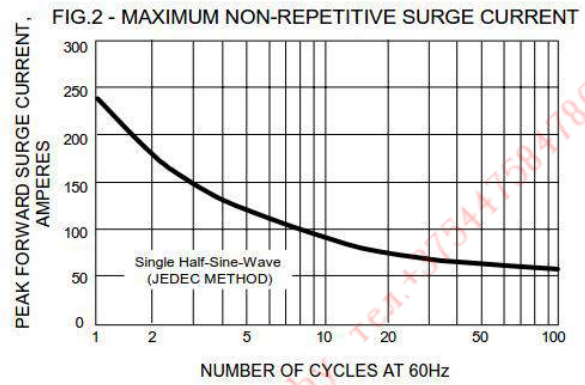
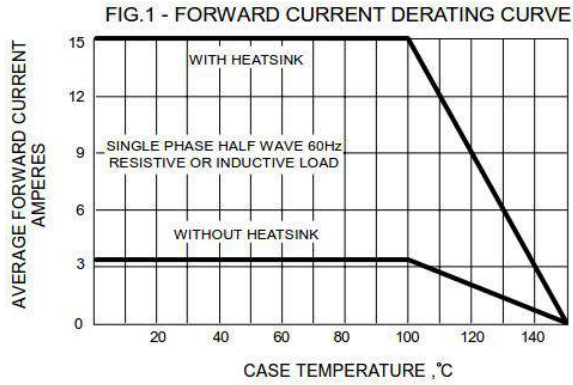

Note: Specifications are subject to change without notice. For more detail and update, please visit our website.

GBJ20005 THRU GBJ2010

SINGLE-PHASE BRIDGE RECTIFIER GLASS PASSIVATED BRIDGE RECTIFIERS
REVERSE VOLTAGE 50 to 1000 Volts FORWARD CURRENT 20 Ampere

FEATURES

- ◆ Rating to 1000V PRV.
- ◆ Ideal for printed circuit board.
- ◆ Low forward voltage drop, high current capability.
- ◆ Reliable low cost construction utilizing molded plastic technique results in inexpensive product.
- ◆ The plastic material has UL flammability classification 94V-0.

- ◆ Electrically isolated base-1500 Volts

Mechanical Data

- ◆ Polarity: Symbols molded on body.
- ◆ Weight: 0.26 ounces, 7.0 grams.
- ◆ Mounting position: Any.

GBJ

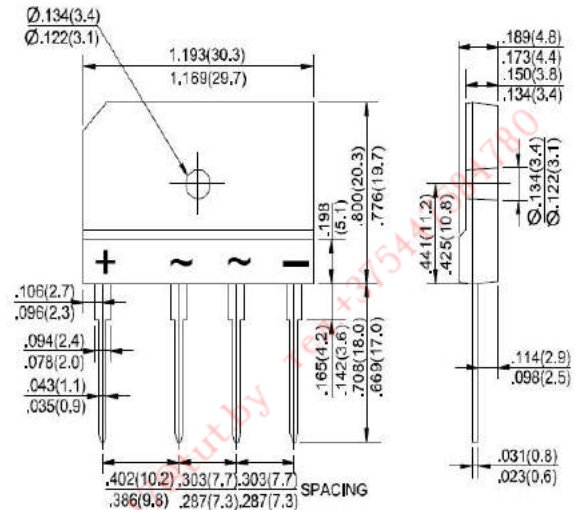

Dimensions in inches and (millimeters)

MAXIMUM RATINGS AND ELECTRICAL CHARACTERISTICS

Rating at 25°C ambient temperature unless otherwise specified.

Single phase, half wave, 60Hz, resistive or inductive load. For capacitive load, derate current by 20%

PARAMETER	SYMBOL	GBJ20005	GBJ2001	GBJ2002	GBJ2004	GBJ2006	GBJ2008	GBJ2010	UNIT	
Maximum Recurrent Peak Reverse Voltage	V_{RRM}	50	100	200	400	600	800	1000	V	
Maximum RMS Voltage	V_{RMS}	35	70	140	280	420	560	700	V	
Maximum DC Blocking Voltage	V_{DC}	50	100	200	400	600	800	1000	V	
Maximum Average Forward (with heatsink Note 2)	$I_{(AV)}$					20.0				A
Rectified Current @ $T_C=110^\circ\text{C}$ (without heatsink)						3.5				
Peak Forward Surge Current 8.3ms single half sine-wave superimposed on rated load (JEDEC METHOD)	I_{FSM}					260				A
Maximum forward Voltage at 10A DC	V_F					1.05				V
Maximum DC Reverse Current @ $T_J=25^\circ\text{C}$ at Rated DC Blocking voltage @ $T_J=125^\circ\text{C}$	I_R					5.0 500				μA
I^2t Rating for fusing ($t < 8.3\text{ms}$)	I^2t					240				A^2S
Typical Junction Capacitance per element (Note 1)	C_J					60				pF
Typical Thermal Resistance (Note 2)	$R_{\theta JC}$					0.8				$^\circ\text{C}/\text{W}$
Operating Temperature Range	T_J					-55 to +150				$^\circ\text{C}$
Storage Temperature Range	T_{STG}					-55 to +150				$^\circ\text{C}$

Note: 1. Measured at 1.0M Hz and applied reversed voltage of 4.0 VDC.

2. Device mounted on 300mm x 300mm x 1.6mm Cu Plate Heatsink.

GBJ20005 THRU GBJ2010

SINGLE-PHASE BRIDGE RECTIFIER GLASS PASSIVATED BRIDGE RECTIFIER
 REVERSE VOLTAGE 50 to 1000 Volts FORWARD CURRENT 20 Ampere

RATING AND CHARACTERISTIC CURVES GBJ20005 THRU GBJ2010

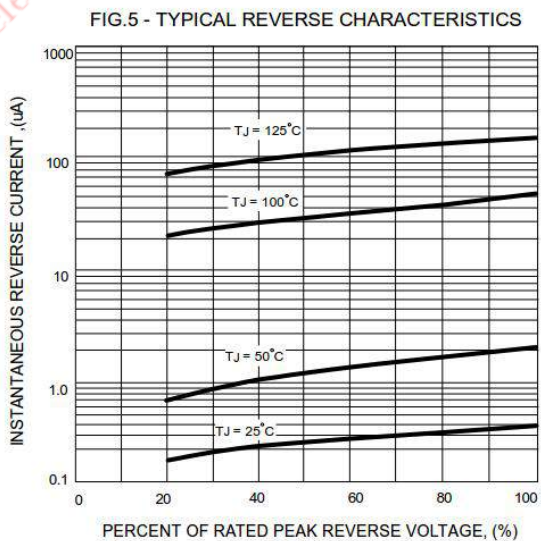
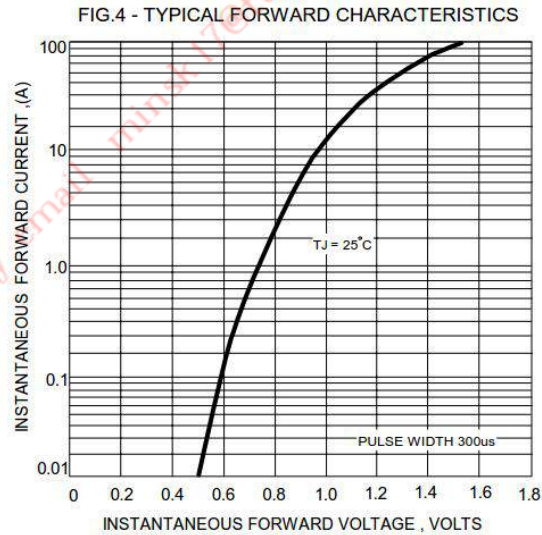
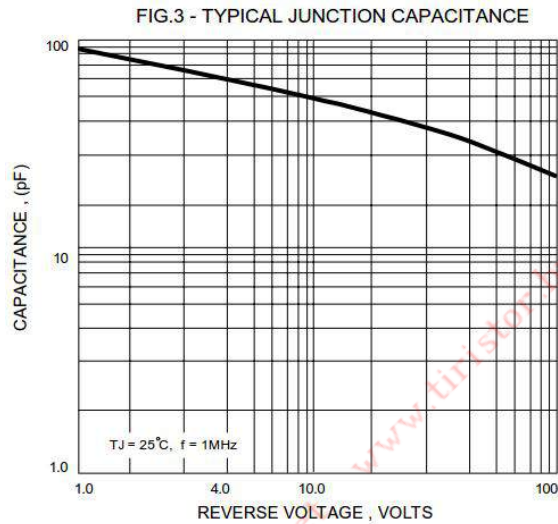
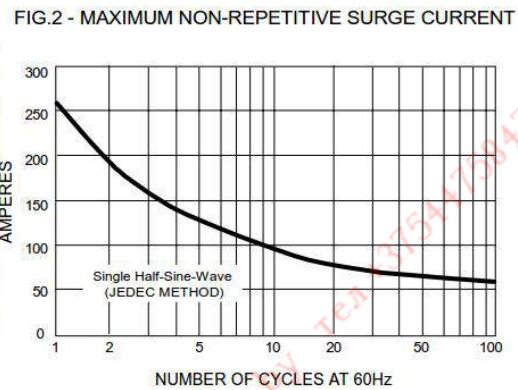
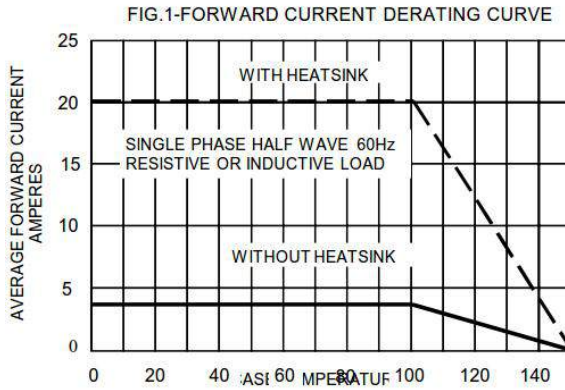

Note: Specifications are subject to change without notice. For more detail and update, please visit our website.

GBJ2501 THRU GBJ2510

SINGLE-PHASE BRIDGE RECTIFIER GLASS PASSIVATED BRIDGE RECTIFIERS
REVERSE VOLTAGE 100 to 1000 Volts FORWARD CURRENT 25 Ampere

FEATURES

- ◆ Rating to 1000V PRV.
- ◆ Ideal for printed circuit board.
- ◆ Low forward voltage drop, high current capability.
- ◆ Reliable low cost construction utilizing molded plastic technique results in inexpensive product.
- ◆ The plastic material has UL flammability classification 94V-0.
- ◆ Electrically isolated base-1500 Volts

Mechanical Data

- ◆ Polarity: Symbols molded on body.
- ◆ Weight: 0.26 ounces, 7.0 grams.
- ◆ Mounting position: Any.

GBJ

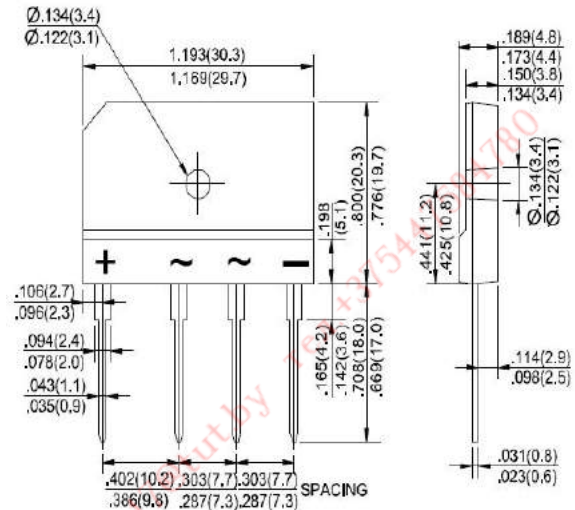

Dimensions in inches and (millimeters)

MAXIMUM RATINGS AND ELECTRICAL CHARACTERISTICS

Rating at 25°C ambient temperature unless otherwise specified.

Single phase, half wave, 60Hz, resistive or inductive load. For capacitive load, derate current by 20%

PARAMETER	SYMBOL	GBJ2501	GBJ202	GBJ2504	GBJ2506	GBJ2508	GBJ2510	UNIT
Maximum Recurrent Peak Reverse Voltage	V_{RRM}	100	200	400	600	800	1000	V
Maximum RMS Voltage	V_{RMS}	70	140	280	420	560	700	V
Maximum DC Blocking Voltage	V_{DC}	100	200	400	600	800	1000	V
Maximum Average Forward (with heatsink Note 2) Rectified Current @ $T_C=110^\circ\text{C}$ (without heatsink)	$I_{(AV)}$	25.0 4.2						A
Peak Forward Surge Current 8.3ms single half sine-wave superimposed on rated load (JEDEC METHOD)	I_{FSM}	300						A
Maximum forward Voltage at 12.5A DC	V_F	1.0						V
Maximum DC Reverse Current @ $T_J=25^\circ\text{C}$ at Rated DC Blocking voltage @ $T_J=125^\circ\text{C}$	I_R	5.0 500						μA
I^2t Rating for fusing ($t < 8.3\text{ms}$)	I^2t	510						A^2S
Typical Junction Capacitance per element (Note 1)	C_J	85						pF
Typical Thermal Resistance (Note 2)	$R_{\theta JC}$	1.0						$^\circ\text{C}/\text{W}$
Operating Temperature Range	T_J	-55 to +150						$^\circ\text{C}$
Storage Temperature Range	T_{STG}	-55 to +150						$^\circ\text{C}$

Note: 1. Measured at 1.0M Hz and applied reversed voltage of 4.0 VDC.

2. Device mounted on 75mm x 75mm x 1.6mm Cu Plate Heatsink.

GBJ2501 THRU GBJ2510

SINGLE-PHASE BRIDGE RECTIFIER GLASS PASSIVATED BRIDGE RECTIFIER
 REVERSE VOLTAGE 100 to 1000 Volts FORWARD CURRENT 25 Ampere

RATING AND CHARACTERISTIC CURVES GBJ2501 THRU GBJ2510

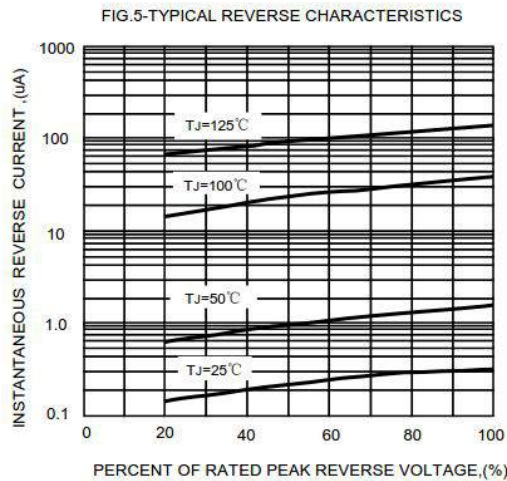
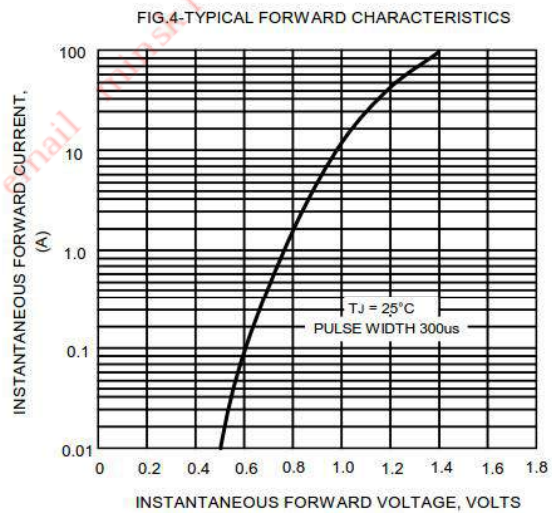
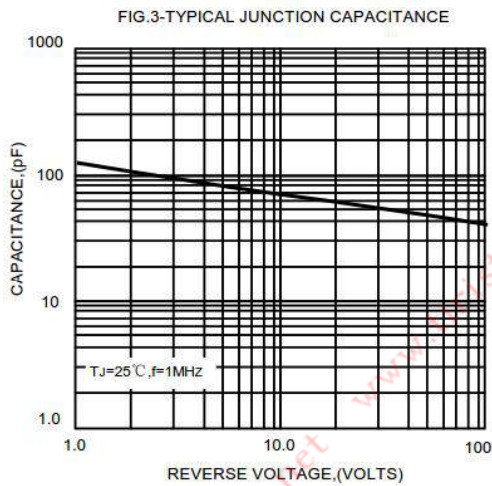
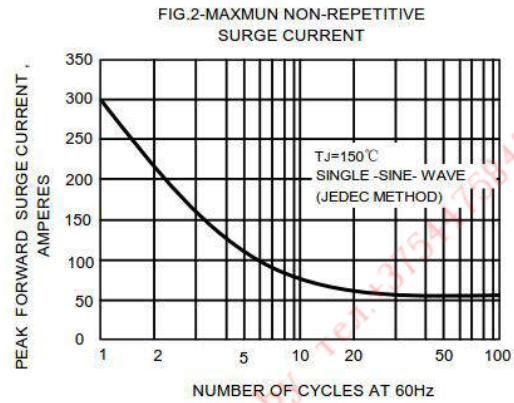
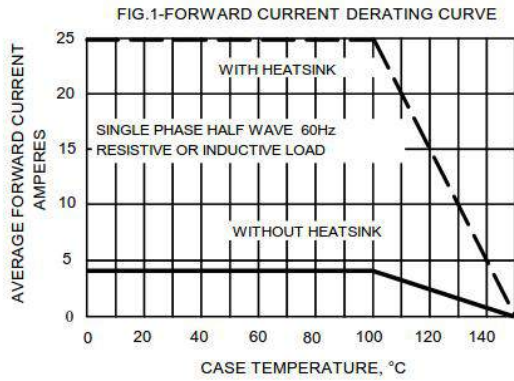

Note: Specifications are subject to change without notice. For more detail and update, please visit our website.

GBJ3501 THRU GBJ3510

SINGLE-PHASE BRIDGE RECTIFIER GLASS PASSIVATED BRIDGE RECTIFIERS
REVERSE VOLTAGE 100 to 1000 Volts FORWARD CURRENT 35 Ampere

FEATURES

- ◆ Rating to 1000V PRV.
- ◆ Ideal for printed circuit board.
- ◆ Low forward voltage drop, high current capability.
- ◆ Reliable low cost construction utilizing molded plastic technique results in inexpensive product.
- ◆ The plastic material has UL flammability classification 94V-0.

- ◆ Electrically isolated base-1500 Volts

Mechanical Data

- ◆ Polarity: Symbols molded on body.
- ◆ Weight: 0.26 ounces, 7.0 grams.
- ◆ Mounting position: Any.

GBJ

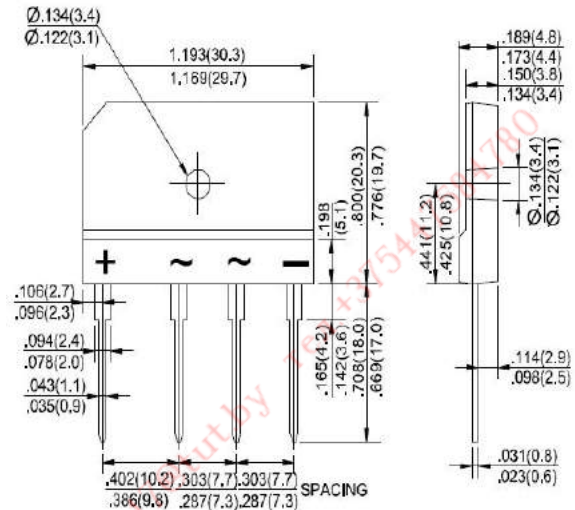

Dimensions in inches and (millimeters)

MAXIMUM RATINGS AND ELECTRICAL CHARACTERISTICS

Rating at 25°C ambient temperature unless otherwise specified.

Single phase, half wave, 60Hz, resistive or inductive load. For capacitive load, derate current by 20%

PARAMETER	SYMBOL	GBJ35005	GBJ3501	GBJ3502	GBJ3504	GBJ3506	GBJ3508	GBJ3510	UNIT
Maximum Recurrent Peak Reverse Voltage	V_{RRM}	50	100	200	400	600	800	1000	V
Maximum RMS Voltage	V_{RMS}	35	70	140	280	420	560	700	V
Maximum DC Blocking Voltage	V_{DC}	50	100	200	400	600	800	1000	V
Maximum Average Forward (with heatsink Note 2) Rectified Current @ $T_C=110^\circ\text{C}$ (without heatsink)	$I_{(AV)}$				35.0 5.0				A
Peak Forward Surge Current 8.3ms single half sine-wave superimposed on rated load (JEDEC METHOD)	I_{FSM}				400				A
Maximum forward Voltage at 17.5A DC	V_F				1.1				V
Maximum DC Reverse Current @ $T_J=25^\circ\text{C}$ at Rated DC Blocking voltage @ $T_J=125^\circ\text{C}$	I_R				10.0 500				μA
I^2t Rating for fusing ($t < 8.3\text{ms}$)	I^2t				510				A^2S
Typical Junction Capacitance per element (Note 1)	C_J				85				pF
Typical Thermal Resistance (Note 2)	$R_{\theta JC}$				0.6				$^\circ\text{C}/\text{W}$
Operating Temperature Range	T_J				-55 to +150				$^\circ\text{C}$
Storage Temperature Range	T_{STG}				-55 to +150				$^\circ\text{C}$

Note: 1. Measured at 1.0M Hz and applied reversed voltage of 4.0 VDC.

2. Device mounted on 300mm x 300mm x 1.6mm Cu Plate Heatsink.

GBJ3501 THRU GBJ3510

SINGLE-PHASE BRIDGE RECTIFIER GLASS PASSIVATED BRIDGE RECTIFIER
 REVERSE VOLTAGE 100 to 1000 Volts FORWARD CURRENT 35 Ampere

RATING AND CHARACTERISTIC CURVES GBJ3501 THRU GBJ3510

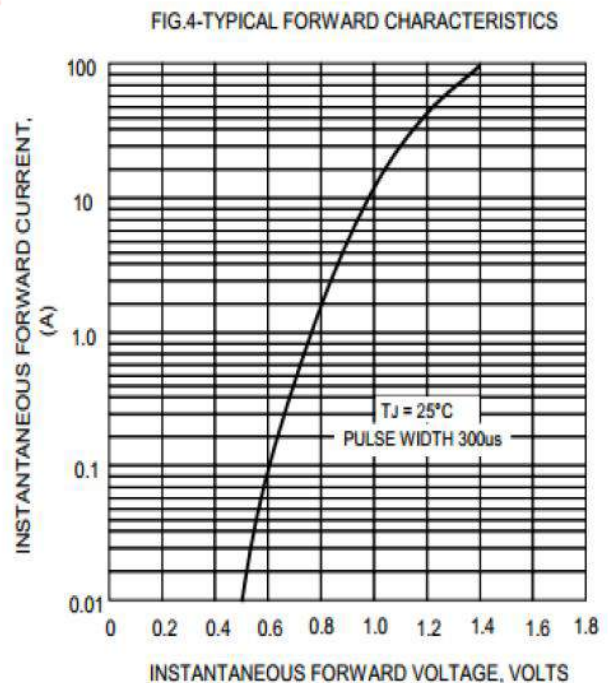
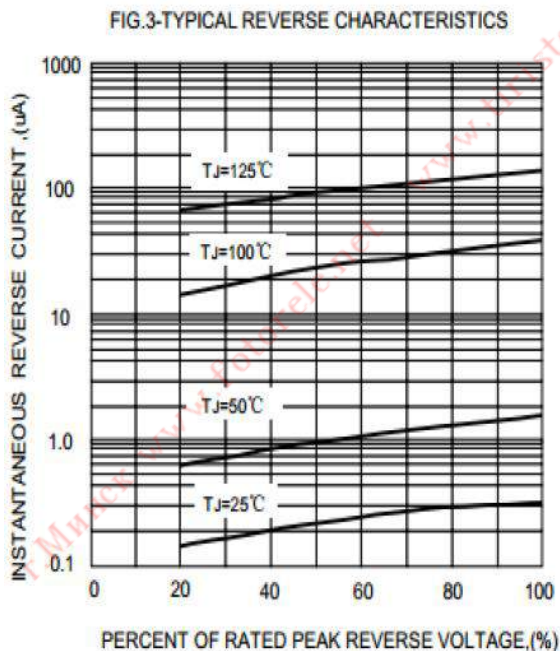
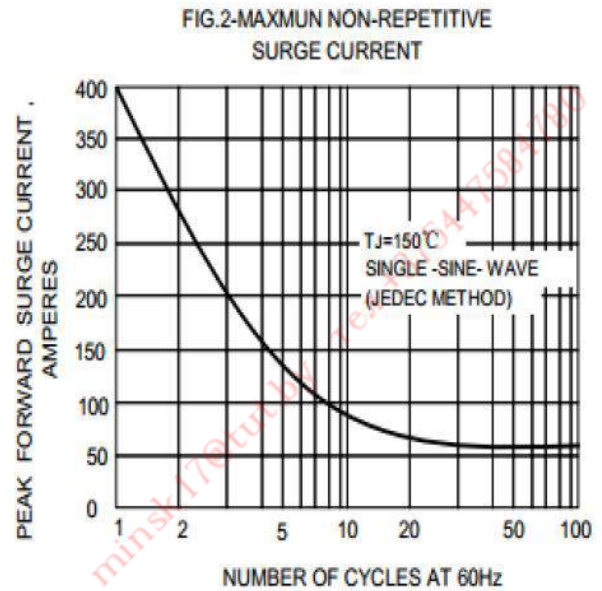
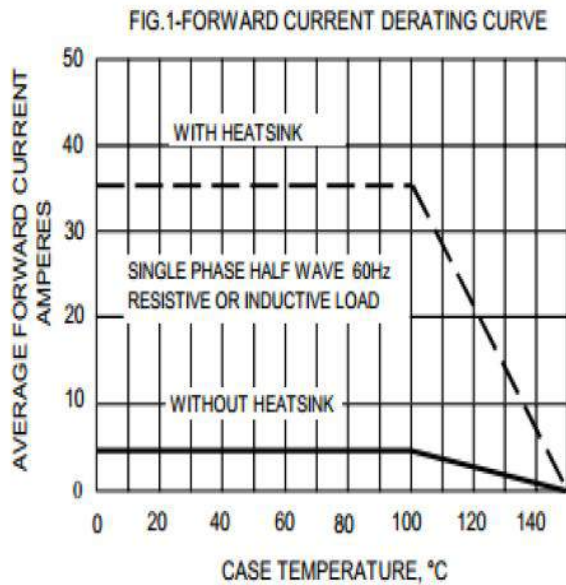

Note: Specifications are subject to change without notice. For more detail and update, please visit our website.

KBPC6005 THRU KBPC610

SINGLE-PHASE BRIDGE RECTIFIER

REVERSE VOLTAGE 50 to 1000 Volts FORWARD CURRENT 6.0 Ampere

FEATURES

- ◆ High Current Capability
- ◆ High Case Dielectric Strength
- ◆ High Surge Current Capability
- ◆ Ideal for Printed Circuit Board Application
- ◆ Plastic Material has Underwriters Laboratory

Flammability Classification 94V-O

Mechanical Data

- ◆ Case: Molded Plastic
- ◆ Terminals: Plated Leads Solderable per MIL-STD-202, Method 208
- ◆ Polarity: Marked on Body
- ◆ Weight: 3.8 grams (approx.)
- ◆ Mounting Position: Through Hole for #6 Screw
- ◆ Mounting Torque: 5.0 Inch-pounds Maximum
- ◆ Marking: Type Number

BR-6

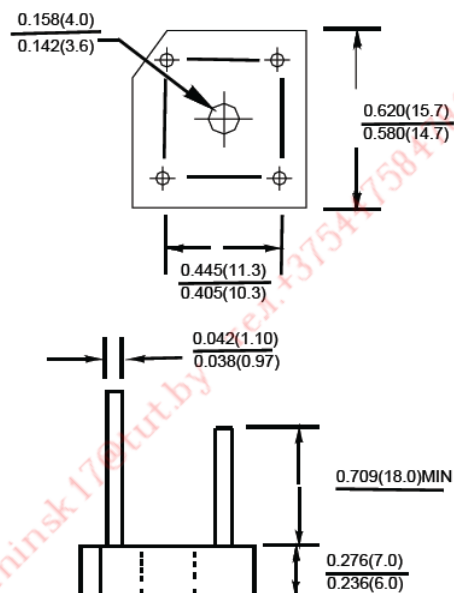

Dimensions in inches and (millimeters)

MAXIMUM RATINGS AND ELECTRICAL CHARACTERISTICS

Rating at 25°C ambient temperature unless otherwise specified.

Single phase, half wave, 60Hz, resistive or inductive load. For capacitive load, derate current by 20%

PARAMETER	SYMBOL	KBPC 6005	KBPC 601	KBPC 602	KBPC 604	KBPC 606	KBPC 608	KBPC 610	UNIT
Peak Repetitive Reverse Voltage	V_{RRM}								V
Working Peak Reverse Voltage	V_{RRM}	50	100	200	400	600	800	1000	V
DC Blocking Voltage	V_R								V
RMS Reverse Voltage	$V_{R(RMS)}$	35	70	140	280	420	560	700	V
Average Rectified Output Current (Note 1) @TC = 50°C	I_O					60			A
Non-Repetitive Peak Forward Surge Current 8.3ms Single half sine-wave superimposed on rated load (JEDEC Method)	I_{FSM}					125			A
Forward Voltage (per element) @ $I_F = 3.0A$	V_{FM}					1.0V			
Peak Reverse Current @TC = 25°C	I_R					5			μA
At Rated DC Blocking Voltage @TC = 100°C	I_R					0.5			mA
I ² t Rating for fusing (t < 8.3ms) (Note 2)	I ² t					64			A ² S
Typical Junction Capacitance (Note 3)	C_J					55			pF
Typical Thermal Resistance (Note 4)	$R_{\theta JC}$					12.5			K/W
Operating and Storage Temperature Range	T_J, T_{STG}					-65 to +125			°C

Note: 1. Measured at 1.0MHz and applied reverse voltage of 4.0V DC. 2. Device mounted on 75mm x 75mm x 1.6mm Cu Plate Heatsink.

3. Mounted on metal chassis. 4. Non-repetitive, for t > 1ms and < 8.3ms.

KBPC6005 THRU KBPC610

SINGLE-PHASE BRIDGE RECTIFIER

REVERSE VOLTAGE 50 to 1000 Volts FORWARD CURRENT 6.0 Ampere

RATING AND CHARACTERISTIC CURVES KBPC6005 THRU KBPC610

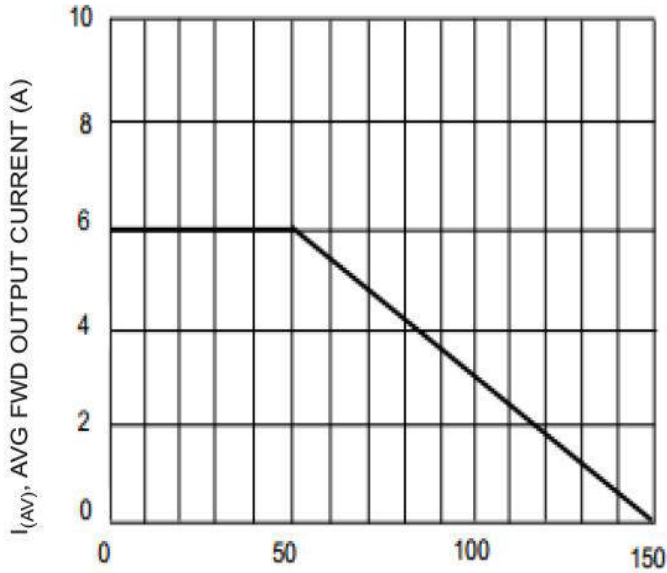

T_C , CASE TEMPERATURE (°C)
Fig. 1 Forward Current Derating Curve

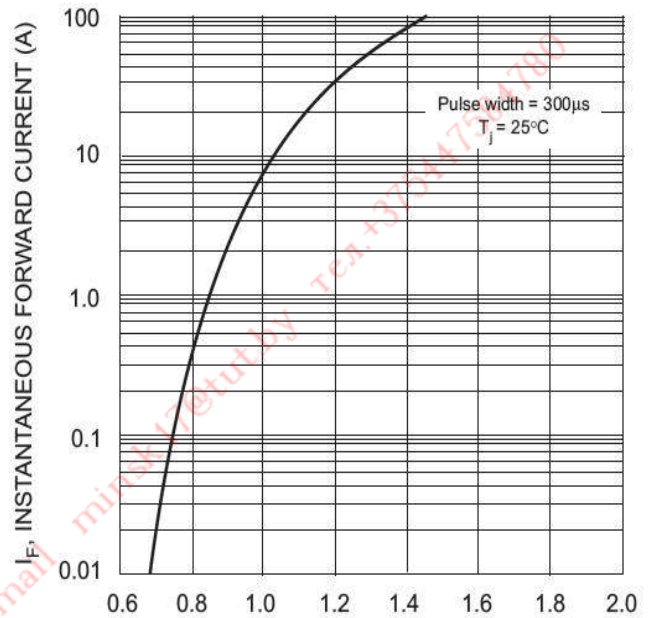

V_F , INSTANTANEOUS FORWARD VOLTAGE (V)
Fig. 2 Typical Forward Characteristics, per element

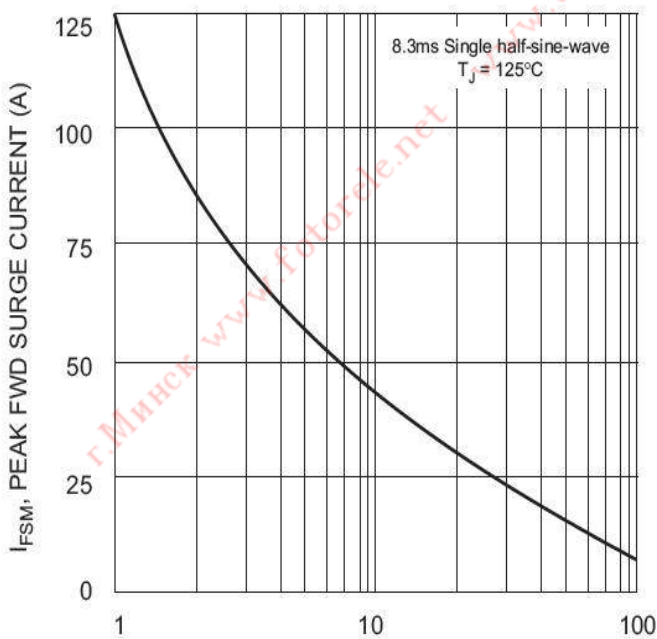

NUMBER OF CYCLES AT 60Hz
Fig. 3 Peak Forward Surge Current

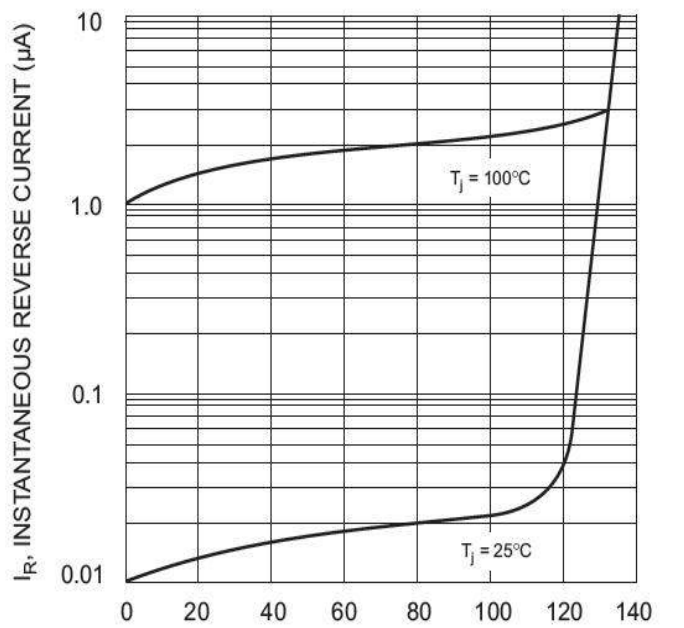

PERCENT OF RATED PEAK REVERSE VOLTAGE (%)
Fig. 4 Typical Reverse Characteristics

Note: Specifications are subject to change without notice. For more detail and update, please visit our website.

KBPC8005 THRU KBPC810

SINGLE-PHASE BRIDGE RECTIFIER

REVERSE VOLTAGE 50 to 1000 Volts FORWARD CURRENT 8.0 Ampere

FEATURES

- ◆ High forward surge current capability
- ◆ Ideal for printed circuit board
- ◆ High isolation voltage from case to leads
- ◆ High temperature soldering guaranteed:
260°C /10 second, at 5 lbs. (2.3kg) tension.

Mechanical Data

- ◆ Case: Molded plastic body
- ◆ Terminal: Lead solderable per MIL-STD-202E method 208C
- ◆ Polarity: Polarity symbols molded on case
- ◆ Mounting: Thru hole for #6 screw, 5.0 in.-lbs torque max
- ◆ Weight: 0.20ounce, 5.62 grams

BR-8

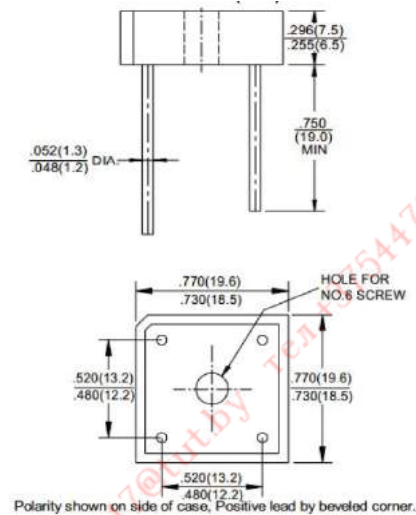

MAXIMUM RATINGS AND ELECTRICAL CHARACTERISTICS

Rating at 25°C ambient temperature unless otherwise specified.

Single phase, half wave, 60Hz, resistive or inductive load. For capacitive load, derate current by 20%

PARAMETER	SYMBOL	KBPC 8005	KBPC 801	KBPC 802	KBPC 804	KBPC 806	KBPC 808	KBPC 810	UNIT	
Maximum Repetitive Peak Reverse Voltage	V_{RRM}	50	100	200	400	600	800	1000	Volts	
Maximum RMS Voltage	V_{RRM}	35	70	140	280	420	560	700	Volts	
Maximum DC Blocking Voltage	V_{DC}	50	100	200	400	600	800	1000	Volts	
Maximum Average Forward Rectified Output Current at TC=100°C	$I_{(AV)}$	8.0							Amps	
Non-Repetitive Peak Forward Surge Current 8.3ms Single half sine-wave superimposed on rated load (JEDEC Method)	I_{FSM}	175							Amps	
Rating for Fusing (t<8.3ms)	I^2t	64							A ² S	
Maximum Instantaneous Forward Voltage at 4.0A	V_F	1.0							Volts	
Maximum DC Reverse Current at rated DC blocking voltage	I_R	$T_A=25^\circ\text{C}$	5.0							μAmps
		$T_A=125^\circ\text{C}$	1.0							mAmps
Isolation Voltage from case to leads	V_{ISO}	2500							V_{AC}	
Typical Thermal Resistance (Note 1)	$R_{\theta JC}$	6.0							°C/W	
Operating Temperature Range	T_j	-55 to +150							°C	
Storage Temperature Range	T_{STG}	-55 to +150							°C	

Note: 1. Unit mounted on 8.7" × 8.7" × 0.24" thick (22 × 22 × 0.6 cm) Al. plate.

KBPC8005 THRU KBPC810

SINGLE-PHASE BRIDGE RECTIFIER

REVERSE VOLTAGE 50 to 1000 Volts FORWARD CURRENT 8.0 Ampere

RATING AND CHARACTERISTIC CURVES KBPC8005 THRU KBPC810

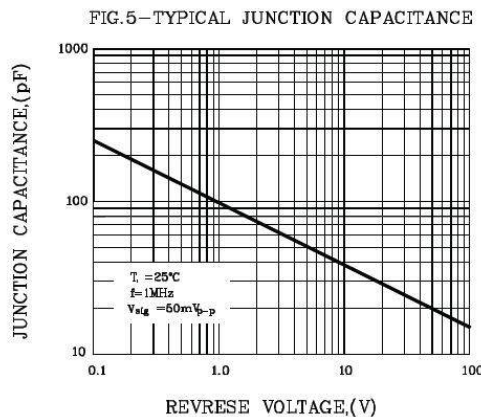
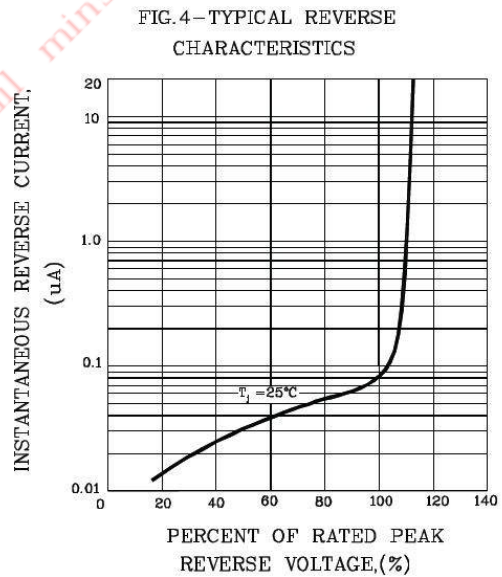
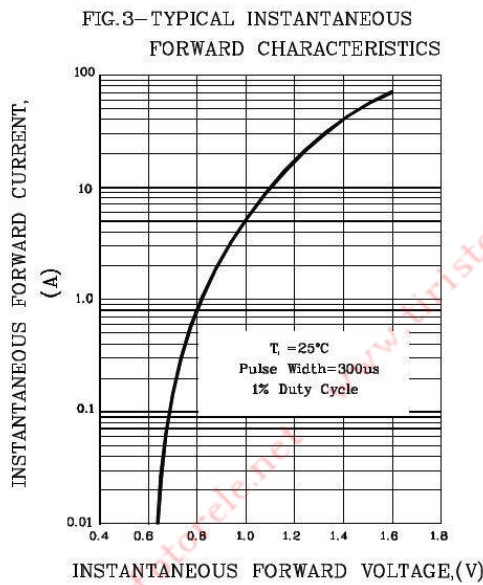
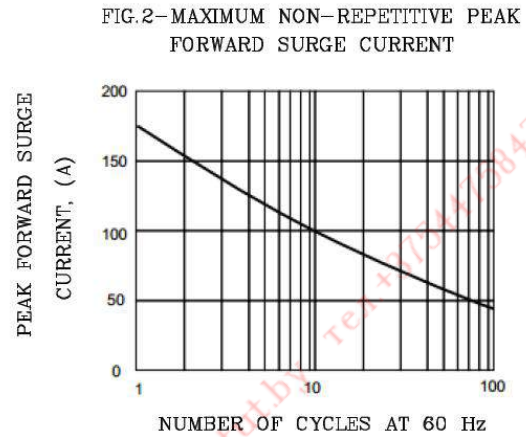
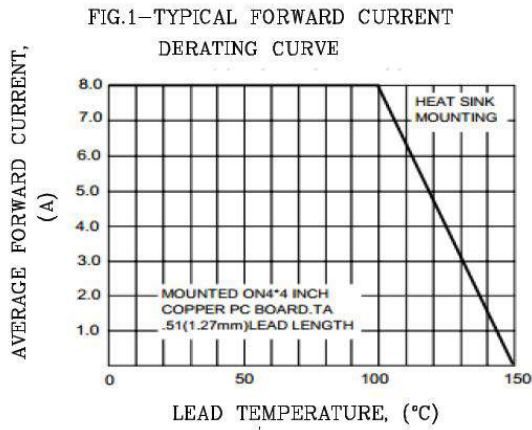

Note: Specifications are subject to change without notice. For more detail and update, please visit our website.

KBPC10005 THRU KBPC1010

SINGLE-PHASE BRIDGE RECTIFIER

REVERSE VOLTAGE 50 to 1000 Volts FORWARD CURRENT 10.0 Ampere

FEATURES

- ◆ Rating to 1000V PRV
- ◆ Surge overload rating to 175 Amperes peak
- ◆ Ideal for printed circuit board
- ◆ Reliable low cost construction utilizing molded plastic technique results in inexpensive product
- ◆ Lead solderable per MIL-STD-202 method 208
- ◆ Mounting: thru hole for # 6 screw Mounting

BR-8

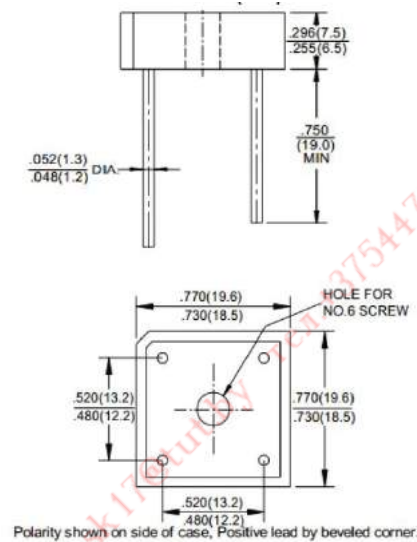

Dimensions in inches and (millimeters)

MAXIMUM RATINGS AND ELECTRICAL CHARACTERISTICS

Rating at 25°C ambient temperature unless otherwise specified.

Single phase, half wave, 60Hz, resistive or inductive load. For capacitive load, derate current by 20%

PARAMETER	SYMBOL	KBPC 10005	KBPC 1001	KBPC 1002	KBPC 1004	KBPC 1006	KBPC 1008	KBPC 1010	UNIT
Maximum Repetitive Peak Reverse Voltage	V_{RRM}	50	100	200	400	600	800	1000	v
Maximum RMS Voltage	V_{RRM}	35	70	140	280	420	560	700	v
Maximum DC Blocking Voltage	V_{DC}	50	100	200	400	600	800	1000	v
Maximum Average Forward And Output Current @ $T_A=50^\circ\text{C}$	$I_{F(AV)}$	10.0							A
Non-Repetitive Peak Forward Surge Current 8.3ms Single half sine-wave superimposed on rated load	I_{FSM}	175.0							A
Maximum instantaneous forward voltage at 5.0 A	V_F	1.0							V
Maximum Reverse Current @ $T_A=25^\circ\text{C}$ at rated DC blocking voltage @ $T_A=125^\circ\text{C}$	I_R	5.0 0.5							μA mA
Operating junction temperature range	T_J	-55 to +125							°C
Storage Temperature Range	T_{STG}	-55 to +150							°C

Note: 1. Unit mounted on 8.7"×8.7"×0.24" thick (22×22×0.6 cm) Al. plate.

2. Unit mounted on P.C.B at 0.375" (9.5mm) lead length with 0.47"×0.47" (12×12mm) copper pads.

KBPC1005 THRU KBPC1010

SINGLE-PHASE BRIDGE RECTIFIER

REVERSE VOLTAGE 50 to 1000 Volts FORWARD CURRENT 10.0 Ampere

RATING AND CHARACTERISTIC CURVES KBPC1005 THRU KBPC1010

FIG.1 -- PEAK FORWARD SURGE CURRENT

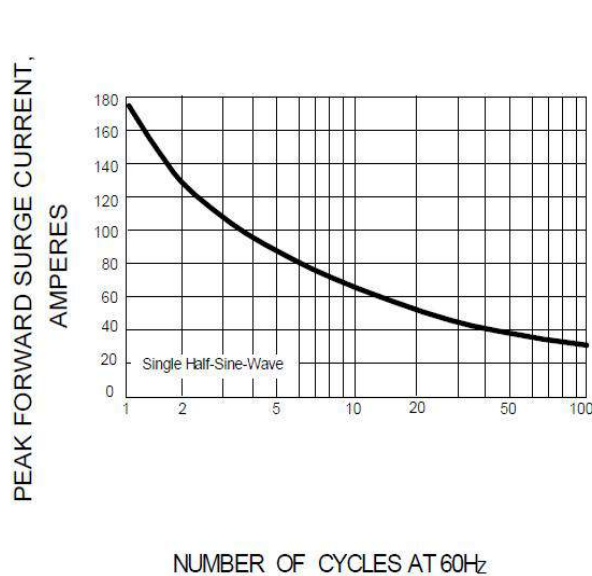

FIG.2 -- FORWARD DERATING CURVE

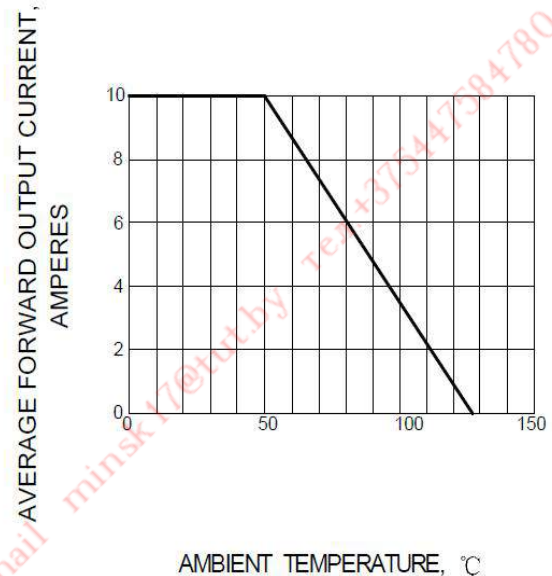

FIG.3 -- TYPICAL FORWARD CHARACTERISTIC

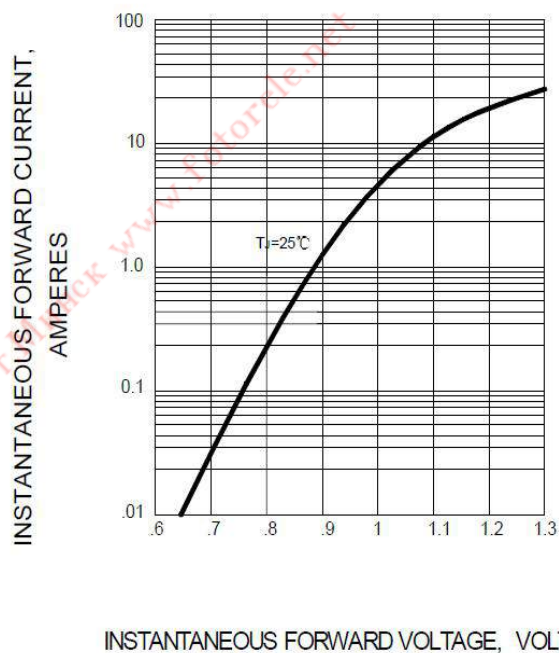
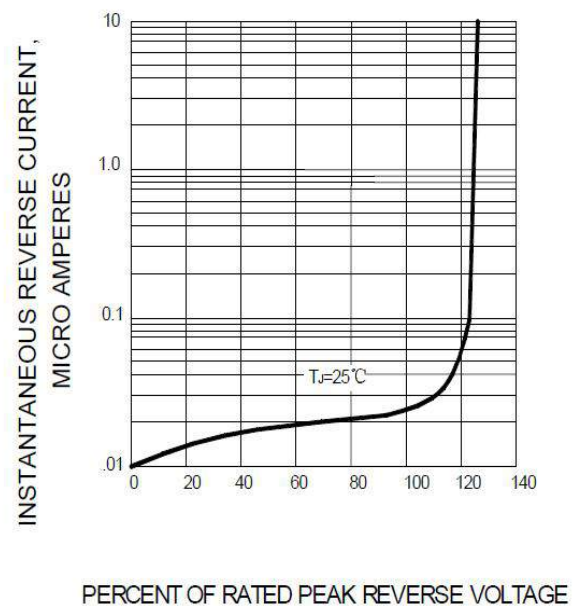

FIG.4 -- TYPICAL REVERSE CHARACTERISTIC



Note: Specifications are subject to change without notice. For more detail and update, please visit our website.

KBPC15005 THRU KBPC1510

SINGLE-PHASE BRIDGE RECTIFIER

REVERSE VOLTAGE 50 to 1000 Volts FORWARD CURRENT 15.0 Ampere

FEATURES

- ◆ High overload surge current capability
- ◆ Low thermal resistance
- ◆ High isolation voltage from case to lugs
- ◆ High temperature soldering guaranteed:
260°C /10 second, at 5 lbs. (2.3kg) tension

Mechanical Data

- ◆ Case: Metal case
- ◆ Terminal: Plated 0.25" (6.35mm) lug
- ◆ Polarity: Polarity symbols marked on case
- ◆ Mounting: Thru hole for #10 screw, 20 in.- lbs. Torque Max
- ◆ Weight: 1.02 ounce, 29 gram

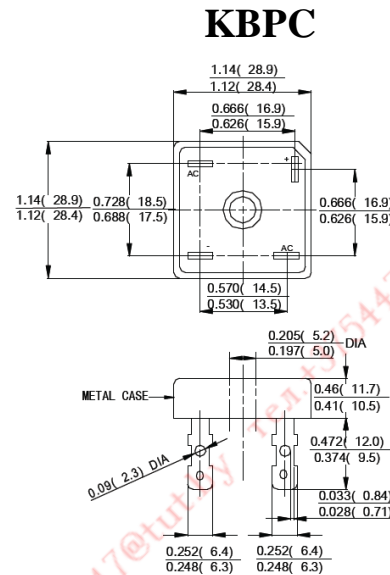

Dimensions in inches and (millimeters)

MAXIMUM RATINGS AND ELECTRICAL CHARACTERISTICS

Rating at 25°C ambient temperature unless otherwise specified.

Single phase, half wave, 60Hz, resistive or inductive load. For capacitive load, derate current by 20%

PARAMETER	SYMBOL	KBPC 15005	KBPC 1501	KBPC 1502	KBPC 1504	KBPC 1506	KBPC 1508	KBPC 1510	UNIT
Maximum Repetitive Peak Reverse Voltage	V_{RRM}	50	100	200	400	600	800	1000	Volts
Maximum RMS Voltage	V_{RRM}	35	70	140	280	420	560	700	Volts
Maximum DC Blocking Voltage	V_{DC}	50	100	200	400	600	800	1000	Volts
Maximum Average Forward Rectified Output Current, at $T_C=50^\circ C$ (Note 1,2)	$I_{(VA)}$	15							Amps
Peak Forward Surge Current 8.3ms Single half sine-wave superimposed on rated load (JEDEC Method)	I_{FSM}	300							Amps
Rating for Fusing ($t < 8.3ms$)	I^2t	373							A^2S
Maximum Instantaneous Forward Voltage at 7.5A	V_F	1.1							Volts
Maximum DC Reverse Current at rated DC blocking voltage	$T_A=25^\circ C$	I_R 5.0							μA mps
	$T_A=125^\circ C$	0.5							mAmps
Isolation Voltage from case to lugs	V_{ISO}	2500							V_{AC}
Typical Thermal Resistance (Note 1,2)	$R_{\theta JC}$	2.0							$^\circ C/W$
Operating Temperature Range	T_j	-65 to +150							$^\circ C$
Storage Temperature Range	T_{STG}	-65 to +150							$^\circ C$

Note: 1. Unit mounted on 9"×3.5"×4.6" (23×9×11.8mm) Al. finned plate.

2. Bolt down on heat-sink with silicone thermal compound between bridge and mounting surface for maximum heat transfer efficiency with #10 screw.

KBPC15005 THRU KBPC1510

SINGLE-PHASE BRIDGE RECTIFIER

REVERSE VOLTAGE 50 to 1000 Volts FORWARD CURRENT 15.0 Ampere

RATING AND CHARACTERISTIC CURVES KBPC15005 THRU KBPC1510

FIG.1-DERATING CURVE FOR OUTPUT RECTIFIED CURRENT

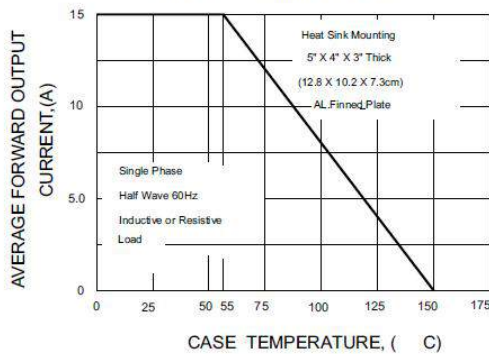

FIG.2-MAXIMUM NON-REPETITIVE PEAK FORWARD SURGE CURRENT PER ELEMENT

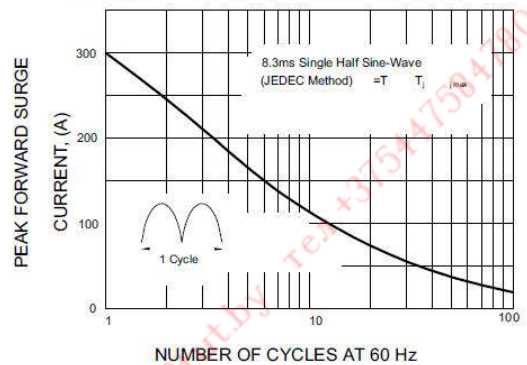

FIG.3-TYPICAL FORWARD CHARACTERISTICS PER BRIDGE ELEMENT

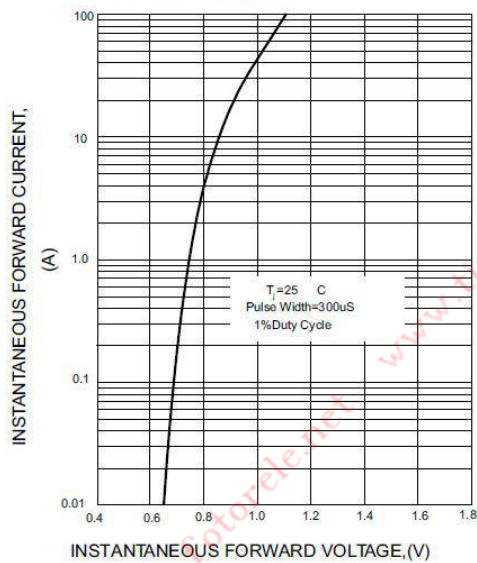

FIG.4-TYPICAL REVERSE CHARACTERISTICS PER BRIDGE ELEMENT

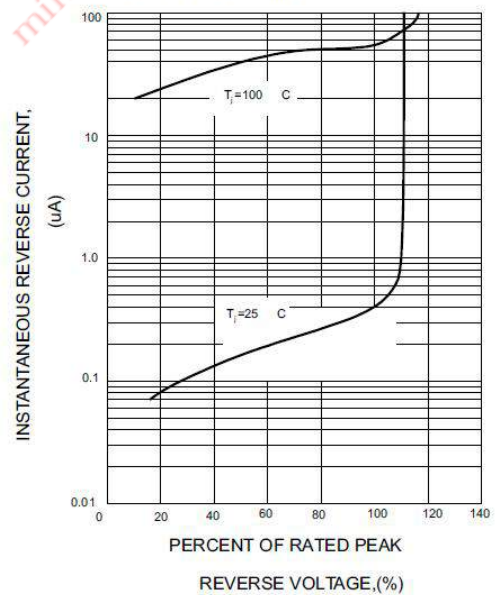

FIG.5-TYPICAL JUNCTION CAPACITANCE PER BRIDGE ELEMENT

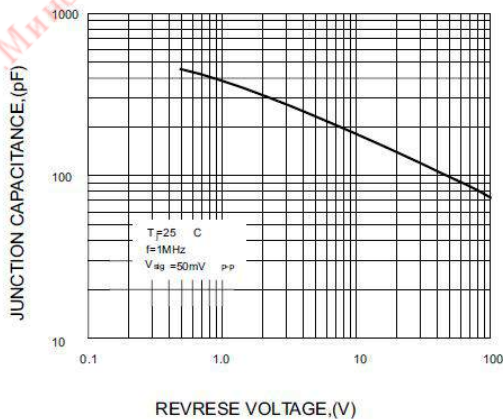
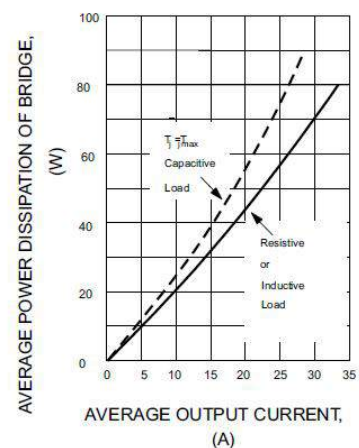

FIG.6-MAXIMUM POWER DISSIPATION



Note: Specifications are subject to change without notice. For more detail and update, please visit our website.

KBPC25005 THRU KBPC2510

SINGLE-PHASE BRIDGE RECTIFIER

VOLTAGE RANGE 50 to 1000 Volts CURRENT 25.0 Ampere

FEATURES

- ◆ High forward surge current capability.
- ◆ Low thermal resistance.
- ◆ High isolation voltage from case to lugs.
- ◆ High temperature soldering guaranteed:
260°C/10 second, at 5 lbs. (2.3kg) tension.

Mechanical Data

- ◆ Case: Metal case.
- ◆ Terminal: Plated 0.25" (6.35mm) lug.
- ◆ Polarity: Polarity symbols marked on case.
- ◆ Mounting: Thru hole for #10 screw, 20 in.- lbs. Torque Max.
- ◆ Weight: 1.02 ounce, 29gram.

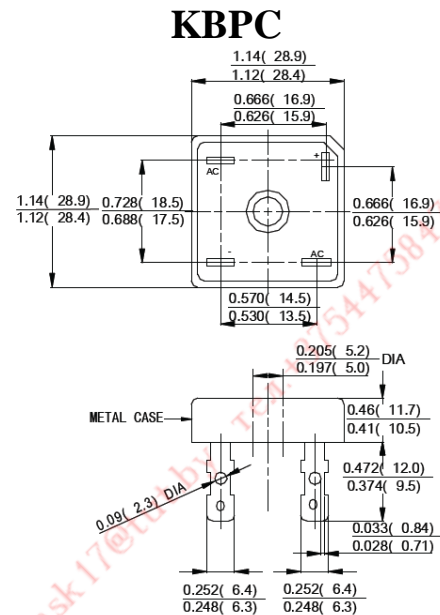

Dimensions in inches and (millimeters)

MAXIMUM RATINGS AND ELECTRICAL CHARACTERISTICS

Rating at 25°C ambient temperature unless otherwise specified.

Single phase, half wave, 60Hz, resistive or inductive load. For capacitive load, derate current by 20%

PARAMETER	SYMBOL	KBPC 25005	KBPC 2501	KBPC 2502	KBPC 2504	KBPC 2506	KBPC 2508	KBPC 2510	UNIT	
Maximum Repetitive Peak Reverse Voltage	V_{RRM}	50	100	200	400	600	800	1000	Volts	
Maximum RMS Voltage	V_{RMS}	35	70	140	280	420	560	700	Volts	
Maximum DC Blocking Voltage	V_{DC}	50	100	200	400	600	800	1000	Volts	
Maximum Average Forward Rectified Output Current at $T_C=50^\circ\text{C}$ (Note 1,2)	$I_{(AV)}$	25							Amps	
Peak Forward Surge Current 8.3ms single half sine-wave superimposed on rated load (JEDEC Method)	I_{FSM}	300							Amps	
Rating for Fusing ($t < 8.3\text{ms}$)	I^2t	373							A^2s	
Maximum Instantaneous Forward Voltage at 12.5A	V_F	1.1							Volts	
Maximum Reverse Current at Rated DC Blocking Voltage	I_R	$T_A=25^\circ\text{C}$	5.0							μAmps
		$T_A=125^\circ\text{C}$	0.5							mAmps
Isolation Voltage from case to lugs	V_{ISO}	2500							V_{AC}	
Typical Thermal Resistance (Note 1,2)	$R_{\theta JL}$	2.0							$^\circ\text{C}/\text{W}$	
Operating Temperature Range	T_J	-65 to +150							$^\circ\text{C}$	
Storage Temperature Range	T_{stg}	-65 to +150							$^\circ\text{C}$	

Note: 1. Unit mounted on 9" x 3.5" x 4.6" thick (23 x 9 x 11.8mm) Al. Plate.

2. Bolt down on heat-sink with silicone thermal compound between bridge and mounting surface for maximum heat transfer efficiency with #10 screw.

KBPC25005 THRU KBPC2510

SINGLE-PHASE BRIDGE RECTIFIER

VOLTAGE RANGE 50 to 1000 Volts CURRENT 25.0 Ampere

RATING AND CHARACTERISTIC CURVES KBPC25005 THRU KBPC2510

FIG.1-DERATING CURVE FOR
OUTPUT RECTIFIED CURRENT

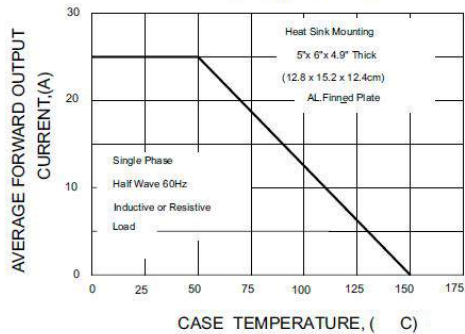

FIG.2-MAXIMUM NON-REPETITIVE PEAK
FORWARD SURGE CURRENT PER ELEMENT

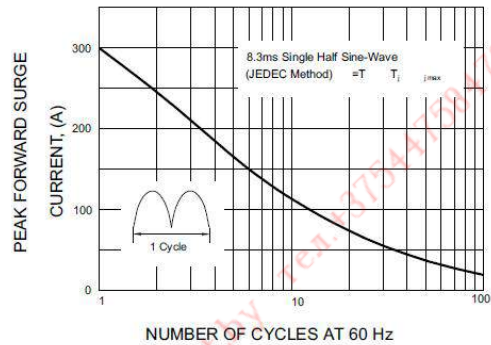

FIG.3-TYPICAL FORWARD CHARACTERISTICS
PER BRIDGE ELEMENT

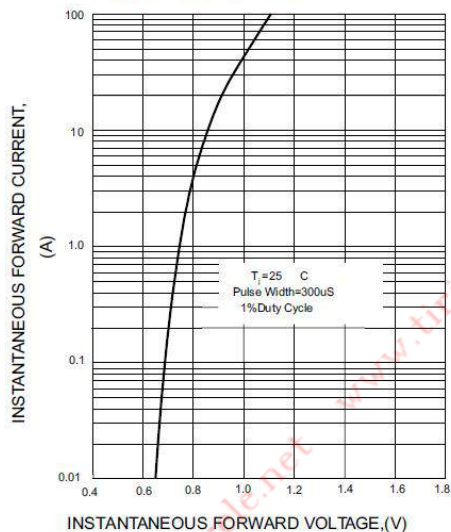

FIG.4-TYPICAL REVERSE CHARACTERISTICS
PER BRIDGE ELEMENT

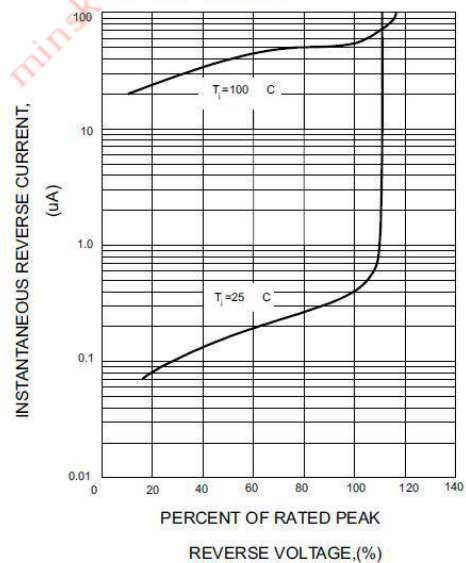

FIG.5-TYPICAL JUNCTION CAPACITANCE
PER BRIDGE ELEMENT

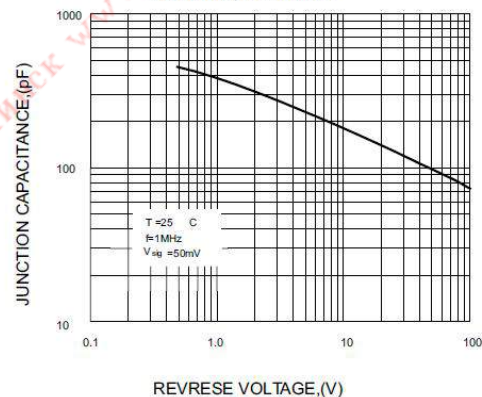
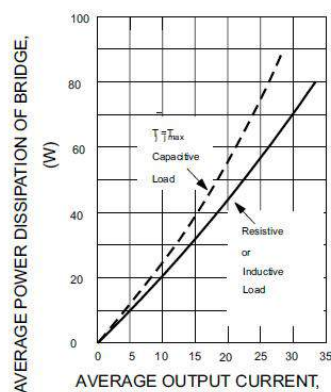

FIG.6-MAXIMUM POWER DISSIPATION



Note: Specifications are subject to change without notice. For more detail and update, please visit our website.

KBPC35005 THRU KBPC3510

SINGLE-PHASE BRIDGE RECTIFIER

VOLTAGE RANGE 50 to 1000 Volts CURRENT 35.0 Ampere

FEATURES

- ◆ High forward surge current capability.
- ◆ Integrally molded heatsink provide very low thermal resistance.
- ◆ High isolation voltage from case to lugs.
- ◆ High temperature soldering guaranteed: 260°C/10 second, at 5 lbs. (2.3kg) tension.

Mechanical Data

- ◆ Case: Metal case.
- ◆ Terminal: Plated 0.25" (6.35mm) lug.
- ◆ Polarity: Polarity symbols marked on case.
- ◆ Mounting: Thru hole for #10 screw, 20 in.- lbs. Torque Max.
- ◆ Weight: 1.02 ounce, 29gram.

KBPC

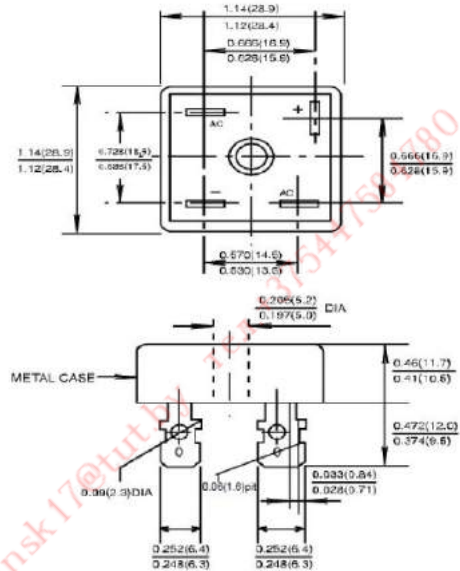

Dimensions in inches and (millimeters)

MAXIMUM RATINGS AND ELECTRICAL CHARACTERISTICS

Rating at 25°C ambient temperature unless otherwise specified.

Single phase, half wave, 60Hz, resistive or inductive load. For capacitive load, derate current by 20%

PARAMETER	SYMBOL	KBPC 35005	KBPC 3501	KBPC 3502	KBPC 3504	KBPC 3506	KBPC 3508	KBPC 3510	UNIT	
Maximum Repetitive Peak Reverse Voltage	V_{RRM}	50	100	200	400	600	800	1000	Volts	
Maximum RMS Voltage	V_{RMS}	35	70	140	280	420	560	700	Volts	
Maximum DC Blocking Voltage	V_{DC}	50	100	200	400	600	800	1000	Volts	
Maximum Average Forward Rectified Output Current at $T_C=50^\circ\text{C}$ (Note 1,2)	$I_{(AV)}$	35							Amps	
Peak Forward Surge Current 8.3ms single half sine-wave superimposed on rated load (JEDEC Method)	I_{FSM}	400							Amps	
Rating for Fusing ($t < 8.3\text{ms}$)	I^2t	664							A^2s	
Maximum Instantaneous Forward Voltage at 17.5A	V_F	1.1							Volts	
Maximum Reverse Current at Rated DC Blocking Voltage	$T_A=25^\circ\text{C}$	I_R	5.0							μAmps
	$T_A=125^\circ\text{C}$		0.5							mAmps
Isolation Voltage from case to lugs	V_{ISO}	2500							V_{AC}	
Typical Thermal Resistance (Note 1,2)	$R_{\theta JL}$	2.0							$^\circ\text{C}/\text{W}$	
Operating Temperature Range	T_J	-65 to +150							$^\circ\text{C}$	
Storage Temperature Range	T_{stg}	-65 to +150							$^\circ\text{C}$	

Note: 1. Unit mounted on 9" x 3.5" x 4.6" thick (23 x 9 x 11.8mm) Al. plate.

2. Bolt down on heat-sink with silicone thermal compound between bridge and mounting surface for maximum heat transfer efficiency with #10 screw.

KBPC35005 THRU KBPC3510

SINGLE-PHASE BRIDGE RECTIFIER

VOLTAGE RANGE 50 to 1000 Volts CURRENT 35.0 Ampere

RATING AND CHARACTERISTIC CURVES KBPC35005 THRU KBPC3510

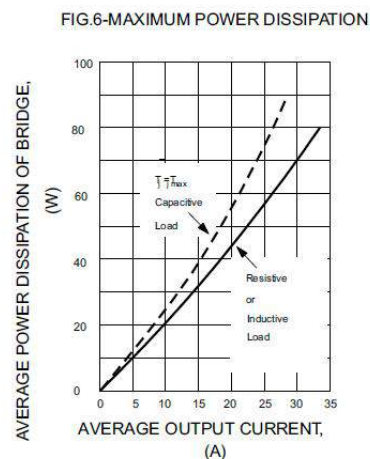
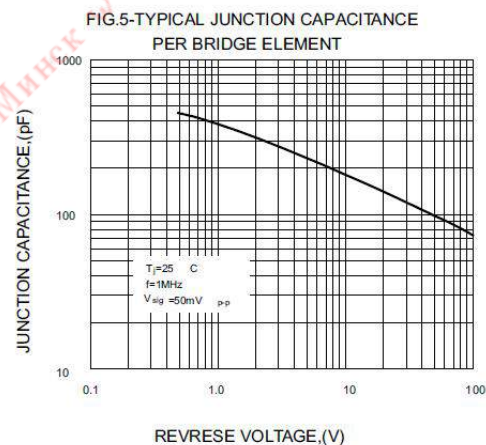
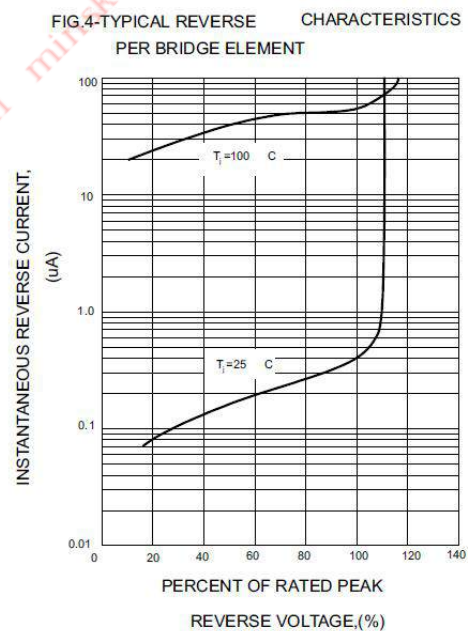
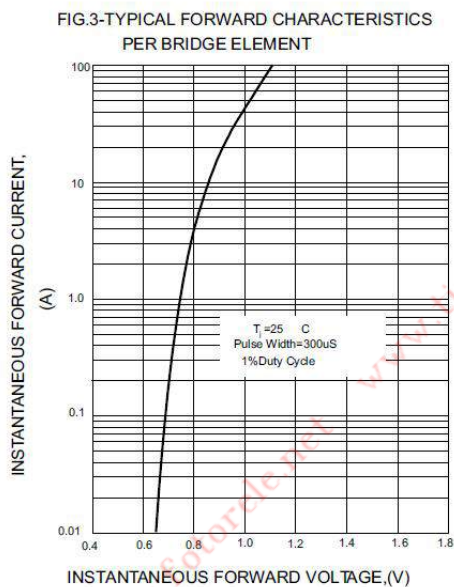
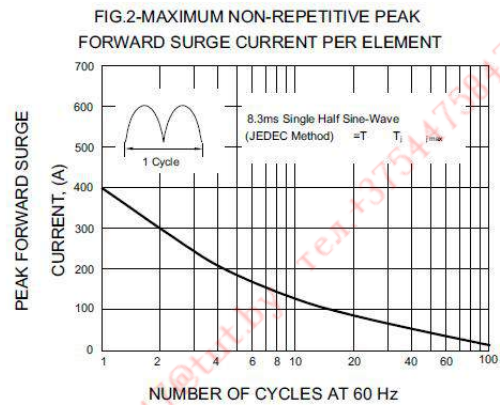
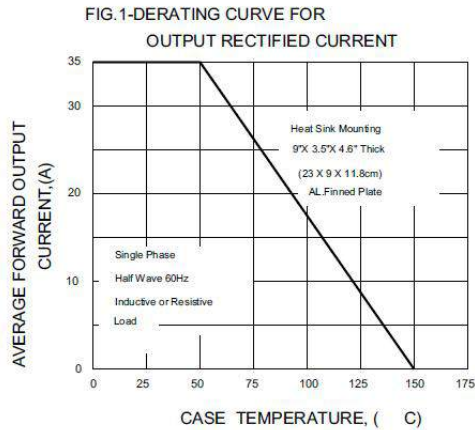

Note: Specifications are subject to change without notice. For more detail and update, please visit our website.

KBPC50005 THRU KBPC5010

SINGLE-PHASE BRIDGE RECTIFIER

REVERSE VOLTAGE 50 to 1000 Volts FORWARD CURRENT 50.0 Ampere

FEATURES

- ◆ High forward surge current capability
- ◆ Integrally molded heatsink provide very low thermal resistance
- ◆ High isolation voltage from case to lugs
- ◆ High temperature soldering guaranteed: 260°C /10 second, at 5 lbs. (2.3kg) tension

Mechanical Data

- ◆ Case: Metal case
- ◆ Terminal: Plated 0.25" (6.35mm) lug
- ◆ Polarity: Polarity symbols marked on case
- ◆ Mounting: Thru hole for #10 screw, 20 in.- lbs. Torque Max
- ◆ Weight: 1.02 ounce, 29 gram

KBPC

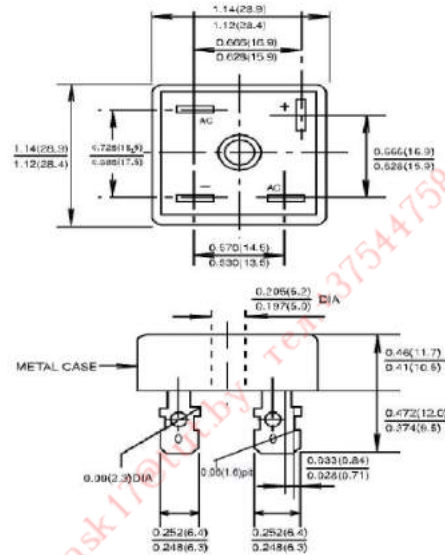

Dimensions in inches and (millimeters)

MAXIMUM RATINGS AND ELECTRICAL CHARACTERISTICS

Rating at 25°C ambient temperature unless otherwise specified.

Single phase, half wave, 60Hz, resistive or inductive load. For capacitive load, derate current by 20%

PARAMETER	SYMBOL	KBPC 50005	KBPC 5001	KBPC 5002	KBPC 5004	KBPC 5006	KBPC 5008	KBPC 5010	UNIT
Maximum Repetitive Peak Reverse Voltage	V_{RRM}	50	100	200	400	600	800	1000	Volts
Maximum RMS Voltage	V_{RRM}	35	70	140	280	420	560	700	Volts
Maximum DC Blocking Voltage	V_{DC}	50	100	200	400	600	800	1000	Volts
Maximum Average Forward Rectified Output Current, at $T_C=50^\circ\text{C}$ (Note 1,2)	$I_{(AV)}$	50							Amps
Peak Forward Surge Current 8.3ms Single half sine-wave superimposed on rated load (JEDEC Method)	I_{FSM}	400							Amps
Rating for Fusing ($t < 8.3\text{ms}$)	I^2t	664							A^2S
Maximum Instantaneous Forward Voltage at 25A	V_F	1.1							Volts
Maximum DC Reverse Current at rated DC blocking voltage	$T_A=25^\circ\text{C}$	I_R 5.0							μAmps
	$T_A=125^\circ\text{C}$	1.0							mAmps
Isolation Voltage from case to lugs	V_{ISO}	2500							V_{AC}
Typical Thermal Resistance (Note 1,2)	$R_{\theta JC}$	2.0							$^\circ\text{C}/\text{W}$
Operating Temperature Range	T_J	-65 to +150							$^\circ\text{C}$
Storage Temperature Range	T_{STG}	-65 to +150							$^\circ\text{C}$

Note: 1. Unit mounted on 9"×3.5"×4.6" (23×9×11.8mm) Al. finned plate.

2. Bolt down on heat-sink with silicone thermal compound between bridge and mounting surface for maximum heat transfer efficiency with #10 screw.

KBPC50005 THRU KBPC5010

SINGLE-PHASE BRIDGE RECTIFIER

REVERSE VOLTAGE 50 to 1000 Volts FORWARD CURRENT 50.0 Ampere

RATING AND CHARACTERISTIC CURVES KBPC50005 THRU KBPC5010

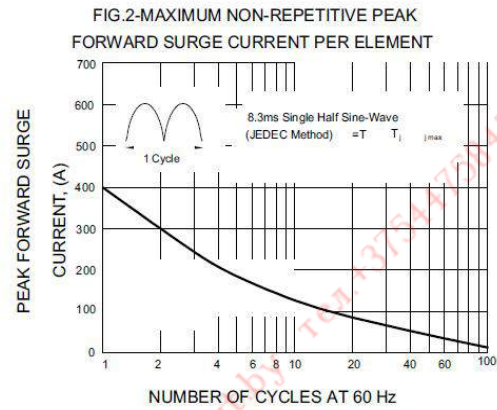
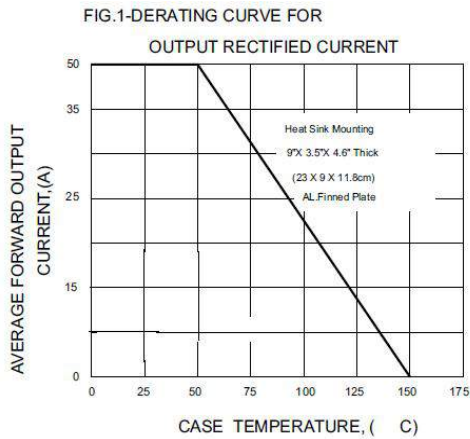

FIG.3-TYPICAL FORWARD CHARACTERISTICS PER BRIDGE ELEMENT

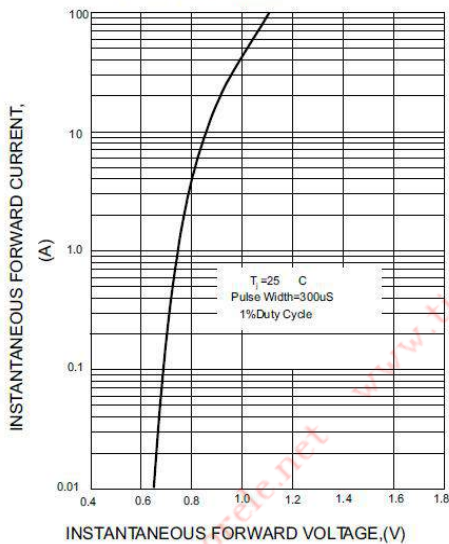

FIG.4-TYPICAL REVERSE CHARACTERISTICS PER BRIDGE ELEMENT

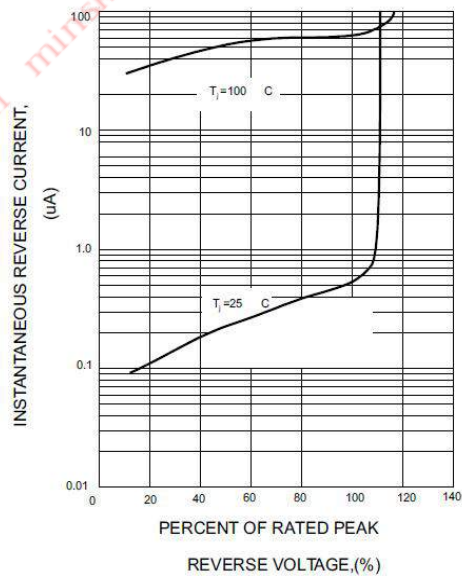
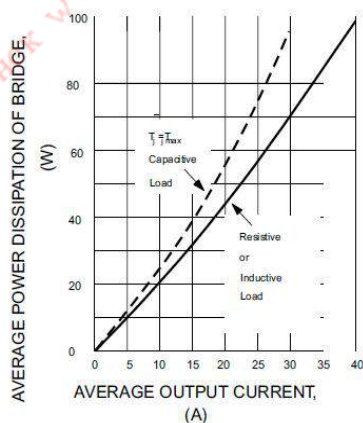

FIG.5-MAXIMUM POWER DISSIPATION



Note: Specifications are subject to change without notice. For more detail and update, please visit our website.

KBPC25005W THRU KBPC2510W

SINGLE-PHASE BRIDGE RECTIFIER

VOLTAGE RANGE 50 to 1000 Volts CURRENT 25.0 Ampere

FEATURES

- ◆ High forward surge current capability.
- ◆ Low thermal resistance.
- ◆ High isolation voltage from case to lugs.
- ◆ High temperature soldering guaranteed:
260°C/10 second, at 5 lbs. (2.3kg) tension.

Mechanical Data

- ◆ Case: Metal case.
- ◆ Terminal: Plated 0.25" (6.35mm) lug.
- ◆ Polarity: Polarity symbols marked on case.
- ◆ Mounting: Thru hole for #10 screw, 20 in.- lbs. Torque Max.
- ◆ Weight: 1.02 ounce, 29gram.

KBPC-W

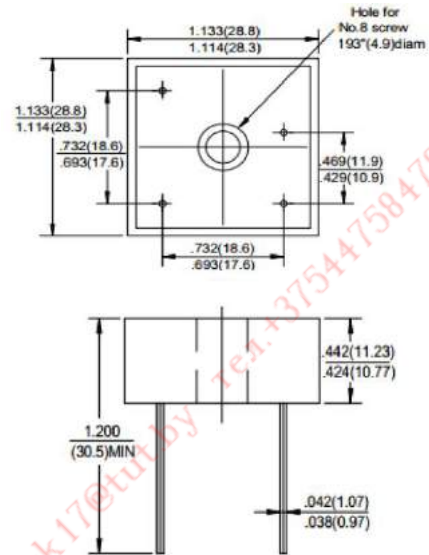

Dimensions in inches and (millimeters)

MAXIMUM RATINGS AND ELECTRICAL CHARACTERISTICS

Rating at 25°C ambient temperature unless otherwise specified.

Single phase, half wave, 60Hz, resistive or inductive load. For capacitive load, derate current by 20%

PARAMETER	SYMBOL	KBPC 25005W	KBPC 2501W	KBPC 2502W	KBPC 2504W	KBPC 2506W	KBPC 2508W	KBPC 2510W	UNIT
Maximum Repetitive Peak Reverse Voltage	V_{RRM}	50	100	200	400	600	800	1000	Volts
Maximum RMS Voltage	V_{RMS}	35	70	140	280	420	560	700	Volts
Maximum DC Blocking Voltage	V_{DC}	50	100	200	400	600	800	1000	Volts
Maximum Average Forward Rectified Output Current at $T_C=50^\circ\text{C}$ (Note 1, 2)	$I_{(AV)}$	25							Amps
Peak Forward Surge Current 8.3ms single half sine-wave superimposed on rated load (JEDEC Method)	I_{FSM}	300							Amps
Rating for Fusing ($t < 8.3\text{ms}$)	I_{ET}	373							A^2s
Maximum Instantaneous Forward Voltage at 12.5A	V_F	1.1							Volts
Maximum Reverse Current at Rated DC Blocking Voltage	I_R	$T_A=25^\circ\text{C}$							μAmps
		$T_A=125^\circ\text{C}$							mAmps
Isolation Voltage from case to lugs	V_{ISO}	2500							V_{AC}
Typical Thermal Resistance (Note 1,2)	$R_{\theta JL}$	2.0							$^\circ\text{C}/\text{W}$
Operating Temperature Range	T_J	-65 to +150							$^\circ\text{C}$
Storage Temperature Range	T_{stg}	-65 to +150							$^\circ\text{C}$

Note: 1. Unit mounted on 9" x 3.5" x 4.6" thick (23 x 9 x 11.8mm) Al. finned plate.

2. Bolt down on heat-sink with silicone thermal compound between bridge and mounting surface for maximum heat transfer efficiency with #10 screw.

KBPC25005W THRU KBPC2510W

SINGLE-PHASE BRIDGE RECTIFIER

VOLTAGE RANGE 50 to 1000 Volts CURRENT 25.0 Ampere

RATING AND CHARACTERISTIC CURVES KBPC25005W THRU KBPC2510W

FIG.1-DERATING CURVE FOR OUTPUT RECTIFIED CURRENT

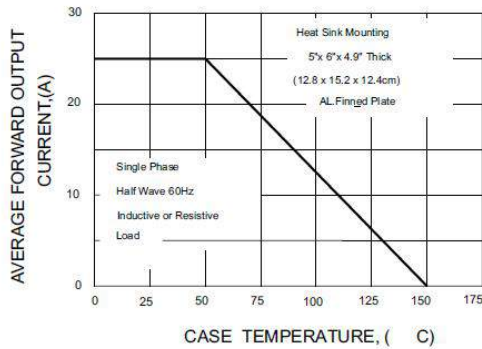

FIG.2-MAXIMUM NON-REPETITIVE PEAK FORWARD SURGE CURRENT PER ELEMENT

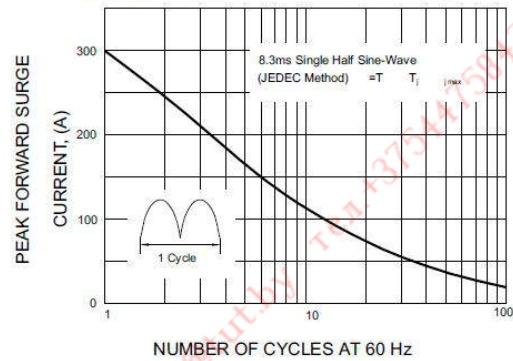

FIG.3-TYPICAL FORWARD CHARACTERISTICS PER BRIDGE ELEMENT

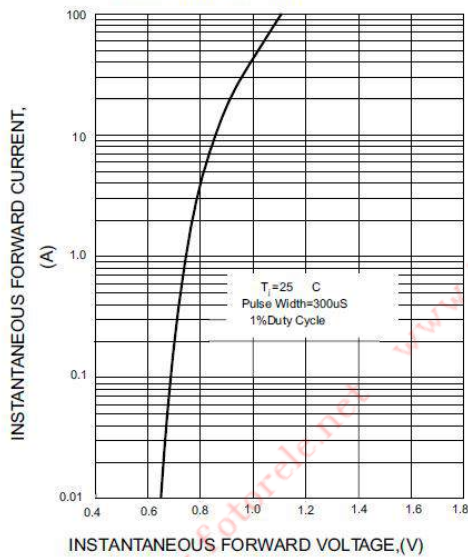

FIG.4-TYPICAL REVERSE CHARACTERISTICS PER BRIDGE ELEMENT

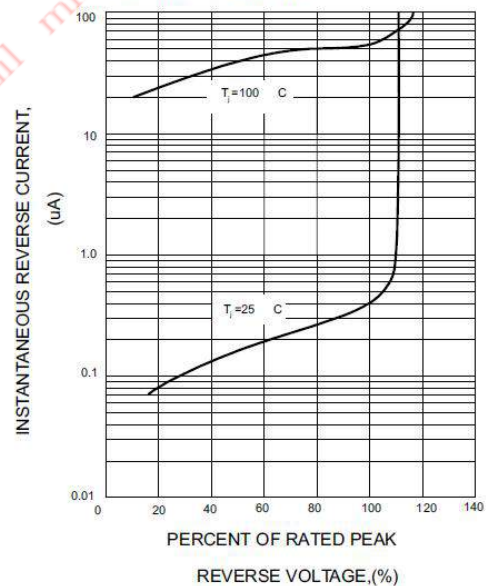

FIG.5-TYPICAL JUNCTION CAPACITANCE PER BRIDGE ELEMENT

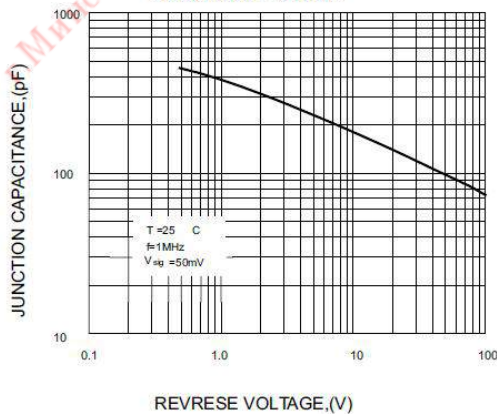
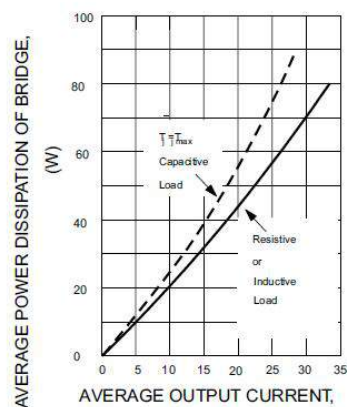

FIG.6-MAXIMUM POWER DISSIPATION



Note: Specifications are subject to change without notice. For more detail and update, please visit our website.

GBPC35005 THRU GBPC3510

SINGLE-PHASE BRIDGE RECTIFIER GLASS PASSIVATED BRIDGE RECTIFIERS
REVERSE VOLTAGE 50 to 1000 Volts FORWARD CURRENT 35 Ampere

FEATURES

- ◆ Rating to 1000V PRV.
- ◆ High efficiency.
- ◆ Glass passivated chip junction.
- ◆ Electrically isolated metal case for maximum heat dissipation.
- ◆ The plastic material has UL flammability classification 94V-0.
- ◆ Electrically isolated base-2500 Volts

Mechanical Data

- ◆ Case : Molded plastic with Heatsink internally mounted in the bridge encapsulation.
- ◆ Polarity: As marked on Body.
- ◆ Mounting : Hole for # 10 screw.
- ◆ Weight : 0.55 ounces , 15.6 grams (terminal) .

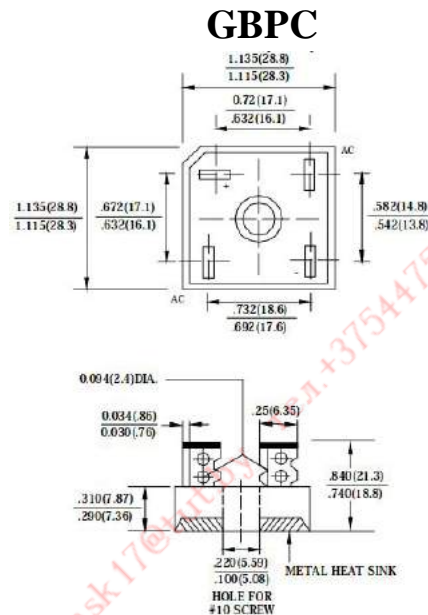

MAXIMUM RATINGS AND ELECTRICAL CHARACTERISTICS

Rating at 25°C ambient temperature unless otherwise specified.

Single phase, half wave, 60Hz, resistive or inductive load. For capacitive load, derate current by 20%

PARAMETER	SYMBOL	GBPC 35005	GBPC 3501	GBPC 3502	GBPC 3504	GBPC 3506	GBPC 3508	GBPC 3510	UNIT
Maximum Recurrent Peak Reverse Voltage	V_{RRM}	50	100	200	400	600	800	1000	V
Maximum RMS Voltage	V_{RMS}	35	70	140	280	420	560	700	V
Maximum DC Blocking Voltage	V_{DC}	50	100	200	400	600	800	1000	V
Maximum Average Forward(with heatsink Note 2) Rectified Current @ $T_C=110^\circ\text{C}$ (without heatsink)	$I_{(AV)}$	35.5							A
Peak Forward Surge Current 8.3ms single half sine-wave superimposed on rated load	I_{FSM}	400							A
Maximum forward Voltage at 17.5A DC	V_F	1.1							V
Maximum DC Reverse Current @ $T_J=25^\circ\text{C}$ at Rated DC Blocking voltage @ $T_J=125^\circ\text{C}$	I_R	500							μA
I^2t Rating for fusing($t<8.3\text{ms}$)	I^2t	660							A^2S
Typical Junction Capacitance per element(Note 1)	C_J	300							pF
Typical Thermal Resistance (Note 2)	$R_{\theta JC}$	1.4							$^\circ\text{C}/\text{W}$
Operating Temperature Range	T_J	-55 to +150							$^\circ\text{C}$
Storage Temperature Range	T_{STG}	-55 to +150							$^\circ\text{C}$

- Note : 1. Measured at non-repetitive, for greater than 1ms and less than 8.3ms.
2. Measured at 1.0M Hz and applied reversed voltage of 4.0 VDC.
3. Device mounted on 300mm x 300mm x 1.6mm Cu Plate Heatsink.

GBPC35005 THRU GBPC3510

SINGLE-PHASE BRIDGE RECTIFIER GLASS PASSIVATED BRIDGE RECTIFIER
 REVERSE VOLTAGE 50 to 1000 Volts FORWARD CURRENT 35 Ampere

RATING AND CHARACTERISTIC CURVES GBPC35005 THRU GBPC3510

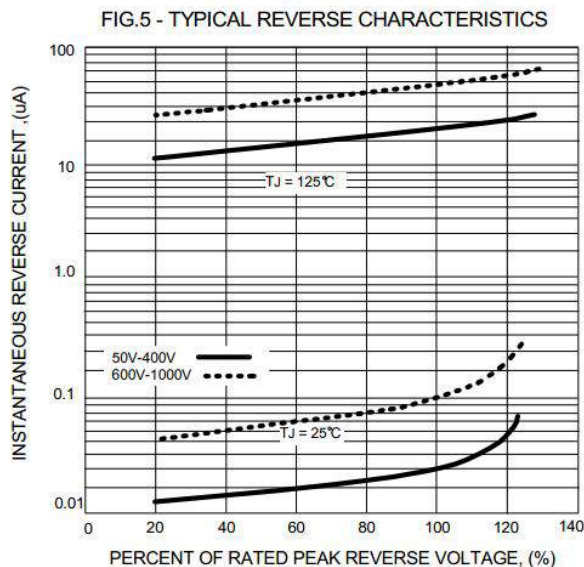
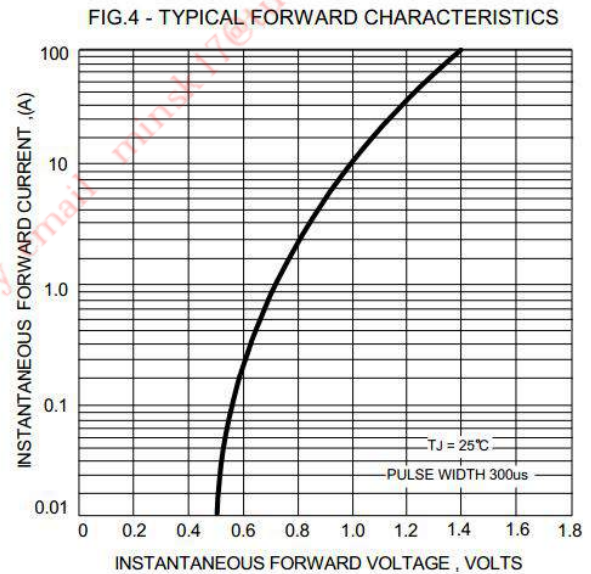
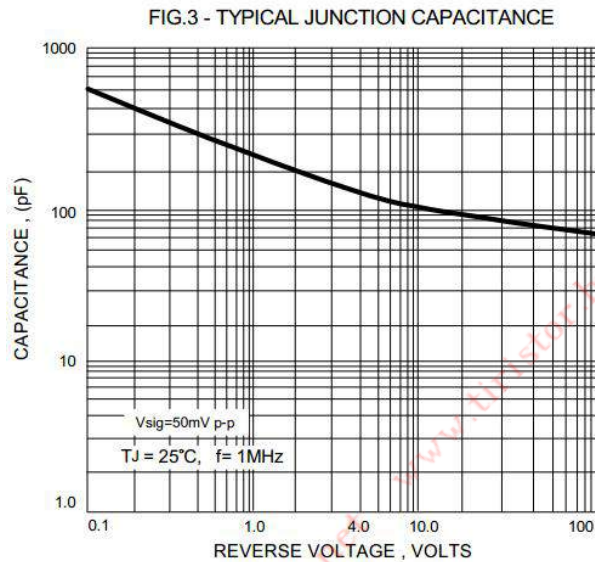
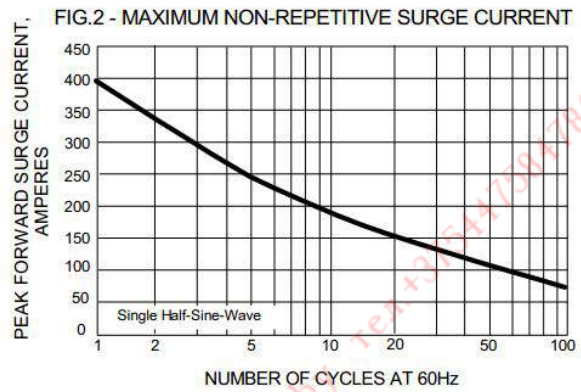
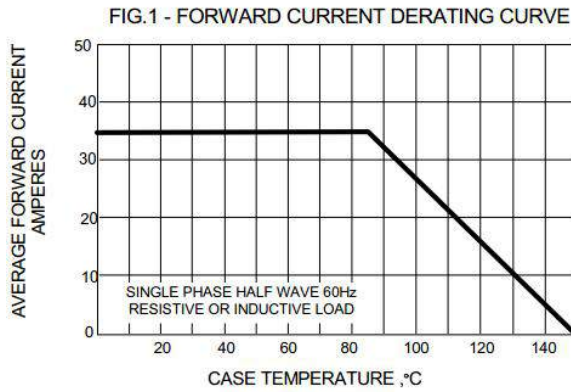

Note: Specifications are subject to change without notice. For more detail and update, please visit our website.

GBPC50005 THRU GBPC5010

SINGLE-PHASE BRIDGE RECTIFIER GLASS PASSIVATED BRIDGE RECTIFIERS
 REVERSE VOLTAGE 50 to 1000 Volts FORWARD CURRENT 50 Ampere

FEATURES

- ◆ Rating to 1000V PRV.
- ◆ High efficiency.
- ◆ Glass passivated chip junction.
- ◆ Electrically isolated metal case for maximum heat dissipation.
- ◆ The plastic material has UL flammability classification 94V-0.
- ◆ Electrically isolated base-2500 Volts

Mechanical Data

- ◆ Case : Molded plastic with Heatsink internally mounted in the bridge encapsulation.
- ◆ Polarity: As marked on Body.
- ◆ Mounting : Hole for # 10 screw.
- ◆ Weight : 0.63 ounces , 18.0 grams (terminal)
0.51 ounces , 14.5 grams (wire).

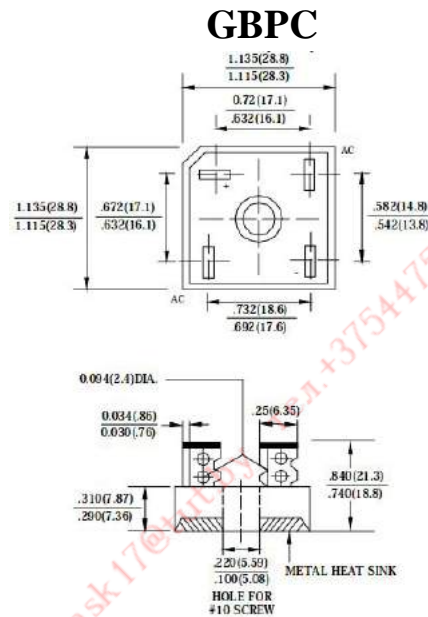

Dimensions in inches and (millimeters)

MAXIMUM RATINGS AND ELECTRICAL CHARACTERISTICS

Rating at 25°C ambient temperature unless otherwise specified.

Single phase, half wave, 60Hz, resistive or inductive load. For capacitive load, derate current by 20%

PARAMETER	SYMBOL	GBPC 50005	GBPC 5001	GBPC 5002	GBPC 5004	GBPC 5006	GBPC 5008	GBPC 5010	UNIT
Maximum Recurrent Peak Reverse Voltage	V_{RRM}	50	100	200	400	600	800	1000	V
Maximum RMS Voltage	V_{RMS}	35	70	140	280	420	560	700	V
Maximum DC Blocking Voltage	V_{DC}	50	100	200	400	600	800	1000	V
Maximum Average Forward(with heatsink Note 2) Rectified Current @ $T_C=110^\circ\text{C}$ (without heatsink)	$I_{(AV)}$	50.5							A
Peak Forward Surge Current 8.3ms single half sine-wave superimposed on rated load	I_{FSM}	450							A
Maximum forward Voltage at 25A DC	V_F	1.1							V
Maximum DC Reverse Current @ $T_J=25^\circ\text{C}$ at Rated DC Blocking voltage @ $T_J=125^\circ\text{C}$	I_R	5.0 500							μA
I^2t Rating for fusing($t<8.3\text{ms}$)	I^2t	800							A^2S
Typical Junction Capacitance per element(Note 1)	C_J	150							pF
Typical Thermal Resistance (Note 2)	$R_{\theta JC}$	1.4							$^\circ\text{C}/\text{W}$
Operating Temperature Range	T_J	-55 to +150							$^\circ\text{C}$
Storage Temperature Range	T_{STG}	-55 to +150							$^\circ\text{C}$

- Note : 1. Measured at non-repetitive, for greater than 1ms and less than 8.3ms.
 2. Measured at 1.0M Hz and applied reversed voltage of 4.0 VDC.
 3. Device mounted on 300mm x 300mm x 1.6mm Cu Plate Heatsink.

GBPC50005 THRU GBPC5010

SINGLE-PHASE BRIDGE RECTIFIER GLASS PASSIVATED BRIDGE RECTIFIER
 REVERSE VOLTAGE 50 to 1000 Volts FORWARD CURRENT 50 Ampere

RATING AND CHARACTERISTIC CURVES GBPC50005 THRU GBPC5010

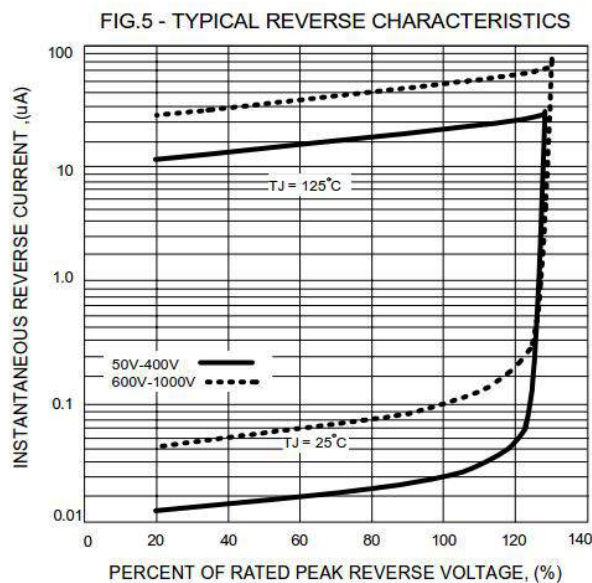
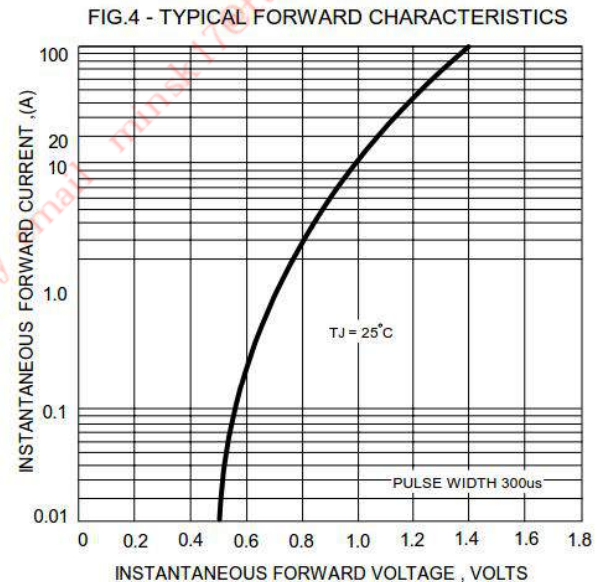
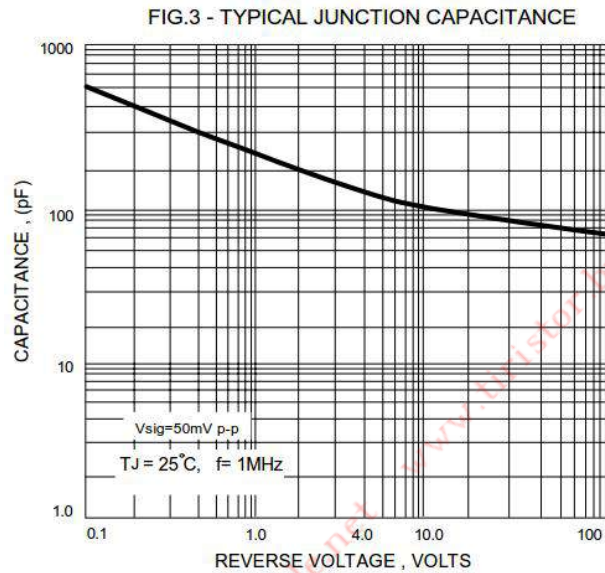
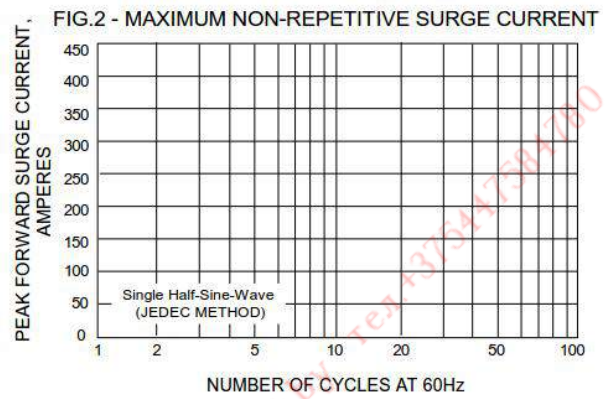
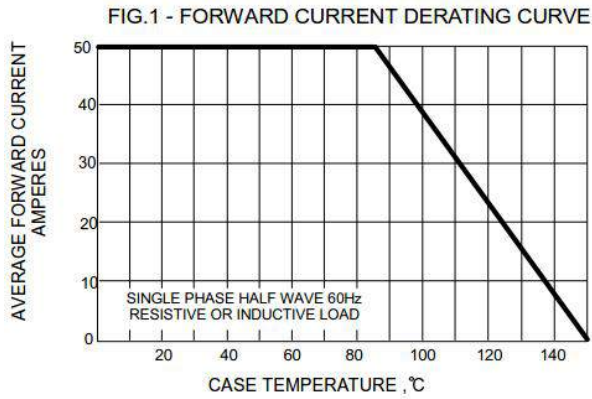

Note: Specifications are subject to change without notice. For more detail and update, please visit our website.

GBPC15005W THRU GBPC1510W

SINGLE-PHASE BRIDGE RECTIFIER GLASS PASSIVATED BRIDGE RECTIFIERS
REVERSE VOLTAGE 50 to 1000 Volts FORWARD CURRENT 15 Ampere

FEATURES

- ◆ Rating to 1000V PRV.
- ◆ High efficiency.
- ◆ Glass passivated chip junction.
- ◆ Electrically isolated metal case for maximum heat dissipation.
- ◆ The plastic material has UL flammability classification 94V-0.
- ◆ Electrically isolated base-2500 Volts

Mechanical Data

- ◆ Case : Molded plastic with Heatsink internally mounted in the bridge encapsulation.
- ◆ Polarity: As marked on Body.
- ◆ Mounting : Hole for # 10 screw.
- ◆ Weight : 0.47 ounces , 13.4 grams (wire).

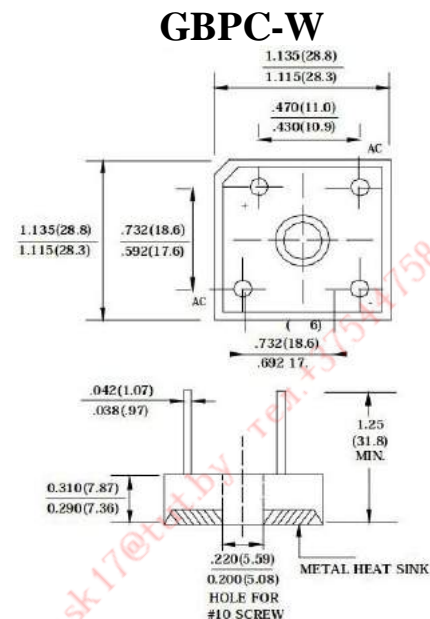

Dimensions in inches and (millimeters)

MAXIMUM RATINGS AND ELECTRICAL CHARACTERISTICS

Rating at 25°C ambient temperature unless otherwise specified.

Single phase, half wave, 60Hz, resistive or inductive load. For capacitive load, derate current by 20%

PARAMETER	SYMBOL	GBPC 15005W	GBPC 1501W	GBPC 1502W	GBPC 1504W	GBPC 1506W	GBPC 1508W	GBPC 1510W	UNIT
Maximum Recurrent Peak Reverse Voltage	V_{RRM}	50	100	200	400	600	800	1000	V
Maximum RMS Voltage	V_{RMS}	35	70	140	280	420	560	700	V
Maximum DC Blocking Voltage	V_{DC}	50	100	200	400	600	800	1000	V
Maximum Average Forward(with heatsink Note 2) Rectified Current @ $T_C=110^\circ\text{C}$ (without heatsink)	$I_{(AV)}$	15.0							A
Peak Forward Surge Current 8.3ms single half sine-wave superimposed on rated load	I_{FSM}	300							A
Maximum forward Voltage at 7.5A DC	V_F	1.1							V
Maximum DC Reverse Current @ $T_J=25^\circ\text{C}$ at Rated DC Blocking voltage @ $T_J=125^\circ\text{C}$	I_R	5.0 500							μA
I^2t Rating for fusing($t<8.3\text{ms}$)	I^2t	374							A^2S
Typical Junction Capacitance per element(Note 1)	C_J	110							pF
Typical Thermal Resistance (Note 2)	$R_{\theta JC}$	1.9							$^\circ\text{C}/\text{W}$
Operating Temperature Range	T_J	-55 to +150							$^\circ\text{C}$
Storage Temperature Range	T_{STG}	-55 to +150							$^\circ\text{C}$

Note: 1. Measured at 1.0M Hz and applied reversed voltage of 4.0 VDC.

2. Measured at non-repetitive, for greater than 1ms and less than 8.3ms.

3. Device mounted on 300mm x 300mm x 1.6mm Cu Plate Heatsink.

GBPC15005W THRU GBPC1510W

SINGLE-PHASE BRIDGE RECTIFIER GLASS PASSIVATED BRIDGE RECTIFIER
 REVERSE VOLTAGE 50 to 1000 Volts FORWARD CURRENT 15 Ampere

RATING AND CHARACTERISTIC CURVES GBPC15005W THRU GBPC1510W

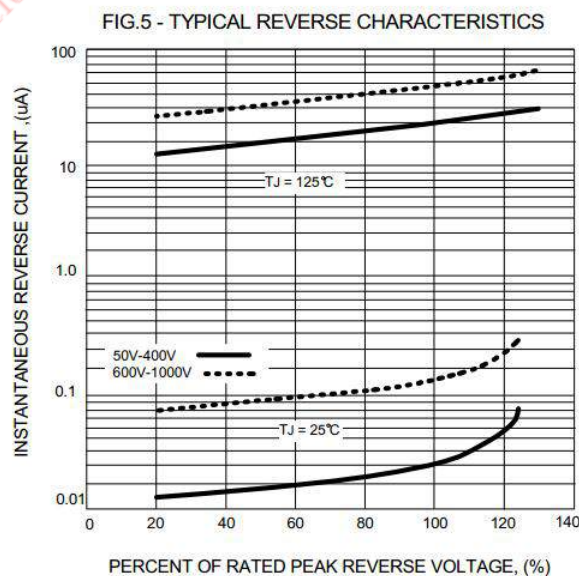
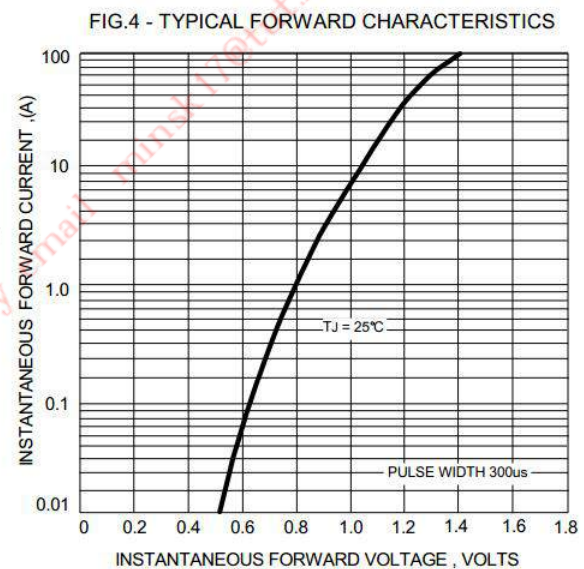
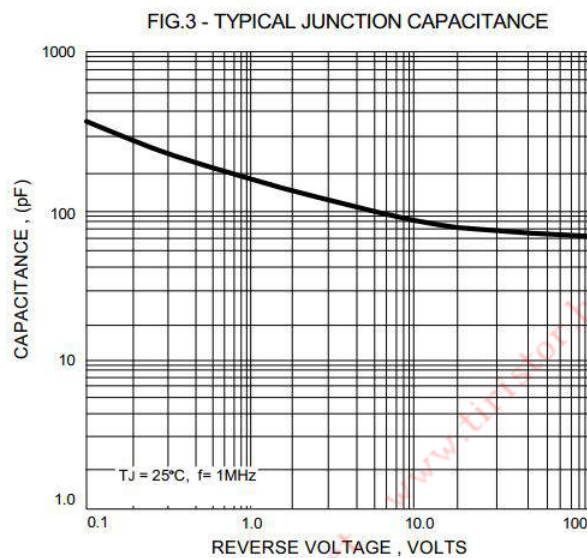
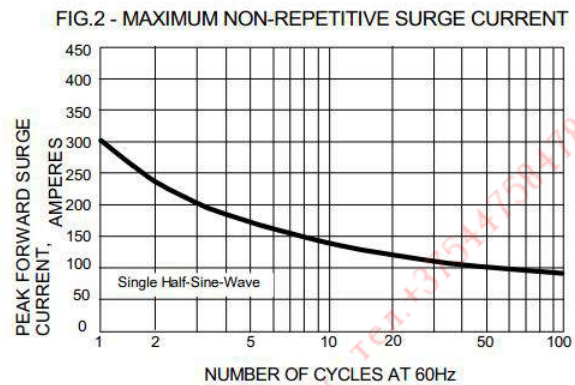
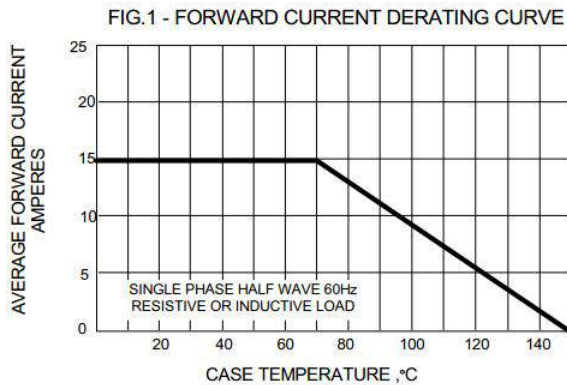

Note: Specifications are subject to change without notice. For more detail and update, please visit our website.

GBPC25005W THRU GBPC2510W

SINGLE-PHASE BRIDGE RECTIFIER GLASS PASSIVATED BRIDGE RECTIFIERS
REVERSE VOLTAGE 50 to 1000 Volts FORWARD CURRENT 25 Ampere

FEATURES

- ◆ Rating to 1000V PRV.
- ◆ High efficiency.
- ◆ Glass passivated chip junction.
- ◆ Electrically isolated metal case for maximum heat dissipation.
- ◆ The plastic material has UL flammability classification 94V-0.
- ◆ Electrically isolated base-2500 Volts

Mechanical Data

- ◆ Case : Molded plastic with Heatsink internally mounted in the bridge encapsulation.
- ◆ Polarity: As marked on Body.
- ◆ Mounting : Hole for # 10 screw.
- ◆ Weight :0.47 ounces , 13.4 grams (wire).

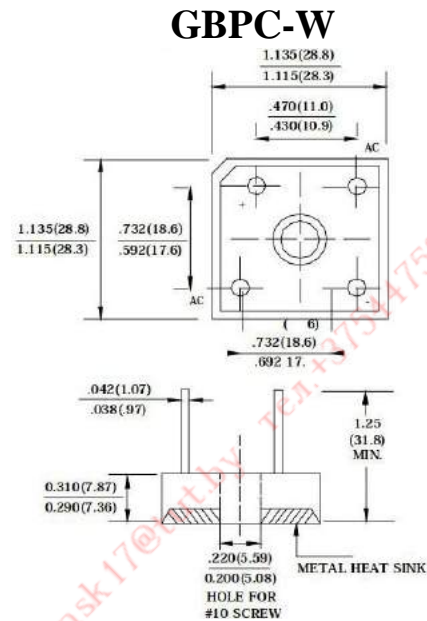

MAXIMUM RATINGS AND ELECTRICAL CHARACTERISTICS

Rating at 25°C ambient temperature unless otherwise specified.

Single phase, half wave, 60Hz, resistive or inductive load. For capacitive load, derate current by 20%

PARAMETER	SYMBOL	GBPC 25005W	GBPC 2501W	GBPC 2502W	GBPC 2504W	GBPC 2506W	GBPC 2508W	GBPC 2510W	UNIT
Maximum Recurrent Peak Reverse Voltage	V_{RRM}	50	100	200	400	600	800	1000	V
Maximum RMS Voltage	V_{RMS}	35	70	140	280	420	560	700	V
Maximum DC Blocking Voltage	V_{DC}	50	100	200	400	600	800	1000	V
Maximum Average Forward(with heatsink Note 2) Rectified Current @ $T_C=110^{\circ}C$ (without heatsink)	$I_{(AV)}$	25.0							A
Peak Forward Surge Current 8.3ms single half sine-wave superimposed on rated load	I_{FSM}	300							A
Maximum forward Voltage at 12.5A DC	V_F	1.1							V
Maximum DC Reverse Current @ $T_J=25^{\circ}C$ at Rated DC Blocking voltage @ $T_J=125^{\circ}C$	I_R	500							μA
I^2t Rating for fusing($t<8.3ms$)	I^2t	508							A^2S
Typical Junction Capacitance per element(Note 1)	C_J	130							pF
Typical Thermal Resistance (Note 2)	$R_{\theta JC}$	1.9							$^{\circ}C/W$
Operating Temperature Range	T_J	-55 to +150							$^{\circ}C$
Storage Temperature Range	T_{STG}	-55 to +150							$^{\circ}C$

- Note: 1. Measured at non-repetitive, for greater than 1ms and less than 8.3ms.
2. Measured at 1.0M Hz and applied reversed voltage of 4.0 VDC.
3. Device mounted on 300mm x 300mm x 1.6mm Cu Plate Heatsink.

GBPC25005W THRU GBPC2510W

SINGLE-PHASE BRIDGE RECTIFIER GLASS PASSIVATED BRIDGE RECTIFIER
 REVERSE VOLTAGE 50 to 1000 Volts FORWARD CURRENT 25 Ampere

RATING AND CHARACTERISTIC CURVES GBPC25005W THRU GBPC2510W

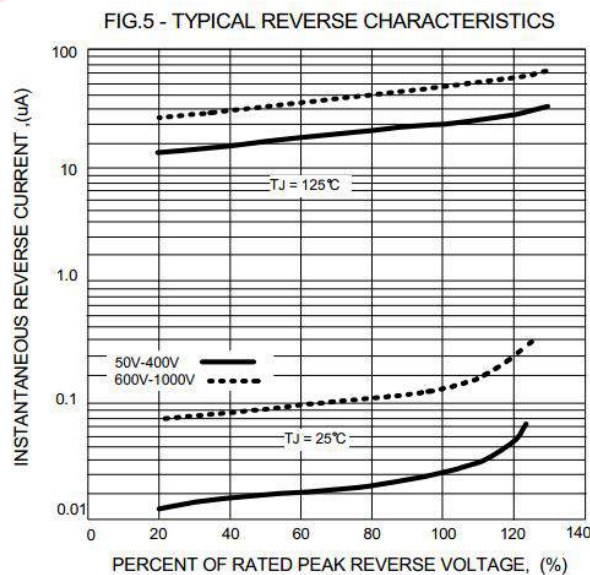
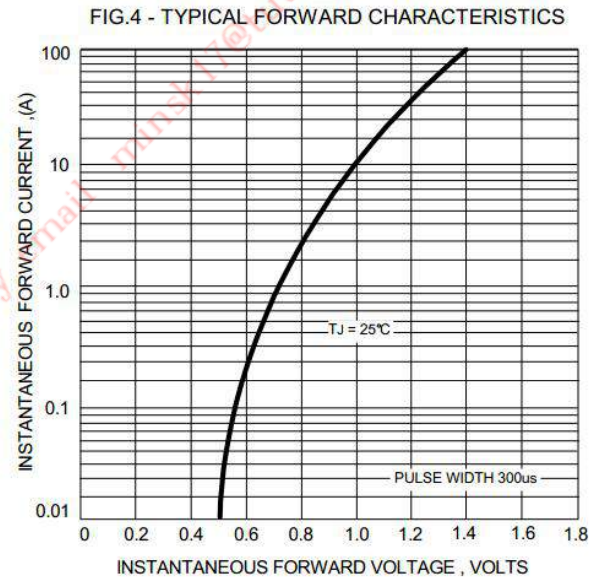
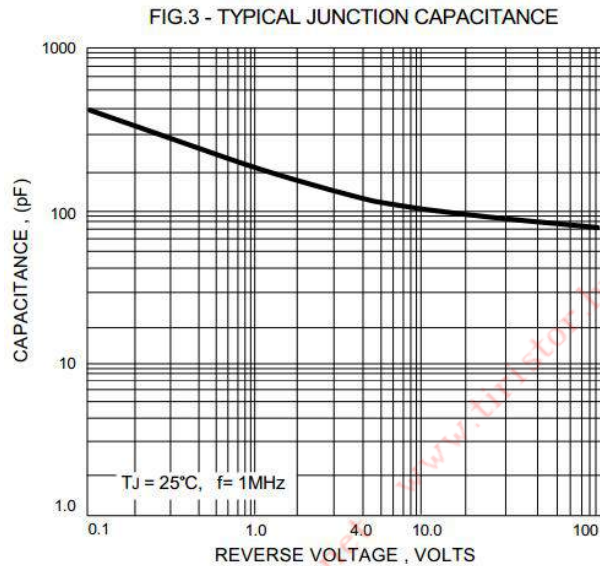
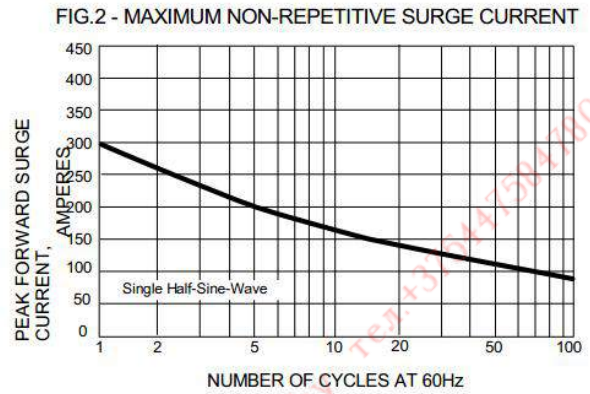
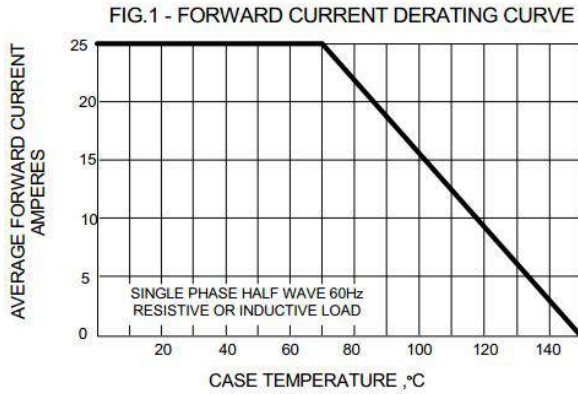

Note: Specifications are subject to change without notice. For more detail and update, please visit our website.

GBPC35005W THRU GBPC3510W

SINGLE-PHASE BRIDGE RECTIFIER GLASS PASSIVATED BRIDGE RECTIFIERS
REVERSE VOLTAGE 50 to 1000 Volts FORWARD CURRENT 35 Ampere

FEATURES

- ◆ Rating to 1000V PRV.
- ◆ High efficiency.
- ◆ Glass passivated chip junction.
- ◆ Electrically isolated metal case for maximum heat dissipation.
- ◆ The plastic material has UL flammability classification 94V-0.
- ◆ Electrically isolated base-2500 Volts

Mechanical Data

- ◆ Case : Molded plastic with Heatsink internally mounted in the bridge encapsulation.
- ◆ Polarity: As marked on Body.
- ◆ Mounting : Hole for # 10 screw.
- ◆ Weight : 0.47 ounces , 13.4 grams (wire) .

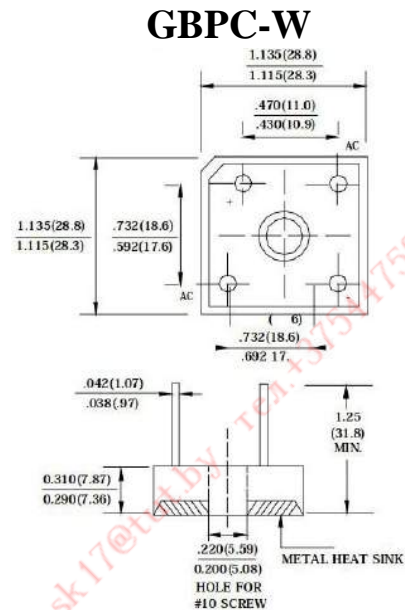

MAXIMUM RATINGS AND ELECTRICAL CHARACTERISTICS

Rating at 25°C ambient temperature unless otherwise specified.

Single phase, half wave, 60Hz, resistive or inductive load. For capacitive load, derate current by 20%

PARAMETER	SYMBOL	GBPC 35005W	GBPC 3501W	GBPC 3502W	GBPC 3504W	GBPC 3506W	GBPC 3508W	GBPC 3510W	UNIT
Maximum Recurrent Peak Reverse Voltage	V_{RRM}	50	100	200	400	600	800	1000	V
Maximum RMS Voltage	V_{RMS}	35	70	140	280	420	560	700	V
Maximum DC Blocking Voltage	V_{DC}	50	100	200	400	600	800	1000	V
Maximum Average Forward(with heatsink Note 2) Rectified Current @ $T_C=110^\circ\text{C}$ (without heatsink)	$I_{(AV)}$	35.0							A
Peak Forward Surge Current 8.3ms single half sine-wave superimposed on rated load	I_{FSM}	400							A
Maximum forward Voltage at 17.5A DC	V_F	1.1							V
Maximum DC Reverse Current @ $T_J=25^\circ\text{C}$ at Rated DC Blocking voltage @ $T_J=125^\circ\text{C}$	I_R	500							μA
I^2t Rating for fusing($t<8.3\text{ms}$)	I^2t	660							A^2S
Typical Junction Capacitance per element(Note 1)	C_J	150							pF
Typical Thermal Resistance (Note 2)	$R_{\theta JC}$	1.4							$^\circ\text{C}/\text{W}$
Operating Temperature Range	T_J	-55 to +150							$^\circ\text{C}$
Storage Temperature Range	T_{STG}	-55 to +150							$^\circ\text{C}$

Note : 1. Measured at non-repetitive, for greater than 1ms and less than 8.3ms.

2.Measured at 1.0M Hz and applied reversed voltage of 4.0 VDC.

3. Device mounted on 300mm x 300mm x 1.6mm Cu Plate Heatsink.

GBPC35005W THRU GBPC3510W

SINGLE-PHASE BRIDGE RECTIFIER GLASS PASSIVATED BRIDGE RECTIFIER
 REVERSE VOLTAGE 50 to 1000 Volts FORWARD CURRENT 35 Ampere

RATING AND CHARACTERISTIC CURVES GBPC35005W THRU GBPC3510W

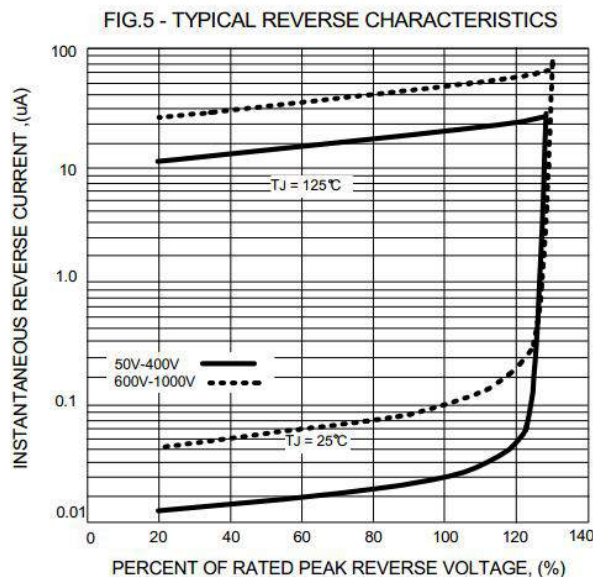
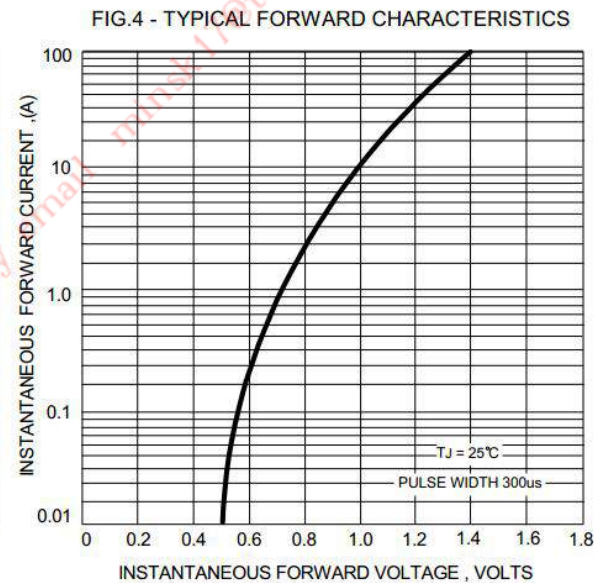
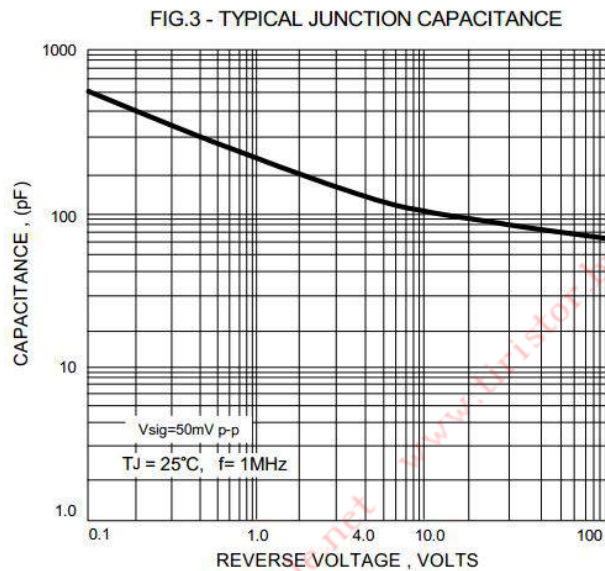
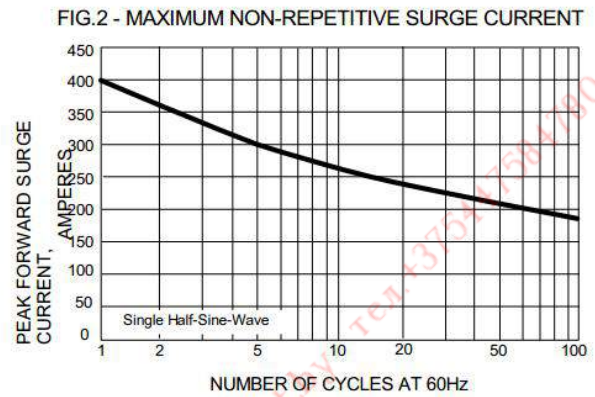
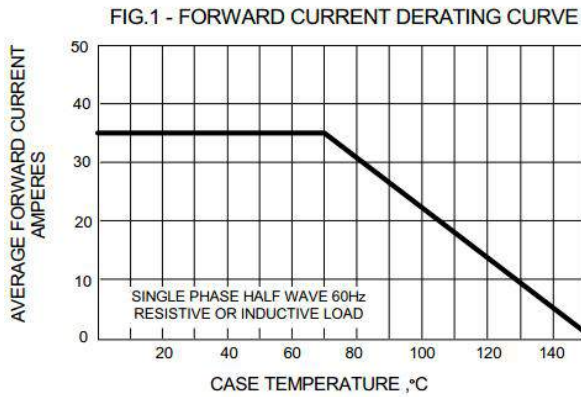

Note: Specifications are subject to change without notice. For more detail and update, please visit our website.

GBPC50005W THRU GBPC5010W

SINGLE-PHASE BRIDGE RECTIFIER GLASS PASSIVATED BRIDGE RECTIFIERS
REVERSE VOLTAGE 50 to 1000 Volts FORWARD CURRENT 50 Ampere

FEATURES

- ◆ Rating to 1000V PRV.
- ◆ High efficiency.
- ◆ Glass passivated chip junction.
- ◆ Electrically isolated metal case for maximum heat dissipation.
- ◆ The plastic material has UL flammability classification 94V-0.
- ◆ Electrically isolated base-2500 Volts

Mechanical Data

- ◆ Case : Molded plastic with Heatsink internally mounted in the bridge encapsulation.
- ◆ Polarity: As marked on Body.
- ◆ Mounting : Hole for # 10 screw.
- ◆ Weight : 0.63 ounces , 18.0 grams (terminal)
0.51 ounces , 14.5 grams (wire).

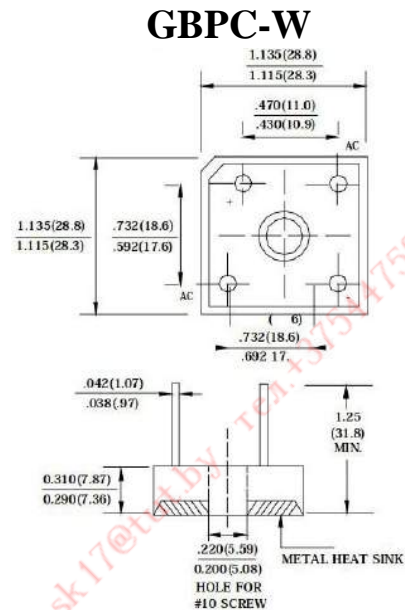

MAXIMUM RATINGS AND ELECTRICAL CHARACTERISTICS

Rating at 25°C ambient temperature unless otherwise specified.

Single phase, half wave, 60Hz, resistive or inductive load. For capacitive load, derate current by 20%

PARAMETER	SYMBOL	GBPC 50005W	GBPC 5001W	GBPC 5002W	GBPC 5004W	GBPC 5006W	GBPC 5008W	GBPC 5010W	UNIT
Maximum Recurrent Peak Reverse Voltage	V_{RRM}	50	100	200	400	600	800	1000	V
Maximum RMS Voltage	V_{RMS}	35	70	140	280	420	560	700	V
Maximum DC Blocking Voltage	V_{DC}	50	100	200	400	600	800	1000	V
Maximum Average Forward(with heatsink Note 2) Rectified Current @ $T_C=110^\circ\text{C}$ (without heatsink)	$I_{(AV)}$	50.0							A
Peak Forward Surge Current 8.3ms single half sine-wave superimposed on rated load	I_{FSM}	400							A
Maximum forward Voltage at 25A DC	V_F	1.1							V
Maximum DC Reverse Current @ $T_J=25^\circ\text{C}$ at Rated DC Blocking voltage @ $T_J=125^\circ\text{C}$	I_R	5.0 500							μA
I^2t Rating for fusing($t<8.3\text{ms}$)	I^2t	800							A^2S
Typical Junction Capacitance per element(Note 1)	C_J	150							pF
Typical Thermal Resistance (Note 2)	$R_{\theta JC}$	1.4							$^\circ\text{C}/\text{W}$
Operating Temperature Range	T_J	-55 to +150							$^\circ\text{C}$
Storage Temperature Range	T_{STG}	-55 to +150							$^\circ\text{C}$

- Note : 1. Measured at non-repetitive, for greater than 1ms and less than 8.3ms.
2. Measured at 1.0M Hz and applied reversed voltage of 4.0 VDC.
3. Device mounted on 300mm x 300mm x 1.6mm Cu Plate Heatsink.

GBPC50005W THRU GBPC5010W

SINGLE-PHASE BRIDGE RECTIFIER GLASS PASSIVATED BRIDGE RECTIFIER
 REVERSE VOLTAGE 50 to 1000 Volts FORWARD CURRENT 50 Ampere

RATING AND CHARACTERISTIC CURVES GBPC50005W THRU GBPC5010W

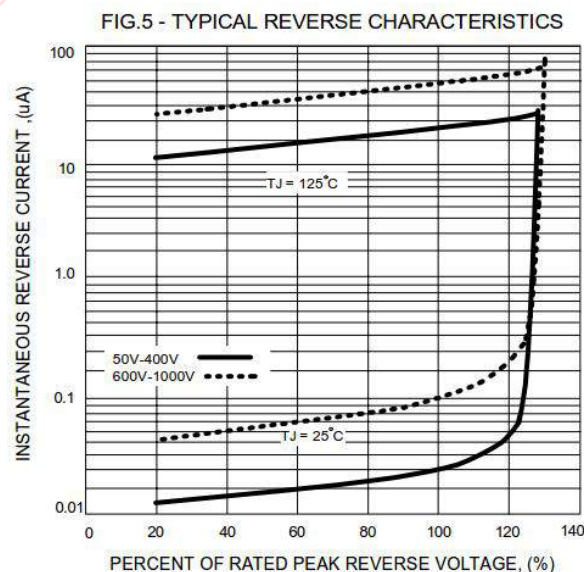
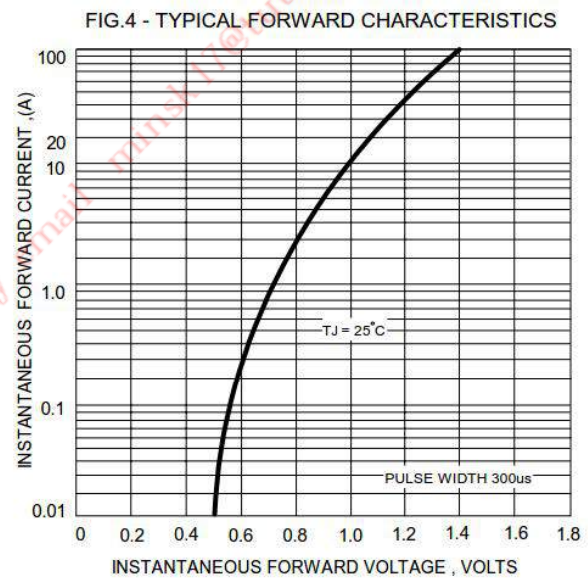
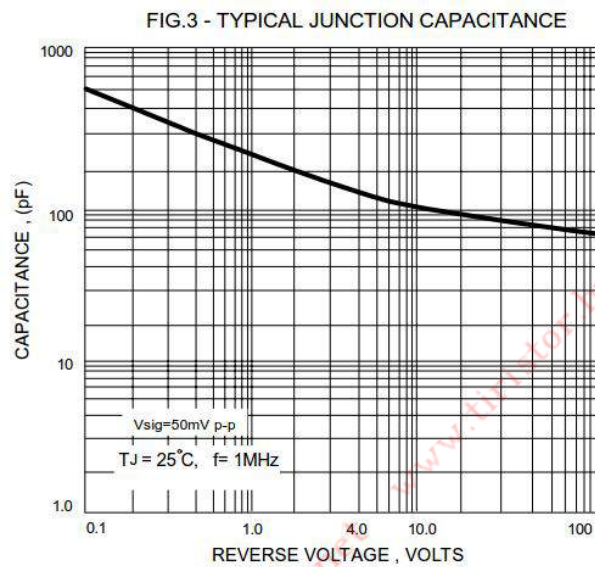
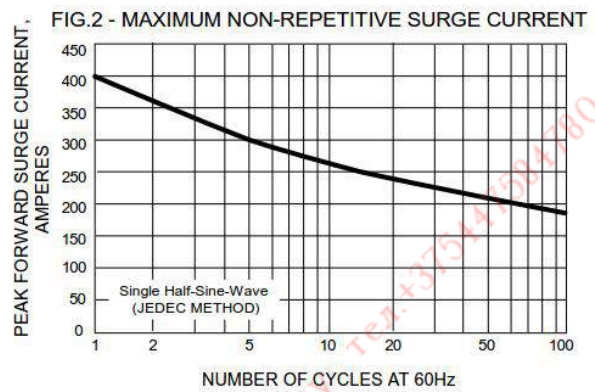
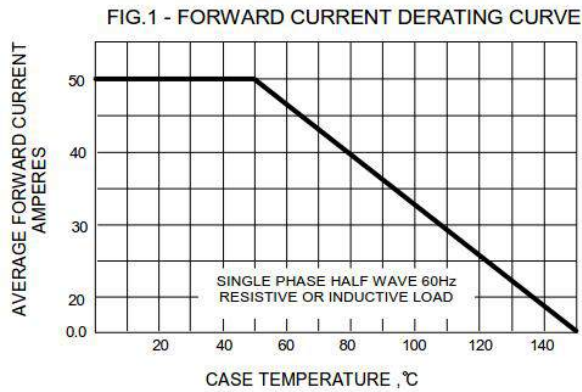

Note: Specifications are subject to change without notice. For more detail and update, please visit our website.

SKBPC1504 THRU SKBPC1516

THREE PHASE GLASS PASSIVATED BRIDGE RECTIFIER
REVERSE VOLTAGE 400 to 1600 Volts FORWARD CURRENT 15 Ampere

FEATURES

- ◆ I_o 15A
- ◆ V_{RRM} 400V~1600V
- ◆ Glass passivated chip
- ◆ High surge forward current capability

SKBPC

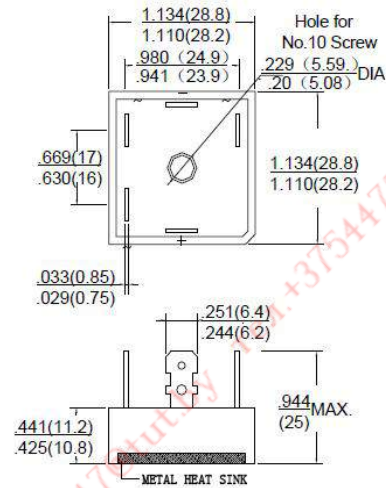

Dimensions in inches and (millimeters)

MAXIMUM RATINGS AND ELECTRICAL CHARACTERISTICS

Rating at 25°C ambient temperature unless otherwise specified.

Single phase, half wave, 60Hz, resistive or inductive load. For capacitive load, derate current by 20%

PARAMETER	SYMBOL	Conditions	SKBC 1504	SKBPC 1506	SKBPC 1508	SKBPC 1510	SKBPC 1512	SKBPC 1514	SKBPC 1516	UNIT
Repetitive Peak Reverse Voltage	V _{RRM}		400	600	800	1000	1200	1400	1600	V
Average Rectified Output Current	I _o	60Hz sine wave, R-load With heatsink T _c =55°C	15							A
Surge(Nonrepetitive) Forward Current	I _{FSM}	60Hz sine wave, 1 cycle, T _a =25°C	300							A
Current Squared Time	I ² t	1ms ≤ t < 8.3ms T _j =25°C Rating of per diode	375							A ² S
Storage Temperature	T _{STG}		-40~+150							°C
Junction Temperature	T _j		-55~+150							°C
Dielectric Strength	V _{dis}	Terminals to case, AC 1 minute	2.5							KV
Item	SYMBOL	UNIT	Test Condition							Max
Peak Forward Voltage	V _{FM}	V	I _{FM} =7.5A, Pulse measurement, Rating of per							1.2
Peak Reverse Current	I _{RRM}	μA	V _{RM} =V _{RRM} , Pulse measurement, Rating of per diode							10
Thermal Resistance	R _{θj-c}	°C/W	Between junction and case, With heatsink							3.0

SKBPC1504 THRU SKBPC1516

General purpose 3 phase Bridge Rectifier

REVERSE VOLTAGE 400 to 1600 Volts FORWARD CURRENT 15 Ampere

RATING AND CHARACTERISTIC CURVES SKBPC1504 THRU SKBPC1516

图1: I_o - T_c 曲线
FIG1: I_o - T_c Curve



图2: 耐正向浪涌电流曲线
FIG2: Surge Forward Current Capability



图3: 正向电压曲线
FIG3: Instantaneous Forward Voltage

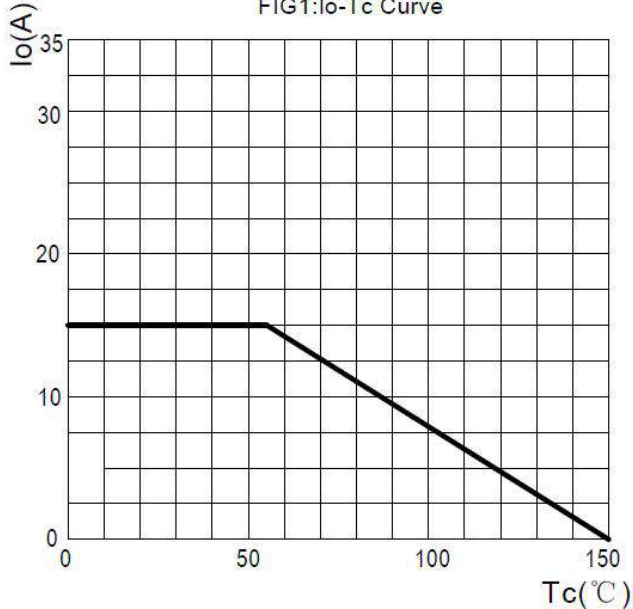

图4: 反向电流曲线
FIG4: Typical Reverse Characteristics

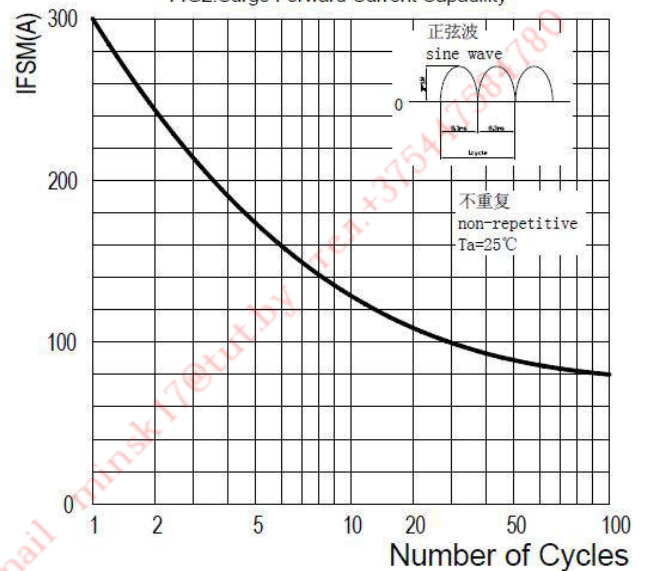

Note: Specifications are subject to change without notice. For more detail and update, please visit our website.

SKBPC2504 THRU SKBPC2516

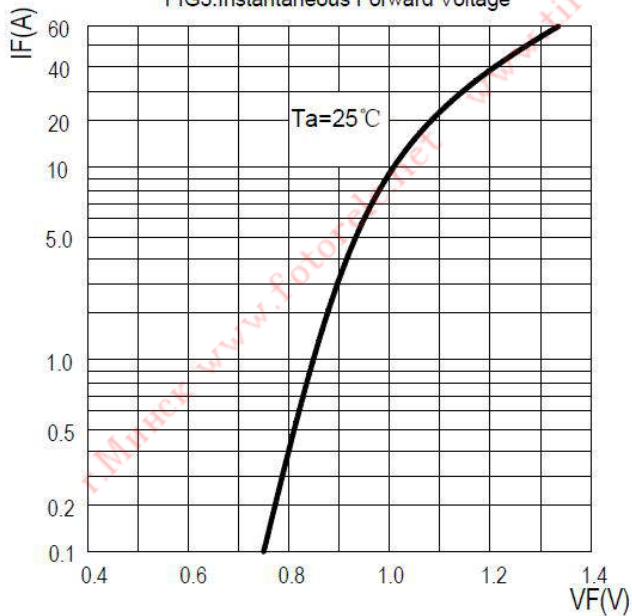
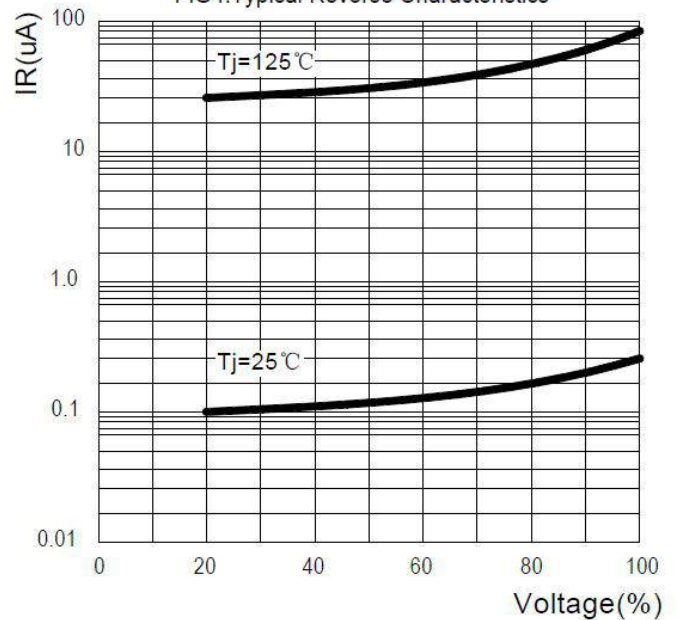
THREE PHASE GLASS PASSIVATED BRIDGE RECTIFIER
 REVERSE VOLTAGE 400 to 1600 Volts FORWARD CURRENT 25 Ampere

FEATURES

- ◆ I_o 25A
- ◆ V_{RRM} 400V~1600V
- ◆ Glass passivated chip
- ◆ High surge forward current capability

SKBPC

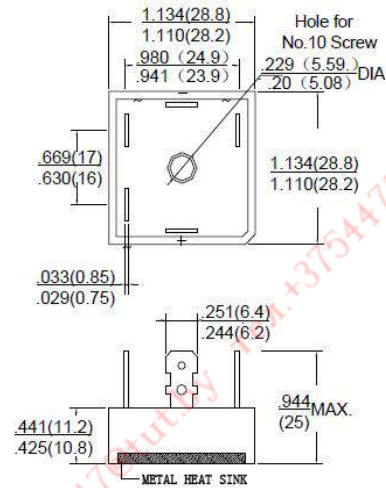

Dimensions in inches and (millimeters)

MAXIMUM RATINGS AND ELECTRICAL CHARACTERISTICS

Rating at 25°C ambient temperature unless otherwise specified.

Single phase, half wave, 60Hz, resistive or inductive load. For capacitive load, derate current by 20%

PARAMETER	SYMBOL	Conditions	SKBC 2504	SKBPC 2506	SKBPC 2508	SKBPC 2510	SKBPC 2512	SKBPC 2514	SKBPC 2516	UNIT
Repetitive Peak Reverse Voltage	V _{RRM}		400	600	800	1000	1200	1400	1600	V
Average Rectified Output Current	I _O	60Hz sine wave, R-load With heatsink T _c =55°C	25							A
Surge(Nonrepetitive) Forward Current	I _{FSM}	60Hz sine wave, 1 cycle, T _a =25°C	360							A
Current Squared Time	I ² t	1ms≤t<8.3ms T _j =25°C Rating of per diode	540							A ² S
Storage Temperature	T _{STG}		-40~+150							°C
Junction Temperature	T _J		-55~+150							°C
Dielectric Strength	V _{dis}	Terminals to case, AC 1 minute	2.5							KV
Item	SYMBOL	UNIT	Test Condition							Max
Peak Forward Voltage	V _{FM}	V	I _{FM} =8.5A, Pulse measurement, Rating of per							1.2
Peak Reverse Current	I _{RRM}	μA	V _{RM} =V _{RRM} , Pulse measurement, Rating of per diode							10
Thermal Resistance	R _{θJ-C}	°C/W	Between junction and case, With heatsink							1.9

SKBPC2504 THRU SKBPC2516

General purpose 3 phase Bridge Rectifier

REVERSE VOLTAGE 400 to 1600 Volts FORWARD CURRENT 25 Ampere

RATING AND CHARACTERISTIC CURVES SKBPC2504 THRU SKBPC2516

图1: I_o - T_c 曲线
FIG1: I_o - T_c Curve



图2: 耐正向浪涌电流曲线
FIG2: Surge Forward Current Capacity



图3: 正向电压曲线
FIG3: Instantaneous Forward Voltage

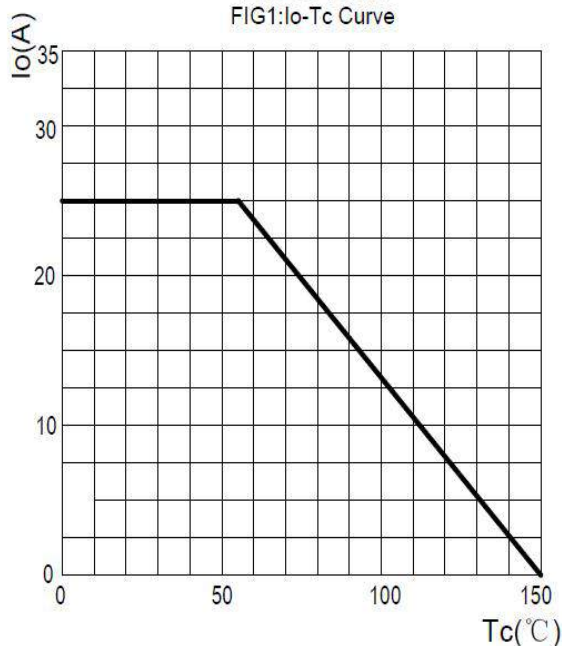

图4: 反向电流曲线
FIG4: Typical Reverse Characteristics

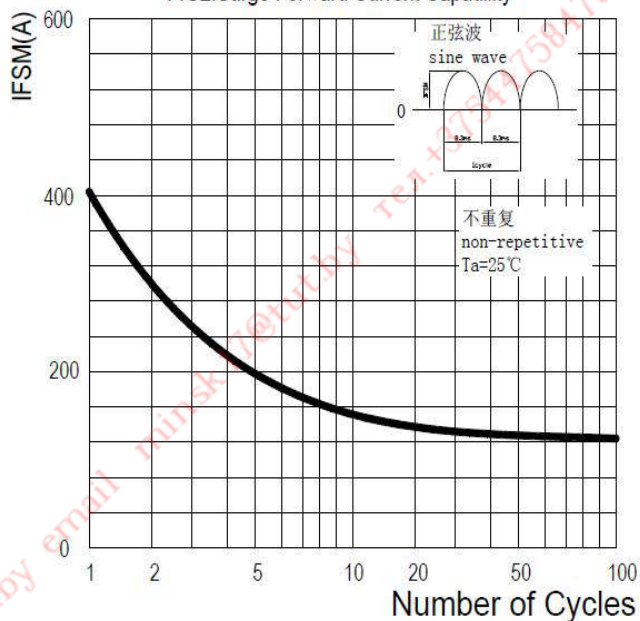

Note: Specifications are subject to change without notice. For more detail and update, please visit our website.

SKBPC3504 THRU SKBPC3516

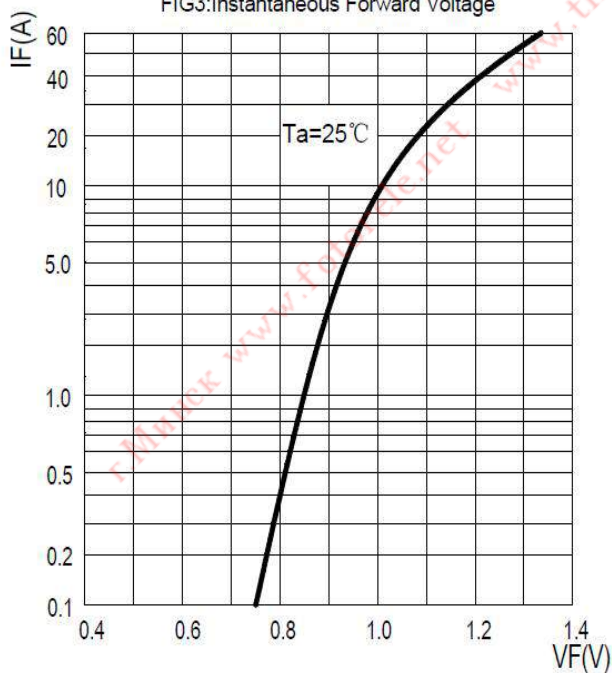
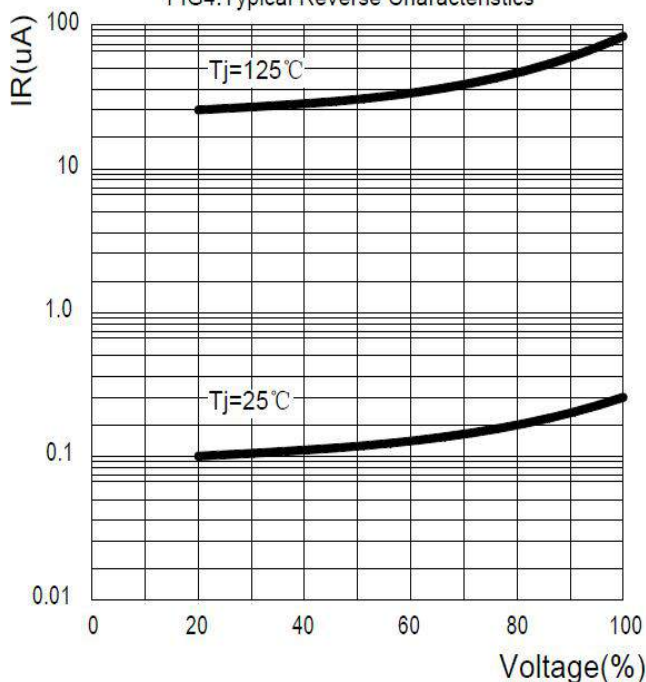
THREE PHASE GLASS PASSIVATED BRIDGE RECTIFIER

REVERSE VOLTAGE 400 to 1600 Volts FORWARD CURRENT 35 Ampere

FEATURES

- ◆ I_o 35A
- ◆ V_{RRM} 400V~1600V
- ◆ Glass passivated chip
- ◆ High surge forward current capability

SKBPC

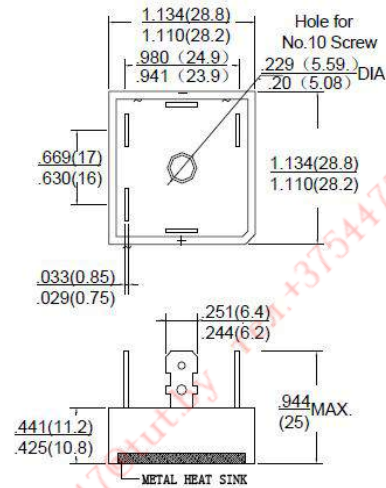

Dimensions in inches and (millimeters)

MAXIMUM RATINGS AND ELECTRICAL CHARACTERISTICS

Rating at 25°C ambient temperature unless otherwise specified.

Single phase, half wave, 60Hz, resistive or inductive load. For capacitive load, derate current by 20%

PARAMETER	SYMBOL	Conditions	SKBC 3504	SKBPC 3506	SKBPC 3508	SKBPC 3510	SKBPC 3512	SKBPC 3514	SKBPC 3516	UNIT
Repetitive Peak Reverse Voltage	V _{RRM}		400	600	800	1000	1200	1400	1600	V
Average Rectified Output Current	I _O	60Hz sine wave, R-load With heatsink T _c =55°C	35							A
Surge(Nonrepetitive) Forward Current	I _{FSM}	60Hz sine wave, 1 cycle, T _a =25°C	425							A
Current Squared Time	I ² t	1ms≤t<8.3ms T _j =25°C Rating of per diode	750							A ² S
Storage Temperature	T _{STG}		-40~+150							°C
Junction Temperature	T _J		-55~+150							°C
Dielectric Strength	V _{dis}	Terminals to case, AC 1 minute	2.5							KV
Item	SYMBOL	UNIT	Test Condition							Max
Peak Forward Voltage	V _{FM}	V	I _{FM} =12A, Pulse measurement, Rating of per							1.2
Peak Reverse Current	I _{RRM}	μA	V _{RM} =V _{RRM} , Pulse measurement, Rating of per diode							10
Thermal Resistance	R _{θJ-C}	°C/W	Between junction and case, With heatsink							1.35

SKBPC3504 THRU SKBPC3516

General purpose 3 phase Bridge Rectifier

REVERSE VOLTAGE 400 to 1600 Volts FORWARD CURRENT 15 Ampere

RATING AND CHARACTERISTIC CURVES SKBPC3504 THRU SKBPC3516

图1: I_o - T_c 曲线
FIG1: I_o - T_c Curve



图2: 耐正向浪涌电流曲线
FIG2: Surge Forward Current Capacity



图3: 正向电压曲线
FIG3: Instantaneous Forward Voltage

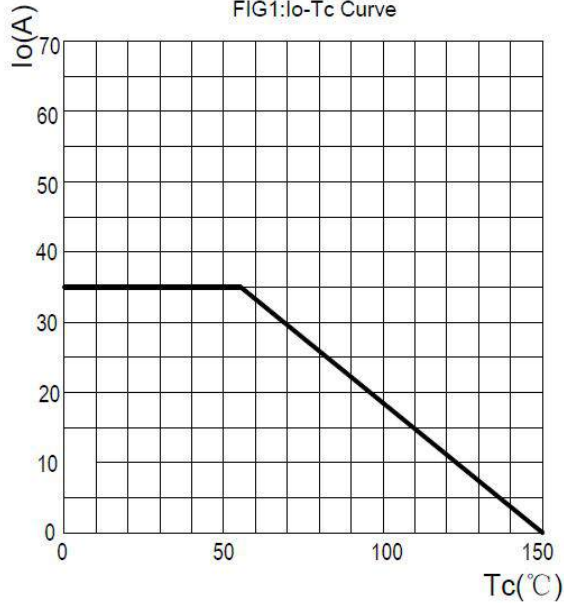

图4: 反向电流曲线
FIG4: Typical Reverse Characteristics

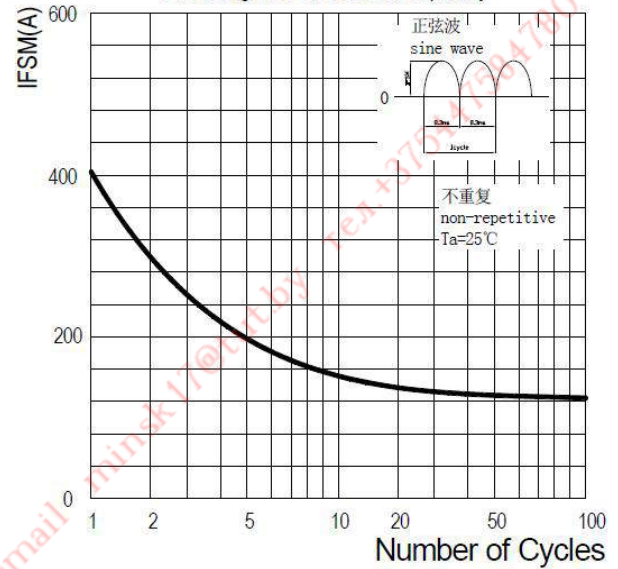

Note: Specifications are subject to change without notice. For more detail and update, please visit our website.

SKBPC5004 THRU SKBPC5016

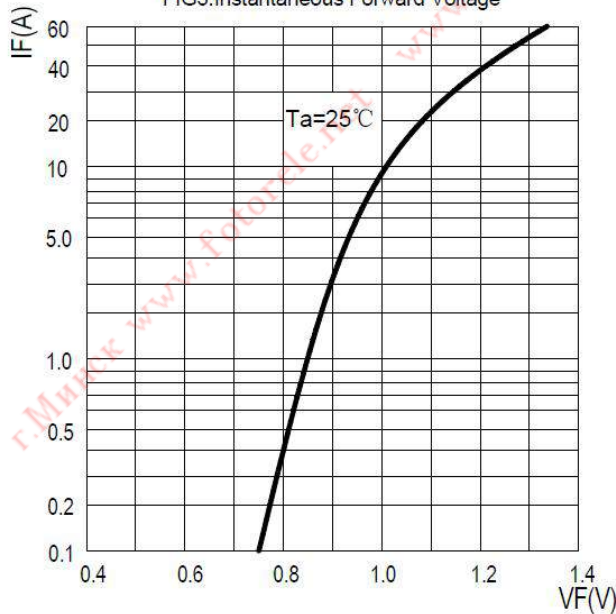
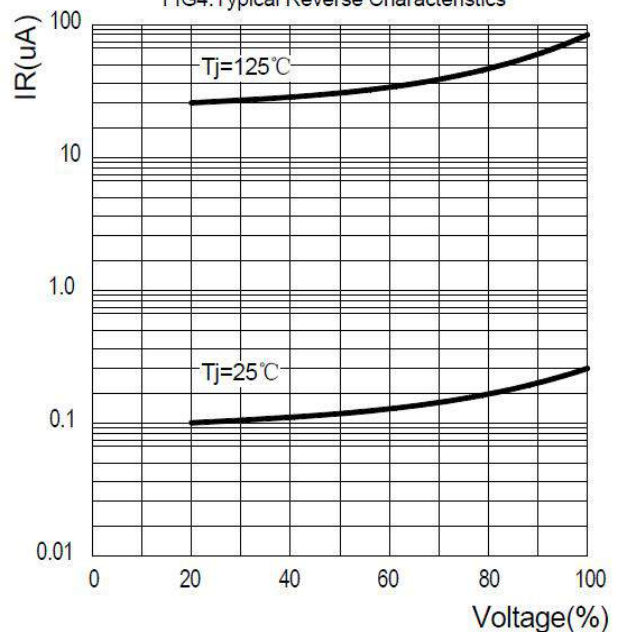
THREE PHASE GLASS PASSIVATED BRIDGE RECTIFIER

REVERSE VOLTAGE 400 to 1600 Volts FORWARD CURRENT 50 Ampere

FEATURES

- ◆ I_o 50A
- ◆ V_{RRM} 400V~1600V
- ◆ Glass passivated chip
- ◆ High surge forward current capability

SKBPC

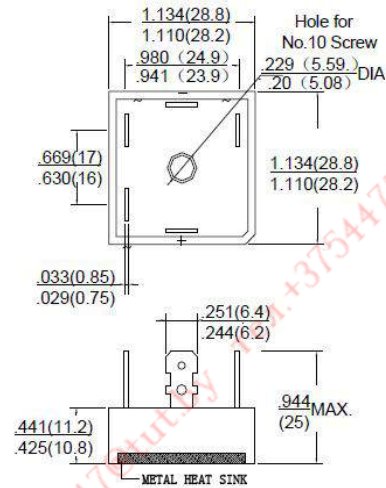

Dimensions in inches and (millimeters)

MAXIMUM RATINGS AND ELECTRICAL CHARACTERISTICS

Rating at 25°C ambient temperature unless otherwise specified.

Single phase, half wave, 60Hz, resistive or inductive load. For capacitive load, derate current by 20%

PARAMETER	SYMBOL	Conditions	SKBC 5004	SKBPC 5006	SKBPC 5008	SKBPC 5010	SKBPC 5012	SKBPC 5014	SKBPC 5016	UNIT
Repetitive Peak Reverse Voltage	V _{RRM}		400	600	800	1000	1200	1400	1600	V
Average Rectified Output Current	I _O	60Hz sine wave, R-load With heatsink T _c =55°C	50							A
Surge(Nonrepetitive) Forward Current	I _{FSM}	60Hz sine wave, 1 cycle, T _a =25°C	500							A
Current Squared Time	I ² t	1ms≤t<8.3ms T _j =25°C Rating of per diode	1040							A ² S
Storage Temperature	T _{STG}		-40~+150							°C
Junction Temperature	T _J		-55~+150							°C
Dielectric Strength	V _{dis}	Terminals to case, AC 1 minute	2.5							KV
Item	SYMBOL	UNIT	Test Condition							Max
Peak Forward Voltage	V _{FM}	V	I _{FM} =17A, Pulse measurement, Rating of per							1.2
Peak Reverse Current	I _{RRM}	μA	V _{RM} =V _{RRM} , Pulse measurement, Rating of per diode							10
Thermal Resistance	R _{θJ-C}	°C/W	Between junction and case, With heatsink							0.9

SKBPC5004 THRU SKBPC5016

General purpose 3 phase Bridge Rectifier

REVERSE VOLTAGE 400 to 1600 Volts FORWARD CURRENT 50 Ampere

RATING AND CHARACTERISTIC CURVES SKBPC5004 THRU SKBPC5016

图1: I_o - T_c 曲线
FIG1: I_o - T_c Curve



图2: 耐正向浪涌电流曲线
FIG2: Surge Forward Current Capability



图3: 正向电压曲线
FIG3: Instantaneous Forward Voltage

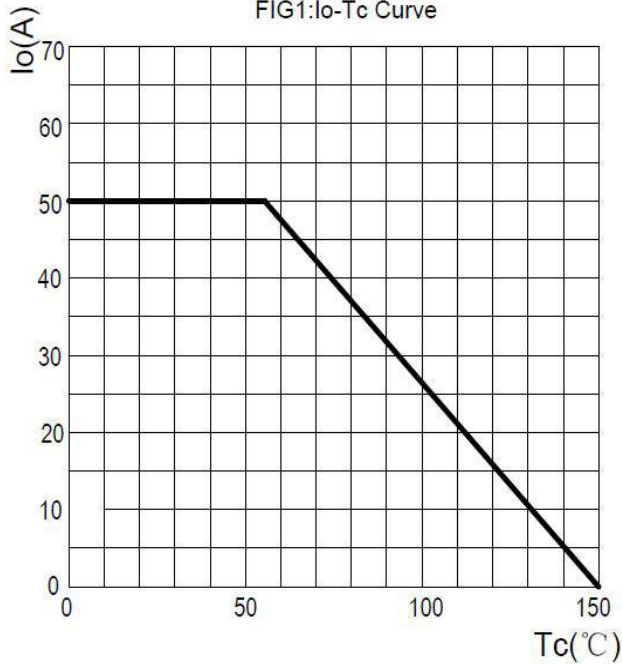

图4: 反向电流曲线
FIG4: Typical Reverse Characteristics

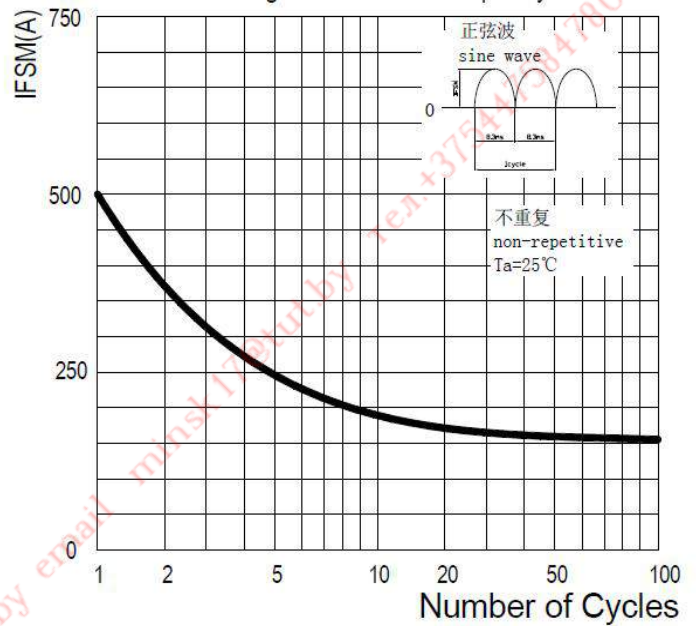

Note: Specifications are subject to change without notice. For more detail and update, please visit our website.

S25VB005 THRU S25VB100

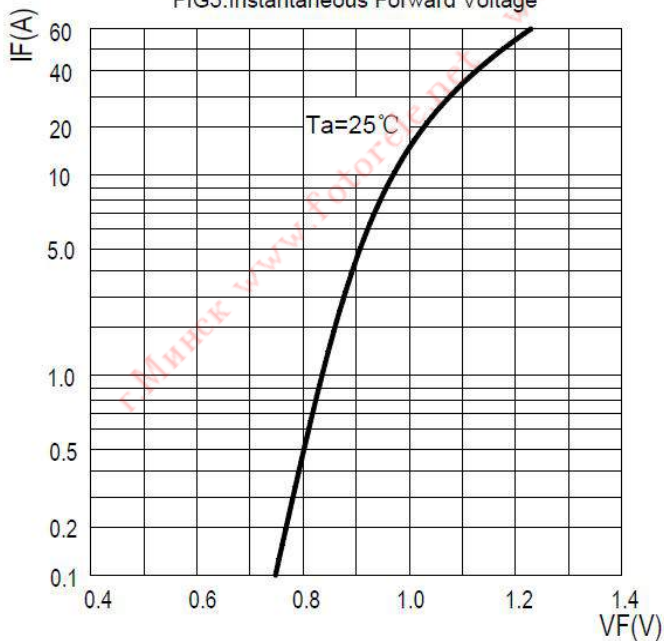
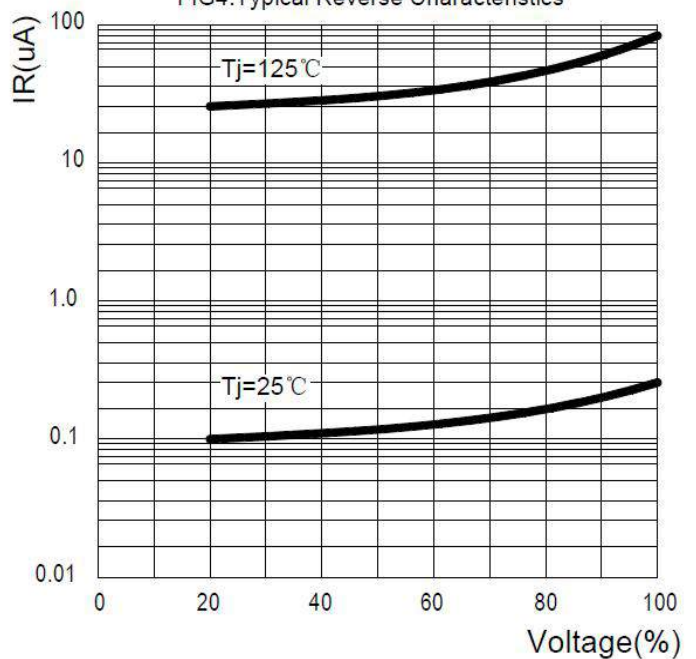
SINGLE-PHASE BRIDGE RECTIFIER GLASS PASSIVATED BRIDGE RECTIFIERS
 REVERSE VOLTAGE 50 to 1000 Volts FORWARD CURRENT 25 Ampere

FEATURES

- ◆ Rating to 1000V PRV
- ◆ High efficiency
- ◆ Glass passivated chip junction
- ◆ Electrically isolated metal case for maximum heat Dissipation
- ◆ The plastic material has UL flammability classification 94V-0
- ◆ Electrically isolated base-2500 Volts

Mechanical Data

- ◆ Case : Molded plastic with Heatsink internally mounted in the bridge encapsulation
- ◆ Polarity : As marked on Body
- ◆ Mounting : Hole for # 10 screw
- ◆ Weight : 0.70 ounces , 20 grams (terminal)

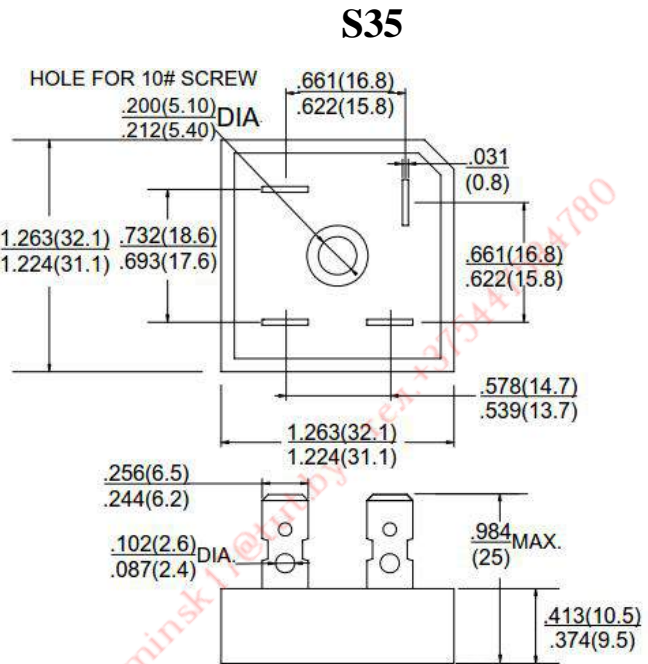

Dimensions in inches and (millimeters)

MAXIMUM RATINGS AND ELECTRICAL CHARACTERISTICS

Rating at 25°C ambient temperature unless otherwise specified.

Single phase, half wave, 60Hz, resistive or inductive load. For capacitive load, derate current by 20%

PARAMETER	SYMBOL	S25VB 005	S25VB 10	S25VB 20	S25VB 40	S25VB 60	S25VB 80	S25VB 100	UNIT
Maximum Recurrent Peak Reverse Voltage	V_{RRM}	50	100	200	400	600	800	1000	v
Maximum RMS Voltage	V_{RRM}	35	70	140	280	420	560	700	v
Maximum DC Blocking Voltage	V_{DC}	50	100	200	400	600	800	1000	v
Maximum Average Forward Rectified Current @ $T_c=T_a$	$I_{(AV)}$	25.0							A
Peak Forward Surge Current 8.3ms Single half sine-wave superimposed on rated load	I_{FSM}	350							A
Maximum Forward Voltage at 12.5A DC	V_F	1.05							v
Maximum DC Reverse Current @ $T_j=25^\circ C$ at rated DC blocking voltage @ $T_j=125^\circ C$	I_R	5.0 500							μA
I^2t Rating for Fusing ($t < 8.3ms$)	I^2t	370							A^2S
Typical Junction Capacitance per element (Note 2)	C_J	150							pF
Typical Thermal Resistance	$R_{\theta JC}$	1.4							$^\circ C/W$
Operating Temperature Range	T_J	-55 to +150							$^\circ C$
Storage Temperature Range	T_{STG}	-55 to +150							$^\circ C$

Note: 1. Measured at non-repetitive, for greater than 1ms and less than 8.3ms

2. Measured at 1.0MHz and applied reverse voltage of 4.0V DC.

S25VB005 THRU S25VB100

SINGLE-PHASE BRIDGE RECTIFIER GLASS PASSIVATED BRIDGE RECTIFIERS
 REVERSE VOLTAGE 50 to 1000 Volts FORWARD CURRENT 25 Ampere

RATING AND CHARACTERISTIC CURVES S25VB005 THRU S25VB100

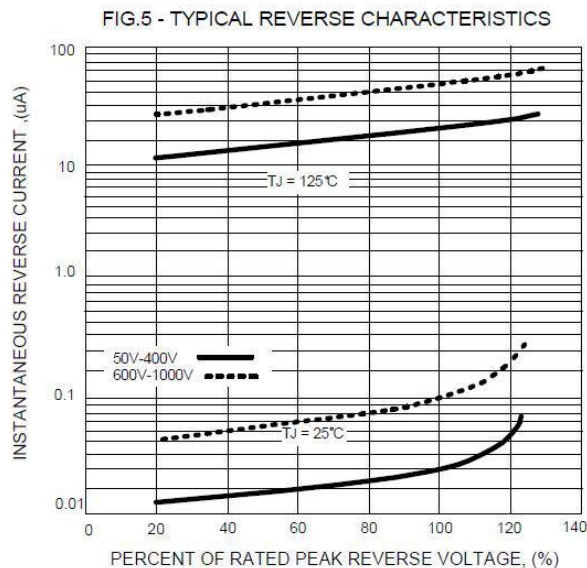
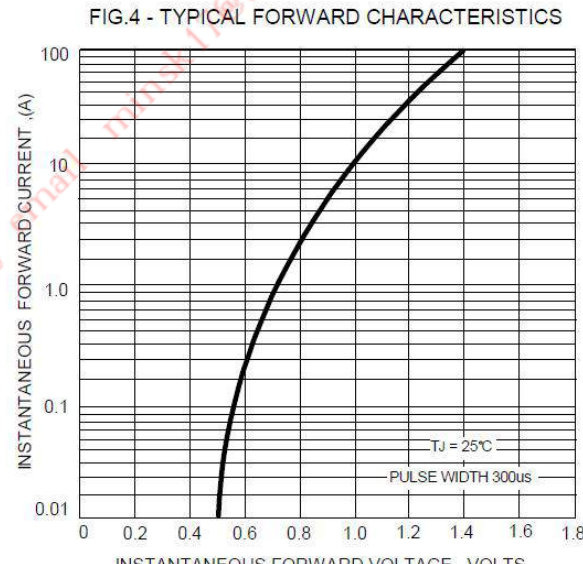
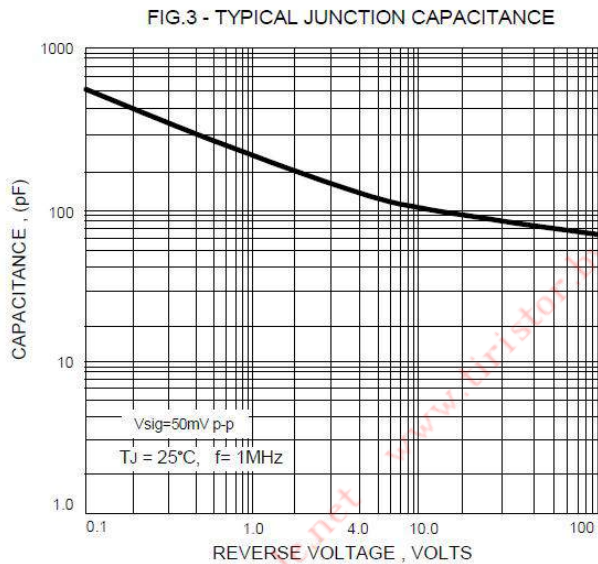
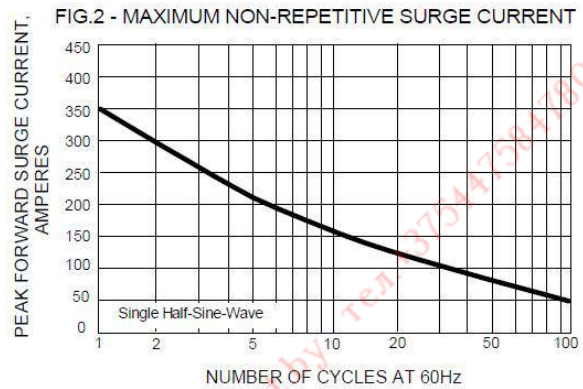
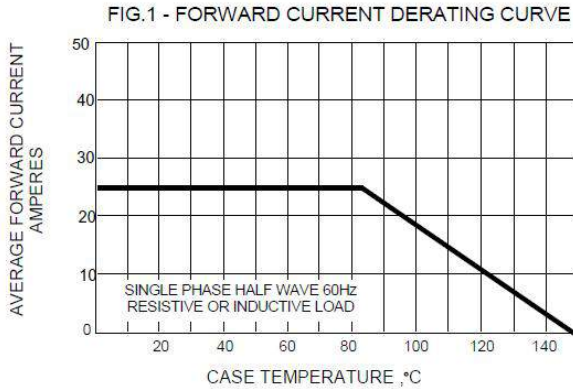

Note: Specifications are subject to change without notice. For more detail and update, please visit our website.

S35VB005 THRU S35VB100

SINGLE-PHASE BRIDGE RECTIFIER GLASS PASSIVATED BRIDGE RECTIFIERS
 REVERSE VOLTAGE 50 to 1000 Volts FORWARD CURRENT 35 Ampere

FEATURES

- ◆ Rating to 1000V PRV
- ◆ High efficiency
- ◆ Glass passivated chip junction
- ◆ Electrically isolated metal case for maximum heat Dissipation
- ◆ The plastic material has UL flammability classification 94V-0
- ◆ Electrically isolated base-2500 Volts

Mechanical Data

- ◆ Case : Molded plastic with Heatsink internally mounted in the bridge encapsulation
- ◆ Polarity : As marked on Body
- ◆ Mounting : Hole for # 10 screw
- ◆ Weight : 0.70 ounces , 20 grams (terminal)

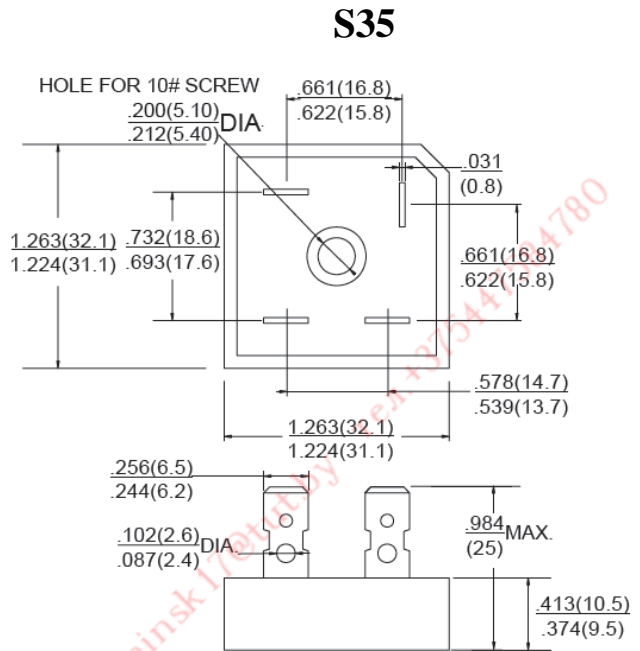

Dimensions in inches and (millimeters)

MAXIMUM RATINGS AND ELECTRICAL CHARACTERISTICS

Rating at 25°C ambient temperature unless otherwise specified.

Single phase, half wave, 60Hz, resistive or inductive load. For capacitive load, derate current by 20%

PARAMETER	SYMBOL	S35VB 005	S35VB 10	S35VB 20	S35VB 40	S35VB 60	S35VB 80	S35VB 100	UNIT
Maximum Recurrent Peak Reverse Voltage	V_{RRM}	50	100	200	400	600	800	1000	v
Maximum RMS Voltage	V_{RRM}	35	70	140	280	420	560	700	v
Maximum DC Blocking Voltage	V_{DC}	50	100	200	400	600	800	1000	v
Maximum Average Forward Rectified Current @ $T_c=T_a$	$I_{(AV)}$	35.0							A
Peak Forward Surge Current 8.3ms Single half sine-wave superimposed on rated load	I_{FSM}	400							A
Maximum Forward Voltage at 17.5A DC	V_F	1.05							v
Maximum DC Reverse Current @ $T_j=25^\circ C$ at rated DC blocking voltage @ $T_j=125^\circ C$	I_R	5.0 500							μA
I^2t Rating for Fusing ($t < 8.3ms$), (Note 1)	I^2t	660							A^2S
Typical Junction Capacitance per element (Note 2)	C_j	150							pF
Typical Thermal Resistance	$R_{\theta JC}$	1.4							$^\circ C/W$
Operating Temperature Range	T_j	-55 to +150							$^\circ C$
Storage Temperature Range	T_{STG}	-55 to +150							$^\circ C$

Note: 1. Measured at non-repetitive, for greater than 1ms and less than 8.3ms

2. Measured at 1.0MHz and applied reverse voltage of 4.0V DC.

S35VB005 THRU S35VB100

SINGLE-PHASE BRIDGE RECTIFIER GLASS PASSIVATED BRIDGE RECTIFIERS
 REVERSE VOLTAGE 50 to 1000 Volts FORWARD CURRENT 35 Ampere

RATING AND CHARACTERISTIC CURVES S35VB005 THRU S35VB100

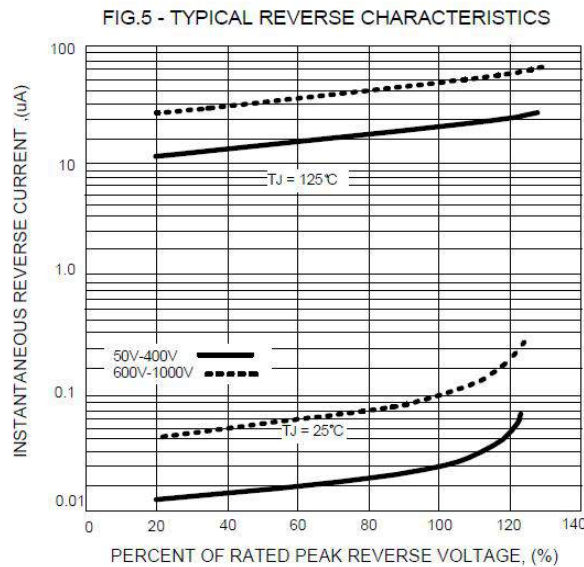
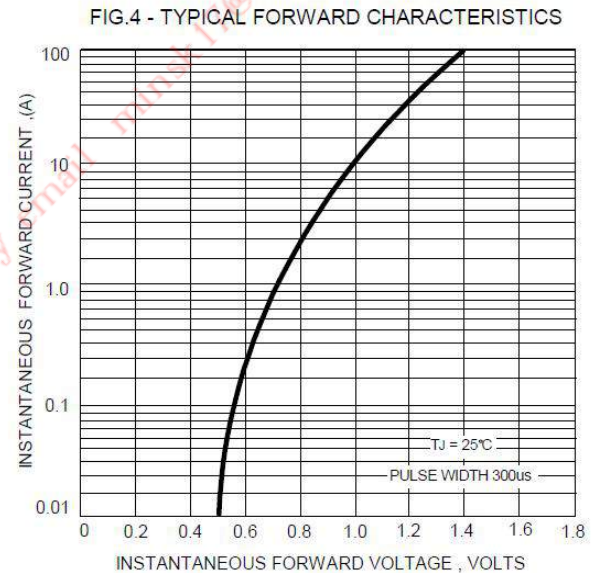
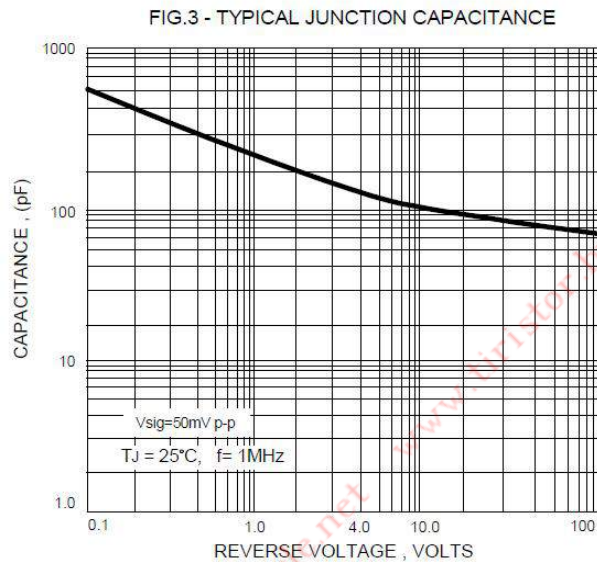
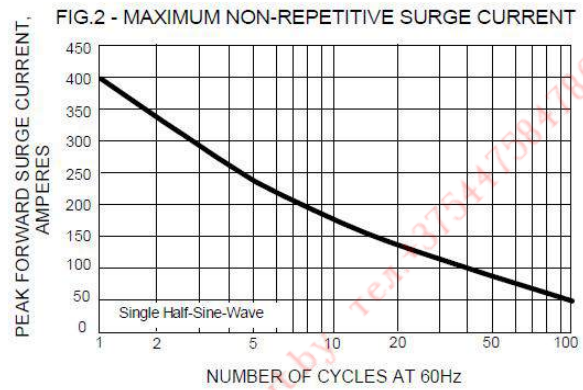
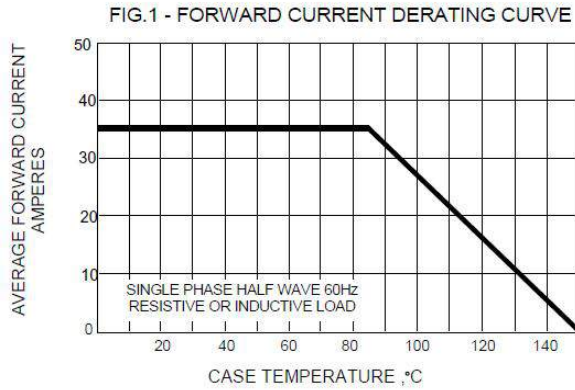

Note: Specifications are subject to change without notice. For more detail and update, please visit our website.

S50VB005 THRU S50VB100

SINGLE-PHASE BRIDGE RECTIFIER GLASS PASSIVATED BRIDGE RECTIFIERS
 REVERSE VOLTAGE 50 to 1000 Volts FORWARD CURRENT 50 Ampere

FEATURES

- ◆ Rating to 1000V PRV
- ◆ High efficiency
- ◆ Glass passivated chip junction
- ◆ Electrically isolated metal case for maximum heat Dissipation
- ◆ The plastic material has UL flammability classification 94V-0
- ◆ Electrically isolated base-2500 Volts

Mechanical Data

- ◆ Case : Molded plastic with Heatsink internally mounted in the bridge encapsulation
- ◆ Polarity : As marked on Body
- ◆ Mounting : Hole for # 10 screw
- ◆ Weight : 0.70 ounces , 20 grams (terminal)

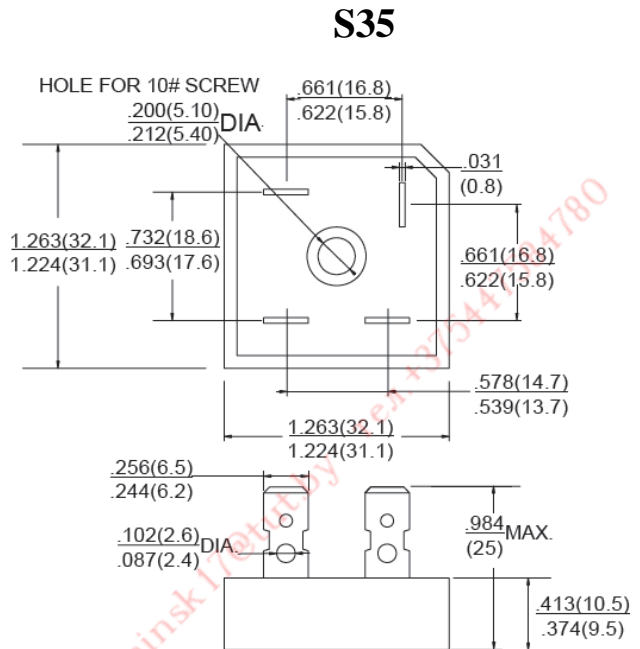

Dimensions in inches and (millimeters)

MAXIMUM RATINGS AND ELECTRICAL CHARACTERISTICS

Rating at 25°C ambient temperature unless otherwise specified.

Single phase, half wave, 60Hz, resistive or inductive load. For capacitive load, derate current by 20%

PARAMETER	SYMBOL	S50VB 005	S50VB 10	S50VB 20	S50VB 40	S50VB 60	S50VB 80	S50VB 100	UNIT
Maximum Recurrent Peak Reverse Voltage	V_{RRM}	50	100	200	400	600	800	1000	v
Maximum RMS Voltage	V_{RRM}	35	70	140	280	420	560	700	v
Maximum DC Blocking Voltage	V_{DC}	50	100	200	400	600	800	1000	v
Maximum Average Forward Rectified Current @ $T_c=T_a$	$I_{(AV)}$	50.0							A
Peak Forward Surge Current 8.3ms Single half sine-wave superimposed on rated load	I_{FSM}	450							A
Maximum Forward Voltage at 25.0A DC	V_F	1.1							v
Maximum DC Reverse Current @ $T_j=25^\circ C$ at rated DC blocking voltage @ $T_j=125^\circ C$	I_R	5.0 500							μA
I^2t Rating for Fusing($t<8.3ms$), (Note 1)	I^2t	800							A^2S
Typical Junction Capacitance per element (Note 2)	C_J	150							pF
Typical Thermal Resistance	$R_{\theta JC}$	1.4							$^\circ C/W$
Operating Temperature Range	T_J	-55 to +150							$^\circ C$
Storage Temperature Range	T_{STG}	-55 to +150							$^\circ C$

Note: 1. Measured at non-repetitive, for greater than 1ms and less than 8.3ms

2. Measured at 1.0MHz and applied reverse voltage of 4.0V DC.

S50VB005 THRU S50VB100

SINGLE-PHASE BRIDGE RECTIFIER GLASS PASSIVATED BRIDGE RECTIFIERS
 REVERSE VOLTAGE 50 to 1000 Volts FORWARD CURRENT 50 Ampere

RATING AND CHARACTERISTIC CURVES S50VB005 THRU S50VB100

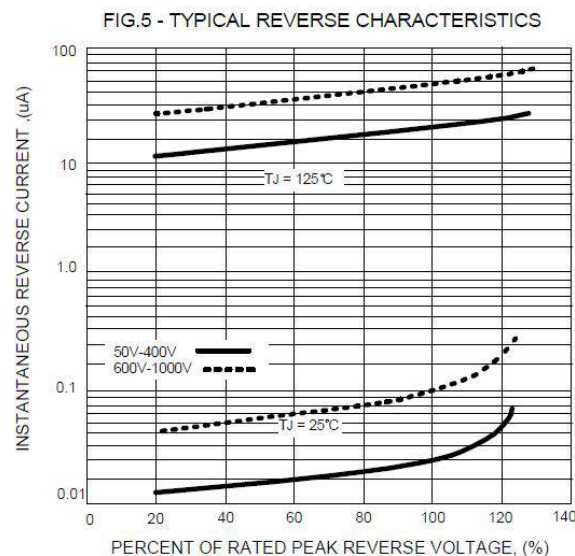
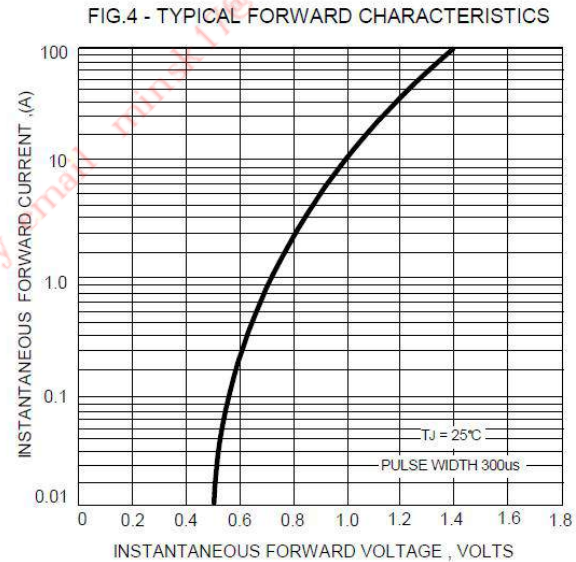
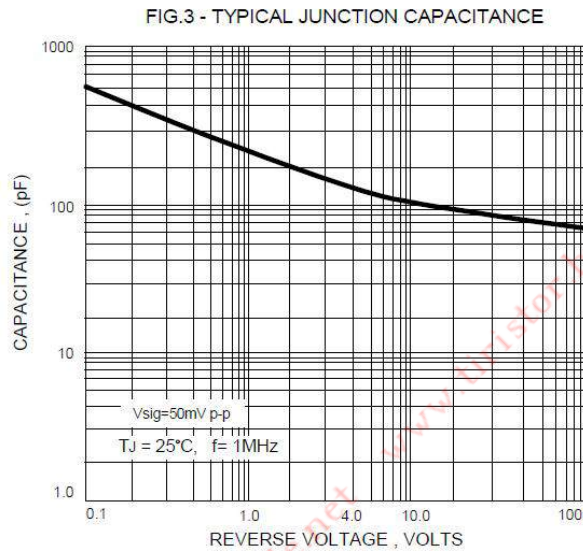
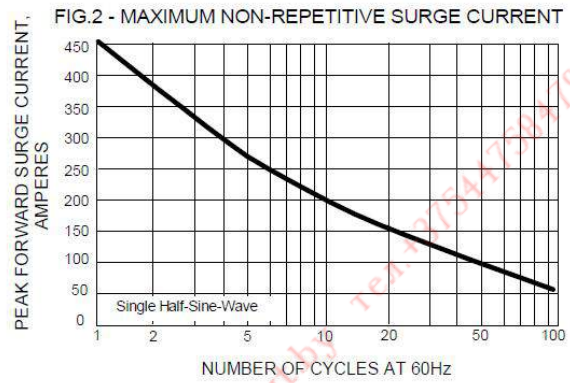
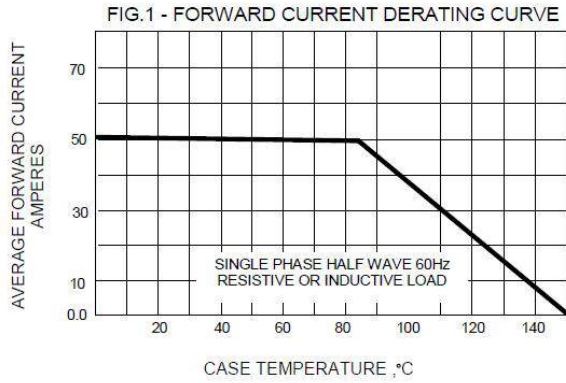

Note: Specifications are subject to change without notice. For more detail and update, please visit our website.

каталог, описание, технические, характеристики, datasheet, однофазный, трёхфазный,
параметры, маркировка, габариты, фото, skbpc, skbpc5010, даташит, аналог, замена

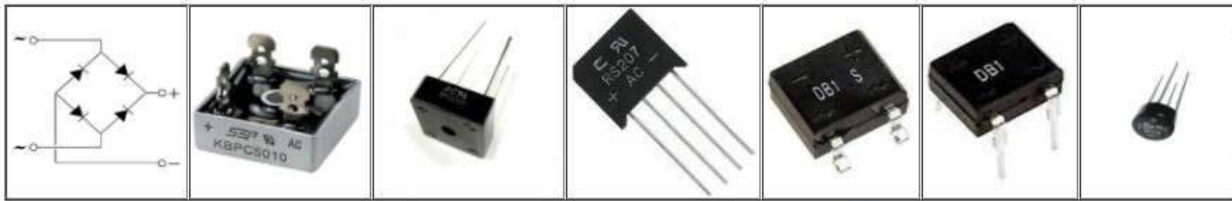

Диодные мосты
однофазные KBPC



Диодные мосты
однофазные QL



Диодные мосты
трёхфазные SQL



Диодные мосты
однофазные MDQ



Диодные мосты
трёхфазные MDS



Диодные мосты
однофазные DF10M

Минск www.fotorele.net www.tiristor.by
email minsk17@tut.by тел.+375447584780
и другие, радиодетали, электронные компоненты
каталог, описание, технические, характеристики,
datasheet,
параметры, маркировка, габариты, фото, аналог,
замена
смотрите ниже

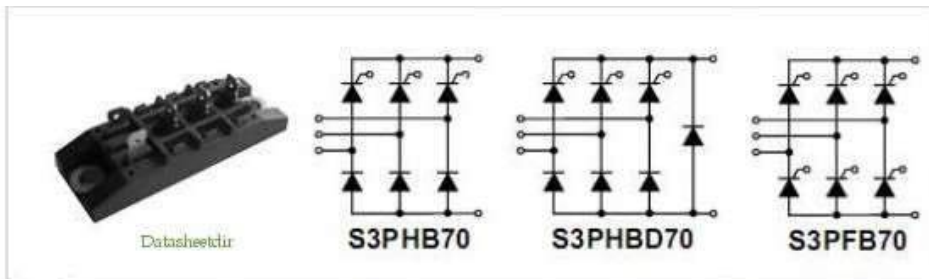

Трёхфазные полностью управляемые мосты

Трёхфазные полууправляемые мосты

Трёхфазные полууправляемые мосты с разрядным

Трёхфазные тиристорные модули с общим анодом

Однофазные выпрямительные мосты

Трёхфазные выпрямительные мосты